

AMENDED



Home of the Tualatin River National Wildlife Refuge

6:00PM URA BOARD WORK SESSION

1. Community Center Update

REGULAR CITY COUNCIL MEETING

1. CALL TO ORDER
2. PLEDGE OF ALLEGIANCE
3. ROLL CALL
4. CONSENT
 - A. Approval of September 3, 2013 Council Meeting Minutes
5. PRESENTATIONS
 - A. Eagle Scout Recognition
6. PUBLIC HEARING
 - A. Ordinance 2013-007 an ordinance approving the Sherwood Town Center Plan and amending the Comprehensive Plan Text to reflect the Town Center Plan and establish a vision, policy and strategies to guide future implementation
(Julia Hajduk, Community Development Director)
7. CITIZEN COMMENTS
8. COUNCIL ANNOUNCEMENTS
9. CITY MANAGER AND DEPARTMENT REPORTS
10. ADJOURN to Executive Session

How to Find Out What's on the Council Schedule:

City Council meeting materials and agenda are posted to the City web page at www.sherwoodoregon.gov, by the Friday prior to a Council meeting. Council agendas are also posted at the Sherwood Library/City Hall, the YMCA, the Senior Center, and the City's bulletin board at Albertson's. Council meeting materials are available to the public at the Library.

To Schedule a Presentation before Council:

If you would like to appear before Council, please submit your name, phone number, the subject of your presentation and the date you wish to appear to the City Recorder Sylvia Murphy by calling 503-625-4246 or by e-mail to: murphys@sherwoodoregon.gov

AGENDA SHERWOOD CITY

**COUNCIL
September 17, 2013**

6:00 pm URA Board Work Session

7:00 pm Regular City Council Meeting

City Council Executive Session

Pursuant to ORS 192.660 (2)(i) & (2)(f)
Performance Evaluation &

Exempt Public Records

(following the Regular Council Meeting)

**Sherwood City Hall
22560 SW Pine Street
Sherwood, OR 97140**

Sherwood URA Board Meeting

Date: Sept 17, 2013

List of Meeting Attendees: —

Request to Speak Forms: —

Documents submitted at meeting: ✓

Work Session - Only

A.) Community Center Project Update - Exh. A

Sherwood Community Center

URA Board Work-Session

URBAN RENEWAL AGENCY, CITY OF SHERWOOD / ANKROM MOISAN
17 SEPTEMBER 2013

Sept 17, 2013
Date

URA Board of Directors
Gov. Body

Work Session
Agenda Item

A
Exhibit #



Ankrom Moisan Architects, Inc.
ARCHITECTURE INTERIORS URBAN DESIGN BRANDING
ankrommoisan.com

6720 SW Macadam Ave / Suite 100
Portland, OR 97219
503.245.7100

117 S Main St / Suite 400
Seattle, WA 98104
206.576.1600



SHERWOOD COMMUNITY CENTER / SHERWOOD, OR

Development Plan
Sherwood Cannery Square



Site Plan



Project Site



Vision for the Future
Exterior Perspective



SHERWOOD COMMUNITY CENTER / SHERWOOD, OR

First Floor Plan
Performance Layout

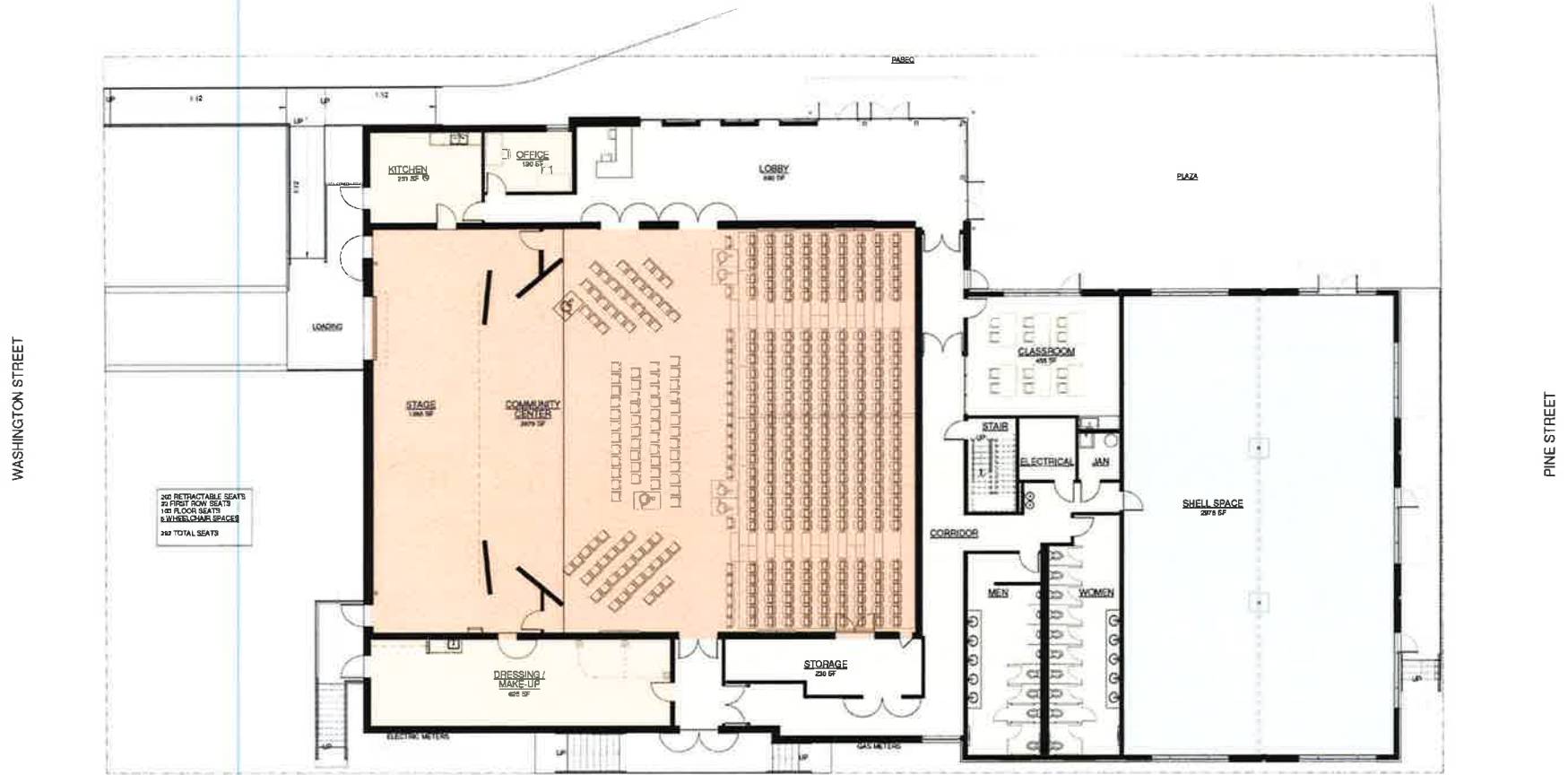

Interior Perspective
Performance Layout

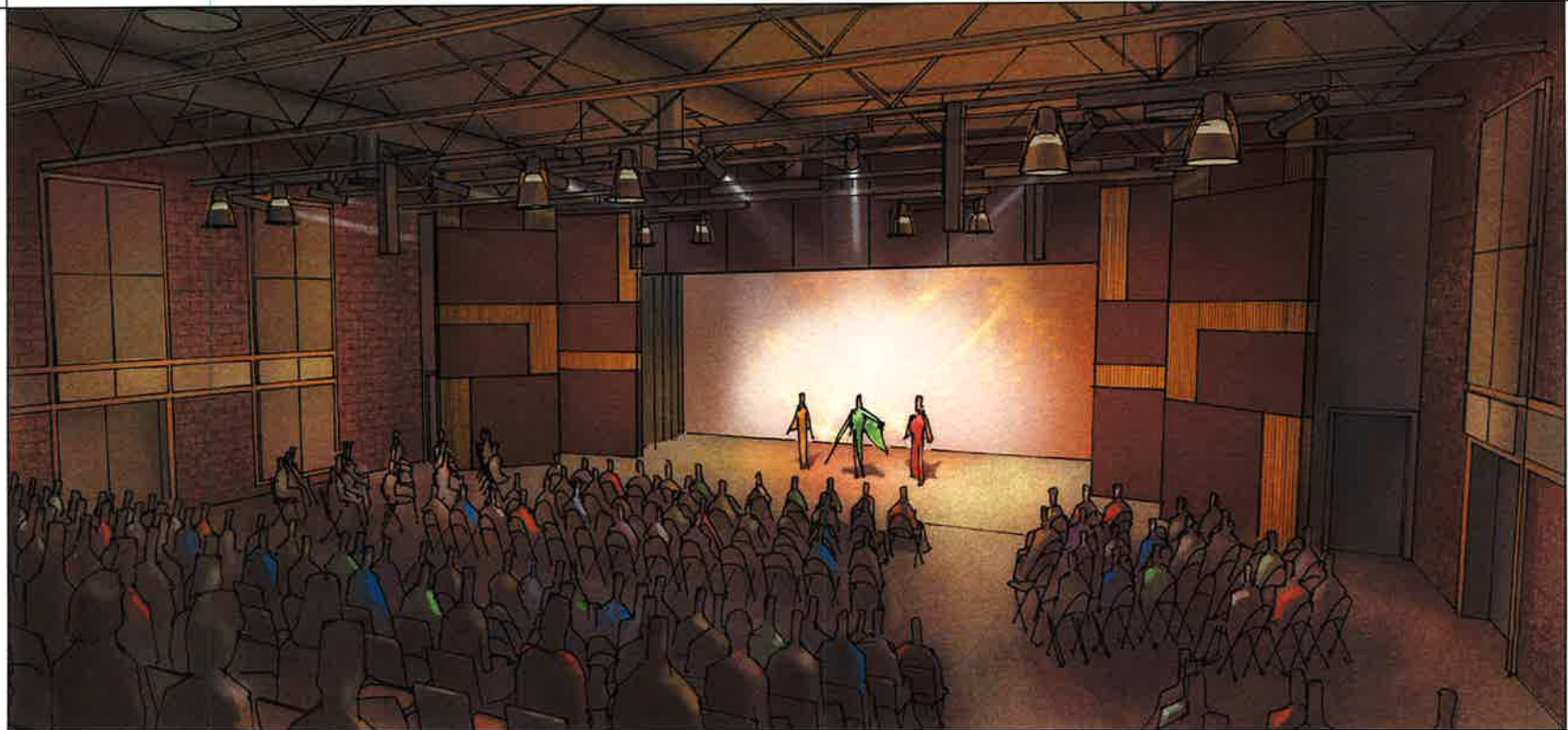

SHERWOOD COMMUNITY CENTER / SHERWOOD, OR

First Floor Plan
Banquet Layout

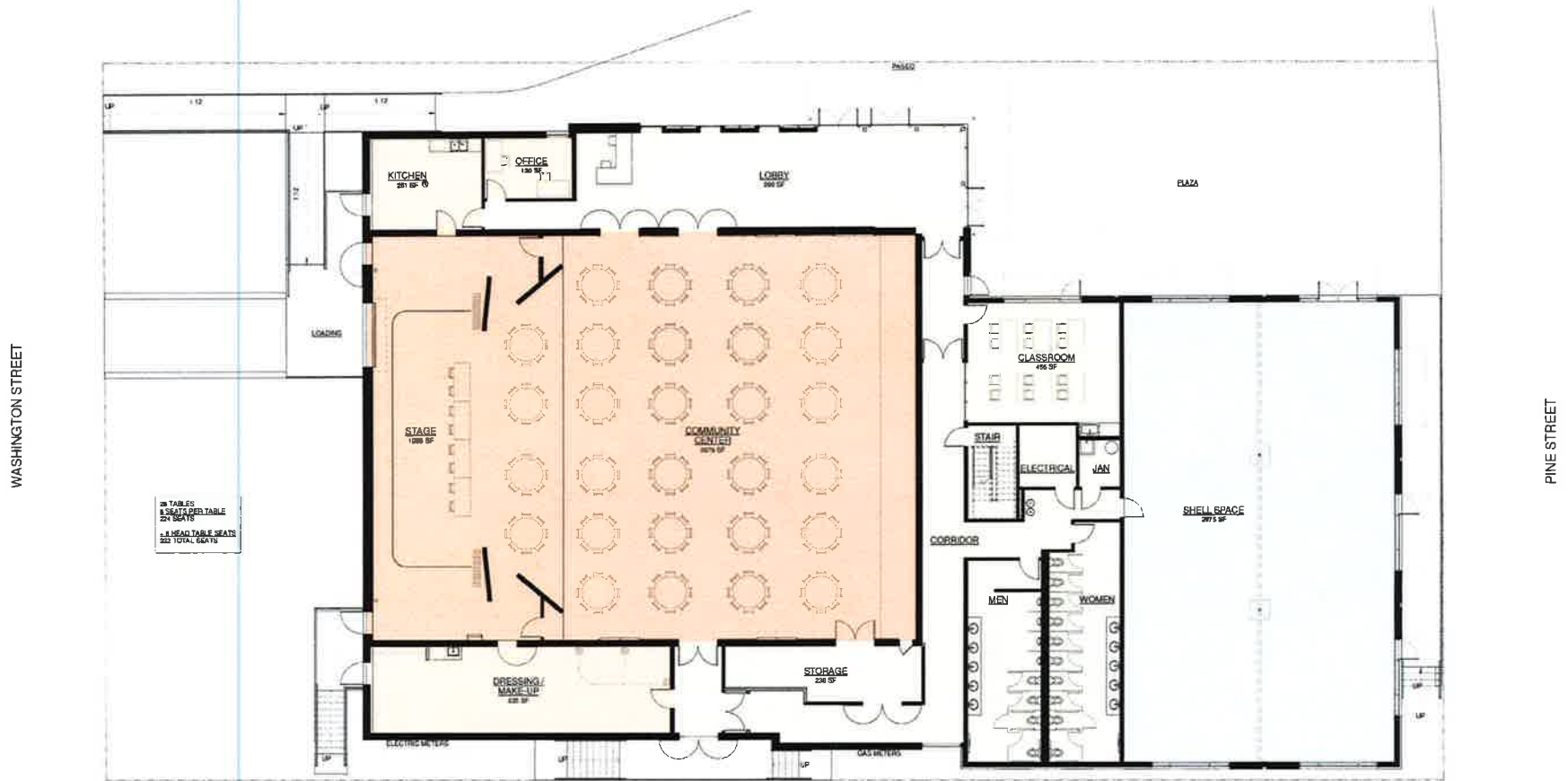

Interior Perspective
Banquet Layout



Second Floor Plan

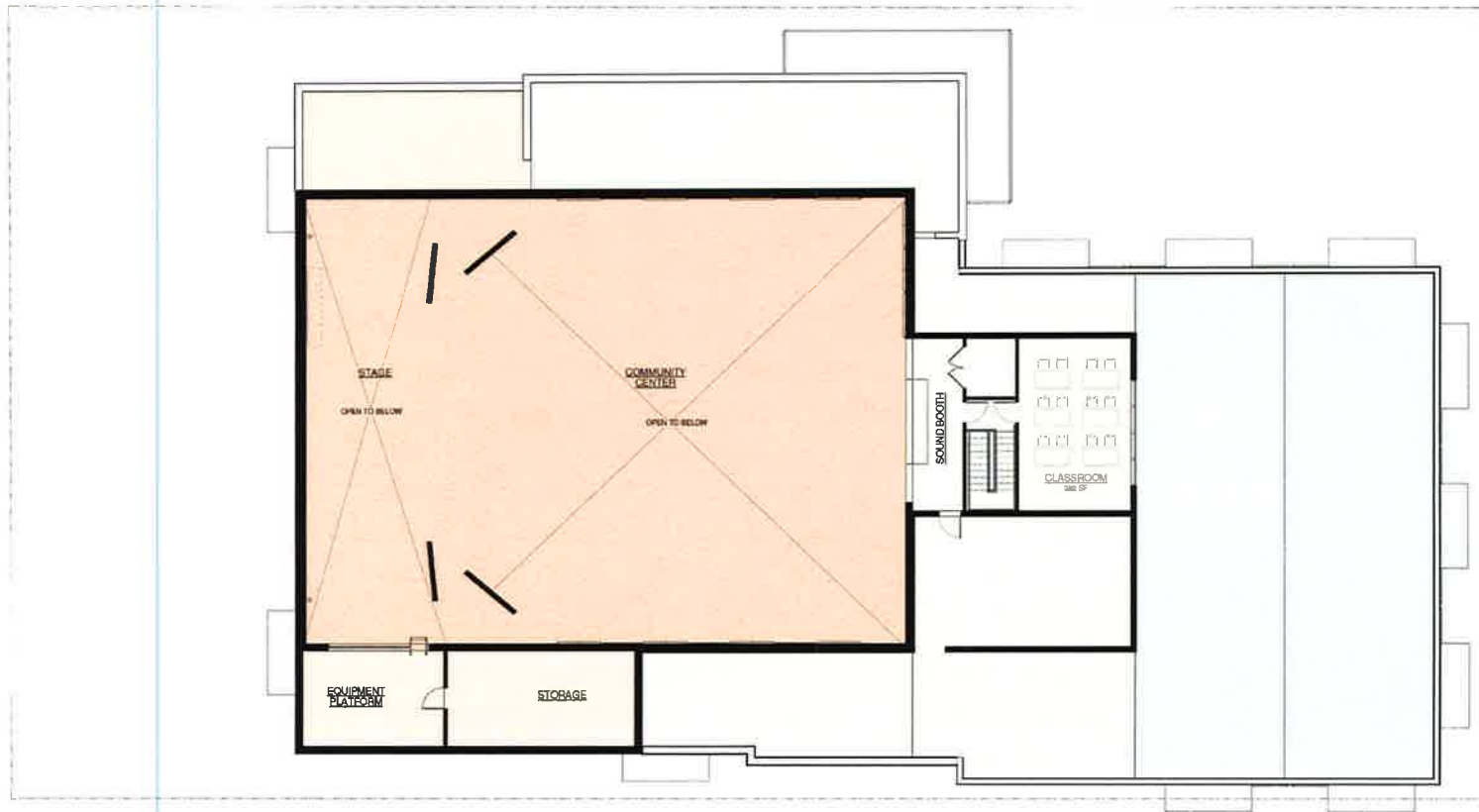

Acoustic Components

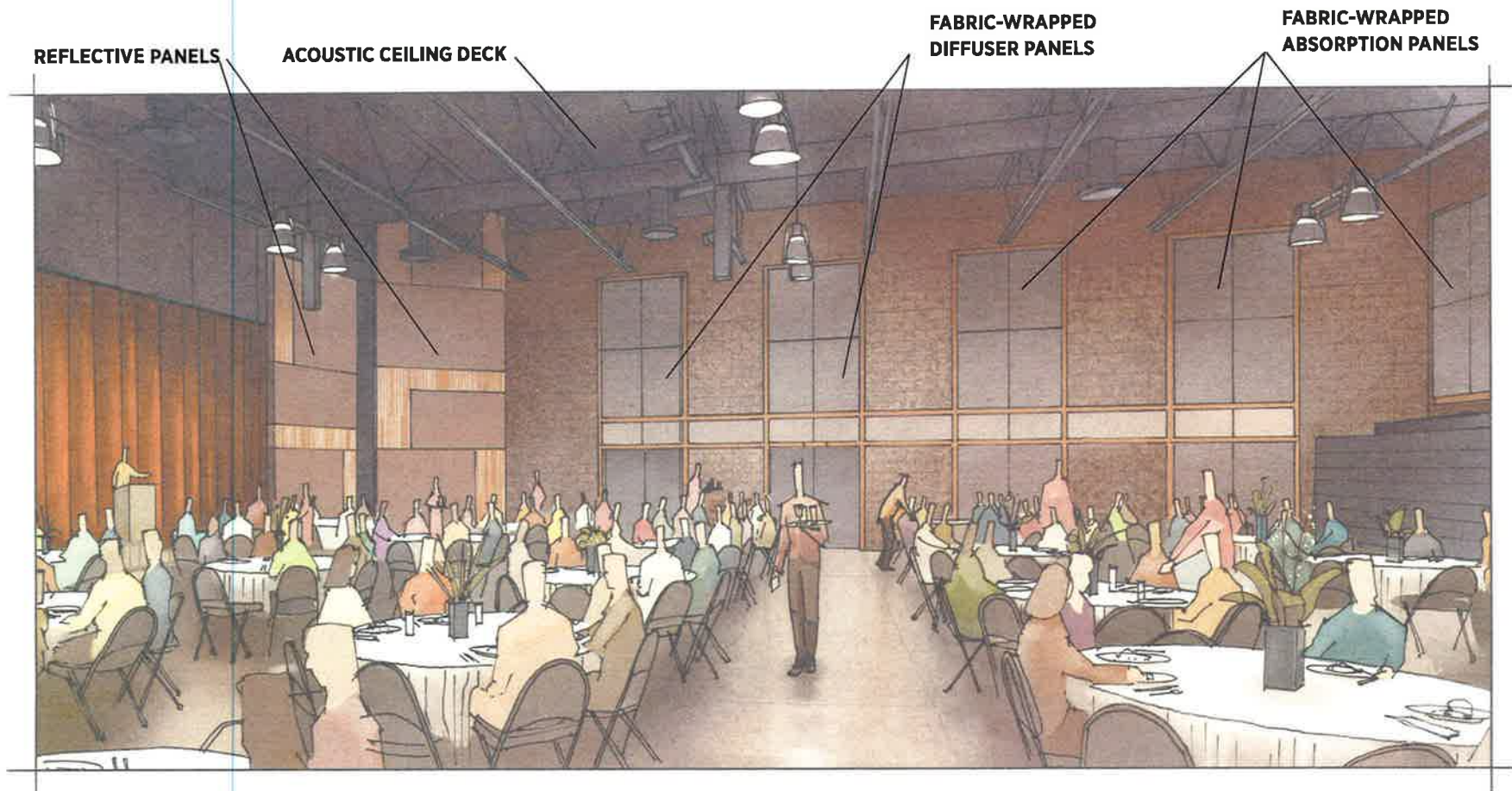

Acoustic Components

VERTICAL SPEAKERS



Audio Visual Systems
First Floor Plan



Audio Visual Systems
Second Floor Plan

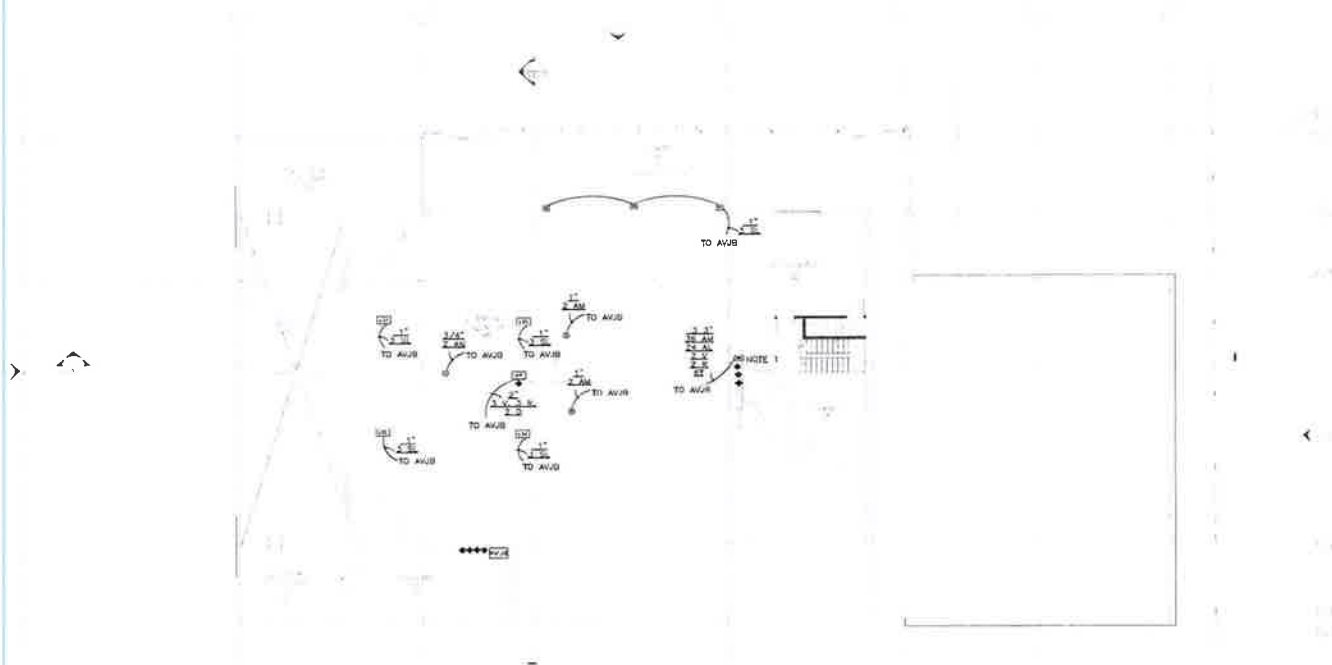

Audio Visual Controls

TOUCH SCREEN



SHERWOOD COMMUNITY CENTER / SHERWOOD, OR

Telescopic Seating System
Plan View

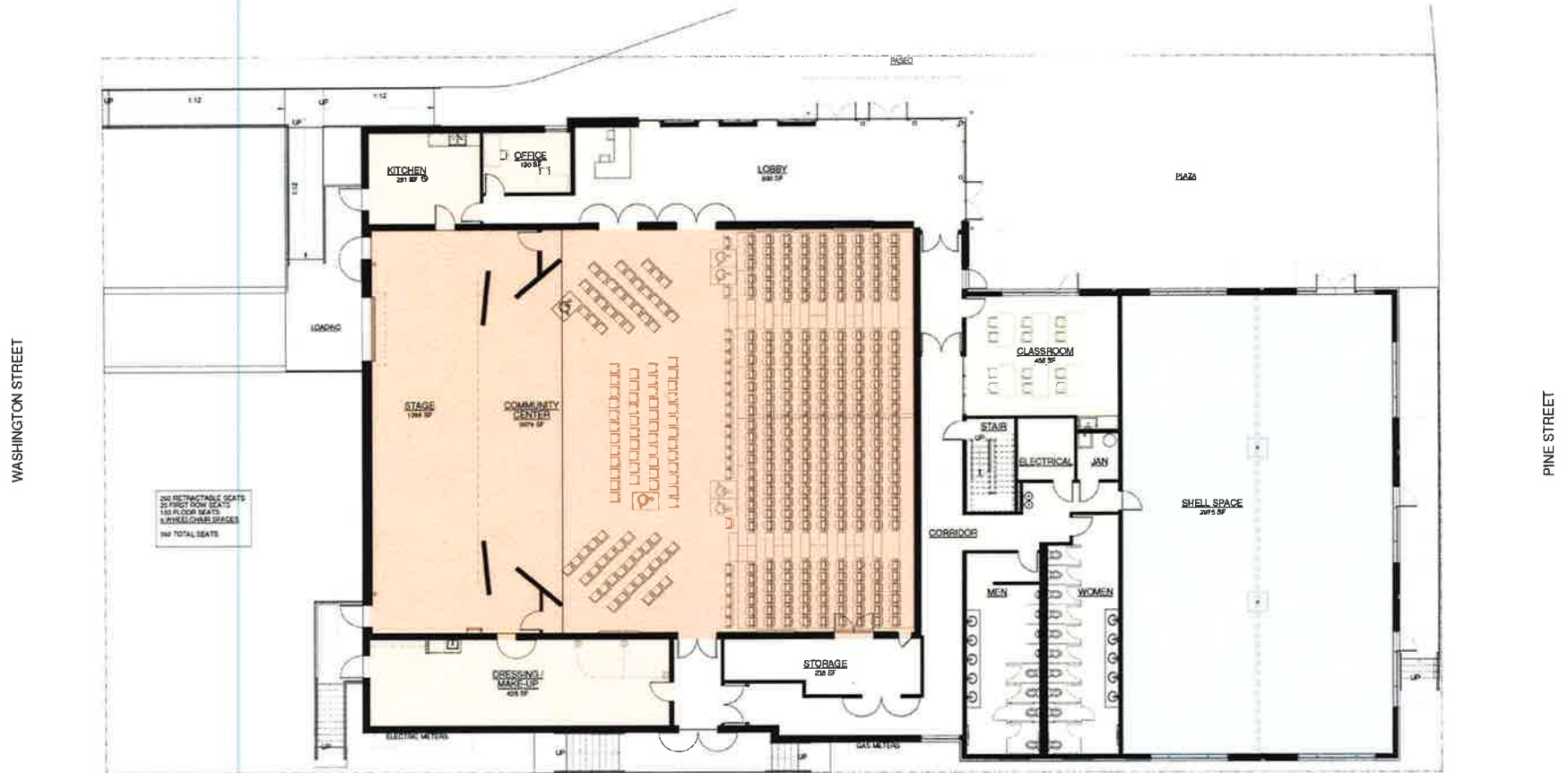

Telescopic Seating System
Section Views

SEATING SYSTEM / EXTENDED

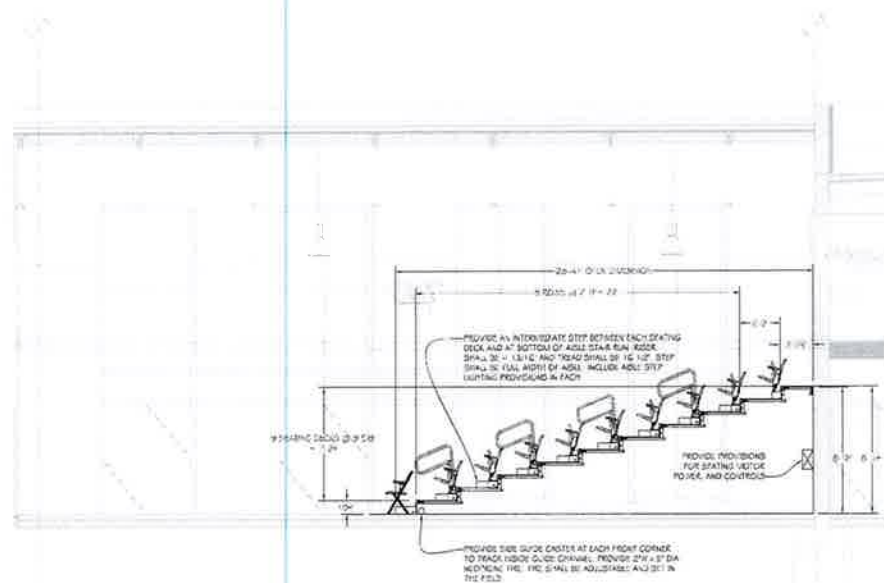

SEATING SYSTEM / RETRACTED

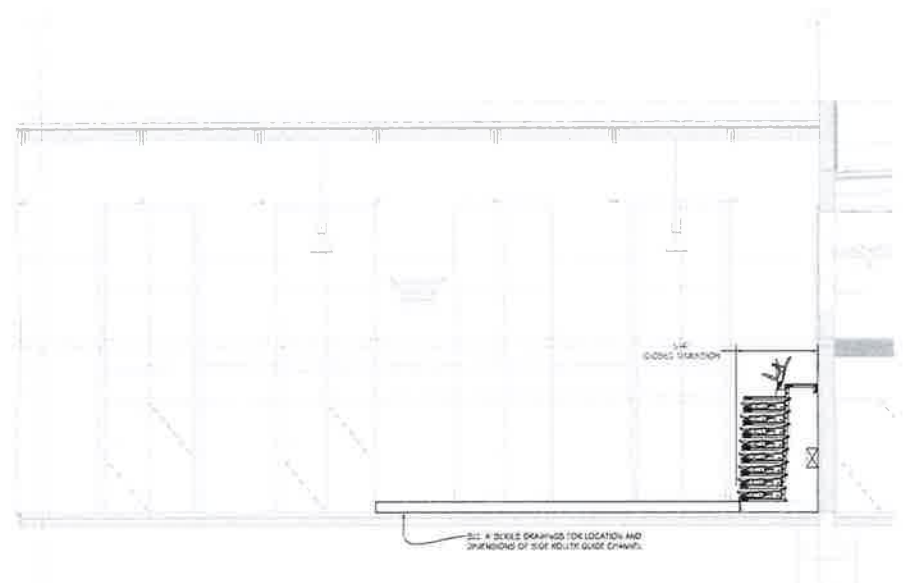

Stage Rigging / Pipe Grid
Perspective and Section View

PIPE GRID EXAMPLE

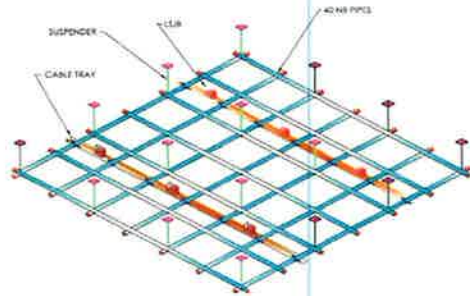

STAGE / MAIN HALL SECTION

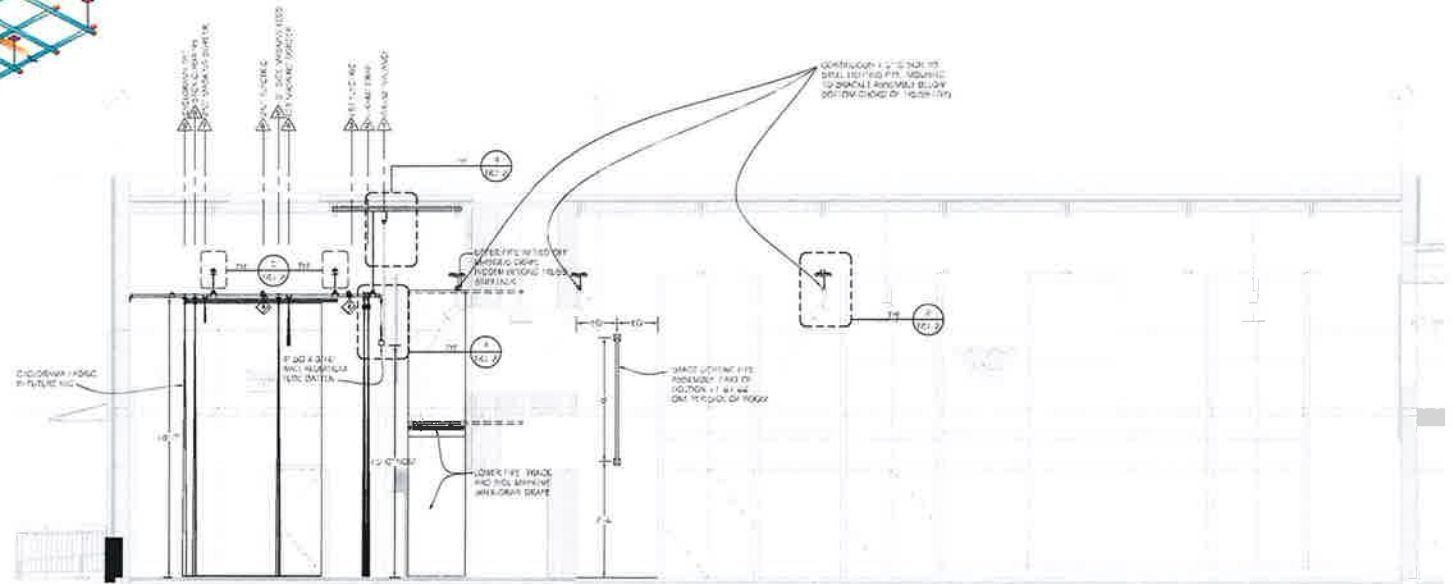

Stage Rigging / Pipe Grid
Plan Views

DRAPE AND TRACK

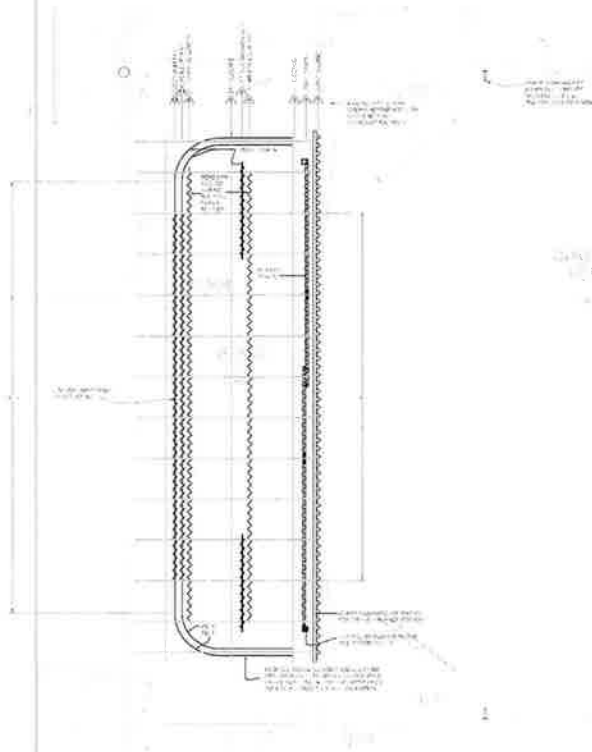

LIGHT PIPE AND PIPE GRID

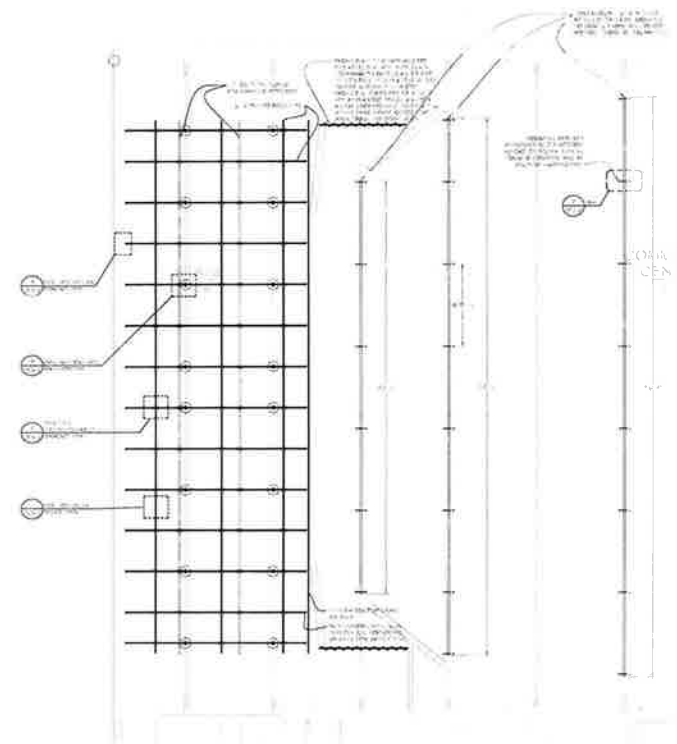

Lighting Controls

TOUCH SCREEN



DIMMER BAR

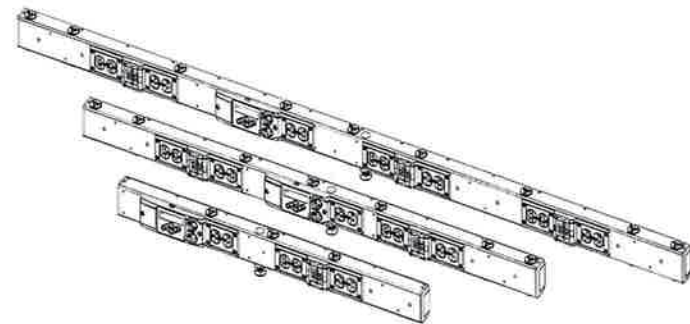

BUTTON STATION



CONTROL CONSOLE





Approved Minutes

**SHERWOOD URBAN RENEWAL AGENCY BOARD OF DIRECTORS
MEETING MINUTES
Tuesday, September 17, 2013
22560 SW Pine Street, Sherwood, Oregon 97140**

URA BOARD WORK SESSION

1. **CALL TO ORDER:** Chair Bill Middleton called the meeting to order at 6:03 pm.
2. **BOARD PRESENT:** Chair Bill Middleton, Linda Henderson, Bill Butterfield, Matt Langer, David Grant, and Robyn Folsom. Krisanna Clark arrived at 6:10 pm
3. **STAFF PRESENT:** City Manager Joseph Gall, Assistant City Manager Tom Pessemier, Community Services Director Kristen Switzer, Community Development Director Julia Hajduk, Administrative Assistant Colleen Resch and Agency Recorder Sylvia Murphy.
4. **OTHERS PRESENT:** Scott Waggoner with Ankrom Moisan, Tobin Cooley with Listen Acoustics and Paul Luntsford with PLA Design.
5. **TOPICS DISCUSSED:**

A. Community Center Update

Tom Pessemier Assistant City Manager informed the Board the purpose of the meeting was to present information on the uses of the center based on the design. Tom explained the history of the project, from the original purchase of the machine works building with the intent to renovate and due to cost, the current status of the project to build as new. He explained the process of going through the plan review at the planning commission level and working on construction drawings and developing the concept to be presented tonight. He explained the schedule moving forward, subject to any changes of the Board tonight, is to submit construction drawing documents to the building department this week.

Tom said plans have been submitted to the planning department which will be going before the Planning Commission. He said this is a site plan modification because we have already gone through site plan approval process for the other building and said we are just making modifications to the site plan application to identify changes. He said this is scheduled at the Planning Commission level for Oct 8th with a public hearing. He said staff expects construction cost estimates within a few weeks and said no issues are anticipated at this time and said the bid package is estimated to go out the first part of November with contract approvals coming before the City Council in December and moving forward with construction in January and an opening date of late fall, early winter 2014.

Scott Waggoner with Ankrom Moisan came forward and presented information (see record, Exhibit A) and briefed the Board on the shape of the building and plaza space. He briefed on the site plan, retail space, and parking spaces. He briefed on the exterior of the building and lobby space. He explained the interior of the building, with approximately 400 seats in a performance layout format with telescopic seating. He said the lobby is approx. 16 x 60, with a main hall area and class rooms. He explained the leasable space options. He explained the backup house for the stage with dressing rooms for performances. He showed the interior perspectives and explained possible uses for the space with

banquets, receptions and meetings and explained storage areas. Scott explained the upper level with sound booth and tech space and an additional class room, and storage space. He explained the materials proposed for the exterior of the building as brick, aggregate block, glass and steel.

Tobin Cooley with Listen Acoustics came forward and explained acoustical components and the various types of panels and functions of the different panels. He explained the speakers and speaker type and proposed locations. He briefly explained the audio and video system locations and simplicity of the system. He explained the sound booth space and audio visual control with touch screen, and two available modes.

Paul Luntsford with PLA Design came forward and spoke of simplicity of space use and functionality. He briefed on seating and having it deployed or stored and having a flat floor with portable seating that is motorized. He explained the seats as being upholstered, padded with armrests. He explained stage rigging and pipe grid and functionality of the pipe grids as well as flexibility. He explained masking, draping, curtains and tracking. He explained the tracks for light positioning. He explained the control console for the lighting, touch screens, dimmer bars and costs savings associated with the dimmer bars. He further explained the control console and functionality and infrastructure. He explained LED lights and said the system is layered, scalable and easy to use and can be found in many schools, centers and all over the region.

Scott Waggoner provided additional information on the lobby area and corridor, lighting, natural lighting and multi-use functionality with walls for displaying art. He explained the hall way and it's functionality and lighting of this area with opportunity to hang things on the wall.

Tom explained the classrooms and flooring and proposed classrooms with sinks. He explained the plan to open the building in late fall early winter and said it won't be totally completed and basic functions are being provided and we will have the ability to add onto the building in the future. He spoke of potential grants and seeking them in the future and spoke of the flexibility of the facility.

He thanked Councilor's Butterfield, Folsom and Henderson for spending a lot of time helping to develop this project as well as thanked Kristen Switzer, Bob Galati and Brad Crawford.

Tom commented regarding the efforts to get a retailer into the building and said they were not too far from this effort. He offered to answer Board questions.

Mr. Grant asked regarding the co-location facility and if this was still planned. Tom replied it was decided early on from talking with Council members and others that it was more important to have classroom space.

Ms. Henderson asked the URA Board for their thoughts on how the building fits into the old town area. Tom replied and said the Planning Commission will be taking public testimony in regards to this question and if there's an appeal of that decision, it would come to the Board. He said he appreciates the question, but there will be public conversation about this and the Board can then make a decision. He restated the question as to "does anyone have any objection to it".

Mr. Butterfield stated from day one, we have worked hard to make sure what we did fit into our community and this has been in our thoughts from the first conceptual stage.

Ms. Folsom commented regarding photo's provided by the architects and their attempts to try and tie them to focal points in the community. She commented regarding the mini plaza area and it complimenting what we already have. She commented regarding comments she had heard with the new wide sidewalks, their usefulness and trying this all together.

She asked regarding the life of a light fixture and its replacement period, and cost of light bulbs. Paul replied and provided information regarding the life of the fixtures being a long time and gave examples, the cost of a bulb being \$14-\$28 and said LED bulbs would last 30-60 years. She asked regarding lighting opportunities in the audience space. Paul replied and said there were three bars and explained their location and functionality. She commented regarding having the ability to add lighting in the future. Paul replied regarding the importance of establishing the infrastructure and having the ability to add in the future.

Ms. Folsom asked regarding the flooring, Tobin replied. She asked regarding the defusing panels and deflecting panels and their efficiency, and asked with the polished concrete floor would more panels need to be added. Tobin replied and commented regarding the ceiling using acoustic absorption and explained the absorption of the other surfaces. Ms. Folsom commented regarding not having a raised stage and the flexibility that allows for the facility. Paul replied and confirmed the flexibility and commented regarding accessibility. Discussion followed regarding examples of other facilities and their functionality and Ms. Folsom stated she feels for our community and the usefulness of it, it will be a great way to proceed.

Tom added regarding choral events and controlling costs and for choral events a shell would probably be needed to project sound. Paul replied regarding portable shells and fitting through a standard doorway. Tobin further explained shells and their reflectors and space being more effective without affecting the remainder of the facility space. Tobin added that some seats are absorptive as well.

Ms. Henderson asked regarding future acoustical improvements and knows where to hang equipment. Tobin replied and said the design team is available to assist and the room supports it.

Tom explained the next steps of getting construction drawings, going through the planning process and coming back to the Board to sign construction contracts in December.

Chair Middleton thanked the group for their work and adjourned the work session.

6. ADJOURN:

Chair Middleton adjourned the meeting at 7:00 pm.

Submitted by:

Sylvia Murphy, MMC, Agency Recorder

Bill Middleton, Chair