



TECHNICAL MEMORANDUM

TO: Ken Theissen, Oregon Department of Environmental Quality
FROM: Erin Waibel, RG; Jesikah Cavanaugh, EIT
CC: Debbie Taege, The Boeing Company
DATE: October 2, 2023
RE: Work Plan
Additional SVE Well Installation
Former Vapor Degreaser Source Area
Boeing Portland Troutdale Gravel Aquifer
Gresham, Oregon
Project No. 025116.123.210

INTRODUCTION

This work plan presents procedures for Landau Associates, Inc. (Landau) to install additional wells for monitoring and extracting subsurface vapor within the former vapor degreaser source area (FVDSA) in the 85-001 building at The Boeing Company's (Boeing) Portland facility (Figure 1). The purpose of installing additional wells is to focus soil vapor extraction (SVE) in the area with the highest remaining vapor concentrations of volatile organic compound (VOC)-impacted subsurface soil (primarily impacted with trichloroethene [TCE]) near the former vapor degreasers (source of contamination). The SVE system was installed in September 2012, expansion will aid in optimization of the SVE system by focusing extraction in the vadose zone near the source of contamination. Additional investigation was completed in 2020 and 2021 following the Oregon Department of Environmental Quality (ODEQ)-approved Shallow Investigation Work Plan (Landau 2020). Following review of additional data, SVE system optimization was recommended including installation of additional SVE wells.

Background

The SVE system began operating on a full-time basis in September 2012. To monitor the performance of the SVE system, routine soil vapor samples are collected from two depth intervals: sub-slab (directly beneath the building's concrete slab) and at-depth (5 feet [ft] below ground surface [bgs] to 45 ft bgs). In 2014, operation of the SVE system was switched from full-time to a pulsing approach, as approved by ODEQ, which consists of periodic shutdowns to the entire system based on analytical data exceeding applicable risk-based concentrations (RBCs).

In December 2020, shallow soil sampling and installation of nine additional sub-slab vapor points was completed. Soil samples were collected within 5 ft bgs and demonstrated that the residual TCE source is not within the shallow vertical range sampled (64.5 micrograms per kilogram [$\mu\text{g}/\text{kg}$], nearly two orders

of magnitude below the applicable RBC of 2,300 µg/kg). Rebound testing at all vapor points, vapor observation wells, and multiple-purpose wells was conducted from February 17 through April 8, 2021. Rapid, high level increases in TCE concentrations at vapor points VP-6 and VP-13, followed by less immediate but high-level increases at vapor points VP-5 and then VP-1 (which are likely farther from the source), indicate a relatively localized area of VOC contamination that remains in the vadose zone proximate to the south and to the west of the former vapor degreasers. During the final sampling event of the rebound test (7 weeks post-system shutdown), 12 of the 22 sample locations demonstrated TCE concentrations above 100 micrograms per cubic meter (µg/m³; Figure 2).

Based on the 2021 rebound testing analytical results and routine sub-slab soil vapor monitoring data, given sufficient time, SVE system shutdown likely would cause rebound in concentrations similar to baseline prior to SVE implementation at few locations (Landau 2022a). The significantly higher rebound concentrations at sub-slab vapor points compared to at-depth monitoring locations may indicate that residual contaminant mass is located within the shallow subsurface. Given the rebounding concentrations to levels observed before SVE treatment was implemented, it appears the SVE system would benefit from additional soil vapor extraction wells near the former vapor degreasers.

PRE-FIELD ACTIVITIES

The following subsections outline tasks that must be completed prior to the start of invasive field tasks (i.e., drilling and sampling).

Health and Safety Plan

Landau employees will follow the procedures described in the site-specific health and safety plan (HASP; Landau 2022b). Landau's subcontractors will prepare their own HASPs or choose to adopt the HASP prepared by Landau.

Boeing Documentation

Applicable Boeing documentation will be completed and submitted to the appropriate field engineer and consist of the following:

- Boeing Project-Specific Environmental, Health, and Safety Plan with attachments, as appropriate (Solid Waste Management Plan, Air Quality Plan, Wastewater Plan);
- Boeing Pre-field Checklist;
- Boeing Safety Dashboard Card;
- Good-faith inspections for asbestos and metals; and
- Pre-Dig Checklist.

Utility Clearance

Prior to initiation of any invasive subsurface activity, the locations of each proposed boring will be checked in the field to locate aboveground utilities or physical limitations that would prevent drilling at

the proposed location. Landau will coordinate with Boeing Facility personnel to check the proposed boring locations for potential obstructions using available facility drawings.

A public utility locate service will be contacted to locate public underground utilities at the site and a private utility locate service will be contacted to locate underground utilities near the proposed soil boring and trenching locations. Locations will be relocated, as needed, to avoid utilities and meet the objectives of the SVE expansion.

ADDITIONAL SVE WELL INSTALLATION

Landau proposes the construction of three additional extraction wells (SVE-1 through SVE-3) and to convert one SVE monitoring well into an extraction well (VOW-18/SVE-4) to allow for targeted mass removal (Figure 3). The following sections outline the tasks to complete for SVE system expansion and optimization.

Drilling and Well Installation

Similar to the original SVE well design, three borings will be advanced and wells installed using a rotasonic drilling rig with an 8-inch diameter drill casing for 4-inch completed wells in accordance with the ODEQ-approved Environmental Strategic Plan (Landau 2008) and Oregon Water Resources Department regulations. Well installation will be performed by an Oregon-licensed driller and overseen by a Landau environmental professional. During drilling, a continuous soil core will be collected in a 6-inch diameter core barrel, which is placed in a polyethylene “core bag” liner. Between samples, the core sampler and all drilling equipment (e.g., rods, casing, etc.) will be cleaned using a three-step process, as follows:

1. Scrub surfaces of equipment that would be in contact with the sample with brushes using an Alconox solution.
2. Rinse and scrub equipment with clean tap water.
3. Rinse equipment a final time with de-ionized water to remove tap water impurities.

Decontamination will occur between the completion of each boring.

Soil lithology will be documented from the soil core and described in accordance with the United Soil Classification System (ASTM International [ASTM] D2487) using the visual-manual procedure for describing soils (ASTM D2488). Environmental field screening will consist of visual and olfactory observations (sheen and odor) as well as photoionization detector (PID) headspace analysis and will be recorded on the exploration log. Headspace analysis will be conducted by placing a representative portion of the soil from every 2-ft interval in a sealable plastic bag, allowing the soil to off-gas inside the sealed bag for 5 minutes, then inserting the PID tip into the bag to measure total VOCs.

SVE wells will be advanced to a maximum depth of 40 ft bgs to avoid reaching the saturated zone and up to three subsurface soil samples will be collected at each boring. Soil sample depths will be based on the results of the field screening. Soil samples will be collected in laboratory-supplied jars and submitted to Eurofins Lancaster Laboratories Environment Testing, LLC. Samples will be analyzed for Boeing 38 list

VOCs using US Environmental Protection Agency (EPA) Method 8260. Between samples, soil sampling equipment (e.g., stainless-steel bowls, stainless-steel spoons, etc.) will be cleaned using the three-step process noted above. Decontamination will occur between the collection of each sample.

SVE extraction wells will be installed within the vadose zone and the recommended expansion is based on SVE monitoring data and an anticipated approximate effective radius of influence of 10 ft (results from the previous SVE pilot test data; Landau 2010). The locations of the proposed wells are shown on Figure 3 and were chosen based on their proximity to the vapor pins with the highest and most quickly rebounding concentrations of VOCs during the 2021 rebound testing.

The SVE wells will be constructed of 4-inch diameter polyvinyl chloride (PVC) casing with a 10-ft screened interval of 0.020-inch slotted PVC screen and sand filter pack material in the borehole annulus to 3 ft bgs. The vadose zone screen will be determined based on the maximum VOC readings recorded using the PID or any visual or olfactory observations made during field screening. Screened intervals will start at a minimum of 5 ft bgs. The depth of explorations and the wells will be 35 ft bgs, unless the field screening collected at 35 ft bgs indicates deeper contamination, then the boring will be advanced an additional 5 ft. If there is not a clear indication of contamination via field screening, the following screen depths will be used:

- SVE-1 will be screened from 5 ft bgs to 15 ft bgs.
- SVE-2 will be screened from 25 ft bgs to 35 ft bgs. This boring is located within the approximate area of a former basement associated with decommissioned machinery.
- SVE-3 will be screened from 5 ft bgs to 15 ft bgs.
- SVE-4/VOW-18 has already been established (Attachment 1) and is screened from 5 ft bgs to 44 ft bgs.

A seal of bentonite chips will be installed from the top of the vadose zone screen filter pack material to within 1 ft of the concrete slab. A flush, protective vault will encase the top of the casing and piping connecting the wells to the SVE system. Well construction diagrams are presented on Figures 4 and 5.

Well Head Construction

In addition to the newly installed SVE wells, VOW-18 will be converted to an extraction well. Each new extraction well will be equipped with a manifold with a flow control valve, pressure gauge, and sample port for monitoring within the protective vaults. The manifold will be piped to the existing SVE equipment consisting of a moisture knock-out tank (condensate separator); a regenerative blower; granular activated carbon (GAC) treatment vessels; and discharge stack with sampling port, flow meter, and temperature gauge. A schematic of the SVE system and equipment is included as Figure 4.

Piping from the SVE wells will be run belowground (through trenches) until meeting the existing pipe leading to the designated blower and SVE system area. SVE piping will be constructed of Schedule 80 PVC. Bedding material will be placed and compacted around the piping. The remainder of each trench will be backfilled, compacted, and repaved with concrete to match existing conditions.

SVE interconnection piping will be constructed of Schedule 80 PVC with unions or flex hose with cam-lock fittings. The existing discharge stack runs up the wall near Column H-36 through an existing roof vent/duct. The primary SVE equipment includes the following:

- Rotron EN 858 BD72WL regenerative blower;
- 55-gallon knockout tank; and
- Two 2,000-pound GAC vessels, connected in series.

Well Startup Testing

Each time the SVE system is started up, all valves from the SVE wells to the treatment system will be open (unless specific wells are to be excluded from operation) and the ambient air dilution valve will be open. After the blower has been activated and initial flow has been established, the dilution valve will be closed until desired flow rates from the wells are achieved. All wells can be throttled down with individual flow control valves on each of the well pipes leading to the system. Pressures and flow rates for each well should be verified after startup. The Rotron blower is capable of approximately 80 to 100 inches of water vacuum at a flow rate of 10 cubic ft per minute (cfm).

SVE system monitoring will be performed within 1 hour, 24 hours, and 1 week after system startup, then monthly thereafter. Monitoring will consist of collecting system pressure, temperature, and flow meter readings, and monitoring VOC concentrations in vapor from extraction wells and the vapor treatment system. Specifically, the following will be monitored and recorded on a log sheet:

- Pressure (or vacuum) readings will be collected, using a Magnehelic® gauge from each new extraction well, observation well, multiple-purpose well, before and after the blower, and after each GAC vessel.
- Temperature readings will be collected, using a permanently mounted temperature gauge, from before and after the blower, and after each GAC vessel.
- Flow readings will be collected, using a permanently mounted flow meter or anemometer, from before and after the blower, and after each GAC vessel.

The moisture knockout tank will be monitored for moisture accumulation and emptied, as needed. Because the tank is under vacuum, the blower may need to be temporarily shut down to drain the tank. Approximate volumes evacuated will be recorded. The knockout tank will be manually drained into a bucket or tote and transferred to the decontamination pad in the remediation yard for treatment through the groundwater treatment system.

These measurements and readings will be evaluated for general system operations and for general trends in pressure from individual wells and the system.

System Monitoring and Sampling Plan

The new and converted extraction wells will be monitored semiannually as part of the routine TGA remedy monitoring. Prior to sampling, the SVE system will be shut off for at least 24 hours to allow for

subsurface vapor/pressure equilibration. Sampling will be conducted in accordance with the sampling and analysis plan (Landau 2012) as described below.

Sub-slab vapor samples will be collected in 1-liter Summa canisters and sent to Air Toxics laboratory of Folsom, California to be analyzed for VOCs by EPA Method TO-15. Sub-slab vapor samples will be collected as described in the previously ODEQ-approved work plan for the previous investigations and the ODEQ Guidance for Assessing and Remediating Vapor Intrusion in Buildings (ODEQ 2010). A hand pump will be connected to sample point Teflon tubing and a minimum of 2 volumes (i.e., the volume of the tubing and core) will be purged prior to sampling. The valve on the sample tubing will be opened to perform the purge and then closed. Each Summa canister will be connected to the tubing with a Swagelok fitting and the valve on the sample tubing and the needle valve on the Summa canister will be opened to collect the sample.

After the needle valve has been open for approximately 5–6 minutes (a flow rate of 167 milliliters per minute [mL/min] will not be exceeded) and adequate volume of vapor has been collected, the needle valve will be closed, and the Summa canister will be detached. The initial and final canister vacuum will be recorded on the chain-of-custody form that is sent to the laboratory with the canisters. For the sample to be valid, the initial canister vacuum must be greater than 25 inches of mercury (inHg; typically, the laboratory ships the canisters with approximately 29.9 inHg), and the final canister vacuum will be between 2 and 6 inHg. The tubing will be removed, and the vapor point valve will be closed prior to replacing the protective cap.

Samples will be submitted for laboratory analysis of a short list of VOCs. Vapor samples will be submitted to Eurofins Air Toxics for laboratory analysis for VOCs by EPA Method TO-15 for the TGA remedy VOC compounds of interest only: TCE; cis-1,2-dichloroethene (cDCE); vinyl chloride (VC); trichloroethane (TCA); tetrachloroethene (PCE); and 1,1-dichloroethene (1,1-DCE). Reporting limits for these compounds by Method TO-15, for samples collected in 1-liter canisters, range from 2.9 to 7 $\mu\text{g}/\text{m}^3$. These reporting limits are low compared to the RBCs and are therefore adequate for this investigation.

INVESTIGATION-DERIVED WASTE

Investigation-derived waste (IDW) resulting from SVE well drilling activities will consist of soil cuttings and water. IDW soil will be placed in Oregon Department of Transportation (ODOT)-approved 55-gallon drums or suitable soil box. Decontamination of all sampling equipment will be conducted on the Decontamination Pad located in the Boeing Remediation Yard. Decontamination water generated during sampling activities will be treated through the onsite groundwater extraction treatment system. All non-disposable personal protective equipment and sampling equipment will be washed with an Alconox soap and tap water mixture and rinsed with distilled water. Concrete cores will be disposed in accordance with Boeing's Solid Waste Segregation Direction. All drums will be properly labeled at the end of each day. IDW samples will be collected, as needed, in consultation with Boeing prior to disposition by Boeing.

DATA EVALUATION AND REPORTING

Data evaluation and reporting of sampling activities and findings will be included in the annual progress report for the TGA remedy. Data will be evaluated to assess the effectiveness of the SVE system expansion. Results and recommendations will be provided to ODEQ for consideration.

SCHEDULE

It is anticipated that the additional well installation and trenching associated with the SVE expansion described in this work plan will be conducted during the Boeing holiday shutdown in late-December 2023/early-January 2024. System startup is planned for January 2024, the first vapor sampling event will be conducted in the first quarter of 2024 in conjunction with the routine semiannual vapor sampling event in February 2024.

LIMITATIONS

This technical memorandum has been prepared for the exclusive use of Boeing for specific application to the additional SVE well installation at the Building 85-001 FVDSA of the Boeing Portland facility. No other party is entitled to rely on the information, conclusions, and recommendations included in this document without the express written consent of Landau. Further, the reuse of information, conclusions, and recommendations provided herein for extensions of the project or for any other project, without review and authorization by Landau, shall be at the user's sole risk. Landau warrants that within the limitations of scope, schedule, and budget, our services have been provided in a manner consistent with that level of care and skill ordinarily exercised by members of the profession currently practicing in the same locality under similar conditions as this project. Landau makes no other warranty, either express or implied.

LANDAU ASSOCIATES, INC.



Jesikah Cavanaugh, EIT
Project EIT



Erin Waibel, RG
Associate Geologist

JEC/EMW/ljl

[P:\025\116\FILERM\R\TGA\FORMER DEGREASER AREA\2023 SVE WELL INSTALL WP\LANDAU_BOP_ADD SVE WELL INSTALL WP_FINAL 100223.DOCX]

Attachments

Figure 1: Boeing Portland Site Map
Figure 2: 2021 SVE Rebound Results—Isoconcentration Contours
Figure 3: Proposed Locations for New Extraction Wells
Figure 4: Schematic of SVE System
Figure 5: SVE Details
Attachment 1: VOW-18 Boring Log

References

Landau. 2008. Environmental Strategic Plan, 85-001 Building Expansion, Boeing Portland, Gresham, Oregon. Landau Associates, Inc. March 28.

Landau. 2010. Environmental Subsurface Investigation, Building 85-001 Former Degreaser Area, Boeing Portland Facility, Portland, Oregon. Landau Associates, Inc. July 22.

Landau. 2012. Sampling and Analysis Plan, Troutdale Gravel Aquifer, Boeing Portland Facility, Gresham, Oregon. Landau Associates, Inc. Revised September 26.

Landau. 2020. Technical Memorandum: Work Plan: Shallow Subsurface Investigation, Building 85-001 Former Vapor Degreaser Source Area, Boeing Portland, Gresham, Oregon. Landau Associates, Inc. November 20.

Landau. 2022a. Final SVE Optimization Report, Former Vapor Degreaser Source Area, Boeing Portland Troutdale Gravel Aquifer, Gresham, Oregon. Landau Associates, Inc. February 25.

Landau. 2022b. Health and Safety Plan, Boeing Portland, Gresham, Oregon. Landau Associates, Inc. Revised August 31.

ODEQ. 2010. Final Guidance for Assessing and Remediating Vapor Intrusion in Buildings. Oregon Department of Environmental Quality, Environmental Cleanup Program. March 25.

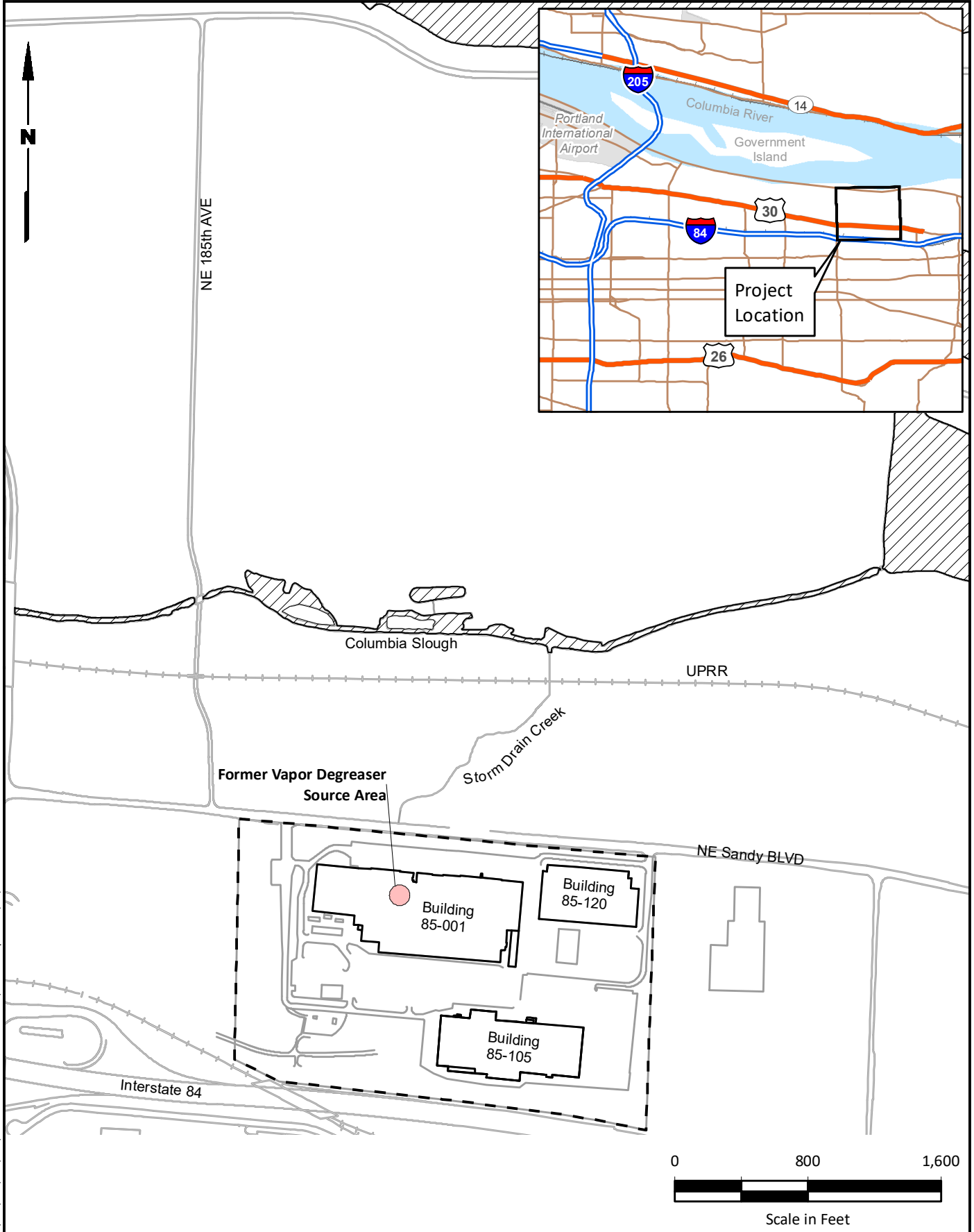

G:\Projects\025\116\123\210\Additional SVE Well Installation\01_VicMap.mxd 8/14/2023

Landau Associates | G:\Projects\025\116\123\10\Additional SVE Well Installation\F02 IsoconcentrationContours.dwg | 9/28/2023 3:00 PM | ezick

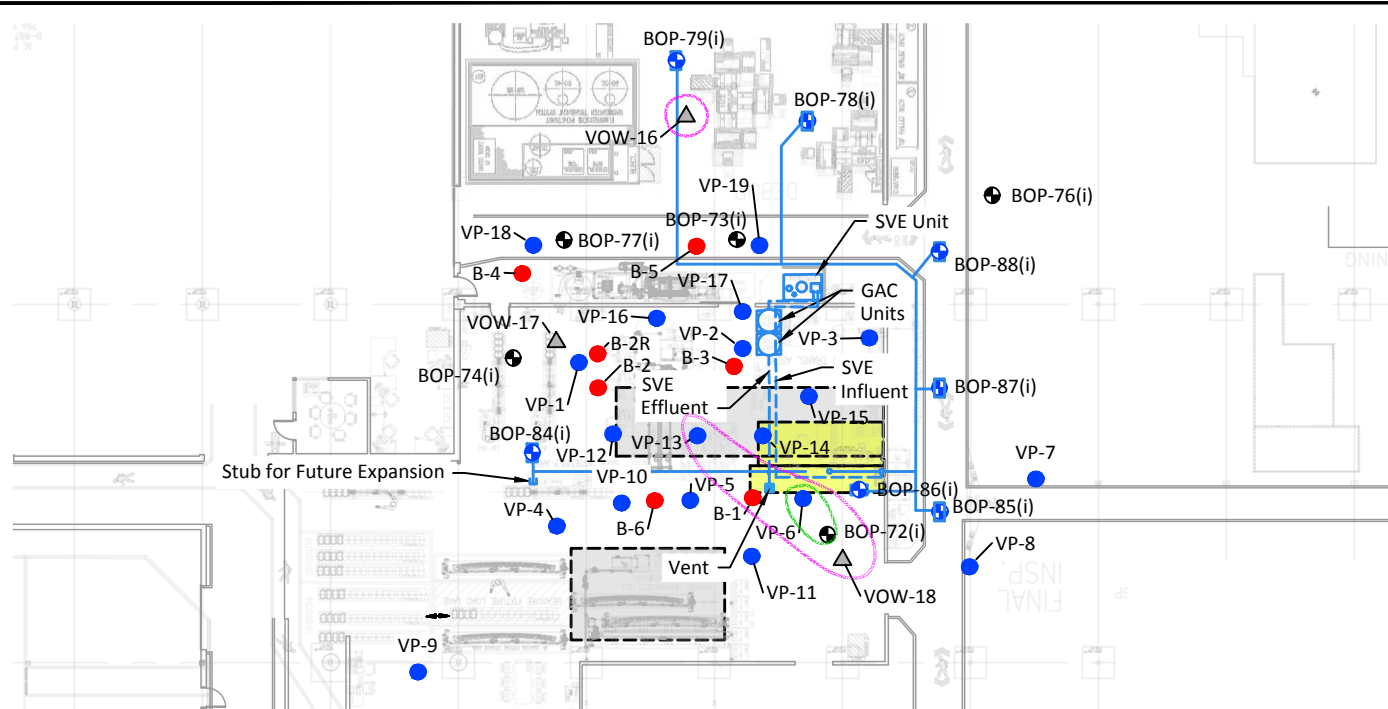

February 18, 2021 (24 hours post-shutdown)

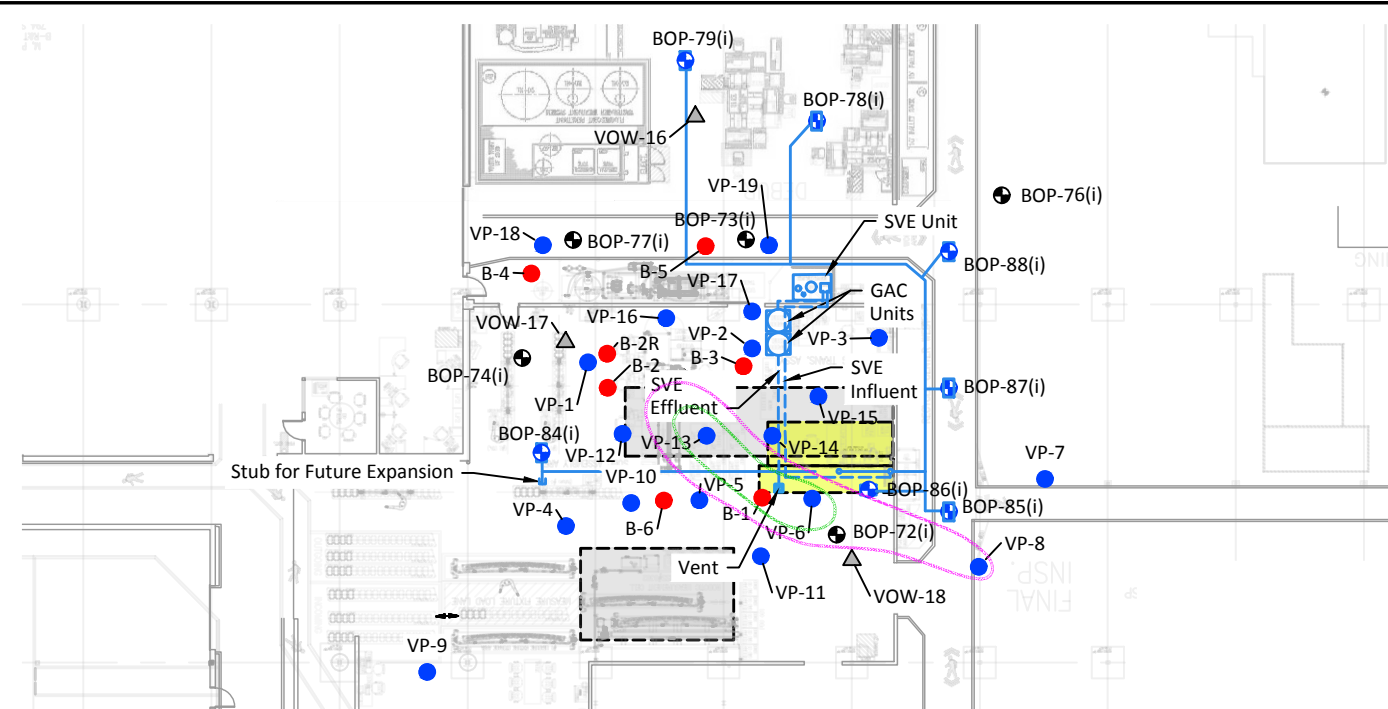

February 24, 2021 (1 week post-shutdown)

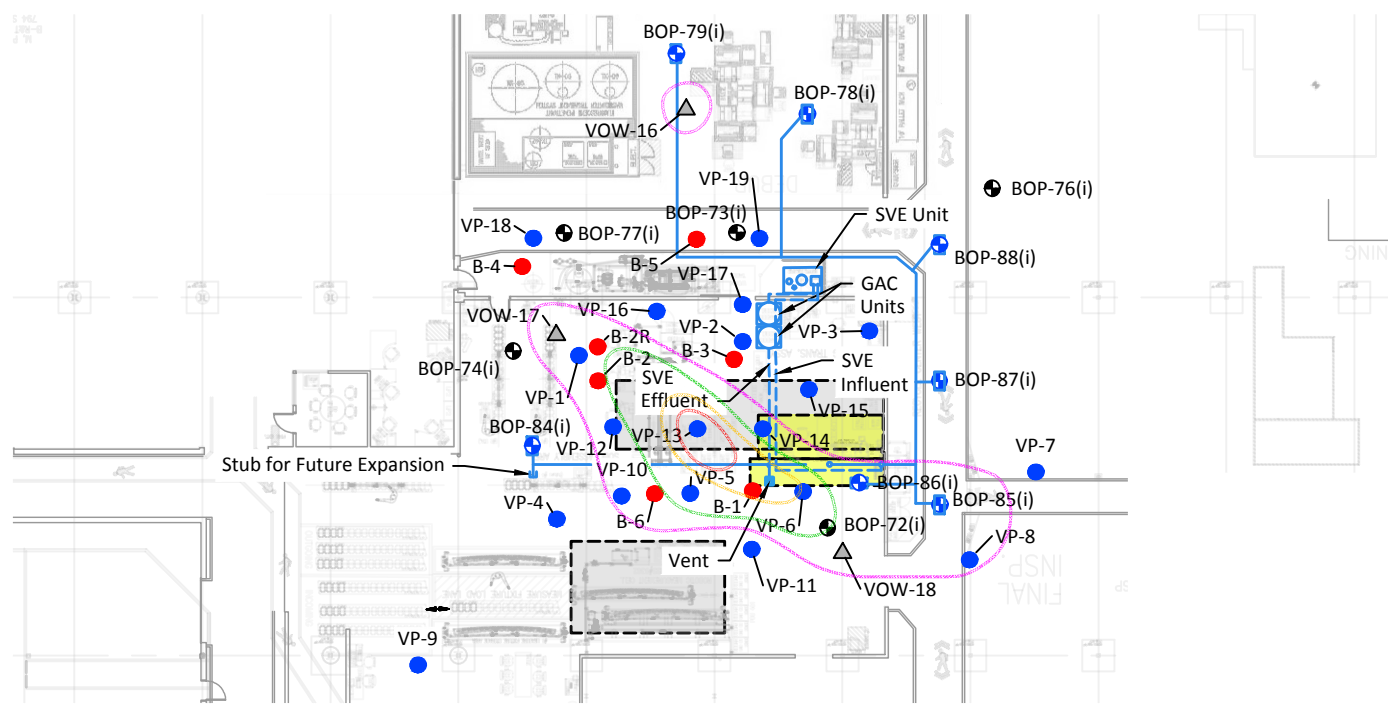

March 18, 2021 (4 weeks post-shutdown)

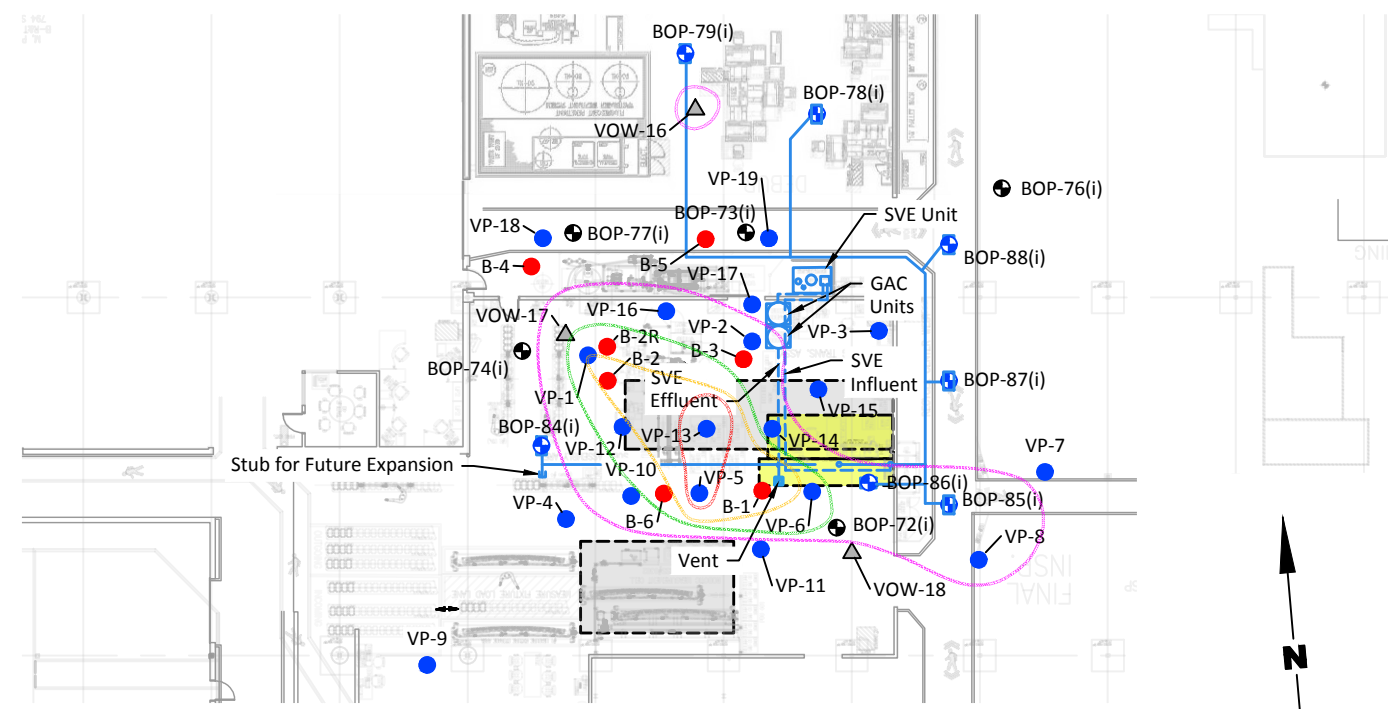

April 8, 2021 (7 weeks post-shutdown)

Legend

- | | | |
|--|---|--|
| — 5000 µg/m ³ | ● Soil Boring (5 ft below ground surface) Location | Approximate Location of Basements |
| — 2900 µg/m ³ | ● Sub-Slab Vapor Pin Location | Approximate Location of Former Degreasers |
| — 500 µg/m ³ | ⊕ Multiple-Purpose SVE and Monitoring Well Location | — Below-ground SVE Piping |
| — 100 µg/m ³ | ⊙ Monitoring Well Location | - - - Above-ground SVE Piping |
| | △ Vapor Observation Well Location | |

Note

1. Black and white reproduction of this color original may reduce its effectiveness and lead to incorrect interpretation.

Source: The Boeing Company

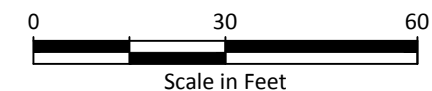

Landau Associates | G:\Projects\025\116\123\1210\Additional SVE Well Installation\F03 New Extraction Well Locs.dwg | 10/1/2023 11:26 PM | ezick

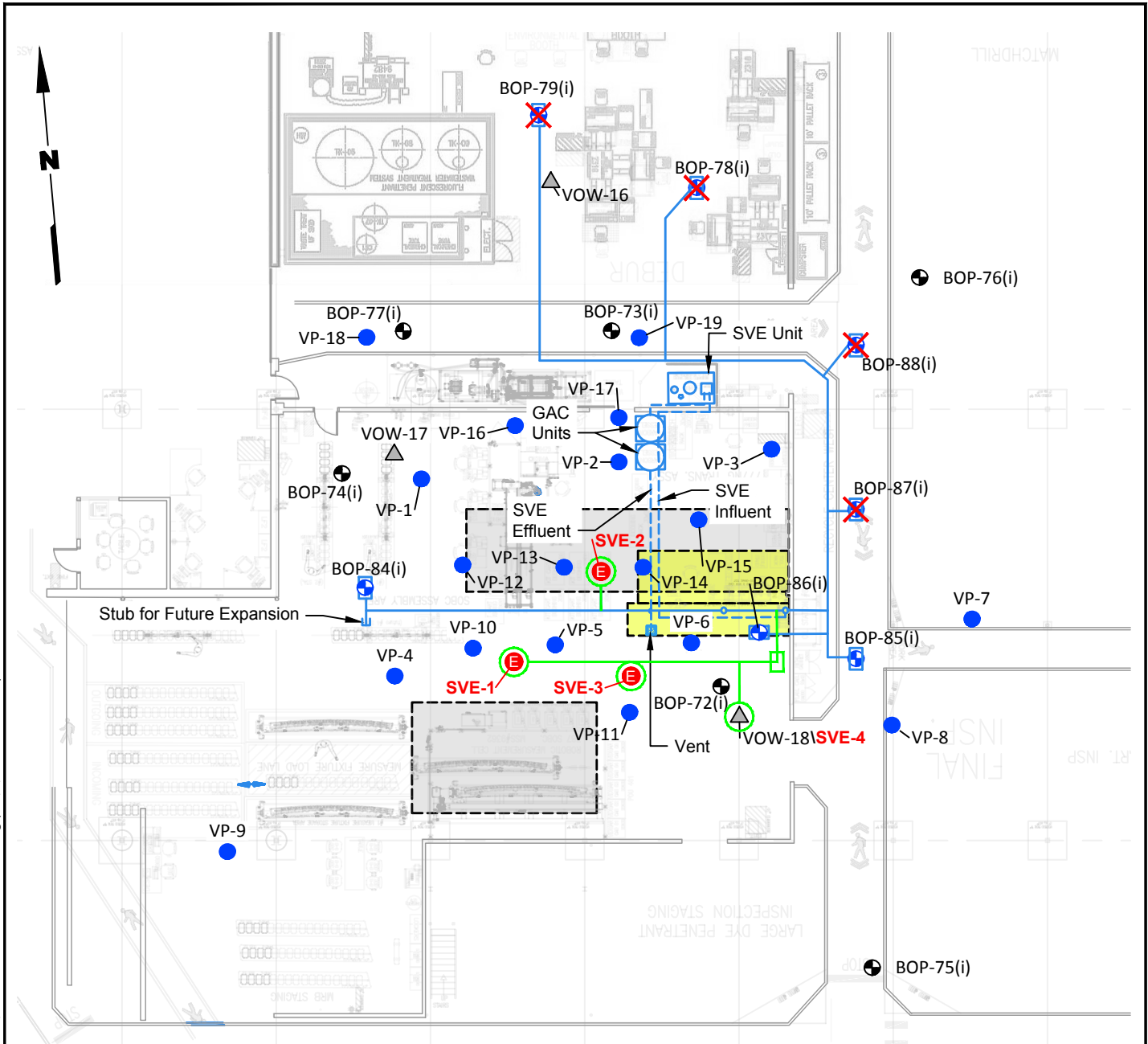

Legend

- New Soil Vapor Extraction Well
- ✗ Soil Vapor Extraction Well (shut down)
- ⓔ Soil Vapor Extraction Well
- Sub-Slab Vapor Pin Location
- ⊕ Multiple-Purpose SVE and Monitoring Well Location
- ⊙ Monitoring Well Location
- ▲ Vapor Observation Well Location
- New SVE Piping
- Below-ground SVE Piping
- - - Above-ground SVE Piping
- Approximate Location of Basements
- Approximate Location of Former Degreasers

Note

1. Black and white reproduction of this color original may reduce its effectiveness and lead to incorrect interpretation.



Source: The Boeing Company



Boeing Portland
Gresham, Oregon

**Proposed Locations for
New Extraction Wells**

Figure
3

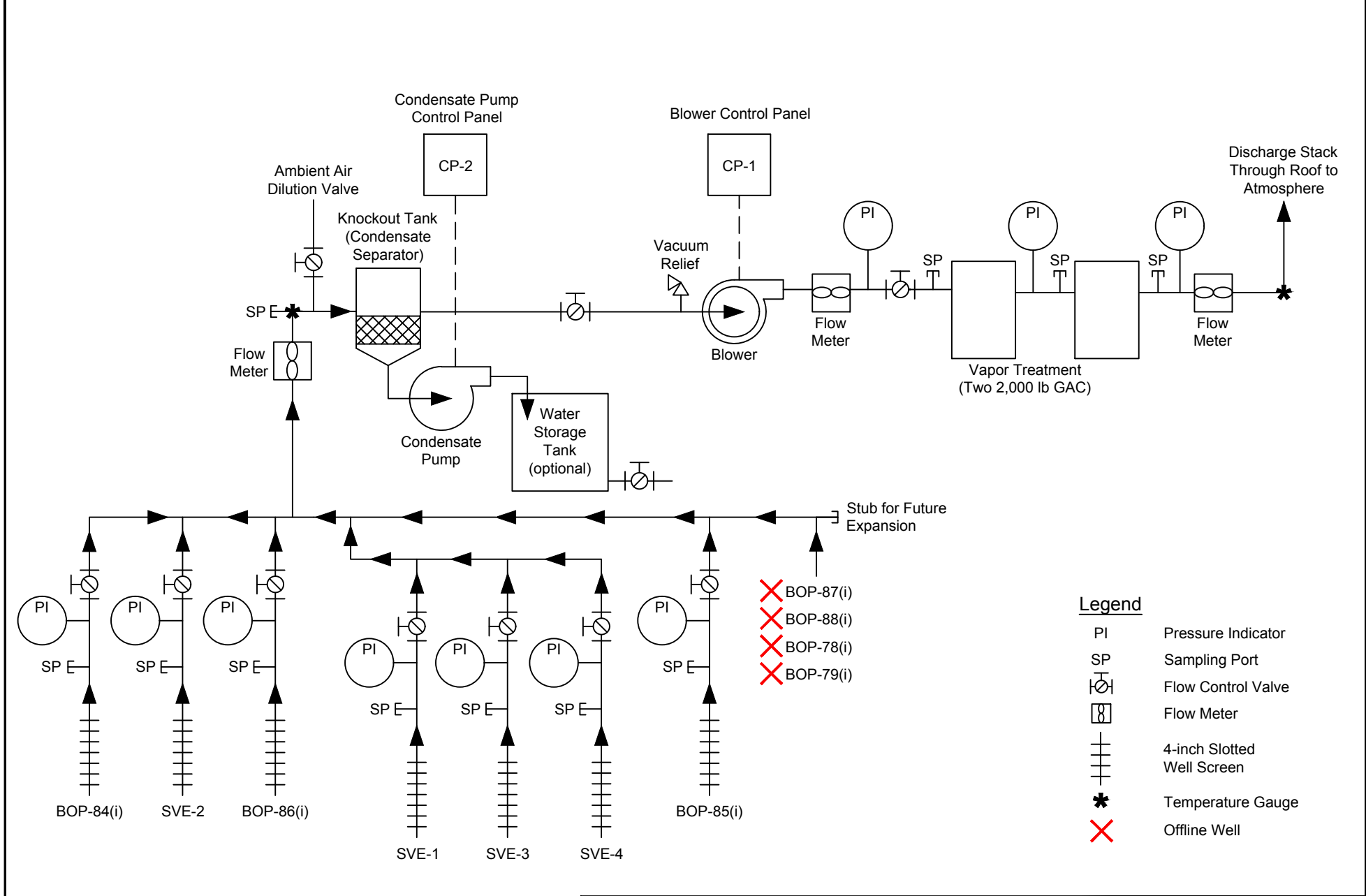

G:\Projects\025\116\123\Additional SVE Well Installation\F05 SVE Details.dwg | 8/15/2023 9:18 AM | ezick

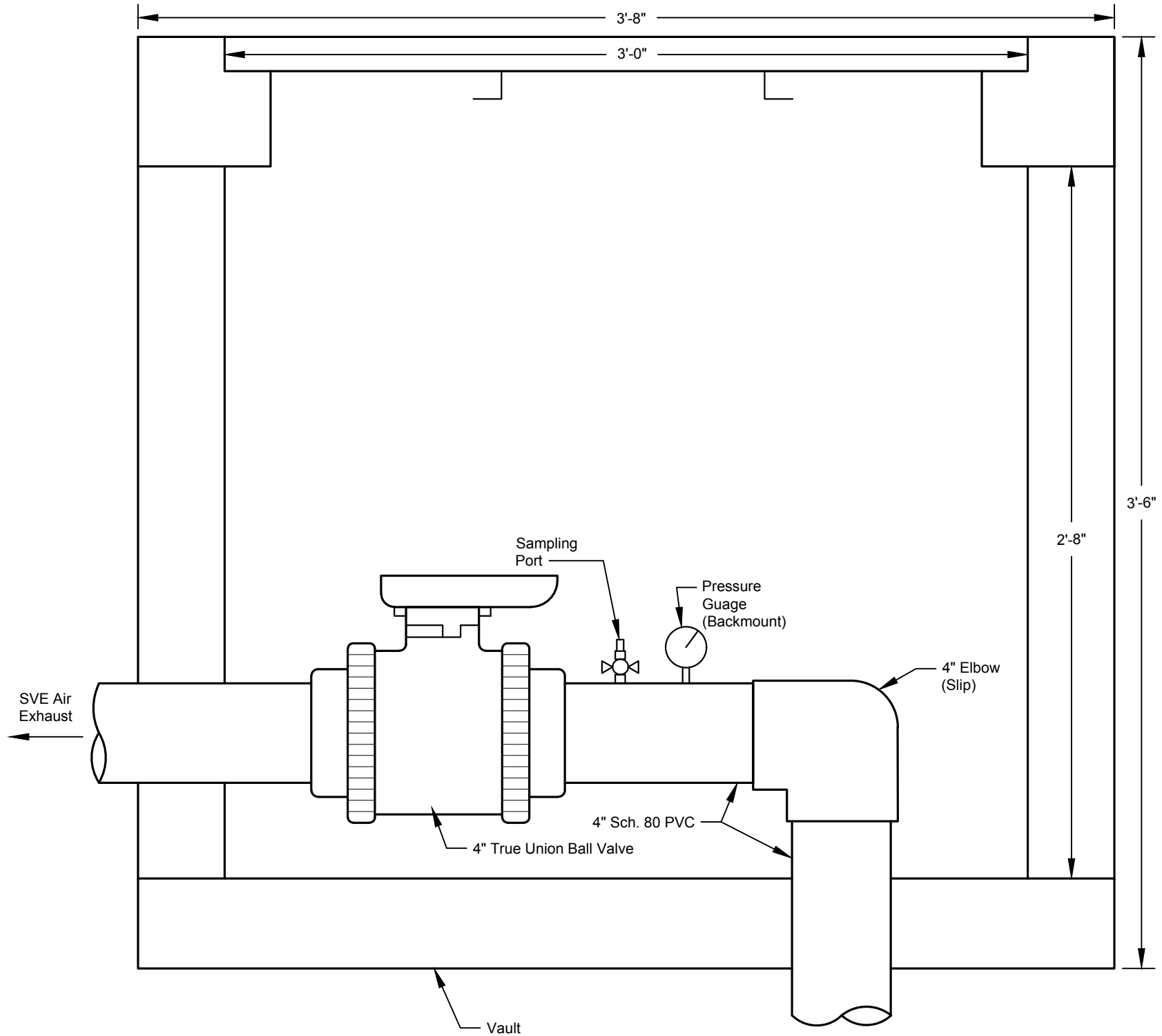

Typical Wellhead Vault

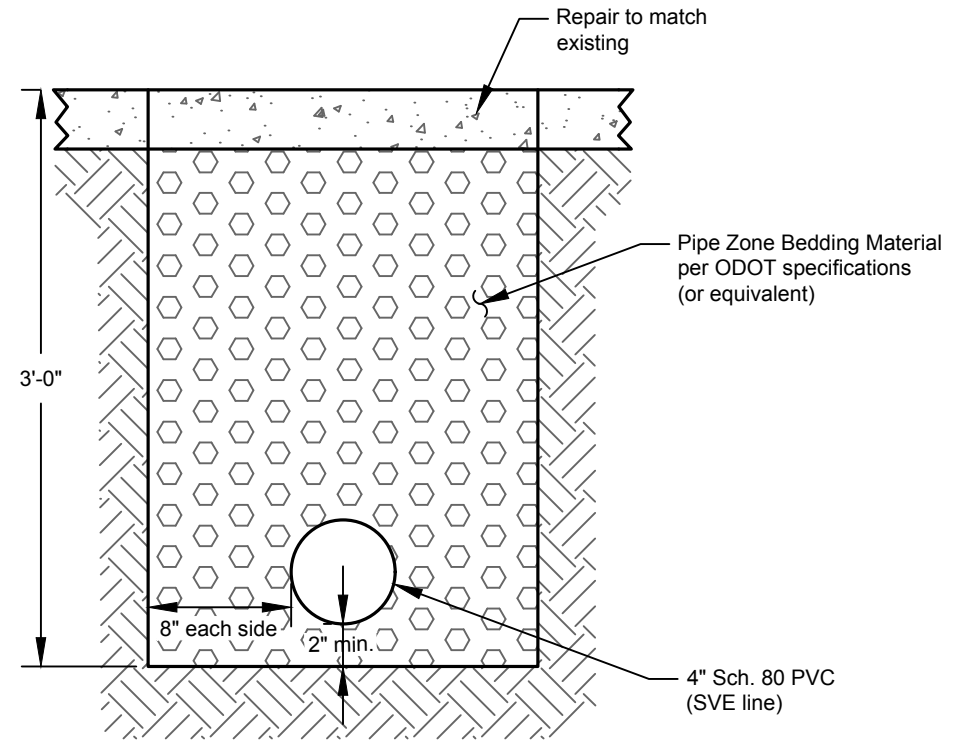
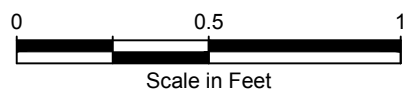

Typical Trench Section



Note

- 1. Slope all pipes toward well at approx. 1% slope.

ATTACHMENT 1

VOW-18 Boring Log

VOW-18

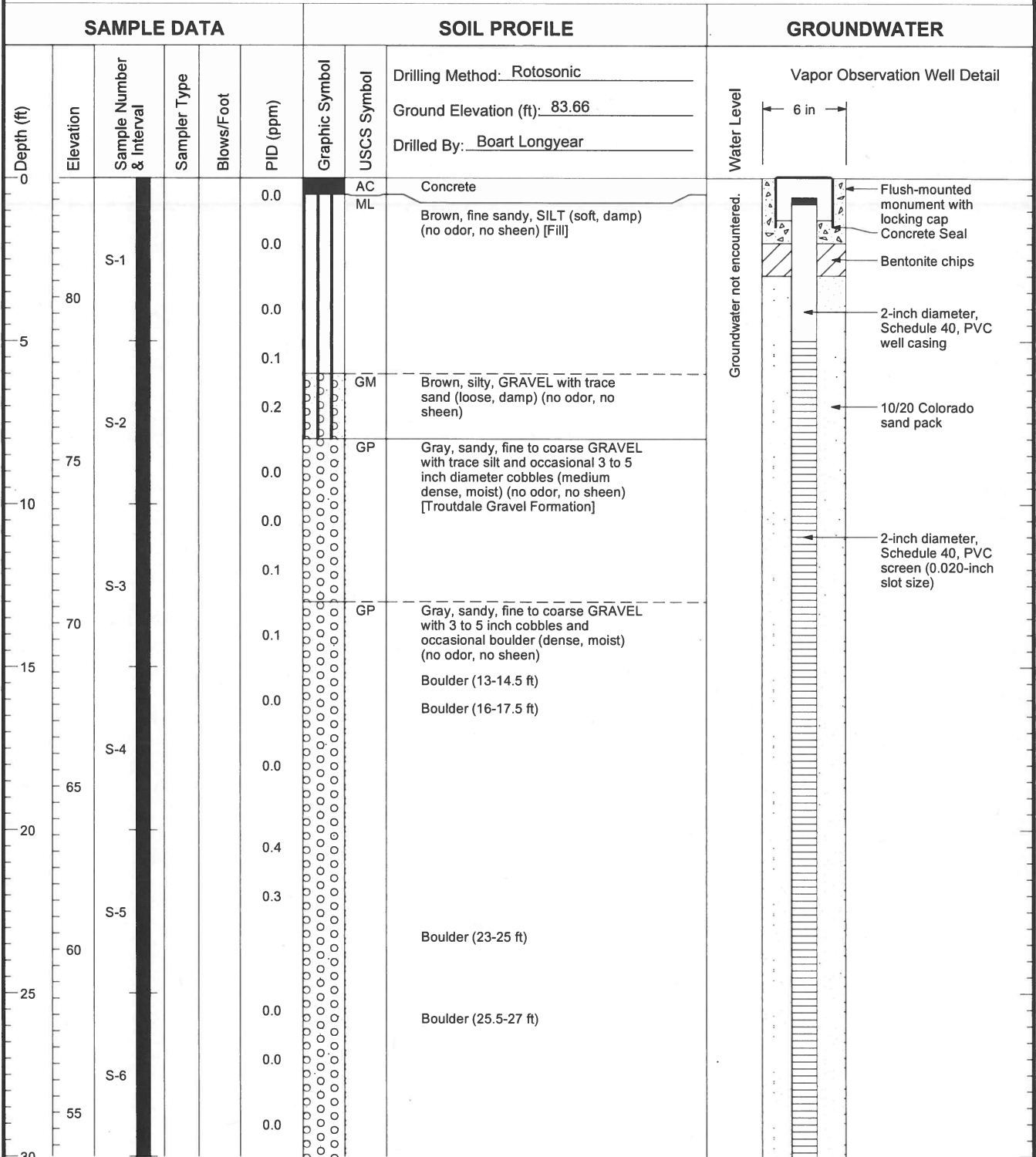

- Notes:
1. Stratigraphic contacts are based on field interpretations and are approximate.
 2. Reference to the text of this report is necessary for a proper understanding of subsurface conditions.
 3. Refer to "Soil Classification System and Key" figure for explanation of graphics and symbols.

25116.111 7/24/12 \PORTLAND01\GINT\PROJECTS\BOEING\025116.111.180.GPJ WELL LOG W/ ELEVATION



Boeing of Portland
Gresham, OR

Log of Vapor Observation Well VOW-18

Figure
A-15
(1 of 2)

VOW-18

SAMPLE DATA						SOIL PROFILE			GROUNDWATER	
Depth (ft)	Elevation	Sample Number & Interval	Sampler Type	Blows/Foot	PID (ppm)	Graphic Symbol	USCS Symbol	Drilling Method: <u>Rotosonic</u>	Water Level	Vapor Observation Well Detail
	30				0.0	GP	GP	Ground Elevation (ft): <u>83.66</u>		
	50	S-7			0.0	GP	GP	Drilled By: <u>Boart Longyear</u>		
35		S-8			0.0	GP	GP	Gray, sandy, fine to coarse GRAVEL with 3 to 5 inch cobbles and occasional boulder (dense, moist) (no odor, no sheen)	Groundwater not encountered.	
45		S-9			GP	GP	Brown to gray, sandy, fine to coarse GRAVEL with trace silt, 3 to 5 inch diameter cobbles and boulders (very dense, moist) (no odor, no sheen)			
40					GP	GP	Boulder (36-37 ft)			
40						GP	GP	Boulder (41-42 ft)		
45						GP	GP	Boulder (44-45 ft)		

Boring Completed 01/04/12
Total Depth of Boring = 45.0 ft.

Vapor Observation Well Completed 01/04/12
Total Depth of Vapor Observation Well = 44.3 ft.

- Notes:
1. Stratigraphic contacts are based on field interpretations and are approximate.
 2. Reference to the text of this report is necessary for a proper understanding of subsurface conditions.
 3. Refer to "Soil Classification System and Key" figure for explanation of graphics and symbols.

25116.111 7/24/12 \PORTLAND\1GINT\PROJECTS\BOEING\025116.111.180.GPJ - WELL LOG W/ ELEVATION



Boeing of Portland
Gresham, OR

Log of Vapor Observation Well VOW-18

Figure
A-15
(2 of 2)