



CITY OF THE DALLES, OREGON  
CONTRACT DOCUMENTS FOR:

# CONTRACT NO. 2025-010 WESTSIDE INTERCEPTOR-PHASE 2

---

CONTRACT DOCUMENTS  
VOLUME 1 - BIDDING REQUIREMENTS, CONTRACT FORMS,  
CONDITIONS OF THE CONTRACT,  
SPECIAL PROVISIONS, DRAWINGS

Project Manager:  
MICHAEL H. BOSSE  
CITY ENGINEER  
1215 West First Street  
The Dalles, OR 97058  
Telephone: (541) 296-5401

Bids must be submitted via email to [thedallesbids@ci.the-dalles.or.us](mailto:thedallesbids@ci.the-dalles.or.us) no later than 2:00pm Pacific Time on October 23, 2025. Note: Immediately following the electronic submission of a bid, bidders will receive confirmation that the bidder's email has been received. THE DUTY IS ON THE BIDDER TO ENSURE THAT THE REQUIRED BID DOCUMENTS ARE ATTACHED TO ANY EMAIL BEING SENT TO THE CITY IN RESPONSE TO THIS ADVERTISEMENT FOR BIDS.

Bid Opening will be via Zoom meeting. The meeting ID is 858 0212 1281. The Passcode is 068006.



# **TABLE OF CONTENTS**

## **VOLUME 1**

### **PART 1 - BID BOOKLET**

Bidder Checklist  
Invitation to Bidders  
Advertisement for Bids  
Conflict of Interest Guidelines  
Prequalification Form  
Conflict of Interest Disclosure  
Bid Form  
Bid Security  
Subcontractor Disclosure Form  
Certification of Non-Discrimination  
Non-Collusion Affidavit  
Responsibility Determination Form  
Notice of Award  
BOLI Prevailing Wage Rates Cover

### **PART 2 - CONTRACT BOOKLET**

Public Works Agreement  
Performance Bond  
Payment Bond  
Public Works Bond  
Certification of Workers' Compensation Coverage  
Notice to Proceed

### **PART 3 – SPECIAL PROVISIONS**

### **PART 4 – DRAWINGS**

## **DESCRIPTIONS OF PARTS OF CONTRACT WHICH ARE NOT BOUND HEREIN**

### **(1) Standard Specifications**

The “2025 City of The Dalles Standard Specifications for Construction”.

Copies of the 2025 City of The Dalles Standard Specifications for Construction may be obtained by contacting City of The Dalles Public Works Department (541) 296-5401 or downloaded at: [www.ci.the-dalles.or.us/engineering](http://www.ci.the-dalles.or.us/engineering)

### **(2) Prevailing Wage Rates**

The current “Prevailing Wage Rates for Public Works Contracts in Oregon” published by the Oregon Bureau of Labor and Industries.

Current copies of the “Prevailing Wage Rates for Public Works Contracts in Oregon” may be obtained by contacting Oregon Bureau of Labor and Industries (971) 673-0761 or downloaded at: [www.oregon.gov/boli/WHD/PWR/Pages/pwr\\_state.aspx](http://www.oregon.gov/boli/WHD/PWR/Pages/pwr_state.aspx)



PART 1

BID BOOKLET

WESTSIDE INTERCEPTOR-PHASE 2  
CONTRACT NO. 2025-010

# BIDDER'S CHECKLIST

- \_\_\_ Completed Prequalification and Conflict of Interest Forms and submit as directed in the Invitation to Bidders, by **October 16, 2025 at 4:00pm**

## ITEMS TO BE INCLUDED IN BID SUBMITTAL:

- \_\_\_ Completed Bid Form
- \_\_\_ Completed Affidavit of Noncollusion
- \_\_\_ Completed Bidder's Security
- \_\_\_ Completed Non-Discrimination Form
- \_\_\_ Signed addenda as may be issued during the bidding period
- \_\_\_ Completed Disclosure of First-Tier Subcontractors Form per Section 00120.40(f)- Submitted within two hours of Bid Opening via email to **thedallesbids@ci.the-dalles.or.us**.
- \_\_\_ Submit bid documents via email ONLY to **thedallesbids@ci.the-dalles.or.us** by **October 23, 2025 at 2:00pm**



**City of The Dalles**  
Department of Public Works  
1215 West 1<sup>st</sup> Street  
The Dalles, OR 97058

---

---

## INVITATION TO BIDDERS

September 2, 2025

### RE: WESTSIDE INTERCEPTOR-PHASE 2 CONTRACT NO. 2025-010

Dear Contractor,

The City of The Dalles, Department of Public Works, is requesting a bid from your firm to furnish all materials, labor and equipment necessary to install approximately 3,191 feet of 30" sanitary sewer pipe, 375 feet of 48" storm drain pipe and all manholes and appurtenances. All work will be conducted in accordance with the contract documents. If your price proposal is the lowest, you are judged a responsible and responsive bidder, the cost of the project is within budget limitations for each bid schedule, and award is authorized by the City Council you will receive a Notice of Award. Project is to be completed by June 12, 2026.

Electronic copies of the contract documents can be downloaded from the city's website at <http://www.thedalles.org/bids>. Bidder will be responsible for checking the website regularly for addendums and additional information for the project.

Bids shall be submitted to Amie Ell, City Clerk no later than **October 23, 2025 at 2:00pm Pacific Time via email to: [thedallesbids@ci.the-dalles.or.us](mailto:thedallesbids@ci.the-dalles.or.us)**, at which time the email account designated for bid receipt will be accessed. Bids shall not be sent to any other email addresses. Bid responses will be read aloud via a Zoom meeting. Zoom Meeting ID is 858 0212 1281 and use Passcode 068006. **Note:** Immediately following the electronic submission of a bid, bidders will receive confirmation that the bidder's email has been received. **THE DUTY IS ON THE BIDDER TO ENSURE THAT THE REQUIRED BID DOCUMENTS ARE ATTACHED TO ANY EMAIL BEING SENT TO THE CITY IN RESPONSE TO THIS ADVERTISEMENT FOR BIDS.**

Bidders must be prequalified in accordance with the laws of the State of Oregon. Prequalification forms shall be sent via email to [mbose@ci.the-dalles.or.us](mailto:mbose@ci.the-dalles.or.us) and must be received by **October 16, 2025 at 4:00pm Pacific Time.**

Questions, objections or comments regarding the project specifications must be submitted by email directed to Michael H. Bosse PE, Project Manager at [mbose@ci.the-dalles.or.us](mailto:mbose@ci.the-dalles.or.us). **They must be received no later than five (5) calendar days before the bid opening date.**

Sincerely,

CITY OF THE DALLES, OR

Michael H. Bosse  
City Engineer  
City of The Dalles

## **ADVERTISEMENT FOR BIDS**

### **Contract No. 2025-010**

The City of The Dalles ("City") is soliciting bids for the **WESTSIDE INTERCEPTOR-PHASE 2**. Bids must be submitted to Amie Ell, City Clerk no later than **October 23, 2025 at 2:00pm Pacific Time via email to: [thedallesbids@ci.the-dalles.or.us](mailto:thedallesbids@ci.the-dalles.or.us)**, at which time the email account designated for bid receipt will be accessed. Bids shall not be sent to any other email addresses. Bid responses will be read aloud via a Zoom meeting. The Zoom Meeting ID is 858 0212 1281 and use Passcode 068006. Note: Immediately following the electronic submission of a bid, bidders will receive confirmation that the bidder's email has been received. **THE DUTY IS ON THE BIDDER TO ENSURE THAT THE REQUIRED BID DOCUMENTS ARE ATTACHED TO ANY EMAIL BEING SENT TO THE CITY IN RESPONSE TO THIS ADVERTISEMENT FOR BIDS.**

The work to be performed shall consist of furnishing all materials, labor and equipment necessary to install approximately 3,191 feet of 30" sanitary sewer pipe, 375 feet of 48" storm drain pipe and all manholes and appurtenances. All work will be conducted in accordance with the contract documents. Bids must be submitted on the proposal form furnished by the City of The Dalles and shall bear the signature of the Bidder. The project is to be completed by June 12, 2026.

The Invitation to Bidders, Proposal Form, Contract, Specifications, Drawings and other Contract Documents will be posted to the City's website at **<http://www.thedalles.org/bids>**. Bidder will be responsible for checking the website regularly for addendums and additional information for the project. Questions regarding contract documents should be directed to Michael H. Bosse PE, Project Manager via email at: **[mbosse@ci.the-dalles.or.us](mailto:mbosse@ci.the-dalles.or.us)**

The City may reject any bid not in compliance with all prescribed public bidding procedures and requirements, and may reject for good cause any or all bids or bid schedules upon a finding of the City it is in the public interest to do so in accordance with ORS 279B.100. The City also reserves the right to waive any informality in connection with said bid or to postpone the award of the contract for sixty days. Each proposal must contain a statement as to whether the bidder is a resident bidder as defined by ORS 279A.120.

Bidders must be prequalified in accordance with the laws of the State of Oregon. Prequalification forms shall be sent via email to **[mbosse@ci.the-dalles.or.us](mailto:mbosse@ci.the-dalles.or.us)** and must be received by **October 16, 2025 at 4:00pm Pacific Time.**

Attention is particularly called to the requirements as to conditions of employment to be observed and minimum wage rates to be paid under the contract. No bid will be received or considered by the City of The Dalles unless the bid contains a statement by the Bidder as part of their bid that "Contractor agrees to be bound by and will comply with the provisions of 279C.838, 279C.840 or 40 U.S.C. 3141 to 3148."

No bid shall be considered by the public contracting agency unless the bidder is registered with the Construction Contractors Board or licensed by the State Landscape Contractors Board as required by ORS 671.530.

No bid may be withdrawn after the time set for the bid opening, or before the award of the Contract, unless award is delayed for a period exceeding 60 days.

CITY OF THE DALLES, OREGON  
Amie Ell, City Clerk

PUBLISHING DATE: September 2, 2025

**CITY OF THE DALLES CONFLICT OF  
INTEREST GUIDELINES (COI GUIDELINES)  
City of The Dalles (Agency)**

**ALL FIRMS** shall follow these COI Guidelines and submit the associated COI Disclosure Form when submitting any Proposal/Bid in response to an Agency Procurement that references these Guidelines or when entering into any Contract with Agency (and throughout the period during which the Proposal/Bid is open or the Contract is in effect) **REGARDLESS OF WHETHER THE FIRM HAS A CONFLICT OF INTEREST.**

**ALL FIRMS** shall also provide the COI Guidelines and associated COI Disclosure Form to all of its Subconsultants and Subcontractors at any tier of a Proposal/Bid or Contract and shall ensure that the Firm and each of its Subconsultants or Subcontractors make any disclosures required by these Guidelines or as required by a specific Procurement or Contract. The Agency will follow and apply these COI Guidelines when conducting specified Agency Procurements.

**1. Definitions**

The **definitions** that apply to these COI Guidelines and the Agency's COI Disclosure Form are at the end of this document.

**2. Required Disclosures**

**ALL FIRMS** shall indicate on their associated COI Disclosure Form whether:

**( note that "Public Official " includes all Agency employees):**

- a Firm or any of its Associates have any Apparent, Potential or Actual Conflicts Of Interest per these COI guidelines or per the criteria of any COI Form included as part of a Procurement or Contract;
- a Procurement or Contract document specifically requires submittal of a COI Disclosure Form (e.g., if the prospective Project includes preparation of an Environmental Impact Statement or Environmental Assessment, submittal of COI Disclosure Forms is always required.);
- a Firm has any changes to its staffing or organization (whether before or after entering into a Contract) that result in an Apparent, Potential or Actual Conflict Of Interest per these guidelines or per the criteria of any COI form associated with a particular Procurement or Contract. Any such changes shall be disclosed within 10 business days via submittal of a complete and signed COI Disclosure Form.
- The response to any of the following questions is "yes" (with respect to a Procurement or current Contract with Agency):
  1. Is any Associate of the Firm a former employee of Agency (within the last year)?
  2. Is any Associate of the Firm a Relative or Member of the Household of a current employee of Agency who had or may have a role in this Procurement, Authorization of the Contract, Contract administration, or oversight of the Contractor's performance?
  3. Does the Firm or any Associate of the Firm have an Actual, Apparent or Potential Conflict Of Interest ("Individual" or "Organizational") with regard to any member of an Agency Procurement evaluation or selection team?
  4. Did the Firm or any Associate of the Firm conduct prior work on the Project described in the Procurement, or participate in preparing any part of the Procurement or any documents or reports related to the Procurement or to which the Procurement refers?

5. Does the Firm or any Associate of the Firm have any past, present or currently planned interests which are an Actual, Apparent or Potential Conflict of Interest (“Individual” or “Organizational”) with respect to performing the work for Agency?
6. Has the Firm or an Associate of the Firm offered to a Public Official, or is the Firm aware of any Public Official that has solicited or received, directly or indirectly, any pledge or promise of employment or other benefit based on the understanding that the Public Official’s vote, official action or judgment would be influenced thereby?
7. Has (or will) the Firm or an Associate of the Firm provided a direct beneficial financial interest to any person within two years after the person ceased to hold a position as a Public Official who was involved in the Procurement or Authorization for the Contract, or is the Firm aware of any such person or Public Official who has or will receive a direct beneficial financial interest within the two year period?
8. Is the Firm aware of any current or former Public Official that has an Actual, Apparent or Potential Conflict Of Interest with respect to the Procurement or award of this Contract or performing the work for Agency?
9. Does the prospective Contract include development of an environmental assessment (EA) or environmental impact statement (EIS)?
10. If a Procurement is to obtain personal services for the purpose of administering, managing, monitoring, inspecting, evaluating compliance with or otherwise overseeing a public contract, is the Firm or an Associate or an Affiliate of the Firm a party to the subject public contract?
11. Has the Firm or any Associate of the Firm entered into personal services contract(s) with Agency for the purpose of advising or assisting in developing specifications, a scope or statement of work, an invitation to bid, a request for proposals or other solicitation documents and materials related to this procurement?

**A Firm shall incorporate in each required COI Disclosure Form any COI disclosure information provided by its staff and attach COI Disclosure Forms from each of its Subcontractors (that have required disclosures of conflicts or potential conflicts of interest), prior to such Firm performing any services under a Contract.**

Agency’s COI Disclosure Form is available on the Internet at the following Intranet site: [www.ci.the-dalles.or.us/engineering](http://www.ci.the-dalles.or.us/engineering) . Some Procurements may require submittal of a COI Disclosure Form (other than the standard form) that is specific to the Procurement.

### **3. Governing Standards**

Both Oregon and federal laws govern disclosure and management of conflicts of interest in transportation contracting processes. The disclosure requirements of these COI Guidelines apply to all Agency contracting activities {Architectural and Engineering (A&E) and non-A&E, public improvements, goods, and trade services} without regard to which particular federal or Oregon laws govern the activity. Agency also has a Code of Conduct Policy for conflicts of interest regarding the employment of former Agency employees, which is explained below.

#### **Agency Code of Conduct Policy Regarding Former Agency Employees**

When employees of firms which compete for or have Contracts with the Agency come to work for the Agency, and when Agency employees go to work for firms which compete for or have Contracts with the Agency, a Potential Conflict of Interest may exist.

Use of a former Agency employee by a Firm on the same, or substantially similar Procurement, for

which the employee performed a role or function for the Agency, unless mitigated to the satisfaction of the Agency, is prohibited for a period of one year following separation of employment with the Agency. Roles and functions of particular concern include drafting specifications or statements of work, reviewing or scoring a bid or proposal, authorizing service or assigning work, awarding a Contract, administering a Contract, or overseeing Contractor's performance. The Agency may determine that the role or Procurement is not substantially similar because of differences in location of the Project or work, because of the type and method of Procurement, or because the role performed was minor in nature such as a technical sufficiency review. Examples of mitigation that may, in appropriate situations, be acceptable to the Agency include separation of certain decision-making functions concerning the Project, not using the employee in preparation of proposals but allowing them to perform work on the Project, and not having the employee have direct contact with Agency staff formerly under his/her supervision.

For each Procurement, Firms shall disclose to Agency the identification of any employee(s) that had been employed by Agency within the last one-year period. Each Firm's disclosure shall include a signed statement by the former Agency employee of their proposed role for the Firm in the particular Procurement and any resulting Contract. Failure of a Firm to disclose such relationship or to remedy such potential violation will result in the rejection of the Firm's bid or cancellation of the Contract with the Agency as well as being grounds for cancellation of a Firm's prequalification or designation of a Firm as ineligible for future Procurements as not being a responsible bidder. (Also see below regarding the ORS 244.047 two-year ban on any direct beneficial interest.)

### **Oregon State Standards**

The current Oregon statutory framework, as generally applied, addresses conflicts of interest in public contracting by emphasizing the need for open and impartial Procurement methods and by prohibiting certain conflicts of interest involving public officials. The following statutes and administrative rules establish Oregon's general policies and the restrictions and prohibitions regarding conflicts of interest for public contracts and Public Officials:

- The policies of the Public Contracting Code (ORS 279A.015) encourage public contracting competition that supports openness and impartiality to the maximum extent possible, while recognizing that the nature of effective and meaningful competition depends upon the service being procured.
- According to ORS 279A.015(2) a sound and responsive public contracting system should instill public confidence through ethical and fair dealing, honesty and good faith on the part of government officials and those who do business with the government.
- ORS Chapter 244 prohibits conflicts of interest of Public Officials. Among the prohibitions are offering a public employee a pledge of future employment based on an understanding that the offer would influence the public employee's official action or judgment.
- ORS 244.047(2) and (3) provide the following:
  - (2) "Except as provided in subsection (3) of this section, a person may not, for two years after the person ceases to hold a position as a public official, have a direct beneficial financial interest in a public contract that was authorized by:
    - (a) The person acting in the capacity of a public official; or
    - (b) A board, commission, council, bureau, committee or other governing body of a public body of which the person was a member when the contract was authorized.
  - (3) Subsection (2) of this section does not apply to a person who was a member of a board,

commission, council, bureau, committee or other governing body of a public body when the contract was authorized, but who did not participate in the authorization of the contract.”

Agency’s administrative rules in OAR 731 Division 70 establish conflict of interest rules for the Oregon Innovative Partnership Program. The Oregon Government Ethics Commission also has administrative rules for public officials in OAR 199 Division 5.

- ORS 279.C.307 includes the following:

(1) “Except as provided in subsection (2) of this section, a contracting agency that procures personal services for the purpose of administering, managing, monitoring, inspecting, evaluating compliance with or otherwise overseeing a public contract that is subject to this chapter may not:

(a) Procure the personal services from a contractor or an affiliate of a contractor who is a party to the public contract that is subject to administration, management, monitoring, inspection, evaluation or oversight by means of the personal services; or

(b) Procure the personal services through the public contract that is subject to administration, management, monitoring, inspection, evaluation or oversight by means of the personal services.

(2) Subsection (1) of this section does not apply to a procurement that qualifies as a Construction Manager/General Contractor procurement or a Design-Build procurement, both as defined in OAR 125-249-0610 or 137-049-0610.

(3) As used in this section, “affiliate” means a person that, directly or indirectly through one or more intermediaries, controls, is controlled by or is under common control with the contractor described in subsection (1)(a) of this section.”

- ORS 279B includes the following per 2012 Senate Bill 1518, Section 2 (Oregon Laws 2012, Chapter 53):

(1) Except as provided in subsection (2) of this section, a state contracting agency that procures personal services for the purpose of advising or assisting the state contracting agency in developing specifications, a scope or statement of work, an invitation to bid, a request for proposals or other solicitation documents and materials related to a procurement may not accept from the contractor, or an affiliate of the contractor, that advised or assisted the state contracting agency a bid or proposal for the goods or services described, specified or identified in the solicitation documents or materials if a reasonable person would believe that, by giving the advice or assistance, the contractor or affiliate would have or would appear to have an advantage in obtaining the public contract that is the subject of the solicitation.

(2)(a) If a state contracting agency anticipates that the state contracting agency will or must seek advice or assistance of the type described in subsection (1) of this section from a contractor that is also engaged in providing goods or services that will be described or identified in the solicitation documents and materials that result from the advice or assistance, and the state contracting agency wishes to accept a bid or proposal from the contractor, the state contracting agency, before awarding a contract for the advice or assistance, shall apply to the Director of the Oregon Department of Administrative Services for an exception to the prohibition set forth in subsection (1) of this section.

(b) The state contracting agency in the application for the exception shall include findings and justifications, along with sufficient facts to support the findings and justifications, that will enable the director to make an independent judgment as to whether:

(A) The state contracting agency needs advice or assistance from a contractor to develop the solicitation documents and materials described in subsection (1) of this section;

(B) Accepting a bid or proposal from the contractor that gives the advice or assistance is the only practicable way in which the state contracting agency can conduct the procurement successfully; and

(C) Approving the exception:

(i) Is unlikely to encourage favoritism in awarding public contracts or to substantially diminish competition for public contracts; and

(ii)(I) Is reasonably expected to result in substantial cost savings to the state contracting agency or the public; or

(II) Otherwise substantially promotes the public interest in a manner that could not be practicably realized by complying with the prohibition described in subsection (1) of this section.

(c)(A) If the director approves the state contracting agency's application, the director shall prepare written findings and justifications for the approval. The state contracting agency's findings, justifications and facts and the director's findings, justifications and approval are public records that are subject to disclosure as provided in ORS 192.410 to 192.505.

(B) If the director disapproves the state contracting agency's application, the director shall state the director's reasons for the disapproval in a written notice to the state contracting agency and shall indicate whether the disapproval extends only to the state contracting agency's acceptance of a bid or proposal from a contractor that gives advice or assistance in preparing solicitation documents and other materials or whether the director also disagrees with the state contracting agency's stated need for advice or assistance from a contractor.

(C) The director's approval or disapproval is final.

(3) As used in this section, "affiliate" means a person that, directly or indirectly through one or more intermediaries, controls, is controlled by or is under common control with a contractor described in this section.

(4) This section does not apply to the Secretary of State or the State Treasurer.

- [OAR 137-048-0130](#)(8), (9) and (10) provides:

"(8) As required by ORS 279C.307, pertaining to requirements to ensure the objectivity and independence of providers of certain Personal Services which are procured under ORS chapter 279C, Contracting Agencies may not:

(a) Procure the Personal Services identified in ORS 279C.307 from a Contractor or an affiliate of a Contractor who is a party to the Public Contract that is subject to administration, management, monitoring, inspection, evaluation or oversight by means of the Personal Services; or

(b) Procure the Personal Services identified in ORS 279C.307 through the Public Contract that is subject to administration, management, monitoring, inspection, evaluation or oversight by means of the Personal Services.

(9) The requirements of ORS 279C.307 and section (8) of this rule apply in the following circumstances, except as provided in section (10) of this rule:

(a) A Contracting Agency requires the Procurement of Personal Services for the purpose of administering, managing, monitoring, inspecting, evaluating compliance with or otherwise overseeing a Public Contract or performance under a Public Contract that is subject to ORS chapter 279C. A Public Contract that is “subject to ORS chapter 279C” includes a Public Contract for Architectural, Engineering, Photogrammetric Mapping, Transportation Planning or Land Surveying Services, a Public Contract for Related Services or a Public Contract for construction services under ORS chapter 279C.

(b) The Procurements of Personal Services subject to the restrictions of ORS 279C.307 include, but are not limited to, the following:

(A) Procurements for Architectural, Engineering, Photogrammetric Mapping, Transportation Planning or Land Surveying Services, which involve overseeing or monitoring the performance of a construction Contractor under a Public Contract for construction services subject to ORS chapter 279C;

(B) Procurements for commissioning services, which involve monitoring, inspecting, evaluating or otherwise overseeing the performance of a Contractor providing Architectural, Engineering, Photogrammetric Mapping, Transportation Planning or Land Surveying Services or the performance of a construction Contractor under a Public Contract for construction services subject to ORS chapter 279C;

(C) Procurements for project management services, which involve administration, management, monitoring, inspecting, evaluating compliance with or otherwise overseeing the performance of a Contractor providing Architectural, Engineering, Photogrammetric Mapping, Transportation Planning or Land Surveying Services, construction services subject to ORS chapter 279C, commissioning services or other Related Services for a Project;

(D) Procurements for special inspections and testing services, which involve inspecting, testing or otherwise overseeing the performance of a construction Contractor under a Public Contract for construction services subject to ORS chapter 279C; and

(E) Procurements for other Related Services or Personal Services, which involve administering, managing, monitoring, inspecting, evaluating compliance with or otherwise overseeing the Public Contracts described in Section (9)(a) of this rule.

(10) The restrictions of ORS 279C.307 do not apply in the following circumstances, except as further specified below:

(a) To a Contracting Agency’s Procurement of both design services and construction services through a single “Design-Build” Procurement, as that term is defined in OAR 137-049-0610. Such a Design-Build Procurement includes a Procurement under an Energy Savings Performance Contract, as defined in ORS 279A.010. Provided, however, the restrictions of ORS 279C.307 do apply to a Contracting Agency’s Procurement of Personal Services for the purpose of administering, managing, monitoring, inspecting, evaluating compliance with or otherwise overseeing a Design-Build Contract or performance under such a Contract resulting

from a Design-Build Procurement; and

(b) To a Contracting Agency's Procurement of both pre-construction services and construction services through a single "Construction Manager/General Contractor" Procurement, as defined in OAR 137-049-0610. Provided, however, the restrictions of ORS 279C.307 do apply to a Contracting Agency's Procurement of Personal Services for the purpose of administering, managing, monitoring, inspecting, evaluating compliance with or otherwise overseeing a Construction Manager/General Contractor Contract or performance under such a Contract resulting from a Construction Manager/General Contractor Procurement."

Agency's COI Guidelines embody the intent of encouraging competition through openness, impartiality, and public disclosure of relevant information (and the avoidance of conflicts of interest) as described in ORS 279A.015, ORS Chapter 244, and Agency's Code of Conduct Policy.

The two-year prohibition against a Public Official having a direct beneficial financial interest in a public contract as provided in ORS 244.047 would generally preclude the person from working under the public contract and from representing the Firm in dealings with the public agency for whom the person had worked. Sharing in the general profits of the Firm (such as a year-end bonus for overall corporate profits) is likely not a direct beneficial financial interest, however, a bonus or other compensation paid just on the basis of the public contract would be subject to the prohibition.

**Federal Standards— Procurements Related To Design-Build and Design-Bid-Build**

Pursuant to 23 USC § 112(b)(3), the FHWA has promulgated administrative rules that affect federally funded Design-Build procurements and related procurements. These rules, which are in Chapter 23 of the CFR Part 636, are used as the basis for Agency's guidelines on the subject and specifically regulate both Organizational and Individual Conflicts Of Interest. Agency's COI Guidelines incorporate a number of concepts from these federal provisions.

The main rule on Organizational Conflicts Of Interest in Design-Build transactions is 23 CFR §636.116. This rule affects not only Design-Build procurements, but also "any contract for engineering services, inspection or technical support in the administration of the Design-Build contract." Following is a summary of this federal rule (Agency's COI Guidelines apply this rule to design-bid-build and non-A&E activities as well):

Generally, a consultant who assists the state in preparing a Request for Proposals (RFP) document may not, subsequently, propose in response to the RFP. However, the state may determine that the consultant does not have a conflict of interest for a subsequent Procurement, if the consultant furnished only "low-level" documents that were incorporated into the RFP and made available to all offerors, and did not assist the state in the development of instructions to offerors or evaluation criteria for the RFP.

These Design-Build regulations also apply to "improper business practices and personal conflicts of interest" of the Agency's selection team members. 23 CFR § 636.117 indicates that Federal Acquisition Regulations ("FARs"---specifically 48 CFR Part 3, Improper Business Practices and Personal Conflicts of Interest) will apply to the state's selection team members in the absence of relevant state laws and procedures. These regulations require government business to be "above reproach," conducted "with complete impartiality and with preferential treatment for none" and with "the highest degree of public trust and an impeccable standard of conduct" to avoid "even the appearance of a conflict of interest."

In design-bid-build transactions, where engineering services are procured separately from the construction services, ordinarily the consulting Firm providing the engineering services is not eligible

to bid on the construction work for the Project.

No Firm or any Associate of a Firm in connection with a Transportation Project shall have, directly or indirectly, any interest, other than his employment or retention by a State or other governmental instrumentality, in any Contract in connection with such Project. No firm or an Associate of a Firm shall have, directly or indirectly, any interest in any real property acquired or to be acquired for a Project unless such interest is openly disclosed upon the records of Agency and such Firm or Associate has not participated and will not participate in such acquisition for and in behalf of Agency (see 23 CFR § 1.33).

### **Federal Standards - National Environmental Policy Act (NEPA)**

No Firm preparing or providing environmental analysis or impact documents relating to a Project, including draft and final Environmental Assessments (EA) or Environmental Impact Statements (EIS) may have a financial or other interest in the outcome of the Project. A financial or other interest in the outcome of the Project includes any known benefits other than general enhancement of professional reputation, and includes any agreement, enforceable promise, guarantee or expectation of future work on the Project as well as any indirect benefit the Firm is aware of such as if the Project would aid proposals sponsored by the Firm's other clients. Compliance with [40 C.F.R. 1506.5\(c\)](#) is required, which includes the requirement for a conflict of interest disclosure statement from each Firm establishing that the Firm does not have a financial or other interest in the Project.

#### **4. COI Considerations Related to Previous Work on Projects**

No Firm that has previously performed services on behalf of Agency for a Project may be a Proposer or participate as an equity owner, team member, Subcontractor of or to a Proposer on the Project, or have a financial interest in any of the foregoing entities with respect to the Project, unless Agency is satisfied in its sole discretion that:

- (a) such services were completed prior to initiation of the Procurement for the Project (exceptions may apply for NEPA services on a case-by-case evaluation of the project specifics against the applicable CFRs),
- (b) such services included only Low Level Documents and did not include development of instructions to offerors or evaluation criteria for the RFP,
- (c) such services did not provide the Firm with access to or knowledge of Agency confidential or inside information that could provide an unfair competitive advantage with respect to the Procurement,
- (d) the prior Contract and information provided to the Firm in the performance of its services are either irrelevant to the Procurement or are available on an equal and timely basis to all Proposers,
- (e) the work product from the Firm incorporated into or relevant to the Procurement is available through Public Disclosure on an equal and timely basis to all Proposers, and
- (f) any environmental documents prepared by the Firm have been determined to be objective, and that the Agency demonstrated independent decision-making authority during the environmental process.

In such instances where Agency is satisfied in the manner described above, Agency may still, in its sole discretion, restrict the scope of Procurement services for which the Firm shall be eligible to perform in order to further the intent and goals of these COI Guidelines.

Public Disclosure of services or products is an important consideration in determining if an Organizational Conflict Of Interest exists. All COI Disclosure Forms will be considered public records.

## **5. COI Disclosure Process**

A Firm shall certify its conformance with these COI Guidelines at the time of submitting a proposal to Agency or entering into a Contract with Agency. If submittal of COI Disclosure Form(s) is required per these COI Guidelines or a specific Procurement or Contract, a Firm shall represent the correctness of a completed COI Disclosure Form. If a Firm has any changes to its staffing or organization (whether before or after entering a Contract) that result in an Actual, Apparent or Potential Conflict Of Interest (Individual or Organizational) per these COI Guidelines or per the criteria of any COI form associated with a particular Procurement or Contract, any such changes shall be disclosed within 10 business days via submittal of a Correct and signed COI Disclosure Form.

A Firm shall assure that any COI Disclosure Form it submits includes any information required to be disclosed by its Subcontractors and other Associates, on behalf of the Firm. A Firm may submit either the Subcontractors' separate COI Disclosure Forms or incorporate Subcontractor information into its own COI Disclosure Form. The disclosure required with the proposal applies to the prime and all proposed Subcontractors that are identified or anticipated at the time of proposal submission.

The identification, assessment, and management of Actual or Potential Conflicts Of Interest are joint tasks among Agency, the Firm and the Firm's team. A Firm must work together with Agency in an atmosphere of candor and accountability during the period of negotiation or performance of the Contract with Agency. Agency makes the final determination as to the adequacy of any COI disclosures or COI management plan offered by the Firm.

Agency's COI determination is based on a number of factors such as:

- ✓ Situational Facts – description of the situation and all known facts specific to the actual or perceived COI
- ✓ Type of Work - specific product or service and Contract(s) involved
- ✓ Relationship to Management - specific interactions with Agency decision-makers
- ✓ Public Disclosure - timing and availability of product or service

The specific facts disclosed in any COI situation will be unique to that situation. Therefore, the decisions and conclusions reached in one situation may or may not be directly applicable to another. For example, the definition of "low-level" documents does not isolate a Firm producing them from a potential COI situation. The ultimate determination will take into account the other factors described above.

## **6. Examples of Conflict of Interest Situations**

Agency offers the following examples to better illustrate conflict of interest situations that may arise during the course of the performance of a Personal Services Contract or a Price Agreement and any WOC entered into between Agency and a Firm, or during any Agency Procurement process, in order to provide guidance to Firms as they determine if their specific situations warrant disclosure, evaluation, and management.

1. A Design-Build solicitation requires the responding teams to propose how to manage site features that were uncovered by a geotechnical engineering Firm. The Firm's reports to Agency on the Project are available to the public. A multi-specialty engineering Firm that is the parent company of the geotechnical engineering Firm submits a proposal to design

the overall Project. Depending on the particular mitigating facts, Agency might determine in writing that the multi-specialty engineering Firm is eligible to propose.

2. Agency seeks comprehensive project management services for a series of Transportation Projects. One of the proposing Firms employed a senior official from Agency who played a significant role in providing direction for the solicitation, six months ago. Agency initially assesses this situation as a potential Organizational Conflict Of Interest and provides information to potential Proposers of this assessment through an addendum to the RFP. In its proposal, the Proposer provides mitigating information and written assurances that this individual works in an area of the company that will not be working on their program management proposal and that the individual will be isolated inside the company from any information associated with the program, will not be lobbying Agency, will not engage in any activities that would violate the Agency Code of Conduct Policy for the prescribed one year period, and for a period of two years will not have a direct beneficial interest in the contract. Depending on the particular facts, Agency might determine that, while the proposing Firm has a potential Organizational Conflict Of Interest, that conflict has been adequately mitigated and the Firm will not be disqualified from submitting a proposal.
3. Agency issues an RFP for design and oversight of an intelligent system to collect bridge tolls. The RFP provides that companies having a financial interest in the relevant telecommunications hardware will be excluded from bidding. A company under common ownership with a major electronics manufacturer desires to bid. Agency initially assesses this situation as an Organizational Conflict Of Interest, because it cannot know in advance whether the hardware products of this electronics manufacturer would be used in the Project, and Agency informs potential Proposers of its concern related to this type of conflict via addendum to the RFP. In its proposal, the company offers no mitigating facts or organizational plans that address Agency's concerns about the conflict. Depending on the particular facts, Agency determines that the company has an actual conflict of interest.
4. Agency seeks advice of an industry advisory committee to formulate the specifications for an information technology (IT) RFP. An IT Firm that participated in the advisory committee wishes to submit a proposal in response to the RFP. Depending on the particular facts, Agency might determine that the role of the Firm was to represent the industry in the context of a public meeting where other Firms were invited to submit comments, and that the Firm therefore does not have an Organizational Conflict Of Interest.
5. Agency contracts with an A&E Firm to develop "low-level" documents prior to establishing a schedule for a RFP in which the "low level" documents, still under development, will be used by prospective Proposers. The A&E Firm has attended the pre-proposal meeting and wishes to propose on the RFP. Agency determines that the company has a potential Organizational Conflict Of Interest because of the fact that the low-level documents have not been made public and the Firm will still be developing the documents during the solicitation. The company then mitigates the potential conflict of interest by suspending development of new reports during the open period of the solicitation and making all data and information sources available on an Agency website prior to the RFP release. Agency determines that the potential conflict has been adequately managed and the Firm will not be disqualified from submitting a proposal or being part of the proposing team.
6. Agency contracts with a consulting Firm to assist Agency in the development of an RFP and sample Contract for a Design-Build Procurement for construction of certain Transportation Projects. The Firm has close contact with Agency decision-makers in the development of the evaluation criteria for the RFP and the proposed Contract terms, and that information is shared throughout the Firm with all management and technical personnel. The Firm will not be able to submit a proposal in the design-build Procurement, or participate as a team member with a Firm submitting a proposal in response to the RFP.
7. Agency seeks comprehensive program management services for a series of Transportation Projects. Prior to release of the RFP, Agency shared its interpretation of

the applicable conflict of interest requirements with the industry. One of the proposing Firms has a related entity with a planned interest in future design-build construction work related to the transportation program. The COI Disclosure Form does not clearly state whether the related entity is a subsidiary, major partner, Subcontractor, or affiliate of a Subcontractor. The proposing Firm describes its intent to restrict the flow of information concerning construction Projects to the related entity and thereby to its affiliate construction company but does not clarify how much information will be shared between the principal and its Subcontractors and affiliates or the controls placed on the principal-Subcontractor-affiliate relationship. Furthermore, the proposing Firm has provided mitigation information, indicating that the related entity will not participate in providing services under the program management Contract (i.e., design, source selection, award of Contract, etc.). Agency may conclude the proposing Firm does not have a conflict of interest that detracts from its eligibility for the program management award. Agency may determine that the related entity has a conflict of interest in future design-build construction work related to the bridge repair and replacement program that has not been adequately mitigated by the measures and information provided by the proposing Firm. As a result, if the proposing Firm is awarded the program management Contract, the related construction company will be ineligible for construction work under the program. This determination will depend upon the precise relationship between the related entity and the Proposer.

8. Completion of a project may encourage construction of a shopping center or industrial park from which a Firm stands to benefit. If a Firm is aware that it has such an interest in the decision on the proposal, it will be disqualified from preparing an EIS to preserve the objectivity and integrity of the NEPA process.
9. Agency issues an RFP for A&E services to prepare plans, specifications, and estimate (PS&E) to replace a bridge. The PS&E will be completed as part of a design-bid-build process. One of the A&E firms proposing on the design services owns XYZ Inc., a subsidiary that provides program management services to Agency under a separate contract. Agency's intent, as advertised in the RFP, is to use XYZ Inc. for administration and oversight of the A&E design services for the bridge replacement project. The A&E firm that is the parent of XYZ Inc. would be ineligible for award of the A&E design contract.
10. Agency issues an ITB for construction services to replace a bridge. The replacement is being done using the design-bid-build process. One of the construction firms bidding on the public improvement project owns XYZ Inc., a subsidiary that provides construction contract administration and inspection services to Agency under a separate contract. Agency's intent, as advertised in the ITB, is to use XYZ Inc. for administration and inspection of the bridge replacement project. The construction firm that is the parent of XYZ Inc. would be ineligible for award of the construction contract.

## Definitions

The following definitions apply to these COI Guidelines and the Agency's COI Disclosure Form:

**“Actual Conflict Of Interest”** means that an individual or Firm is unable to render impartial assistance or advice to Agency, has impaired objectivity in performing the Project work, or has an unfair competitive advantage. For purposes of ORS Chapter 244, and as defined in ORS 244.020(1), “Actual Conflict of Interest” means any action or any decision or recommendation by a person acting in a capacity as a public official, the effect of which *would be* to the private pecuniary benefit or detriment of the person or the person's relative or any business with which the person or a relative of the person is associated unless the pecuniary benefit or detriment arises out of the circumstances described in the ORS Chapter 244 definition for “Potential Conflict of Interest” (see definition below).

**“Affiliate”** (of the Firm) means a person or entity that, directly or indirectly through one or more intermediaries, controls, is controlled by or is under common control of the Firm.

**“Apparent Conflict Of Interest”** means that an individual or Firm may reasonably be perceived to have an Actual Conflict of Interest or a Potential Conflict Of Interest.

**“Associate”** (of the Firm) means an employee, executive, director, key project personnel, consultant, contractor or Subcontractor, or any immediate family member of the foregoing.

**“Authorization”** (of the Contract). A public contract is authorized by a Public Official if the Public Official performed a significant role in the selection of a Firm or the execution of the Contract. A *significant role includes* recommending approval or signing of the Contract, including serving as a reference, recommending selection or serving on a selection committee or team, or having the final authorizing authority for the Contract.

**“Bidder”** means a legally operating business entity submitting a bid in response to a Procurement.

**“Conflict Of Interest”** or **“COI”** means an Individual Conflict Of Interest or Organizational Conflict Of Interest and includes an Actual, Potential, or Apparent Conflict Of Interest.

**“COI Disclosure Form”** means a manually signed disclosure of any Actual Conflict Of Interest, Apparent Conflict Of Interest or Potential Conflict Of Interest documented in the form of Agency’s COI Disclosure Form.

**“Correct ”** means, in the context of determining the accuracy of a COI Disclosure Form, that the form, in all material respects, is complete, accurate, not misleading, and does not omit any material information.

**“Contract”** means an Agreement to Agree (ATA), Price Agreement (PA), Work Order Contract (WOC), Purchase Order (PO), or any other contract with Agency.

**“Firm”** means a Proposer or Bidder under a Procurement, a consultant or contractor under a Contract, or a Subcontractor at any tier of a Proposer, consultant, or contractor, and any partner or member of any of the foregoing. A Firm includes all persons, individual or corporate, without regard to form of legal entity, and any partner or member of any of the foregoing.

**“Member of the Household”** (of the Public Official) means any person who resides with the Public Official.

**“Individual Conflict Of Interest”** means that an individual has a conflict of interest because of a financial interest, gift, or other activities or relationships with other persons including but not limited to individuals with whom the individual has business, familial or household relationships.

**“Interest”** (in the context of a conflict of interest) means a direct or indirect interest and includes a personal as well as financial interest.

**“Low-Level Document”** means A&E, non-A&E and IT program or Project related documents which provide a basic understanding of a specific aspect of the program or Project. As referred to in 23CFR 636.116 with regard to A&E and related services, “the role of the consultant or subconsultant was limited to provision of preliminary design, reports, or similar “low-level” documents that will be incorporated into the RFP, and did not include assistance in development of instructions to offerors or evaluation criteria”.

**“Organizational Conflict Of Interest”** means that a relationship or situation exists whereby a Firm or any of its Associates has past, present, or currently planned interests or activities that either directly or indirectly (through a client, contractual, financial, organizational or other

relationship) may relate to the work to be performed under the proposed Contract with Agency and which (a) diminish the Firm's or an Associate's capacity to give impartial, technically sound, objective assistance or advice, (b) may impair the Firm's or an Associate's objectivity in performing the Contract, (c) may impair Agency's objectivity in oversight of the Contractor's performance, or (d) may result in an unfair competitive advantage. It does not include the normal flow of benefits from the performance of the Contract.

**“Potential Conflict Of Interest”** means that an individual or Firm, as a result of current plans, may reasonably be expected to have an actual conflict of interest. For purposes of ORS Chapter 244, and as defined in ORS 244.020(11), “Potential Conflict of Interest” means any action or any decision or recommendation by a person acting in a capacity as a public official, the effect of which *could be* to the private pecuniary benefit or detriment of the person or the person's relative, or a business with which the person or the person's relative is associated, unless the pecuniary benefit or detriment arises out of the following: (a) an interest or membership in a particular business, industry, occupation or other class required by law as a prerequisite to the holding by the person of the office or position.; (b) any action in the person's official capacity which would affect, to the same degree, a class consisting of all inhabitants of the state or a smaller class consisting of an industry, occupation or other group including one of which or in which the person, or the person's relative or business with which the person or the person's relative is associated, is a member or is engaged; or (c) membership in or membership on the board of directors of a nonprofit corporation that is tax-exempt under section 501(c) of the Internal Revenue Code.

**“COI Guidelines”** refers to this document and all references herein.

**“Procurement”** means a Request for Proposals (RFP), Request for Qualifications (RFQ), Request for Information (RFI), Invitation to Bid (ITB), or any other form of solicitation or Procurement by Agency.

**“Proposal”** means a bid, proposal, or other submission appropriate to a Procurement.

**“Proposer”** means a legally operating business entity submitting a Proposal in response to a Procurement.

**“Public Disclosure”** means the work product or service (in connection with the preparation of a Procurement) is available for public review and analysis for a reasonable amount of time, typically at least thirty (30) calendar days.

**“Public Official”** means any person who is serving the State of Oregon or any of its political subdivisions or any other public body as defined in ORS 174.109 as an elected official, appointed official, employee, agent or otherwise, irrespective of whether the person is compensated for the services. (All Agency employees are Public Officials.)

**“Relative”** (of a Public Official) means:

- the Public Official's spouse or domestic partner;
- the children, siblings, spouses of siblings or parents of the Public Official or the Public Official's spouse; or
- any individual for whom the Public Official has a legal support obligation or for whom the Public Official provides benefits arising from the Public Official's public employment or from whom the Public Official receives benefits arising from that individual's employment.

**“Subcontractor”** means a subcontractor or subconsultant at any tier.

**“Transportation Project”** or **“Project”** means any proposed or existing undertaking pertaining to highways, bridges, motor carriers, motor vehicles, public transit, rail, transportation safety, information systems, and such other programs related to transportation that are assigned to Agency

under applicable law.

**PREQUALIFICATION FORM**

**WESTSIDE INTERCEPTOR-PHASE 2  
CONTRACT No. 2025-010**

**1) BIDDER'S GENERAL INFORMATION**

Contractor's Name: \_\_\_\_\_

Doing business as: \_\_\_\_\_  
(An Individual, Partnership, Corporation, LLC)

Oregon Secretary of State Corp. Div. Registry No. \_\_\_\_\_

Address 1: \_\_\_\_\_

Address 2: \_\_\_\_\_

Phone: \_\_\_\_\_ Fax: \_\_\_\_\_

Application prepared by: \_\_\_\_\_

Preparer's Email: \_\_\_\_\_

Oregon Construction Contractors Board No. (CCB) \_\_\_\_\_

Other State License No. \_\_\_\_\_

**2) BONDING**

Surety Company: \_\_\_\_\_

Agent Name: \_\_\_\_\_

Address 1: \_\_\_\_\_

Address 2: \_\_\_\_\_

Phone: \_\_\_\_\_ Fax: \_\_\_\_\_

Bonding Capacity: Per Project \$ \_\_\_\_\_ Aggregate \$ \_\_\_\_\_

**3) WORK EXPERIENCE**

A. How many years has your firm been in business under its present name?

As a prime contractor? \_\_\_\_\_ As a subcontractor? \_\_\_\_\_

B. How many years' experience in construction work has your firm had?

As a prime contractor? \_\_\_\_\_ As a subcontractor? \_\_\_\_\_

C. **ATTACH TO THIS FORM** the experience resume of the person who will be designated on-site construction manager. On-site manager or their designee shall have ODOT ADA Certification for Contractors or approved equal. Provide copy of certifications with resume.

D. List three (3) projects completed as of recent date involving work of a similar type and complexity (attach sheets as needed):

PROJECT #1

Owner Name, Project Name	Contract Price	Date of Completion
Contact Name, Address and Phone of Owner	Describe Work Performed	

PROJECT #2

Owner Name, Project Name	Contract Price	Date of Completion
Contact Name, Address and Phone of Owner	Describe Work Performed	

PROJECT #3

Owner Name, Project Name	Contract Price	Date of Completion
Contact Name, Address and Phone of Owner	Describe Work Performed	

4) **SUPPLEMENTAL QUESTIONS** – Attach written explanations as appropriate

- A. Has your company changed its name during the past 5 years? Yes \_\_\_ No \_\_\_  
If yes, provide your company's former name: \_\_\_\_\_
- B. Has your company ever been denied prequalification by any state, local or federal agency in this or any other state?  
Yes \_\_\_ No \_\_\_ **if yes, please attach an explanation**
- C. Has your company ever failed to complete a state, local or federal public improvement contract?  
Yes \_\_\_ No \_\_\_ **if yes, please attach an explanation**
- D. Has your company had any claims placed against one of your payment bonds or performance bonds in the past 5 years?  
Yes \_\_\_ No \_\_\_ **if yes, please attach an explanation**
- E. Have you or your company ever been debarred from bidding on contracts by any state, local or federal agency in this or any other state?  
Yes \_\_\_ No \_\_\_ **if yes, please attach an explanation**
- F. Has your company filed for bankruptcy in the past 5 years?  
Yes \_\_\_ No \_\_\_ **if yes, please attach an explanation**
- G. Has your company had any willful OSHA violations in the past 5 years?  
Yes \_\_\_ No \_\_\_ **if yes, please attach an explanation**
- H. Within the last 5 years has the applicant, or any parent, subsidiary or affiliate, failed to complete a state, local or federal public improvement (works) contract?  
Yes \_\_\_ No \_\_\_ **if yes, please attach an explanation**
- I. Within the last 5 years has the applicant, or any parent, subsidiary or affiliate, been found in breach of a local, state or federal contract?  
Yes \_\_\_ No \_\_\_ **if yes, please attach an explanation**
- J. Within the last 5 years have you, your company or any officers, agents or employees of your company been found to have violated any State or Federal prevailing wage statute, regulation (including the federal Davis-Bacon and Related Acts and ORS 279C.830 et. seq.) in any Final Order of the Oregon

Bureau of Labor and Industries or the US Department of Labor, or by any court of competent jurisdiction?

Yes \_\_\_\_ No \_\_\_\_

**If yes, provide copies of the final order or judgment and explain in detail the following:**

- the circumstances behind any violation, including the amount not paid
- whether the amounts have now been paid
- the reasons for the violation
- all efforts undertaken to ensure that future violations will not occur

**K.** Does your firm have available the appropriate financial, material, equipment, facility and personnel resources and expertise, or ability to obtain the resources and expertise, necessary to demonstrate the capability of the firm to meet all contractual responsibilities?

Yes \_\_\_\_ No \_\_\_\_ **if yes, please provide supporting documentation**

**L.** Is your firm experiencing financial distress or having difficulty securing financing?

Yes \_\_\_\_ No \_\_\_\_

**M.** Does your firm have sufficient cash flow to fund day-to-day operations throughout the proposed contract period?

Yes \_\_\_\_ No \_\_\_\_

**N.** Within the last 5 years, has your firm completed previous contracts of a similar nature with a satisfactory record of performance? [For purposes of this question, a satisfactory record of performance means that to the extent that the costs associated with and time available to perform a previous contract remained within your firm's control, your firm stayed within the time and budget allotted for the procurement and otherwise performed the contract in a satisfactory manner.]

Yes \_\_\_\_ No \_\_\_\_ **if no, please attach an explanation**

**O.** Does your firm have all required licenses, insurance and/or registrations, if any, and is the firm legally authorized to do business in the State of Oregon?

Yes \_\_\_\_ No \_\_\_\_ **if no, please attach an explanation**

**P.** Is your firm covered by liability insurance and other insurance in amounts required in the contract specifications or have the ability to obtain the required insurance in the amounts required in the specifications after notice of award?

Yes \_\_\_\_ No \_\_\_\_

**Q.** Does your firm qualify as a carrier-insured employer or a self-insured employer under ORS 656.407 or has elected coverage under ORS 656.128?

Yes \_\_\_\_ No \_\_\_\_

**R.** Has your firm complied with the tax laws of the State or a political subdivision of the State, including ORS 305.620 and ORS Chapters 316, 317 and 318?

Yes \_\_\_\_ No \_\_\_\_

**5) COMPLETE and ATTACH the City of The Dalles Conflict of Interest Disclosure Form**

**6) CERTIFICATION STATEMENT**

I certify that the foregoing statements and information provided in all sections of this application are correct and true as of the date of this application and that I am authorized to bind this company contractually. I further certify that any additional information requested by the City to process this application will be true and correct.

\_\_\_\_\_  
Name

\_\_\_\_\_  
Title

\_\_\_\_\_  
Signature

\_\_\_\_\_  
Date

\_\_\_\_\_  
Company Name

## CONFLICT OF INTEREST (COI) DISCLOSURE FORM

Firms under Contract or proposing to enter into a Contract with Agency must be in conformance with the "City of The Dalles (COTD) Conflict of Interest Guidelines" available on the Internet at: [www.ci.thedalles.or.us/engineering](http://www.ci.thedalles.or.us/engineering). The definitions of terms used in this COI Disclosure Form shall be those provided in the City of The Dalles Conflict Of Interest Guidelines (note that "Public Official" includes all Agency employees).

**This COI Disclosure Form is submitted in response to (check only one):**

- Agency RFP# \_\_\_\_\_ [or] ITB# \_\_\_\_\_
- Contract # \_\_\_\_\_
- Price Agreement # \_\_\_\_\_ WOC# \_\_\_\_\_ [or] PO# \_\_\_\_\_
- Changes to COI Disclosure Form previously submitted for (RFP # \_\_\_\_\_, ITB # \_\_\_\_\_, Price Agreement # \_\_\_\_\_, WOC # \_\_\_\_\_, Contract # \_\_\_\_\_)

**This COI Disclosure Form must be signed in ink by a principal of the Firm to certify that it is correct. A Firm's certification that its disclosure form is correct includes the disclosure by its Associates and Subcontractors.**

My signature certifies that as disclosed on or attached to the present form:

- (a) the Firm's disclosures are complete, accurate, and not misleading.
- (b) the Firm has provided the City of The Dalles COI Guidelines to all Associates and Subcontractors (if any) and the present form includes or has attached any required COI disclosures from those sources.

**I hereby certify that I am authorized to sign this COI Disclosure Form as a Representative for the Firm identified below:**

**Complete Legal Name of Firm:** \_\_\_\_\_

**Address:** \_\_\_\_\_

**Telephone:** \_\_\_\_\_

**Fax No:** \_\_\_\_\_

**Signature:** \_\_\_\_\_ **Date:** \_\_\_\_\_

**Please answer all questions "Yes", "No" or "N/A" (if uncertain answer "Yes.") If the answer to any of the questions is "Yes," then use the applicable "Comments" fields to:**

(a) furnish all relevant facts that are necessary to make the response complete, accurate, and not misleading; and

(b) identify any actions that must be taken to avoid, neutralize, or mitigate such conflict of interest (e.g. communications barriers, restraint or restriction upon future contracting activities, or other precaution)

1. a) Is any Associate of the Firm a former employee of Agency within the last year? **No**  **Yes**
- b) Is any Associate of the Firm a Relative or Member of the Household of a current Agency employee that had or will have any involvement with this Procurement or Contract Authorization? **No**  **Yes**

**If the answer to either of the above questions is "Yes", complete the attached "Relatives and Former Agency Employees -Roles and Signatures" table (Part A and/or Part B, as applicable).**

2. Does the Firm or any Associate of the Firm have an Actual, Apparent or Potential Conflict Of Interest ("Individual" or "Organizational") with regard to any known member of an Agency Procurement evaluation or selection team? **No**  **Yes**  **Comments:**

3. Did the Firm or any Associate of the Firm conduct prior work on the Project described in the Procurement, or participate in preparing any part of the Procurement or any documents or reports related to the Procurement or to which the Procurement refers? **No**  **Yes**  **Comments:**
4. Does the Firm or any Associate of the Firm have any past, present or currently planned personal or financial interests which are an Actual, Apparent or Potential Conflict of Interest ("Individual" or "Organizational"), with respect to the Procurement or award of this Contract or performing the work for Agency or acquisition of any real property for the Project? **No**  **Yes**  **Comments:**
5. Has the Firm or an Associate of the Firm offered to a Public Official, or is the Firm aware of any Public Official that has solicited or received, directly or indirectly, any pledge or promise of employment or other benefit based on the understanding that the Public Official's vote, official action or judgment would be influenced thereby? **No**  **Yes**  **Comments:**
6. Has (or will) the Firm or an Associate of the Firm provided a direct beneficial financial interest to any person within two years after the person ceased to hold a position as a Public Official who was involved in the Procurement or Authorization for the Contract, or is the Firm aware of any such person or Public Official who has or will receive a direct beneficial financial interest within the two year period? **No**   
**Yes**  **Comments:**
7. Is the Firm aware of any current or former Public Official that has an Actual, Apparent or Potential Conflict Of Interest with respect to the Procurement or award of this Contract or performing the work for Agency? **No**  **Yes**  **Comments:**
8. Does the prospective Contract/WOC include development of an Environmental Assessment (EA) or Environmental Impact Statement (EIS)? **No**  **Yes**
- If yes**, in accordance with the disclosure statement requirements of Council on Environmental Quality Regulation, 40 C.F.R 1506.5(c), does the Firm have any financial or other interest in the outcome of this Project; and/or does the Firm have any agreement, enforceable promise, or guarantee to provide any future work on this Project? **No**  **Yes**  **Comments:**
9. Have Subcontractors or other Associates furnished COI Disclosure Forms, separate from the present form, which included conflicts or potential conflicts of interest? (If yes, attach the disclosures.)  
**No**  **Yes**  **N/A**  **Comments:**
10. If the prospective Contract/WOC includes personal services for the purpose of administering, managing, monitoring, inspecting, evaluating compliance with or otherwise overseeing a public contract, is the Firm or an Associate or an Affiliate of the Firm a party to the subject public contract?  
**No**  **Yes**  **N/A**  **Comments:**
11. Has the Firm or any Associate of the Firm entered into personal services contract(s) with Agency for the purpose of advising or assisting in developing specifications, a scope or statement of work, an invitation to bid, a request for proposals or other solicitation documents and materials related to this procurement?  
**No**  **Yes**  **Comments:**

## Relatives and Former Agency Employees - Roles and Signatures

For each employee of the Firm that was employed by Agency within the last year, state the job the employee performed for Agency, the role the employee now serves for the Firm and the date the employee left Agency. Use Part B for Firm Associates with Relatives or Members of the Household working for Agency that had or will have involvement with this Procurement or Contract.

<b>Part A: Employees that left Agency in the last year.</b>			
<b>Employee Name/Signature</b>	<b>Job Performed for Agency</b>	<b>Current Role with Firm</b>	<b>Date left Agency</b>
Name: _____ Sign: _____ <ul style="list-style-type: none"> <li>• Involved with this Procurement on behalf of COTD? <b>No</b> <input type="checkbox"/> <b>Yes</b> <input type="checkbox"/></li> <li>• Involved with Proposal development for this Procurement? <b>No</b> <input type="checkbox"/> <b>Yes</b> <input type="checkbox"/></li> </ul>			
Name: _____ Sign: _____ <ul style="list-style-type: none"> <li>• Involved with this Procurement on behalf of COTD? <b>No</b> <input type="checkbox"/> <b>Yes</b> <input type="checkbox"/></li> <li>• Involved with Proposal development for this Procurement? <b>No</b> <input type="checkbox"/> <b>Yes</b> <input type="checkbox"/></li> </ul>			
Name: _____ Sign: _____ <ul style="list-style-type: none"> <li>• Involved with this Procurement on behalf of COTD? <b>No</b> <input type="checkbox"/> <b>Yes</b> <input type="checkbox"/></li> <li>• Involved with Proposal development for this Procurement? <b>No</b> <input type="checkbox"/> <b>Yes</b> <input type="checkbox"/></li> </ul>			
<b>Part B: Identify Associates of the Firm that are Relatives or Members of the Household of Agency employees currently working for Agency, if the Agency employee had or will have any involvement with this Procurement or Contract.</b>			
<b>Firm Associate's Name</b>	<b>Name and Relationship of Relative or Member of Household Employed at Agency</b>	<b>Role at Agency</b>	<b>Agency employee's Role with this Procurement</b>

(Make copies of this form as needed to list additional employees.)

**BID FORM**

Offer of \_\_\_\_\_ (**Bidder**), organized and existing under the laws of the State of \_\_\_\_\_, doing business as \_\_\_\_\_, to the **CITY OF THE DALLES**, an Oregon municipal corporation.

In compliance with the Advertisement and Invitation for Bids, Bidder hereby proposes to perform all Work necessary for

**CONTRACT NO. 2025-010  
WESTSIDE INTERCEPTOR-PHASE 2**

in strict accordance with the solicitation and Contract Documents, within the time set forth herein, and at the prices stated below.

By submission of this Offer, each Bidder certifies (and, in the case of a joint Offer, each party certifies as to their own organization) this Offer has been arrived at independently, without consultation, communication, or agreement as to any matter relating to this Offer with any other Offer or with any competitor.

Bidder hereby agrees to commence Work under this Contract on or before a date to be specified in the Notice to Proceed and to fully complete the project by **June 12, 2026**. Bidder further agrees to pay liquidated damages of the sum calculated at the per diem rate set forth in Part 00100 of 2025 City of The Dalles Standard Specifications for Construction – General Conditions (available on the City’s website) for each consecutive calendar day thereafter for which the Contractor is in breach of the Contract.

Bidder further states the provisions of ORS 279C.838, 279C.840 or 40 U.S.C. 3141 to 3148 will be complied with.

Bidder, in supplying this Offer, acknowledges the receipt of the Contract Document package.

Bidder agrees to perform all the Work described in the Contract Documents for the following unit prices and lump sum:

<b>Item Number</b>	<b>Approximate Quantity</b>	<b>Units</b>	<b>Description</b>	<b>Unit Price</b>	<b>Extended Amount</b>
<b>1</b>	<b>1</b>	<b>LS</b>	<b>Mobilization</b>		
<b>2</b>	<b>1</b>	<b>LS</b>	<b>Traffic Control</b>		
<b>3</b>	<b>1</b>	<b>LS</b>	<b>Erosion &amp; Sediment Control</b>		
<b>4</b>	<b>1</b>	<b>LS</b>	<b>Construction Surveying</b>		
<b>5</b>	<b>10</b>	<b>CY</b>	<b>Concrete Removal</b>		
<b>6</b>	<b>1280</b>	<b>CY</b>	<b>Asphalt Removal</b>		
<b>7</b>	<b>1078</b>	<b>LF</b>	<b>Construct Concrete Curb with 24” Gutter</b>		

**Bid Form**

Project No. 2025-010 WESTSIDE INTERCEPTOR-PHASE 2

8	1	EA	Construct ADA Ramp		
9	1041	LF	Remove Concrete Curb		
10	1	LS	Demolish Railroad Crossing		
11	1	EA	Remove Catch Basin		
12	1	EA	Construct Catch Basin (G-2)		
13	1	EA	Construct Catch Basin (CG-3)		
14	88	SY	Construct Concrete Sidewalk		
15	70	CY	¾"-0" Aggregate Base (Sidewalk/Trail)		
16	2650	TON	Level 2, ½" ACP		
17	3	EA	Adjust Valve To Grade		
18	9	EA	Adjust Manhole To Grade		
19	4850	LF	Install 4" Method B Methyl Methacrylate Pavement Marking		
20	175	LF	Install 12" Method B Methyl Methacrylate Pavement Marking		
21	2	EA	Connect to Existing Storm Drain		
22	650	CY	Rock Excavation (Storm Drain)		
23	10	CY	Boulder Excavation (Storm Drain)		
24	380	LF	Abandon/Remove Storm Drain Pipe		
25	2	EA	Abandon/Demolish Storm Drain Manhole		
26	3	EA	Construct 84" Dia. Storm Drain Manhole		
27	375	LF	Install 48" Dia. Storm Drain Pipe (Class B Backfill)		
28	19	LF	Install 12" Dia. Storm Drain Pipe (Class B Backfill)		
29	10	CY	Trench Foundation (Storm Drain)		
30	4	EA	Connect to Existing Sanitary Sewer		
31	3185	LF	Abandon/Remove Sanitary Sewer Pipe		
32	9	EA	Abandon/Demolish Sanitary Sewer Manhole		
33	2250	CY	Rock Excavation (Sanitary Sewer)		
34	10	CY	Boulder Excavation (Sanitary Sewer)		
35	72	LF	Install 8" Sanitary Sewer Pipe (Class B Backfill)		

**Bid Form**

Project No. 2025-010 WESTSIDE INTERCEPTOR-PHASE 2

Page 2 of 3

36	3191	LF	Install 30" Sanitary Sewer Pipe (Class B Backfill)		
37	1	EA	Construct 48" Dia. Sanitary Sewer Manhole		
38	13	EA	Construct 60" Dia. Sanitary Sewer Manhole		
39	1	EA	Construct 72" Dia. Sanitary Sewer Manhole		
40	1	EA	Construct 84" Dia. Sanitary Sewer Drop Manhole		
41	500	CY	Trench Foundation (Sanitary_Sewer)		

Total Bid Amount: \$\_\_\_\_\_

Bidder acknowledges, through the submission of this Offer, the Work to be performed for this Project shall require close coordination with the City of The Dalles and its other contractors.

\_\_\_\_\_  
**Bidder**                      *Name*                      *Title*                      *Date*

**BID SECURITY**

**KNOW ALL PEOPLE BY THESE PRESENTS** that we, \_\_\_\_\_, as Principal (**Contractor**), and \_\_\_\_\_, a corporation organized and existing under the laws of the State of \_\_\_\_\_ and duly authorized to transact a SURETY business in the State of Oregon, as surety (**SURETY**), are held and firmly bound unto the **CITY OF THE DALLES**, an Oregon municipal corporation, in the full sum of ten (10) percent of the total amount of Contractor's OFFER for the Work hereinafter described, for the payment of which, well and truly to be made, we bind ourselves, our heirs, executors, administrators and assigns, and successors and assigns, firmly by these presents.

**THE CONDITIONS** of this obligation are such that, whereas Contractor is herewith submitting to the CITY OF THE DALLES a certain OFFER for the following Work, to wit:

**CONTRACT NO. 2025-010  
WESTSIDE INTERCEPTOR-PHASE 2**

said OFFER and its solicitation, by this reference being made a part hereof;

**NOW, THEREFORE**, if the said OFFER submitted by Contractor is accepted and the Contract for said Work be awarded to Contractor, and if Contractor enters into and executes said Contract and furnishes bonds as required within the time required, then this obligation shall be void; otherwise to remain in full force and effect.

***Signature page follows.***

**IN WITNESS WHEREOF**, Contractor and SURETY have caused these presents to be signed and sealed this \_\_\_\_\_ day of \_\_\_\_\_, 2025.

\_\_\_\_\_  
**PRINCIPAL**

*BY*

\_\_\_\_\_  
*TITLE*

\_\_\_\_\_  
**SURETY**

*BY*

\_\_\_\_\_  
*Attorney-in-Fact*

**NOTE**

*If the Principal is operating under an assumed business name there must also be set forth in the first paragraph of the bond, the names of all the partners or the individuals owning the business, and the bond must be executed by one of them.*

*If the Principal is a corporation, the bond must be executed by one of the officers authorized to execute bonds, showing the officer's official title and the seal of the corporation.*

**FIRST-TIER SUBCONTRACTOR DISCLOSURE FORM**

**Project No.:** 2025-010  
**Project Name:** WESTSIDE INTERCEPTOR-PHASE 2  
**Bid Closing:** October 23, 2025 at 2:00pm

This Form must be submitted at the location specified in the Invitation to Bid on the advertised bid closing date and within two (2) working hours after the advertised bid closing time.

List below the name of each subcontractor potentially furnishing labor or materials and is required to be disclosed, the category of Work the subcontractor would be performing, and the dollar value of the subcontract. Enter **NONE** if there are no subcontractors requiring disclosure consistent with Oregon Public Contracting Code. *Attach additional sheets if needed.*

<b>Subcontractor</b>	<b>Category of Work</b>	<b>Dollar Value</b>

*Failure to submit this Form by the disclosure deadline will result in a nonresponsive Bid which will not be considered for award.*

\_\_\_\_\_                      \_\_\_\_\_                      \_\_\_\_\_                      \_\_\_\_\_  
**Bidder**                      **Name**                      **Title**                      **Date**



**NON-COLLUSION AFFIDAVIT**

**Contract Bid No. 2025-010**

**WESTSIDE INTERCEPTOR-PHASE 2**

State of \_\_\_\_\_

County of \_\_\_\_\_

I state that I am (title) \_\_\_\_\_ of (name of firm) \_\_\_\_\_ and that I am authorized to make this affidavit on behalf of my firm, and its owners, directors, and officers. I am the person responsible in my firm for the price(s) and the amount of this bid.

I state that:

A. The price(s) and amount of this bid have been arrived at independently and without consultation, communication or agreement with any other contractor, bidder or potential bidder, except as disclosed on the attached appendix.

B. That neither the price(s) nor the amount of this bid, and neither the approximate prices(s) nor approximate amount of this bid, have been disclosed to any other firm or person who is a bidder or potential bidder, and they will not be disclosed before bid opening.

C. No attempt has been made or will be made to induce any firm or person to refrain from bidding on this contract, or to submit a bid higher than this bid, or to submit any intentionally high or noncompetitive bid or other form of complementary bid.

D. The bid of my firm is made in good faith and not pursuant to any agreement or discussion with, or inducement from, any firm or person to submit a complementary or other noncompetitive bid.

E. (name of firm) \_\_\_\_\_, its affiliates, subsidiaries, officers, directors and employees are not currently under investigation by any governmental City and have not in the last four years been convicted of or found liable for any act prohibited by State of Federal law in any jurisdiction, involving conspiracy or collusion with respect to bidding on any public contract, except as described on the attached appendix.

I state that (name of firm) \_\_\_\_\_ understands and acknowledges that the above representations are material and important, and will be relied on by City of The Dalles, Oregon in awarding the contract(s) for which this bid is submitted. I understand and my firm understands that any misstatement in this affidavit is and shall be treated as fraudulent concealment from City of The Dalles, Oregon of the true facts relating to the submission of bids for this contract.

\_\_\_\_\_  
(Name of Company/Position)

Sworn to and subscribed before me this \_\_\_ day of \_\_\_\_\_, 2025.

\_\_\_\_\_  
NOTARY PUBLIC FOR OREGON

My Commission expires: \_\_\_\_\_

RESPONSIBILITY DETERMINATION FORM

Project Name: **WESTSIDE INTERCEPTOR-PHASE 2**

Contract Number: 2025-010

Business Entity Name: \_\_\_\_\_

CCB License Number: \_\_\_\_\_

Form Submitted By: City of The Dalles, Oregon

City's Representative: Name: \_\_\_\_\_  
Title: \_\_\_\_\_  
Date: \_\_\_\_\_

The City of The Dalles has done all of the following:

- Checked the list created by the Construction Contractors Board under ORS 701.227 for bidders who are not qualified to hold a public improvement contract.
- Determined whether the bidder has met the standards of responsibility. In so doing, the City has considered whether the bidder:
  - Has available the appropriate financial, material, equipment, facility and personnel resources and expertise, or the ability to obtain the resources and expertise, necessary to meet all contractual responsibilities.
  - Holds current licenses that businesses or service professionals operating in this state must hold in order to undertake or perform the work specified in the contract.
  - Is covered by liability insurance and other insurance in amounts required in the solicitation documents.
  - Qualifies as a carrier-insured employer or a self-insured employer under ORS 656.407 or has elected coverage under ORS 656.128.
  - Has disclosed the bidder's first-tier subcontractors in accordance with ORS 279C.370.
  - Has a satisfactory record of performance.

- Has a satisfactory record of integrity.
- Is qualified legally to contract with the City.
- Has supplied all necessary information in connection with the inquiry concerning responsibility.
- Has complied with the tax laws of the State or a political subdivision of the State, including ORS 305.620 and ORS Chapters 316, 317, and 318.

Determined the bidder to be one of the following:

- Responsible under ORS 279C375(2)(a) and (b).
- Not responsible under ORS 279C.375(2)(a) and (b)

**NOTICE OF AWARD**

**TO:**

**PROJECT DESCRIPTION:                    CONTRACT NO. 2025-010  
WESTSIDE INTERCEPTOR-PHASE II**

The City has considered the **BID** submitted by you for the above described work in response to its Advertisement for Bids dated **September 2, 2025**.

You are hereby notified that your **BID** has been accepted for the amount \$\_\_\_\_\_

You are required by the General Conditions to execute the Contract and furnish the required **Contractor's Performance Bond, Payment Bond, and Original Certificates of Insurance** within fifteen (15) calendar days from the date of receipt of this notice.

If you fail to execute said Contract and to furnish said **BONDS** and original certificates of insurance within fifteen (15) days from the date of this Notice, the **CITY** will be entitled to consider all of your rights arising out of the **CITY'S** acceptance of your **BID** as abandoned and forfeit your **BID BOND**. The City will be entitled to such other rights as may be granted by law.

**BEFORE ON-SITE WORK CAN COMMENCE**, the following items below need to be completed (00180.40(b)):

- Contract Submittals – Submitted 5 days prior to a preconstruction meeting
  - Project Work Schedule (00180.41)
  - Traffic Control Plan (00225.05)
  - Pollution Control Plan (00290.30)
  - Erosion and Sediment Control Plan (00280.04)
  - Trucking Service Agreement (if any) (00180.20(e)(1) and 00180(e)(3))
  - Material Submittals (i.e. backfill, pipe, manhole) (00165)
  - Curb Ramp Plan (00759.02)
- Schedule and attend the Preconstruction Meeting with representatives from the CITY.

**Only after the preconstruction meeting is held, project submittals are reviewed and approved and issuance of the Notice to Proceed can On-site Work for the project begin.**

You are required to return an acknowledged copy of this **NOTICE OF AWARD** to the **CITY**.

Dated this \_\_\_\_\_ day of \_\_\_\_\_, **2025**.

**CITY OF THE DALLES, OREGON**

By \_\_\_\_\_  
MICHAEL H. BOSSE, PE  
Title CITY ENGINEER

**ACCEPTANCE OF NOTICE**

Receipt of the above **NOTICE OF AWARD** is hereby acknowledged

By \_\_\_\_\_  
(Company Name)

this the \_\_\_\_\_ day of \_\_\_\_\_, 2025.

By \_\_\_\_\_ Title \_\_\_\_\_



## City of The Dalles

Department of Public Works  
1215 West 1<sup>st</sup> Street  
The Dalles, OR 97058

---

### PREVAILING WAGE NOTE

This project is subject to Oregon prevailing wage law. All workers shall be paid no less than the applicable prevailing wage rate for the type of work being performed. The current “Prevailing Wage Rates for Public Works Contracts in Oregon” published by the Oregon Bureau of Labor and Industries shall apply to this contract. Current copies of the “Prevailing Wage Rates for Public Works Contracts in Oregon” may be obtained by contacting Oregon Bureau of Labor and Industries at (971) 673-0761 or by downloading a copy at: [www.oregon.gov/boli/WHD/PWR/Pages/pwr\\_state.aspx](http://www.oregon.gov/boli/WHD/PWR/Pages/pwr_state.aspx)

Current Prevailing Wage Rates for this project are the July 5, 2025 published rates

July 5, 2025 published rates:

[July 5, 2025 Prevailing Wage Rates](#)

Oregon Bureau of Labor and Industries

# Prevailing Wage Rates for Public Works Contracts



Christina E. Stephenson  
Labor Commissioner  
Rates Effective July 5, 2025



## PART 2

# CONTRACT BOOKLET

WESTSIDE INTERCEPTOR-PHASE 2  
CONTRACT NO. 2025-010

## PUBLIC WORKS AGREEMENT

<b>Contractor</b>	[NAME]
<b>Consideration</b>	[\$AMOUNT]
<b>Effective Date</b>	November 12, 2025
<b>Completion Date</b>	June 12, 2026
<b>Project/Services</b>	<i>Project No. 2025-010 WESTSIDE INTERCEPTOR-PHASE 2</i>

This PUBLIC WORKS AGREEMENT (**Agreement**) is entered by the City of The Dalles, an Oregon municipal corporation (**City**) and [contractor], an [entity] (**Contractor**), for Contractor's provision of Construction services to the City.

**WHEREAS**, the City requires performance of certain public works described in the solicitation for Project No. 2025-010, attached to and made part of this Agreement as **Exhibit A**; and

**WHEREAS**, Contractor desires to perform those certain public works and services pursuant to the compensation and conditions set forth herein.

**NOW, THEREFORE**, in consideration of both the provisions set forth herein and other good and valuable consideration, the receipt and sufficiency of which is here acknowledged, the Parties agree:

### A. Contractor's Duties

1. Scope of Work. Contractor agrees, at its expense, to furnish all labor, equipment, materials, expertise, tools, supplies, insurance, licenses, reference and background data and information, including subcontractors approved under this Agreement, and provide any equipment necessary to perform all tasks described in Contractor's scope of work, attached to and made part of this Agreement as **Exhibit B** (together with the services solicited through Exhibit A, **Work**). The Parties agree the Work shall be interpreted broadly to the City's benefit: Contractor agrees to perform all subordinate tasks not explicitly referenced in **Exhibits A and B** but necessary to fully and effectively perform those specifically listed tasks.
2. Examination. Contractor agrees it examined the project site and the contract documents connected with the solicitation for this Work prior to its submittal of its bid. The Parties agree Contractor's submission of a bid for this Agreement's award is expressly considered prima facie evidence Contractor made such an examination and is satisfied as to the conditions to be encountered in its performance of the Work and as to the requirements of the contract documents. Contractor agrees to protect itself in the unit prices or the lump sum proposed on the Work. Contractor agrees its failure to visit or thoroughly familiarize itself with the labor, equipment, and material required, the difficulty of the conditions involved, or the scope of the project or the Work shall neither relieve Contractor of its obligation to complete the Work and perform under this Agreement for the price proposed nor entitle Contractor to a price adjustment.



3. Insurance and Indemnity.

- a. Insurance. Contractor agrees, at its expense, to carry and maintain in effect throughout this Agreement's term (at least) the following coverage policies:
- (i) **Workers' Compensation** coverage in the amount of \$1,000,000;
  - (ii) **Comprehensive General Liability** insurance covering property damage and bodily injury in the amount of \$1,000,000 (*per occurrence*) and \$3,000,000 (*in aggregate*);
  - (iii) **Mobile Equipment Liability** insurance in the amount of \$500,000 (*per occurrence*) and \$2,000,000 (*in aggregate*);
  - (iv) **Contractors Pollution Liability** insurance in the amount of \$1,000,000;
  - (v) **Pollution Liability** insurance (including coverage for automobiles transporting hazardous materials) through a Commercial General Liability policy approved by the City as to terms, conditions, and form and is Pollution Specific with a minimum limit of \$2,000,000 (*per occurrence*) and \$3,000,000 (*in aggregate*) written on either (a) a full occurrence form, (b) a limited occurrence form with at least a three-year tail, or (c) a claims-made form with a three-year tail; and
  - (vi) **Commercial Automobile Liability** insurance (including coverage for all owned, hired, and non-owned vehicles) with a *combined single limit per occurrence* of \$2,000,000.
- b. Certificates. Contractor agrees to provide the City with certificates of insurance naming the **City of The Dalles, its employees, officials, and agents** as an additional insured prior to commencement of the Work performed under this Agreement and to further provide the City *thirty (30) days'* written notice before cancelling or reducing any insurance policy contemplated by this Agreement. Contractor agrees its failure to notice the City of cancellation of or reduction to any insurance policy contemplated by this Agreement is, at the City's sole discretion, grounds for immediate termination of this Agreement.
- c. Subcontractor Insurance. Contractor agrees to require its subcontractors performing Work under this Agreement to carry and maintain in effect throughout this Agreement's term Workers' Compensation coverage, Commercial General Liability, Pollution Liability, and Commercial Automobile Liability with coverage's equivalent to those listed in Section A(3)(a) of this Agreement. Contractor further agrees to require those subcontractors to provide Contractor with certificates of insurance as evidence of coverage and (upon City's request) provide the City with certificates of insurance for any subcontractor performing Work under this Agreement. The Parties agree this subsection survives the expiration or sooner termination of this Agreement.
- d. Workers' Compensation. Contractor agrees it is solely responsible for maintaining proper and adequate Workers' Compensation coverage. If



Contractor's insurance does not cover each and every subcontractor, certificates of insurance issued on policies covering each and every subcontractor shall be filed with the City prior to commencement of the Work, including any subcontract operations. Contractor shall provide the City with evidence it is either a *self-insured employer* or a *carrier-insured employer* for Workers' Compensation pursuant to ORS Chapter 656 prior to commencing any Work.

- e. Indemnity. Contractor agrees to indemnify, defend, and hold harmless the City, its officers, agents, and employees against all liability, loss, and costs arising from actions, suits, claims, or demands for Contractor's (including Contractor's officers, agents, employees, and subcontractors) acts or omissions in the performance of this Agreement; provided, however, in no event does Contractor agree to such indemnification, defense, or holding harmless due to the City's sole negligence.

#### 4. Payments and Retainage.

- a. Prompt Payment. Contractor agrees to promptly pay as due all persons supplying labor or materials for the prosecution of services or Work arising from this Agreement: if Contractor (including subcontractors) fails, neglects, or refuses to make prompt payment of any claim for labor or services furnished to Contractor (including subcontractors), the City may pay such a claim and charge the amount of its payment against funds actually or expectedly due from Contractor plus a non-waivable *nine (9%) percent* interest commencing at the end of the ten-day period within which payment is due under ORS 279C.580(4), unless payment is subject to a good faith dispute as defined in ORS 279C.580. The Parties agree payment of any claim in this manner shall not relieve Contractor or its surety from any obligations with respect to any unpaid claims. Any person supplying labor or materials in connection with this Agreement may file a complaint with the Construction Contractors Board against Contractor (including subcontractors) stemming from Contractor's (including subcontractors') failure, neglect, or refusal to promptly pay them as due, unless payment is subject to a good faith dispute as defined in ORS 279C.580, only if the person has not been paid in full and gives written notice of claim pursuant to ORS 279C.605 to Contractor and the City.
- b. Industrial Accident Fund. Contractor agrees to pay all contributions or amounts due the Industrial Accident Fund from the Contractor or subcontractors incurred in the performance of this Agreement.
- c. Labor Hours. Contractor agrees to pay all employees at least time and half pay for all overtime worked in excess of *forty (40) hours* in any one work week, except for excluded individuals pursuant to ORS 653.010 to 653.261 or 29 U.S.C. 201 to 209. Contractor further agrees to abide by all other restrictions governing labor hours on public contracts pursuant to ORS 279C.540 and 279C.545, including time limitations on claims for overtime.
- d. Medical Care. Contractor agrees to promptly pay as due all persons, co-partnerships, associations, or corporations furnishing medical, surgical, hospital care, or other needed care and attention incident to sickness or injury to



Contractor's employees, or all sums which Contractor agrees to pay for such services, and all moneys and sums which Contractor collected or deducted from the wages of its employees pursuant to any law or contract for the purpose of providing or paying for such service.

- e. No Liens. Contractor shall not permit any lien or claim to be filed or prosecuted against the City on account of any Work (including labor or materials) furnished under this Agreement.
- f. Employee Withholdings. Contractor agrees to pay to the Oregon Department of Revenue all sums withheld from its employees pursuant to ORS 316.167.
- g. Retainage. The Parties agree retainage shall be withheld and released in accordance with ORS 279C.550 to 279C.580, as follows:
  - (i) Retainage Generally. Contractor agrees the City may reserve as retainage from any progress payment an amount not to exceed *five (5%) percent* of the payment. As Work progresses, the City may reduce the retained amount and may eliminate retainage on any remaining monthly payments after *fifty (50%) percent* of the Work is completed if, in the City's opinion, such Work is progressing satisfactorily. The Parties agree elimination or reduction of retainage is allowed only upon Contractor's written application, which application must include Contractor's surety's written approval; provided, however, when the Work is *ninety-seven and one-half (97.5%) percent* completed, the City may, at its discretion and without Contractor's application, reduce the retained amount to *one hundred (100%) percent* of the value of the Work remaining to be done. Upon receipt of Contractor's written application, the City agrees to respond (in writing) within a reasonable time.
  - (ii) Form of Retainage. In accordance with ORS 279C.560 and any applicable administrative rules, unless the City finds in writing accepting a bond, security, or other instrument described in options (a) or (c) below poses an extraordinary risk not typically associated with the bond, security, or instrument, the City agrees to approve Contractor's written request:
    - (a) to be paid amounts which would otherwise have been retained from progress payments where Contractor has deposited with the City bonds, securities, or other instruments specified in ORS 279C.560 or in a custodial account or other mutually-agreed account satisfactory to the City, with an approved bank or trust company, to be held in lieu of the cash retainage for the City's benefit. Interest or earnings on the bonds, securities, or other instruments shall accrue to the Contractor. The Contractor agrees to execute and provide such documentation and instructions respecting the bonds, securities, and other instruments as the City may require to protect its interests. To be permissible, the bonds, securities, and other instruments must be of a character approved by the City Attorney;



- (b) retainage be deposited in an interest-bearing account in a bank, savings bank, trust company, or savings association for the City's benefit, with interest from such account accruing to the Contractor; or
- (c) the Contractor be allowed, with the City's approval, to deposit a surety bond for the City's benefit, in a form acceptable to the City Attorney, in lieu of all or a portion of funds retained or to be retained. Such bond and any proceeds therefrom shall be made subject to all claims and liens in the manner and priority as set forth for retainage under ORS 279C.550 to ORS 279C.625. Where the City has accepted Contractor's election of any of the options above, the City may recover from Contractor any additional costs incurred through such election by reducing Contractor's final payment. Where the City has agreed to Contractor's request to deposit a surety bond under this option (c), Contractor agrees accept like bonds from its subcontractors and suppliers from which Contractor has required retainage to support the Work.

If the City accepts bonds, securities, or other instruments deposited as provided in options (a) and (c), the City agrees to reduce the moneys held as retainage in an amount equal to the value of the bonds, securities, and other instruments and pay the amount of the reduction to Contractor in accordance with ORS 279C.570.

- (iii) Interest. The retainage held by the City shall be included in and paid to Contractor as part of the final payment of the Contract Price. The City agrees to pay Contractor interest at the rate of *one and one-half* (1.5% per month) *percent per month* on the final payment due Contractor, with interest commencing *thirty* (30) *days* after the Work has been completed and accepted and running until the date Contractor must notify the City in writing it considers the Work complete, and the City agrees, within *fifteen* (15) *days* after receiving the written notice, to either accept the Work or notify Contractor of Work yet to be performed. If the City does not within the time allowed notify Contractor of Work yet to be performed to fulfill its contractual obligations, the interest provided by this subsection shall commence to run *thirty* (30) *days* after the end of the 15-day period.
- (iv) Contractor's Retainage. If Contractor pays a subcontractor in full, including the amount Contractor withheld as retainage, the City agrees to pay Contractor (out of the amount the City withheld from Contractor as retainage) a sum equal to the amount of retainage Contractor paid its subcontractor. Contractor agrees to notice the City in writing when it pays a subcontractor in full under this subsection and the City agrees to pay Contractor the amount due Contractor under this subsection within *fifteen* (15) *days* after it receives notice. The City agrees to pay interest on the amount due Contractor at the rate of *one* (1% per month) *percent per month* commencing *thirty* (30) *days* after the City receives Contractor's notice of full payment to the subcontractor.
- (v) Subcontractor Retainage. If Contractor elects to reserve a retainage from any progress payment due any subcontractor or supplier, Contractor agrees such retainage shall not exceed *five* (5%) *percent* of the payment and such



retainage withheld from subcontractors and suppliers shall be subject to the same terms and conditions stated in this Agreement as applicable to the City's retainage from any progress payment due Contractor; provided, however, if (in accordance with ORS 279C.560) Contractor has deposited bonds, securities, or other instruments or has elected to have the City deposit accumulated retainage in an interest-bearing account, Contractor agrees to comply with ORS 701.435 respecting the deposit of bonds, securities, or other instruments by subcontractors and suppliers and the sharing of interest earnings with subcontractors and suppliers.

5. Prevailing Wage Rates, Retainage, and Bonds.

- a. Prevailing Wage Rates. Contractor agrees to comply with the prevailing wage provisions of ORS 279C.800 through 279C.870. The Oregon Bureau of Labor and Industries (**BOLI**) determines and publishes the existing Oregon prevailing wage rates in its publication *Prevailing Wage Rates for Public Works Contracts in Oregon*. Contractor agrees to pay workers performing Work not less than the specified minimum hourly wage rate according to ORS 279C.838 and ORS 279C.840, and further specifically agrees to include this requirement in any subcontracts relating to the Work or this Agreement.
- b. Certification and Prevailing Wage Retainage. Contractor (including subcontractors) agrees to submit written certified statements to the City on the form prescribed by BOLI's Commissioner in OAR 839-025-0010 certifying compliance with wage payment requirements and accurately setting out Contractor's (including subcontractors') weekly payroll records for each worker performing Work. Contractor (including subcontractors) agree to preserve the certified statements for a period of *six (6) years* from the Completion Date. Contractor agrees the City will retain *twenty-five (25%) percent* of any amount earned by the Contractor under this Agreement until the Contractor has filed the certified statements required by ORS 279C.845(7). The City agrees to pay Contractor the amount retained within *fourteen (14) days* after Contractor files the required certified statements, regardless of whether subcontractors failed to file certified statements.
- c. Contractor's Prevailing Wage Retainage. Contractor agrees to retain *twenty-five (25%) percent* of any amount earned by a first-tier subcontractor under this Agreement until the subcontractor files with the City the certified statements required by ORS 279C.845. Before paying any amount retained, Contractor agrees to verify the first-tier subcontractor filed the certified statement. Within *fourteen (14) days* after the first-tier subcontractor files the required certified statement, Contractor agrees to pay the subcontractor any amount retained.
- d. Bonds. Before starting any Work under this Agreement, and using the forms of bonds attached to and made part of the solicitation document for Project No. 2025-010 (and thus this Agreement) where applicable, Contractor (including its sureties) agrees:
  - (i) to file a **public works bond** with the Construction Contractors Board in the amount of \$30,000 and consistent with ORS 279C.836, unless Contractor or



its subcontractors are eligible to elect not to so file or are otherwise exempt from filing pursuant to ORS 279C.836(4), (7), (8), or (9), and further specifically agrees to include this requirement in any subcontracts relating to the Work or this Agreement;

- (ii) to execute and deliver to the City Manager a **performance bond** in an amount equal to the full contract price conditioned on the faithful performance of this Agreement in accordance with its plans, specifications, and conditions; and
- (iii) to execute and deliver a **payment bond** in an amount equal to the full contract price, solely for the protection of claimants under ORS 279C.600.

6. Other.

- a. Solicitation. Contractor agrees to each and every obligation or restriction imposed by the solicitation document for Project No. 2025-010 and this Agreement, all as if incorporated here; Contractor further specifically agrees such obligations or restrictions are supplemental to its duties under this Agreement. In the event of a conflict between any provision of the solicitation document for this Agreement and this Agreement, the Parties agree to attempt to reconcile the apparently conflicting provisions so as to harmonize them; if the Parties fail to reasonably harmonize such provisions, the terms of this Agreement control.
- b. Final Inspection and Acceptance. Upon completion, Contractor agrees to notice the City in writing it completed the Work so the City can undertake a final inspection. The City agrees to inspect the Work (and all records generated by Contractor relating to the Work) within *fifteen (15) days* of its receipt of Contractor's completion notice. The City agrees to either accept the work or notice Contractor of any defects or remaining performance necessary to fully complete the Work. The City agrees to provide Contractor its final acceptance of the Work once it determines all of the Work has been performed satisfactorily.
- c. Drug Testing. Contractor agrees to demonstrate to the City it has an employee drug testing program in place before it commences performance of this Agreement.
- d. Environmental Compliance. Contractor agrees to abide all applicable ordinances, rules, and regulations dealing with the prevention of environmental pollution and the preservation of natural resources impacting the performance of this Agreement, including (without limitation) ORS Chapters 459 (Solid Waste Management), 459A (Reuse and Recycling), 465 (Hazardous Waste and Hazardous Material I), 466 (Hazardous Waste and Hazardous Materials II), 467 (Noise Control), 468 (Environmental Quality Generally), 468A (Air Quality), and 468B (Water Quality), the associated Oregon Administrative Rules promulgated by Oregon Department of Environmental Quality, plus all other reasonably similar or relevant local, state, or federal laws.



- e. Tax Currency. Contractor agrees (and by executing this Agreement, certifies under penalty of perjury) it is, to the best of its knowledge, not in violation of any tax laws described in ORS 305.380.

## B. City's Duties

1. Compensation.
  - a. Total. The City agrees to compensate Contractor for the Work in an amount not to exceed **\$[AMOUNT]** [at the rate of **\$[amount]**], to be paid [method].
  - b. Progress Payments. The City agrees to make progress payments upon Contractor's completion of the Work and delivery of an invoice detailing the Work, subject to the City's approval and no more frequently than monthly. Payment shall be made only for Work actually completed as of the invoice date. The City shall pay Contractor interest on its progress payments (not including retainage) commencing *thirty (30) days* after receiving Contractor's invoice or *fifteen (15) days* after payment is approved by the City, whichever is earlier. The Parties agree ORS 279C.570(2) determines the rate of interest charged to the City for this subsection's purpose.
  - c. Satisfaction. Contractor agrees the City's payment of an invoice releases the City from any further obligation to compensate Contractor for the Work (including expenses) incurred as of the invoice date. The Parties agree payment shall not be considered acceptance or approval of the Work or waiver of any defects therein.
  - d. Public Budgeting. The City certifies sufficient funds are available and authorized for expenditure to finance the costs of this Agreement during the current fiscal year. The Parties agree appropriations for future fiscal years are subject to budget approval by the City Council.
  - e. Other Duties. The City agrees to reasonably satisfy any commitments it made in this Agreement's solicitation.

## C. General Conditions

1. Time. The Parties agree time is of the essence to this Agreement's performance: Contractor's prosecution of the Work shall begin without undue delay on or after the Effective Date and shall be completed before or on the Completion Date, all as subject to Section C(8); provided, however, the Parties agree Contractor will not perform any on-site Work prior to the City's issuance of a *Notice to Proceed*, which the City agrees to send once Contractor submits all required information and documentation pursuant to this Agreement.
2. Termination/Modification. This Agreement's term expires naturally upon the Parties' full performance or on the Completion Date (whichever first) unless sooner modified pursuant to this Agreement. The Parties agree the City may terminate this Agreement with *seven (7) days'* notice and Contractor may terminate this Agreement with *thirty (30) days'* notice, both without penalty. The City agrees to compensate



Contractor for all approved services rendered prorated to the date the City notices its intent to terminate. The Parties agree termination of this Agreement is subject to ORS 279C.655. The Parties agree this Agreement may only be modified by a written instrument duly executed by the Parties.

3. Full Integration/Conflict. This Agreement contains the Parties' entire understanding and intent and supersedes all prior negotiations, representations, or other written or oral agreements on this matter (including the City's solicitation for the Work and the applicable *City of The Dalles Standard Specifications for Construction – General Conditions*). If any of the negotiations or documents mentioned in this subsection conflict with the terms of this Agreement, the Parties expressly agree the provisions of this Agreement control.
4. Independent Contractor. The Parties agree Contractor is an *independent contractor* as defined by ORS 670.600(2) and as interpreted by regulations promulgated by BOLI. Neither the terms of this Agreement nor the course of its performance by the Parties shall be construed as implicating an employer-employee relationship. Contractor expressly warrants its exclusive agency free from City direction and control over the means and manner of completing the Work.
5. Assignment/Delegation. The Parties agree no Party shall assign or transfer an interest or duty under this Agreement without the other Party's written consent and any attempted assignment or delegation without written consent shall be invalid.
6. Subcontractors.
  - a. List. Contractor agrees to provide the City with a list of proposed subcontractors within *ten (10) days* of this Agreement's mutual execution and before awarding any subcontract connected with the Work or this Agreement, and shall not retain any subcontractor the City reasonably objects to as incompetent or unfit.
  - b. Responsibility. Contractor agrees it is as fully responsible to the City for its subcontractors' and employees' (whether directly or indirectly employed) negligent acts and omissions as it is for its employees' negligent acts and omissions.
  - c. Registration. Contractor agrees (and by executing this Agreement, certifies) all subcontractors performing Work under this Agreement will be registered with the Construction Contractors Board in accordance with ORS 701.035 to 701.055 before they commence any Work.
  - d. No Privity. Contractor agrees all of its subcontracts under this Agreement shall provide the Work performed under the subcontract shall be performed according to the terms of this Agreement; whether stated in the subcontract, Contractor agrees to remain solely responsible for the administration of the subcontract, including (without limitation) the performance of the subcontracted Work, progress of the subcontracted Work, payment for accepted subcontracted Work, and disputes and claims for additional compensation regarding all subcontracted Work. The Parties agree nothing in this Agreement is intended to or shall create any contractual privity between the City and any subcontractor.



- e. *Mandatory Construction Contract Clauses*. Contractor agrees to include in each subcontract for property or services it enters with a first-tier subcontractor (including a material supplier) for the purpose of performing a *construction* contract to support the Work:
- (i) a payment clause obligating Contractor to pay the first-tier subcontractor for satisfactory performance under the subcontract within *ten (10) days* out of amounts the City pays to Contractor under this Agreement;
  - (ii) a clause requiring Contractor to provide a first-tier subcontractor with a standard form the first-tier subcontractor may use as an application for payment or as another method by which the subcontractor may claim a payment due from Contractor;
  - (iii) a clause requiring Contractor, except as otherwise provided in this subsection, to use the same form and regular administrative procedures for processing payments during the entire term of the subcontract. Contractor may change the form or the regular administrative procedures Contractor uses for processing payments if the Contractor (a) notifies the subcontractor in writing at least *forty-five (45) days* before the date on which Contractor makes the change and (b) includes with the written notice a copy of the new or changed form or a description of the new or changed procedure; and
  - (iv) an interest penalty clause obligating Contractor, if Contractor does not pay the first-tier subcontractor within *thirty (30) days* after receiving payment from the City, to pay the first-tier subcontractor and interest penalty on amounts due in each payment the Contractor does not make in accordance with the payment clause included in the subcontract under Section C(6)(e)(i). Contractor or its first-tier subcontractor is not obligated to pay an interest penalty if the only reason Contractor or its first-tier subcontractor did not make payment when payment was due is neither received payment from the City or Contractor when payment was due. The interest penalty (a) applies to the period beginning on the day after the required payment date and ends on the date on which the amount due is paid and (b) is computed at the rate specified in ORS 279C.515(2).
- f. *Mandatory Payment Clause*. Contractor agrees to include in each subcontract it enters with a first-tier subcontractor for the purpose of performing *any* contract to support the Work a clause requiring the first-tier subcontractor to include a payment clause and an interest penalty clause conforming to the standards of Section C(6)(e) in each of the first-tier subcontractor's subcontracts and to require each of its first-tier subcontractor's subcontractors to include such clauses in the first-tier subcontractors' subcontracts with each lower-tier subcontractor or supplier.
7. *Enforceability*. The Parties agree all disputes connected with this Agreement or its performance shall be heard in the Circuit Court of the State of Oregon for the County of Wasco and any resolutions shall be construed under the laws of the State of



Oregon. If any provision of this Agreement is held invalid and unenforceable, the remaining provisions shall be valid and binding upon the Parties.

8. Liquidated Damages. Contractor agrees to prosecute the Work vigorously to completion and consistent with Section C(1). Contractor agrees delays in its performance under this Agreement will cause the City to sustain damages, increase risk to, inconvenience, and interfere with the public and commerce, and increase costs to taxpayers; accordingly, because the City finds it unduly burdensome and difficult to demonstrate the exact dollar value of such damages, Contractor specifically agrees to be subject to the provisions of Section 00180.85(b) of the applicable *City of The Dalles Standard Specifications for Construction – General Conditions* and pay the City (not as a penalty but as liquidated damages) the amounts determined by that Section 00.180.85(b) for each day the Work remains incomplete after the expiration of the contract time or adjusted contract time applicable to that Work. The Parties further agree any such damages paid pursuant to this subsection constitute payment in full only of damages incurred by the City due to Contractor's failure to complete the Work on time.
9. Waiver. The Parties agree a Party's failure to insist upon strict adherence to a provision of this Agreement on any occasion shall not be considered a waiver of the Party's rights or deprive the Party of the right to thereafter insist upon strict adherence to the provision or any other provision of this Agreement.
10. Force Majeure. The Parties agree neither Party shall be held responsible for delay in the performance of this Agreement caused by circumstances beyond their control and making performance commercially impracticable, illegal, or impossible. The City may terminate this Agreement upon written notice after determining such delay will unreasonably prevent successful performance of this Agreement.

***Continues on next.***



11. Notices. All notices required or permitted to be given under this Agreement shall be deemed given and received *two (2) days* after deposit in the United States Mail, certified or registered form, postage prepaid, return receipt requested, and addressed:

*To the City:* City Manager  
City of The Dalles  
313 Court Street  
The Dalles, OR 97058

*To Contractor:* [Name]  
[Contractor]  
[Address]  
[Address]

**IN WITNESS WHEREOF**, the Parties duly execute this **PUBLIC WORKS AGREEMENT** this \_\_\_\_ day of \_\_\_\_\_, 2025.

**CITY**

**CONTRACTOR**

\_\_\_\_\_  
Matthew B. Klebes, City Manager

\_\_\_\_\_  
[Name], [Title]

**ATTEST:**

\_\_\_\_\_  
Amie Ell, City Clerk

**Approved as to form:**

\_\_\_\_\_  
Jonathan M. Kara, City Attorney



**PERFORMANCE BOND**

Bond Number: \_\_\_\_\_

Amount: \$XXXX

**KNOW ALL PEOPLE BY THESE PRESENTS** that we, [contractor name], as Principal (Contractor), and \_\_\_\_\_ a corporation organized and existing under the laws of the State of \_\_\_\_\_, and duly authorized to transact a SURETY business in the State of Oregon, as SURETY, are held and firmly bound unto the **CITY OF THE DALLES**, an Oregon municipal corporation, in the sum of [contract amount written out] Dollars [contract amount in dollars(\$XXXX)], lawful money of the United States of America, for the payment whereof well and truly to be made, we and each of us, jointly and severally, bind ourselves, our and each of our heirs, executors, administrators, successors and assigns firmly by these presents.

**THE CONDITIONS** of this obligation are such that, whereas the above Principal did enter into a Contract with the City of The Dalles for **Project No. 2025-010 WESTSIDE INTERCEPTOR-PHASE 2**, which Contract is made a part hereof as if fully copied herein;

**NOW, THEREFORE**, if the said principal faithfully, punctually and completely performs and abides by all covenants and conditions of said Contract, and with all laws, ordinances, regulations, and orders of the State of Oregon and the City of The Dalles, and the agencies and bureaus thereof, directly or indirectly governing or applicable to the Principal's performance under the said Contract, including but not limited to the requirements of Oregon Revised Statutes Chapter 279 relating to public contracts, which hereby is made a part hereof as if fully copied herein, then this obligation shall be null and void, otherwise to be in full force and effect.

**SURETY** agrees (1) that any extension of time allowed said Principal for completion of work or for delivery under the said contract shall not impair this obligation or reduce any period of maintenance or warranty provided in said Contract; (2) that any change made in the terms or provisions of said contract increasing the price to be paid to Principal, without notice to the SURETY shall not impair this obligation, PROVIDED that all such increases shall not in the aggregate exceed twenty-five percent (25%) of the original Contract Price without consent of the SURETY, however, any such change shall not increase the obligation of the SURETY hereunder; and (3) that this obligation shall continue to bind the said Principal and SURETY notwithstanding successive payment made hereunder for successive breaches, until the full amount of the said obligation is exhausted.

***Signature page follows.***

**IN WITNESS WHEREOF**, the Principal and Surety have caused these presents to be executed on this \_\_\_\_\_ day of \_\_\_\_\_, 2025.

\_\_\_\_\_  
**PRINCIPAL**

*BY*

\_\_\_\_\_  
*TITLE*

\_\_\_\_\_  
**SURETY**

*BY*

\_\_\_\_\_  
*Attorney-in-Fact*

**NOTE**

*If the Principal is operating under an assumed business name there must also be set forth in the first paragraph of the bond the names of all the partners or the individuals owning the business, and the bond must be executed by one of them.*

*If the Principal is a corporation, the bond must be executed by one of the officers authorized to execute bonds, showing the officers official title and the seal of the corporation.*

**PAYMENT BOND**

Bond Number: \_\_\_\_\_

Amount: \$XXXX

**KNOW ALL PEOPLE BY THESE PRESENTS** that we, [contractor name], as Principal (Contractor), and \_\_\_\_\_, a corporation organized and existing under the laws of the State of \_\_\_\_\_ and duly authorized to transact a SURETY business in the State of Oregon, as SURETY, are held and firmly bound unto the **CITY OF THE DALLES**, an Oregon municipal corporation, in the sum of [contract amount written out] Dollars [contract amount in dollars(\$XXXX)], lawful money of the United States of America, for the payment whereof well and truly to be made, we and each of us, jointly and severally, bind ourselves, our and each of our heirs, executors, administrators, successors and assigns firmly by these presents.

**THE CONDITIONS** of this obligation are such that, whereas the above Principal did enter into a Contract with the City of The Dalles for **Project No. 2025-010 WESTSIDE INTERCEPTOR-PHASE 2**, which Contract is made a part hereof as if fully copied herein;

**NOW, THEREFORE**, if the said principal faithfully, punctually and completely performs and abides by all covenants and conditions of said Contract, and with all laws, ordinances, regulations, and orders of the State of Oregon, the City of The Dalles, and the agencies and bureaus thereof, directly or indirectly governing or applicable to the Principal's performance under the said Contract, including but not limited to the requirements of Oregon Revised Statutes Chapter 279 relating to public contracts, which hereby is made a part hereof as if fully copied herein, and shall make payment promptly, as due, to the City of The Dalles and all other public entities as may be required, and to all subcontractors and to all persons supplying to the Principal or its subcontractors, equipment, supplies, labor, or materials for the prosecution of the work or any part thereof, provided for in said Contract, then this obligation shall be null and void, otherwise to be in full force and effect.

**SURETY** agrees (1) that any extension of time allowed said Principal for completion of work or for delivery under the said contract shall not impair this obligation or reduce any period of maintenance or warranty provided in said Contract; (2) that any change made in the terms or provisions of said contract increasing the price to be paid to Principal, without notice to the SURETY shall not impair this obligation, PROVIDED that all such increases shall not in the aggregate exceed twenty-five percent (25%) of the original Contract Price without consent of the SURETY, however, any such change shall not increase the obligation of the SURETY hereunder; and (3) that this obligation shall continue to bind the said Principal and SURETY notwithstanding successive payment made hereunder for successive breaches, until the full amount of the said obligation is exhausted.

***Signature page follows.***

**IN WITNESS WHEREOF**, the Principal and Surety have caused these presents to be executed on this \_\_\_\_\_ day of \_\_\_\_\_, 2025.

\_\_\_\_\_  
**PRINCIPAL**

*BY*

\_\_\_\_\_  
*TITLE*

\_\_\_\_\_  
**SURETY**

*BY*

\_\_\_\_\_  
*Attorney-in-Fact*

**NOTE**

*If the Principal is operating under an assumed business name there must also be set forth in the first paragraph of the bond, the names of all the partners or the individuals owning the business, and the bond must be executed by one of them.*

*If the Principal is a corporation, the bond must be executed by one of the officers authorized to execute bonds, showing the officer's official title and the seal of the corporation.*



**STATE OF OREGON**  
**STATUTORY PUBLIC WORKS BOND**

Surety bond #: \_\_\_\_\_ CCB # (if applicable): \_\_\_\_\_

We, \_\_\_\_\_, as principal, and \_\_\_\_\_, a corporation qualified and authorized to do business in the State of Oregon, as surety, are held and firmly bound unto the State of Oregon for the use and benefit of the Oregon Bureau of Labor and Industries (BOLI) in the sum of thirty thousand dollars (\$30,000) lawful money of the United States of America to be paid as provided in ORS chapter 279C, as amended by Oregon Laws 2005, chapter 360, for which payment well and truly to be made, we bind ourselves, our heirs, personal representatives, successors and assigns, jointly and severally, firmly by this agreement.

WHEREAS, the above-named principal wishes to be eligible to work on public works project(s) subject to the provisions of ORS chapter 279C, as amended by Oregon Laws 2005, chapter 360, and is, therefore, required to obtain and file a statutory public works bond in the penal sum of \$30,000 with good and sufficient surety as required pursuant to the provisions of section 2, chapter 360, Oregon Laws 2005, conditioned as herein set forth.

NOW, THEREFORE, the conditions of the foregoing obligations are that if said principal with regard to all work done by the principal as a contractor or subcontractor on public works project(s), shall pay all claims ordered by BOLI against the principal to workers performing labor upon public works projects for unpaid wages determined to be due, in accordance with ORS chapter 279C, as amended by Oregon Laws 2005, chapter 360, and OAR Chapter 839, then this obligation shall be void; otherwise to remain in full force and effect.

This bond is for the exclusive purpose of payment of wage claims ordered by BOLI to workers performing labor upon public works projects in accordance with ORS chapter 279C, as amended by Oregon Laws 2005, chapter 360.

This bond shall be one continuing obligation, and the liability of the surety for the aggregate of any and all claims which may arise hereunder shall in no event exceed the amount of the penalty of this bond.

This bond shall become effective on the date it is executed by both the principal and surety and shall continuously remain in effect until depleted by claims paid under ORS chapter 279C, as amended by Oregon Laws 2005, chapter 360, unless the surety sooner cancels the bond. This bond may be cancelled by the surety and the surety be relieved of further liability for work performed on contracts entered after cancellation by giving 30 days' written notice to the principal, the Construction Contractors Board, and BOLI. Cancellation shall not limit the responsibility of the surety for the payment of claims ordered by BOLI relating to work performed during the work period of a contract entered into before cancellation of this bond.

IN WITNESS WHEREOF, the principal and surety execute this agreement. The surety fully authorizes its representatives in the State of Oregon to enter into this obligation.

SIGNED, SEALED AND DATED this \_\_\_\_\_ day of \_\_\_\_\_, 20 \_\_\_\_\_

Surety by:

Principal by:

\_\_\_\_\_  
(Seal)  
*Company Name*

\_\_\_\_\_  
*Name*

\_\_\_\_\_  
*Signature*

\_\_\_\_\_  
*Signature*

\_\_\_\_\_  
*Title (e.g. Attorney-in-Fact)*

\_\_\_\_\_  
*Title*

\_\_\_\_\_  
*Address*

\_\_\_\_\_  
*Address*

\_\_\_\_\_  
*City State Zip*

\_\_\_\_\_  
*City State Zip*

**SEND BOND TO: Construction Contractors Board  
PO Box 14140  
Salem, OR 97309-5052  
Telephone: (503) 378-4621**

**NOTICE TO PROCEED**

**To:**

**Date:**

**PROJECT:                    CONTRACT NO. 2025-010  
   WESTSIDE INTERCEPTOR-PHASE 2**

The City of The Dalles has executed the contract documents for the above mentioned project. You are hereby notified to commence **WORK** in accordance with the **CONTRACT** dated \_\_, on or before \_\_\_\_\_.

**Only after the preconstruction meeting is held and project submittals are reviewed and approved, can On-site Work for the project begin.**

CITY OF THE DALLES  
PUBLIC WORKS DEPARTMENT

\_\_\_\_\_  
BY    **Michael H. Bosse PE**  
TITLE   **CITY ENGINEER**

**ACCEPTANCE OF NOTICE**

Receipt of the above **NOTICE TO PROCEED** is hereby acknowledged by

\_\_\_\_\_, this \_\_\_ day of \_\_\_\_\_, 2025.  
(Company Name)

BY \_\_\_\_\_ TITLE \_\_\_\_\_

## CERTIFICATION OF WORKERS' COMPENSATION COVERAGE

The Contractor, for the purposes of this contract, hereby certifies that it is currently providing Oregon Workers' Compensation coverage for all its employees and will maintain coverage throughout the course of the project through one of the following methods:

1.  "Carrier-Insured Employer" (State Accident Insurance Fund corp. or other authorized insurer)

Insurance Company Name \_\_\_\_\_

ID/Policy Number \_\_\_\_\_

2.  "Self-Insured Employer" (Certified by the Workers' Compensation Division)

ID number as assigned by the  
Workers' Compensation Division \_\_\_\_\_

3.  I am an independent contractor and will perform all work under this contract without the assistance of others.

In the event of cancellation or change in the information above, Contractor certifies that it will immediately notify the Department of said cancellation or change and will obtain alternate coverage.

Dated \_\_\_\_\_ 2025

\_\_\_\_\_  
(Contractor's Signature)

### REMINDER – ADDITIONAL INFORMATION NEEDED

Has your insurance carrier filed with Oregon Workers' Compensation Division a guaranty contract as proof of coverage for your employees working in Oregon?

For filing information, contact the Workers' Compensation Division at Labor and Industries Building: Salem, OR 97301; Phone (503) 947-7810



## PART 3

# SPECIAL PROVISIONS

WESTSIDE INTERCEPTOR-PHASE 2  
CONTRACT NO. 2025-010

**00110.05(e) Reference to Websites** – Add the following bullet list to the end of this subsection:

- American Traffic Safety Services Association (ATSSA)
  - [www.atssa.com](http://www.atssa.com)
- Agency - Bid Website
  - [www.thedalles.org/bids](http://www.thedalles.org/bids)
- Agency – Conflict of Interest Guidelines and Disclosure Forms
  - [https://cms8.revize.com/revize/dallessor/Departments/public works/engineering/Conflict of Interest Guidelines.pdf](https://cms8.revize.com/revize/dallessor/Departments/public%20works/engineering/Conflict%20of%20Interest%20Guidelines.pdf)
  - [https://cms8.revize.com/revize/dallessor/Departments/public works/engineering/Conflict of Interest Form.pdf](https://cms8.revize.com/revize/dallessor/Departments/public%20works/engineering/Conflict%20of%20Interest%20Form.pdf)
- Agency – Notice of Intent
  - [www.thedalles.org/bids](http://www.thedalles.org/bids)
- EquipmentWatch
  - [www.equipmentwatch.com](http://www.equipmentwatch.com)
- ODOT Construction Section
  - [www.oregon.gov/ODOT/Construction/pages/index.aspx](http://www.oregon.gov/ODOT/Construction/pages/index.aspx)
- ODOT Construction Section – Qualified Products List (QPL)
  - [www.oregon.gov/ODOT/Construction/Pages/Qualified-Products.aspx](http://www.oregon.gov/ODOT/Construction/Pages/Qualified-Products.aspx)
- ODOT Construction Surveying Manual for Contractors
  - [www.oregon.gov/ODOT/ETA/Documents\\_Geometronics/Construction-Survey-Manual-Contractors.pdf](http://www.oregon.gov/ODOT/ETA/Documents_Geometronics/Construction-Survey-Manual-Contractors.pdf)
- ODOT Estimating
  - [www.oregon.gov/ODOT/Business/Pages/Steel.aspx](http://www.oregon.gov/ODOT/Business/Pages/Steel.aspx)
- ODOT Traffic Control Plans Unit
  - [www.oregon.gov/ODOT/Engineering/Pages/Signals.aspx](http://www.oregon.gov/ODOT/Engineering/Pages/Signals.aspx)
- ODOT Traffic Standards
  - [www.oregon.gov/ODOT/Engineering/Pages/Signals.aspx](http://www.oregon.gov/ODOT/Engineering/Pages/Signals.aspx)

**00110.20 Definitions** – Add the following to this subsection:

**As-Built Drawings** – Set of Project drawings, created by the Contractor, gathered during the course of the work showing the horizontal and vertical location of all the completed work by the Contractor. The drawings will also clearly mark any deviations from the original stamped design. One set of drawings being a paper copy at either 11"X17" or 24"X36" in size and one copy of the drawings in AutoCAD format. Contractor shall verify version of AutoCAD with City prior to submittal.

**00150.90(b) All Contact Work** – Add the following bullet to the end of this subsection:

- The Contractor has completed and submitted an approved set of As-Built Drawings.

**00165.10 Materials Acceptance Guides** – Replace subsection (a) with the following:

**(a) Field-Tested Materials** - Field-tested Materials will be accepted according to the MFTP as a Type D Project. The MFTP is published once per year and is available from the ODOT Construction Section; 800 Airport Road SE; Salem, OR 97301-4798; phone 503-986-3000. The MFTP is also available on the ODOT Construction Section website (see 00110.05(e)). The most current version of the MFTP on the date of Advertisement is the version in effect for the Project.

**00180.50 Contract Time to Complete Work** – Add subsection (h) with the following:

**00180.50(h) Contract Time** - There is one Contract Time on this Project as follows:

Completion Date: June 12, 2025

**00445.10 Contract Time to Complete Work** – Replace third paragraph with the following:

For sanitary sewers provide wye fittings in the main of the same Materials as the pipe. All fittings shall be of sufficient strength to withstand all handling and load stresses encountered. Material joining the fittings to the pipe shall be free of cracks and shall adhere tightly to each joining surface.

**01120.70 As-Built Plans and System Orientation** – Replace this subsection with the following:

**01120.70 As-Built Plans and System Orientation** - Upon completion of the Work, submit As-Built Drawings showing the Work as constructed. Provide drawings on 8 1/2 inches by 11 inches, 11 inches by 17 inches, or 22 inches by 36 inches sizes. Prepare and present a training and orientation session covering the operation, adjustment and maintenance of the irrigation system. Review corrected drawings and explain all features. Show locations of drain valves, if any, on the drawings. At this session, provide the Engineer with parts lists and service manuals for all Equipment. Notify the Engineer in writing not less than 2 weeks before the proposed date of the training and orientation session. The date and time of the session will be mutually agreed to.



PART 4  
DRAWINGS

WESTSIDE INTERCEPTOR-PHASE 2  
CONTRACT NO. 2025-010

# WESTSIDE INTERCEPTOR UPGRADES - PHASE 2

## THE DALLES, OREGON

### CONTRACT NO. 2025-010

#### NOTES

##### GENERAL NOTES

1. THE LOCATION OF KNOWN UTILITIES IN THE PROJECT AREA HAVE BEEN SHOWN FOR THE CONVIENENCE OF THE CONTRACTOR. NO RESPONSIBILITY IS ASSUMED BY THE CITY OR THE ENGINEER FOR THE COMPLETENESS OR ACCURACY OF THE LOCATION, TYPE OR NUMBER OF EXISTING UTILITIES. ALL UTILITY LOCATIONS SHALL BE VERIFIED BY THE CONTRACTOR PRIOR TO CONSTRUCTION. CALL 1-800-332-2544 FOR UTILITY LOCATIONS AT LEAST 48 HOURS PRIOR TO BEGINNING EXCAVATION IN ACCORDANCE WITH STATE LAW.
2. THE CONTRACTOR AGREES THAT, IN ACCORDANCE WITH GENERALLY ACCEPTED CONSTRUCTION PRACTICES, THE CONTRACTOR WILL BE REQUIRED TO ASSUME SOLE AND COMPLETE RESPONSIBILITY FOR JOB SITE CONDITIONS DURING THE COURSE OF CONSTRUCTION OF THE PROJECT INCLUDING SAFETY OF ALL PERSONS AND PROPERTY. THIS REQUIREMENT SHALL BE MADE TO APPLY CONTINUOUSLY AND NOT BE LIMITED TO NORMAL WORKING HOURS. THE CONTRACTOR FURTHER AGREES TO DEFEND, INDEMNIFY AND HOLD THE CITY AND ENGINEER HARMLESS FROM ANY AND ALL LIABILITY, REAL OR ALLEGED, IN CONNECTION WITH THE PERFORMANCE OF THE WORK ON THIS PROJECT, EXEMPTING LIABILITY ARISING FROM THE SOLE NEGLIGENCE OF THE ENGINEER.
3. EXCAVATIONS SHALL BE ADEQUATELY SHORED, BRACED AND SHEETED SO THAT THE EARTH WILL NOT SLIDE OR SETTLE AND SO THAT ALL EXISTING IMPROVEMENTS OF ANY KIND WILL BE FULLY PROTECTED FROM DAMAGE. ANY DAMAGE RESULTING FROM A LACK OF ADEQUATE SHORING, BRACING AND SHEETING SHALL BE THE RESPONSIBILITY OF THE CONTRACTOR AND HE SHALL EFFECT NECESSARY REPAIRS OR RECONSTRUCTION AT HIS OWN EXPENSE. WHERE THE EXCAVATION FOR A CONDUIT TRENCH AND/OR STRUCTURE IS FIVE FEET OR MORE IN DEPTH, THE CONTRACTOR SHALL PROVIDE ADEQUATE SHEETING, WHICH SHALL CONFORM TO THE APPLICABLE CONSTRUCTION SAFETY ORDERS OF THE STATE OF OREGON OSHA. THE CONTRACTOR SHALL ALWAYS COMPLY WITH OSHA REQUIREMENTS.
4. IT IS THE RESPONSIBILITY OF THE CONTRACTOR TO OBTAIN PERMITS NECESSARY TO PERFORM THE WORK SHOWN IN THESE PLANS FROM THE APPROPRIATE AGENCIES.
5. THE CONTRACTOR SHALL PROVIDE FOR INGRESS AND EGRESS FOR PRIVATE PROPERTY ADJACENT TO WORK THROUGHOUT THE PERIOD OF CONSTRUCTION.
6. THE CONTRACTOR SHALL PROVIDE ALL LIGHTS, SIGNS, BARRICADES, FLAGMEN, OR OTHER DEVICES NECESSARY TO PROVIDE FOR SAFETY, TRAFFIC CONTROL AND ALL TRAFFIC CONTROL DEVICES SHALL BE IN CONFORMANCE WITH THE CITY STANDARD SPECIFICATION, LATEST EDITION.
7. THE CONTRACTOR SHALL POST EMERGENCY TELEPHONE NUMBERS FOR POLICE, FIRE, AMBULANCE, AND THOSE AGENCIES RESPONSIBLE FOR THE MAINTENANCE OF UTILITIES ON THE JOBSITE.
8. ALL QUANTITIES AND PAY ITEMS ARE AND WILL BE BASED ON HORIZONTAL MEASUREMENTS.
9. PIPE LENGTHS AND SLOPES ARE CALCULATED FROM CENTER TO CENTER OF STRUCTURES. PIPE INVERTS GIVEN FOR MANHOLES ARE AT CENTER OF MANHOLE AND NOT AT WALL PENETRATION.
10. ALL EXISTING UTILITIES AND IMPROVEMENTS THAT BECOME DAMAGED DURING CONSTRUCTION SHALL BE COMPLETELY RESTORED TO THE SATISFACTION OF THE CITY ENGINEER, AT THE CONTRACTOR'S SOLE EXPENSE.
11. IF ARCHAEOLOGICAL MATERIAL ARE UNCOVERED DURING DEMOLITION, GRADING, TRENCHING, OR OTHER EXCAVATION, EARTHWORK WITHIN 100 FEET OF THESE MATERIALS SHALL BE STOPPED UNTIL A PROFESSIONAL ARCHAEOLOGIST WHO IS CERTIFIED BY THE SOCIETY OF PROFESSIONAL ARCHAEOLOGY (SOPA) HAS HAD AN OPPORTUNITY TO EVALUATE THE SIGNIFICANCE OF THE FIND AND SUGGEST APPROPRIATE MITIGATION MEASURES, IF THEY ARE DEEMED NECESSARY.
12. SHOULD IT APPEAR THAT THE WORK TO BE DONE OR ANY MATTER RELATIVE THERETO IS NOT SUFFICIENTLY DETAILED OR EXPLAINED ON THESE PLANS, THE CONTRACTOR SHALL CONTACT THE CITY OF THE DALLES ENGINEERING DIVISION (541) 296-5401 FOR SUCH FURTHER EXPLANATIONS AS MAY BE NECESSARY.
13. THE CONTRACTOR SHALL MEET AND FOLLOW ALL NPDES REQUIREMENTS IN EFFECT AT THE TIME OF CONSTRUCTION.
14. ANY DAMAGE TO PUBLIC OR PRIVATE PROPERTY DURING CONSTRUCTION SHALL BE REPAIRED BACK TO THE ORIGINAL CONDITION OR BETTER AT THE CONTRACTOR'S EXPENSE.
15. ALL CONSTRUCTED IMPROVEMENTS SHALL BE PROTECTED FROM DAMAGE AND VANDALISM AT THE CONTRACTOR'S EXPENSE UNTIL FINAL ACCEPTANCE OF THE PROJECT BY THE CITY.
16. WHEN STREETS ARE CLOSED EXCEPT TO LOCAL TRAFFIC, CONTRACTOR SHALL CONSTRUCT A BARRICADE TO PREVENT THROUGH TRAFFIC. CONTRACTOR SHALL ALSO POST A FLAGGER OR PROVIDE SIGNAGE AT EVERY CONSTRUCTION ENTRANCE TO THE CLOSED PORTION TO ASSIST AND PROTECT THE LOCAL TRAFFIC TRAVELING THROUGH THE CLOSURE AREA.
17. CONTRACTOR SHALL CONSTRUCT TYPE 4 INLET PROTECTION PER CITY STANDARD DRAWING RD1015 ON ALL CATCH BASINS INSIDE THE PROJECT AREA. THE PROTECTION SHALL BE CONSTRUCTED BEFORE ANY EXISTING PAVEMENT IS CUT OR REMOVED AND REMAIN IN PLACE UNTIL ALL TRENCHES ARE RESURFACED.
18. THE CONTRACTOR SHALL FIELD VERIFY LOCATION AND DEPTH OF ALL EXISTING UTILITIES WHERE NEW FACILITIES CROSS. THE CONTRACTOR SHALL BE RESPONSIBLE FOR EXPOSING POTENTIAL UTILITY CONFLICTS FAR ENOUGH AHEAD OF CONSTRUCTION TO MAKE NECESSARY LINE/GRADE MODIFICATIONS WITHOUT DELAYING THE WORK. IF MODIFICATIONS ARE NECESSARY, THE CONTRACTOR SHALL NOTIFY THE DESIGN ENGINEER. ALL UTILITY CROSSINGS SHALL BE PHOTOLOGED AS NECESSARY PRIOR TO EXCAVATION OR BORING TO ALLOW THE CONTRACTOR TO AVOID GRADE OR ALIGNMENT CONFLICTS.

##### PROJECT SPECIFIC NOTES

1. OWNER: CITY OF THE DALLES  
1215 WEST FIRST STREET  
THE DALLES, OR 97058  
CONTACT: DALE MCMAHE  
PHONE: (541) 296-5401
- ENGINEER: CITY OF THE DALLES PUBLIC WORKS DEPARTMENT  
ENGINEERING DIVISION  
1215 WEST FIRST STREET  
THE DALLES, OR 97058  
CONTACT: MICHAEL BOISSE  
PHONE: (541) 296-5401
2. ALL WORK AND MATERIALS SHALL CONFORM TO THE CURRENT EDITION OF THE CITY OF THE DALLES STANDARD SPECIFICATIONS FOR CONSTRUCTION AND STANDARD DRAWINGS. THE CITY OF THE DALLES STANDARD SPECIFICATIONS FOR CONSTRUCTION AND STANDARD DRAWINGS ARE AVAILABLE FROM THE DALLES PUBLIC WORKS DEPARTMENT LOCATED AT 1215 WEST FIRST STREET; PHONE (541) 296-5401 AND ONLINE AT [www.dalles.gov](http://www.dalles.gov).
3. NO WORK SHALL DEVIATE FROM THESE PLANS UNLESS PRIOR APPROVAL IS OBTAINED FROM THE CITY. FINAL ACCEPTANCE OF ALL WORK TO BE MADE BY THE CITY OF THE DALLES.
4. THE CONTRACTOR SHALL PROCURE FROM THE CITY OF THE DALLES AND ALL OTHER APPLICABLE AGENCIES, ALL PERMITS AND LICENSES, PAY ALL CHARGES AND FEES AND GIVE ALL NOTICES NECESSARY (2 WORKING DAYS MIN.) FOR THE INSTALLATIONS OF APPLICABLE IMPROVEMENTS DELINEATED HEREON.
5. UNDERGROUND UTILITIES: PRIOR TO FINAL PREPARATION OF SUBGRADE AND PLACEMENT OF BASE MATERIAL, ALL UNDERGROUND UTILITY MAINS SHALL BE INSTALLED, COMPACTION TESTS SHALL BE PASSED AND SERVICE CONNECTION STUBBED OUT OR INSTALLED AS SHOWN ON APPLICABLE DRAWINGS.
6. THE CONTRACTOR SHALL BE HELD RESPONSIBLE FOR ANY FIELD CHANGES MADE WITHOUT WRITTEN AUTHORIZATION FROM THE CITY.
7. ALL WELLS, IF ANY, LOCATED WITHIN THE PROJECT SHALL BE SEALED AT THE OWNER'S EXPENSE AND IN ACCORDANCE WITH OREGON DEPT. OF ENVIRONMENTAL QUALITY SPECIFICATIONS.
8. RELOCATION OF OVERHEAD LINES SHALL BE THE RESPONSIBILITY OF THE OWNER. THE CONTRACTOR SHALL COORDINATE SCHEDULING OF ALL WORK.
9. ALL SALVAGE OF PUBLIC WORKS FACILITIES SHALL BE THE PROPERTY OF THE CITY OF THE DALLES AND SHALL BE DELIVERED TO THE CITY PUBLIC WORKS DEPARTMENT.
10. CONTRACTOR SHALL BE RESPONSIBLE FOR LOCATING AND PRESERVING ALL EXISTING SURVEY MONUMENTATION WITHIN THE WORK AREA IN ACCORDANCE WITH ORS 209.150 AND/OR 209.155. IF MONUMENTATION OR ITS ACCESSORIES ARE INADEQUATELY OR OTHERWISE DISTURBED OR DESTROYED, APPLICANT SHALL BE RESPONSIBLE FOR ALL COSTS AND COORDINATION ASSOCIATED WITH ITS REESTABLISHMENT BY A PROFESSIONAL LICENSED SURVEYOR.
11. A BYPASS PUMPING AND CONTINGENCY PLAN SHALL BE SUBMITTED AND APPROVED BEFORE ANY ON-SITE WORK COMMENCES. ANY COSTS ASSOCIATED WITH THIS PLAN OR THE PUMPING ITSELF SHALL BE CONSIDERED INCIDENTAL TO THE PIPE INSTALLATION IT IS ASSOCIATED WITH.
12. ANY PAVEMENT STRIPING DAMAGED OR REMOVED AS PART OF THE PROJECT SHALL BE REINSTATED AFTER THE PAVING FOR THE PROJECT IS COMPLETE.

##### CONSTRUCTION NOTES - DUST CONTROL

1. THE CONTRACTOR SHALL TAKE EFFECTIVE ACTION TO PREVENT THE FORMATION OF ANY AIRBORNE DUST NUISANCE AND SHALL BE RESPONSIBLE FOR ANY DAMAGE RESULTING FROM FAILURE TO DO SO.
2. THE CONTRACTOR SHALL IMPLEMENT THE FOLLOWING DUST CONTROL PRACTICES:
  - A. DURING CONSTRUCTION
    1. MATERIAL EXCAVATED OR GRADED SHALL BE SUFFICIENTLY WATERED OR TREATED WITH AN APPROVED DUST CONTROL ADDITIVE TO PREVENT DUST TO THE SATISFACTION OF THE PROJECT MANAGER OR INSPECTOR.
    2. CONTRACTOR SHALL SUBMIT TO THE CITY A DUST CONTROL PLAN AND MONITORING SCHEDULE TWO (2) DAYS PRIOR TO COMMENCING WORK.
    3. AREAS OF EARTH EXPOSED BY CLEARING, EARTHMOVING, OR EXCAVATION SHALL BE MINIMIZED AT ALL TIMES.
    4. DURING GRADING AND CONSTRUCTION, STREETS AND ALLEYS NEXT TO WORK AREA SHALL BE SWEEP AT LEAST ONCE A DAY, AND AS REQUIRED BY THE CITY TO REMOVE SILT WHICH MAY HAVE ACCUMULATED FROM CONSTRUCTION ACTIVITIES.

#### CONTROL

EXISTING CONTROL PT. #	NORTHING	EASTING	ELEVATION
1 (SHT. C3.1)	709853.28	8022597.61	122.33
2 (SHT. C3.2)	710108.82	8022938.28	124.05
3 (SHT. C3.5)	709086.41	8023831.92	126.82
4 (SHT. C3.8)	708315.67	8024965.77	109.01

CENTERLINE CONTROL PT. #	NORTHING	EASTING
1	709812.20	8022611.85
2	710108.61	8022938.48
3	710165.01	8023000.63
4	709255.08	8023710.33
5	708978.48	8023997.93
6	708887.89	8024106.32
7	708891.73	8024109.53
8	708858.51	8024141.61
9	708811.65	8024189.08
10	708616.38	8024447.98
11	708444.66	8024708.93
12	708378.10	8024820.27
13	708316.18	8024924.53
14	708243.43	8025036.45

##### BENCHMARK

PROJECT BENCHMARK: 5/8" REBAR AT SOUTHWEST INTERSECTION OF WEBBER STREET RIGHT OF WAY AND UNION PACIFIC RIGHT OF WAY  
NORTHING: 709853.28 EASTING: 8022597.61 ELEV: 122.33



VICINITY MAP

NO SCALE

#### SHEET INDEX

TITLE AND NOTE SHEET	C0.1
TOPOGRAPHIC SURVEY	C1.1-C1.8
LAYOUT PLAN	C3.1-C3.8
PLAN AND PROFILE SHEET	C5.1-C5.8
DETAIL SHEETS	C7.1-C7.6

NO.	DATE	REVISIONS



CITY OF THE DALLES  
PUBLIC WORKS DEPARTMENT  
1215 West First Street  
The Dalles, Oregon 97058  
(541) 296-5401



A COVER SHEET AND GENERAL NOTES FOR:  
**WESTSIDE INTERCEPTOR UPGRADES - PHASE 2**  
THE DALLES, OREGON

NAME	MHB
DATE	9/2/2025
SCALE	NO SCALE
CHECKED	
SHEET	C0.1
OF	31 SHEETS
JOB NO.	2025-010

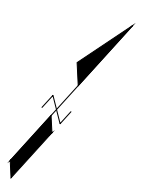
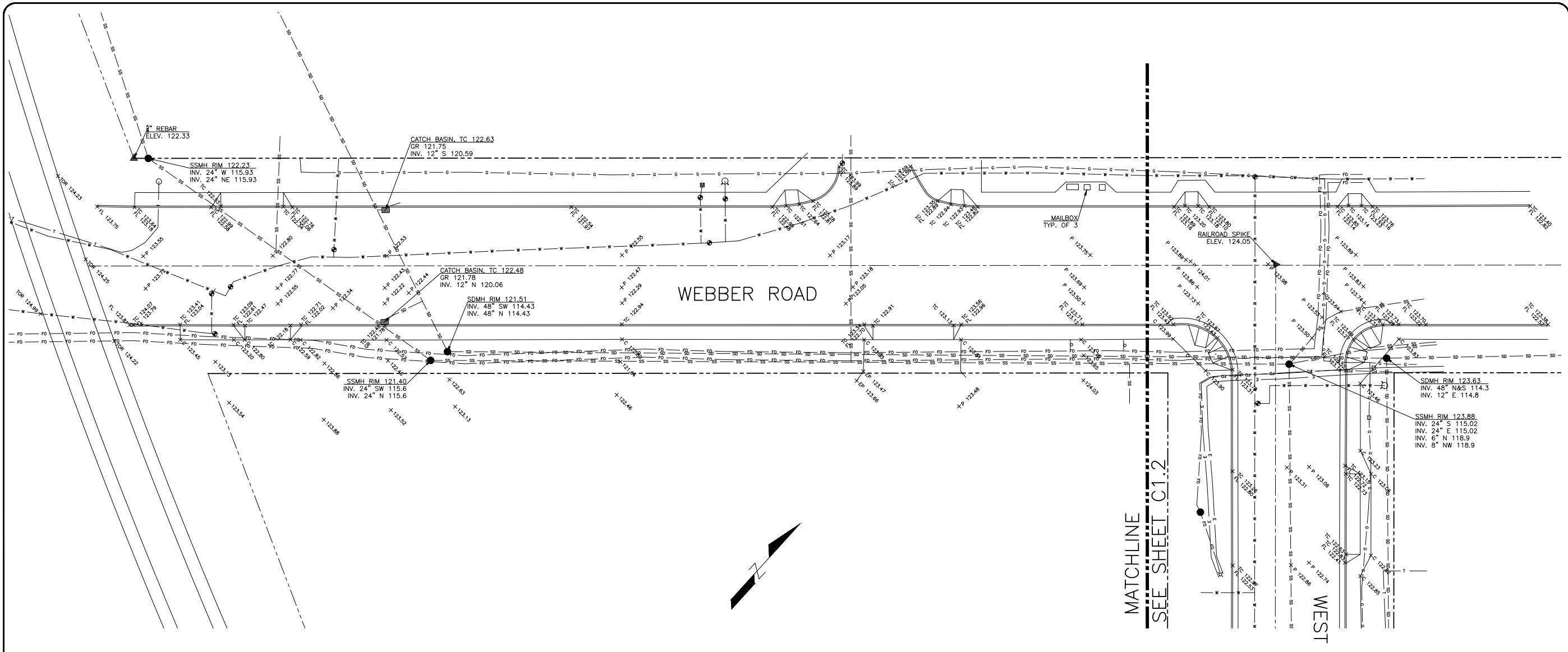

### LEGEND

FL	FLOWLINE	⊗	WATER VALVE, UNLESS NOTED OTHERWISE
TC	TOP OF CURB	⊙	FIRE HYDRANT
P	TOP OF PAVEMENT	EP	EDGE OF PAVEMENT
SW	SWALE	▲	FOUND MONUMENT
HP	HINGE POINT	⊖	SIGN
TOE	TOE OF SLOPE	⊞	WATER METER
C	TOP OF CONCRETE	TOR	TOP OF RAIL
EG	EDGE OF GRAVEL		
●	MANHOLE		
○	EXISTING GROUND ELEVATION		
⊙	DECIDUOUS TREE		
⊙	EVERGREEN TREE		
GR	GRAVEL		
⊕	POWER POLE		

MATCHLINE  
SEE SHEET C1.2

WEST FIRST STREET

**REDUCED**  
 APPROXIMATELY HALF-SCALE

THE EXISTING UNDERGROUND UTILITY LINES SHOWN ARE BASED ON THE LOCATION OF VISIBLE SURFACE IMPROVEMENTS AND BASEMAPS. ALTHOUGH EVERY EFFORT HAS BEEN MADE TO ACCURATELY SHOW THE UNDERGROUND UTILITY LINES, IT WILL BE NECESSARY TO CONFIRM THE LOCATIONS BY CALLING 1-800-332-2344 FOR UTILITY LOCATIONS PRIOR TO DIGGING.

NO.	DATE	REVISIONS

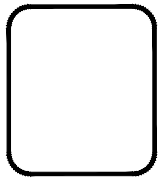

**CITY OF THE DALLES**  
 PUBLIC WORKS DEPARTMENT  
 1215 West First Street  
 The Dalles, Oregon 97058  
 (541) 296-5401



A TOPOGRAPHIC SURVEY FOR:  
**WESTSIDE INTERCEPTOR  
 UPGRADES - PHASE 2**  
 THE DALLES, OREGON

NAME	MHB
DATE	02/14/2024
SCALE	1"=20'
CHECKED	
SHEET	
<b>C1.1</b>	
OF	31 SHEETS
JOB NO.	2025-010

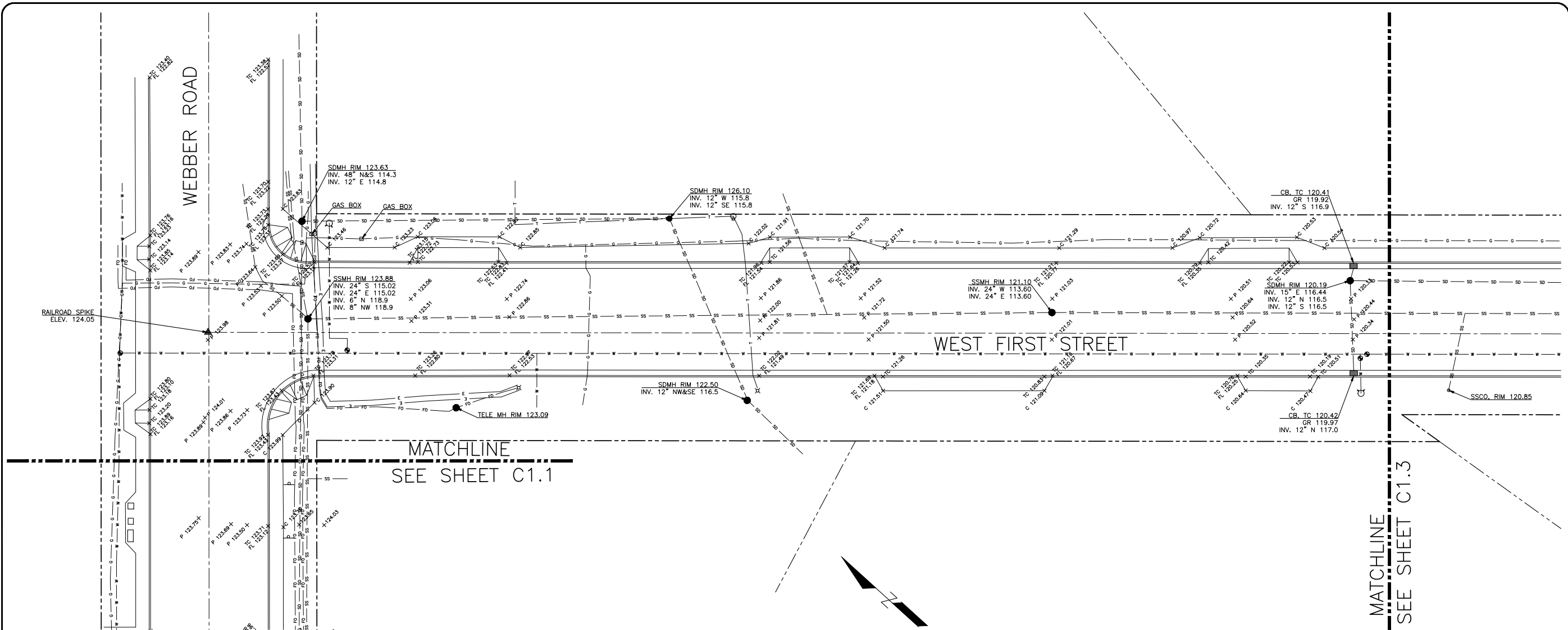

### LEGEND

FL	FLOWLINE	⊙	WATER VALVE, UNLESS NOTED OTHERWISE
TC	TOP OF CURB	⊙	FIRE HYDRANT
P	TOP OF PAVEMENT	EP	EDGE OF PAVEMENT
SW	SWALE	▲	FOUND MONUMENT
HP	HINGE POINT	⊖	SIGN
TOE	TOE OF SLOPE	⊞	WATER METER
C	TOP OF CONCRETE	TOR	TOP OF RAIL
EG	EDGE OF GRAVEL		
●	MANHOLE		
⊙	EXISTING GROUND ELEVATION		
⊙	DECIDUOUS TREE		
⊙	EVERGREEN TREE		
GR	GRAVEL		
⊙	POWER POLE		

**REDUCED**  
 APPROXIMATELY HALF-SCALE

THE EXISTING UNDERGROUND UTILITY LINES SHOWN ARE BASED ON THE LOCATION OF VISIBLE SURFACE IMPROVEMENTS AND BASEMAPS. ALTHOUGH EVERY EFFORT HAS BEEN MADE TO ACCURATELY SHOW THE UNDERGROUND UTILITY LINES, IT WILL BE NECESSARY TO CONFIRM THE LOCATIONS BY CALLING 1-800-332-2344 FOR UTILITY LOCATIONS PRIOR TO DIGGING.

NO.	DATE	REVISIONS

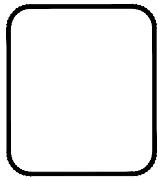

**CITY OF THE DALLES**  
 PUBLIC WORKS DEPARTMENT  
 1215 West First Street  
 The Dalles, Oregon 97058  
 (541) 296-5401

A TOPOGRAPHIC SURVEY FOR:  
**WESTSIDE INTERCEPTOR  
 UPGRADES - PHASE 2**  
 THE DALLES, OREGON

NAME	MHB
DATE	02/14/2024
SCALE	1"=20'
CHECKED	
SHEET	<b>C12</b>
OF	31 SHEETS
JOB NO.	2025-010

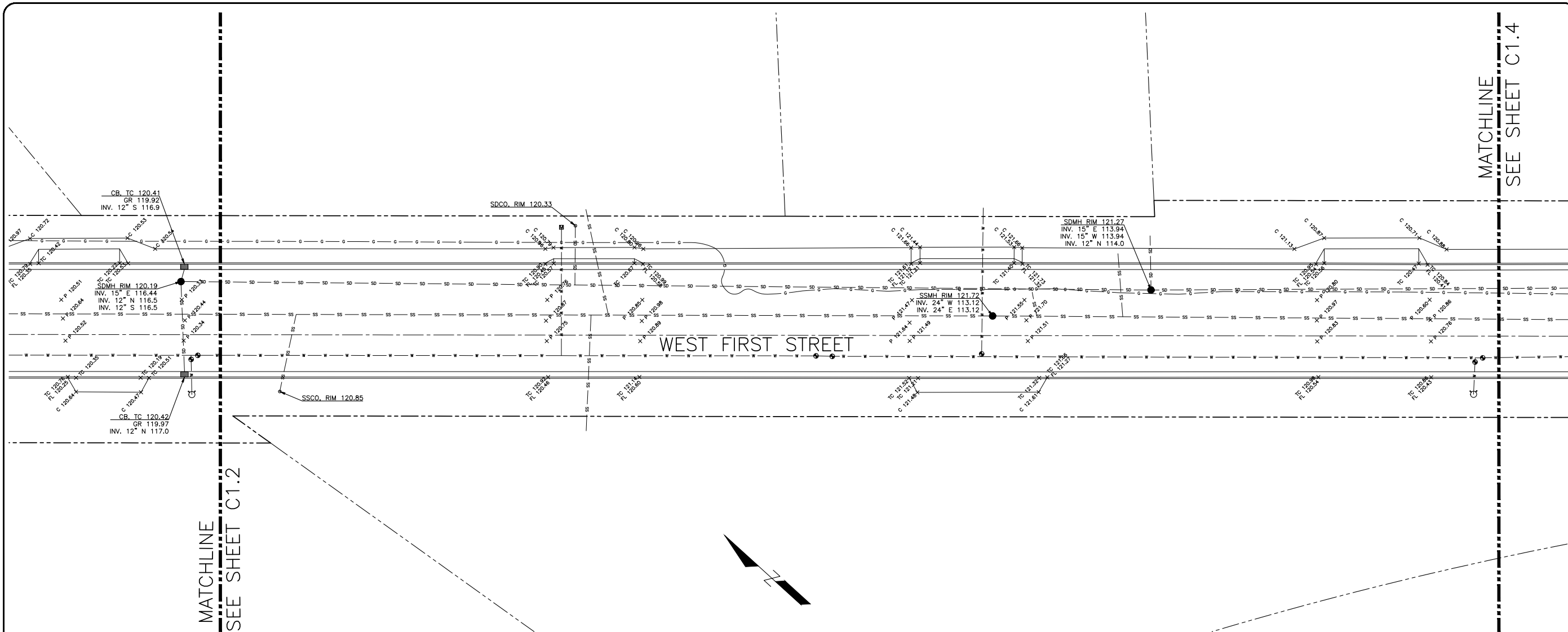

### LEGEND

FL	FLOWLINE	⊙	WATER VALVE, UNLESS NOTED OTHERWISE
TC	TOP OF CURB	⊕	FIRE HYDRANT
P	TOP OF PAVEMENT	EP	EDGE OF PAVEMENT
SW	SWALE	▲	FOUND MONUMENT
HP	HINGE POINT	+	SIGN
TOE	TOE OF SLOPE	⊞	WATER METER
C	TOP OF CONCRETE	TOR	TOP OF RAIL
EG	EDGE OF GRAVEL		
●	MANHOLE		
000	EXISTING GROUND ELEVATION		
⊙	DECIDUOUS TREE		
⊙	EVERGREEN TREE		
GR	GRAVEL		
⊕	POWER POLE		

**REDUCED**  
 APPROXIMATELY HALF-SCALE

THE EXISTING UNDERGROUND UTILITY LINES SHOWN ARE BASED ON THE LOCATION OF VISIBLE SURFACE IMPROVEMENTS AND BASEMAPS. ALTHOUGH EVERY EFFORT HAS BEEN MADE TO ACCURATELY SHOW THE UNDERGROUND UTILITY LINES, IT WILL BE NECESSARY TO CONFIRM THE LOCATIONS BY CALLING 1-800-332-2344 FOR UTILITY LOCATIONS PRIOR TO DIGGING.

NO.	DATE	REVISIONS

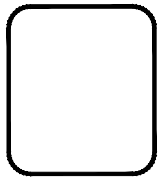

**CITY OF THE DALLES**  
 PUBLIC WORKS DEPARTMENT  
 1215 West First Street  
 The Dalles, Oregon 97058  
 (541) 296-5401



A TOPOGRAPHIC SURVEY FOR:  
**WESTSIDE INTERCEPTOR  
 UPGRADES - PHASE 2**  
 THE DALLES, OREGON

NAME	MHB
DATE	02/14/2024
SCALE	1"=20'
CHECKED	
SHEET	
	<b>C13</b>
OF	31 SHEETS
JOB NO.	2025-010

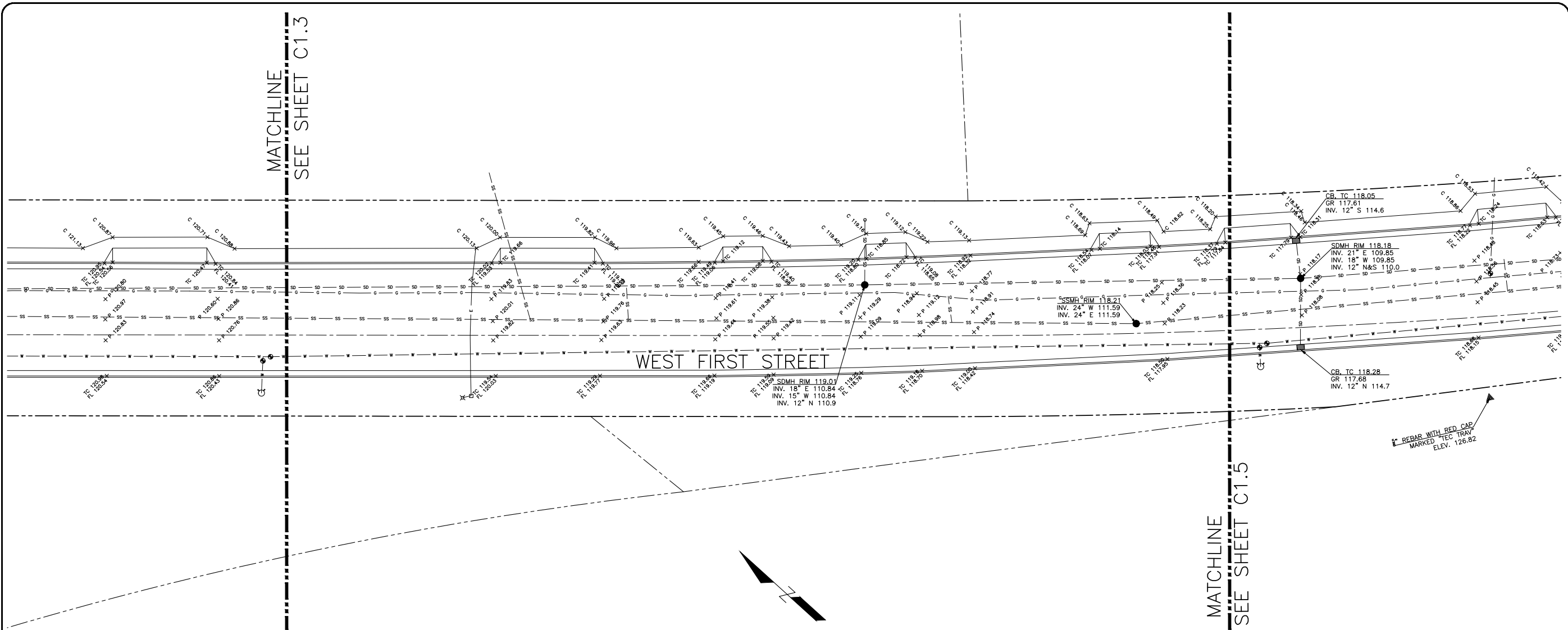

### LEGEND

FL	FLOWLINE	⊗	WATER VALVE, UNLESS NOTED OTHERWISE
TC	TOP OF CURB	○	FIRE HYDRANT
P	TOP OF PAVEMENT	EP	EDGE OF PAVEMENT
SW	SWALE	▲	FOUND MONUMENT
HP	HINGE POINT	⊥	SIGN
TOE	TOE OF SLOPE	⊞	WATER METER
C	TOP OF CONCRETE	TOR	TOP OF RAIL
EG	EDGE OF GRAVEL		
●	MANHOLE		
○	EXISTING GROUND ELEVATION		
⊙	DECIDUOUS TREE		
⊙	EVERGREEN TREE		
GR	GRAVEL		
⊕	POWER POLE		

**REDUCED**  
 APPROXIMATELY HALF-SCALE

THE EXISTING UNDERGROUND UTILITY LINES SHOWN ARE BASED ON THE LOCATION OF VISIBLE SURFACE IMPROVEMENTS AND BASEMAPS. ALTHOUGH EVERY EFFORT HAS BEEN MADE TO ACCURATELY SHOW THE UNDERGROUND UTILITY LINES, IT WILL BE NECESSARY TO CONFIRM THE LOCATIONS BY CALLING 1-800-332-2344 FOR UTILITY LOCATIONS PRIOR TO DIGGING.

NO.	DATE	REVISIONS

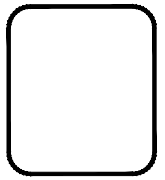

**CITY OF THE DALLES**  
 PUBLIC WORKS DEPARTMENT  
 1215 West First Street  
 The Dalles, Oregon 97058  
 (541) 296-5401

A TOPOGRAPHIC SURVEY FOR:  
**WESTSIDE INTERCEPTOR  
 UPGRADES - PHASE 2**  
 THE DALLES, OREGON

NAME	MHB
DATE	02/14/2024
SCALE	1"=20'
CHECKED	
SHEET	
<b>C14</b>	
OF	31 SHEETS
JOB NO.	2025-010

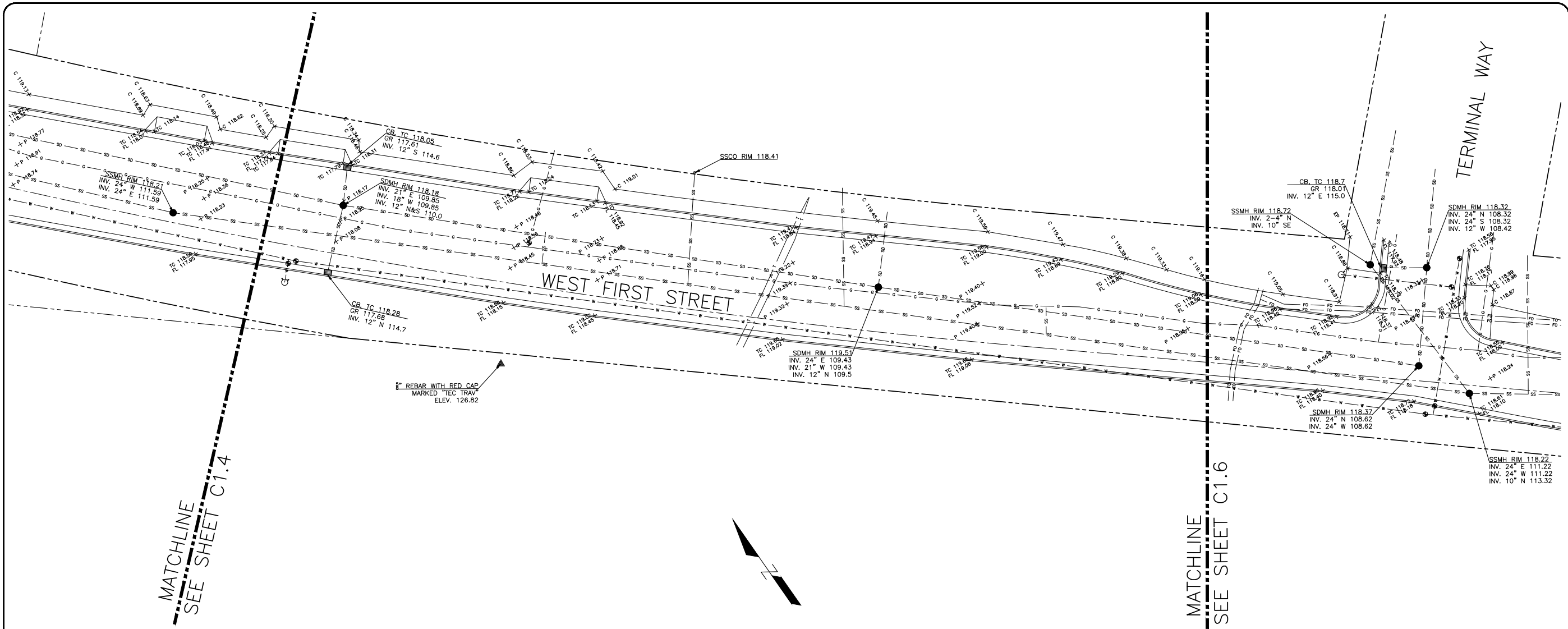

### LEGEND

FL	FLOWLINE	⊗	WATER VALVE, UNLESS NOTED OTHERWISE
TC	TOP OF CURB	⊙	FIRE HYDRANT
P	TOP OF PAVEMENT	EP	EDGE OF PAVEMENT
SW	SWALE	▲	FOUND MONUMENT
HP	HINGE POINT	⊖	SIGN
TOE	TOE OF SLOPE	⊞	WATER METER
C	TOP OF CONCRETE	TOR	TOP OF RAIL
EG	EDGE OF GRAVEL		
●	MANHOLE		
○	EXISTING GROUND ELEVATION		
⊙	DECIDUOUS TREE		
⊙	EVERGREEN TREE		
GR	GRAVEL		
⊕	POWER POLE		

**REDUCED**  
 APPROXIMATELY HALF-SCALE

THE EXISTING UNDERGROUND UTILITY LINES SHOWN ARE BASED ON THE LOCATION OF VISIBLE SURFACE IMPROVEMENTS AND BASEMAPS. ALTHOUGH EVERY EFFORT HAS BEEN MADE TO ACCURATELY SHOW THE UNDERGROUND UTILITY LINES, IT WILL BE NECESSARY TO CONFIRM THE LOCATIONS BY CALLING 1-800-332-2344 FOR UTILITY LOCATIONS PRIOR TO DIGGING.

NO.	DATE	REVISIONS

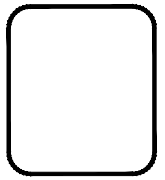

**CITY OF THE DALLES**  
 PUBLIC WORKS DEPARTMENT  
 1215 West First Street  
 The Dalles, Oregon 97058  
 (541) 296-5401



A TOPOGRAPHIC SURVEY FOR:  
**WESTSIDE INTERCEPTOR  
 UPGRADES - PHASE 2**  
 THE DALLES, OREGON

NAME	MHB
DATE	02/14/2024
SCALE	1"=20'
CHECKED	
SHEET	<b>C15</b>
OF	31 SHEETS
JOB NO.	2025-010

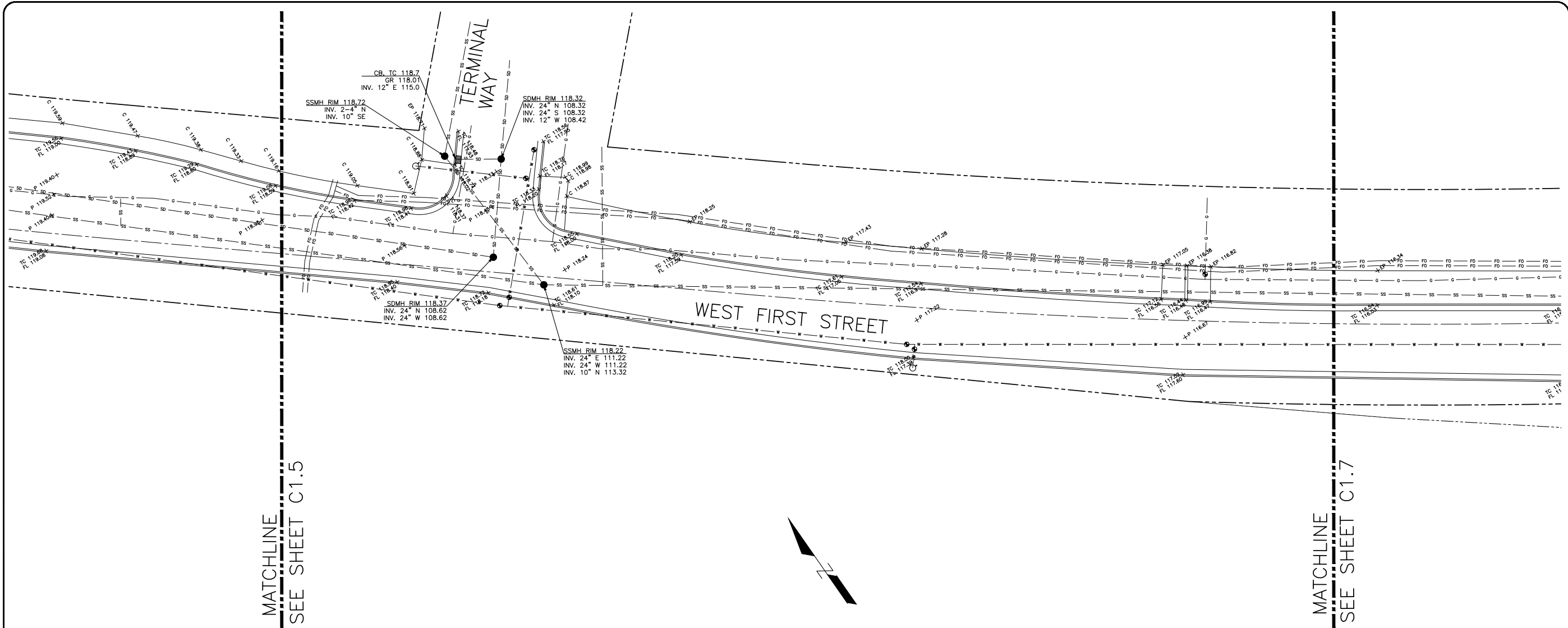

### LEGEND

FL	FLOWLINE	⊗	WATER VALVE, UNLESS NOTED OTHERWISE
TC	TOP OF CURB	⊙	FIRE HYDRANT
P	TOP OF PAVEMENT	EP	EDGE OF PAVEMENT
SW	SWALE	▲	FOUND MONUMENT
HP	HINGE POINT	⊖	SIGN
TOE	TOE OF SLOPE	⊞	WATER METER
C	TOP OF CONCRETE	TOR	TOP OF RAIL
EG	EDGE OF GRAVEL		
●	MANHOLE		
⊙	EXISTING GROUND ELEVATION		
⊙	DECIDUOUS TREE		
⊙	EVERGREEN TREE		
GR	GRAVEL		
⊕	POWER POLE		

**REDUCED**  
 APPROXIMATELY HALF-SCALE

THE EXISTING UNDERGROUND UTILITY LINES SHOWN ARE BASED ON THE LOCATION OF VISIBLE SURFACE IMPROVEMENTS AND BASEMAPS. ALTHOUGH EVERY EFFORT HAS BEEN MADE TO ACCURATELY SHOW THE UNDERGROUND UTILITY LINES, IT WILL BE NECESSARY TO CONFIRM THE LOCATIONS BY CALLING 1-800-332-2344 FOR UTILITY LOCATIONS PRIOR TO DIGGING.

NO.	DATE	REVISIONS

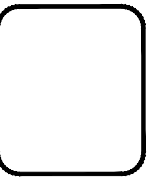

**CITY OF THE DALLES**  
 PUBLIC WORKS DEPARTMENT  
 1215 West First Street  
 The Dalles, Oregon 97058  
 (541) 296-5401

A TOPOGRAPHIC SURVEY FOR:  
**WESTSIDE INTERCEPTOR  
 UPGRADES - PHASE 2**  
 THE DALLES, OREGON

NAME	MHB
DATE	02/14/2024
SCALE	1"=20'
CHECKED	
SHEET	
<b>C16</b>	
OF	31 SHEETS
JOB NO.	2025-010

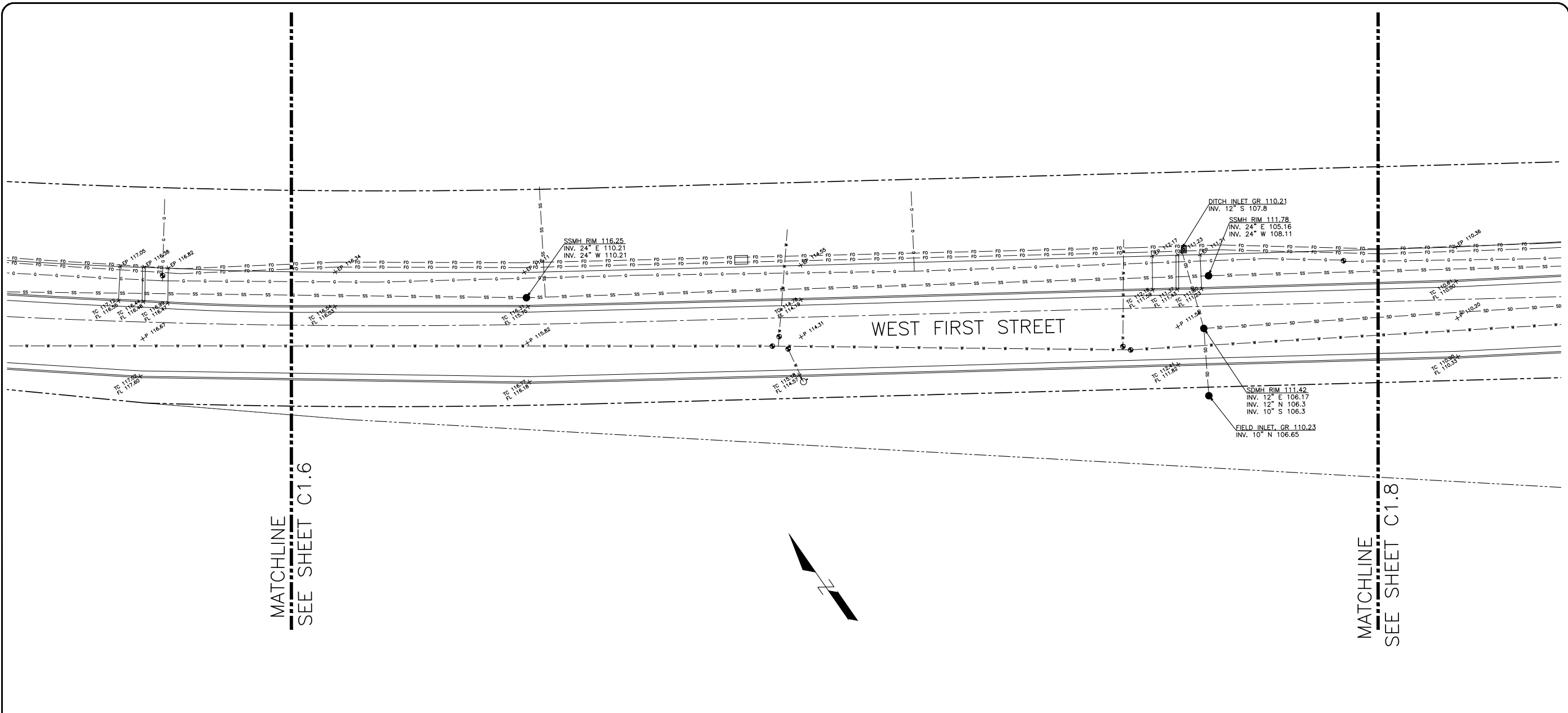

### LEGEND

FL	FLOWLINE	⊗	WATER VALVE, UNLESS NOTED OTHERWISE
TC	TOP OF CURB	⊙	FIRE HYDRANT
P	TOP OF PAVEMENT	EP	EDGE OF PAVEMENT
SW	SWALE	▲	FOUND MONUMENT
HP	HINGE POINT	⊥	SIGN
TOE	TOE OF SLOPE	⊞	WATER METER
C	TOP OF CONCRETE	TOR	TOP OF RAIL
EG	EDGE OF GRAVEL		
●	MANHOLE		
⊙	EXISTING GROUND ELEVATION		
⊙	DECIDUOUS TREE		
⊙	EVERGREEN TREE		
GR	GRAVEL		
⊙	POWER POLE		

**REDUCED**  
 APPROXIMATELY HALF-SCALE

THE EXISTING UNDERGROUND UTILITY LINES SHOWN ARE BASED ON THE LOCATION OF VISIBLE SURFACE IMPROVEMENTS AND BASEMAPS. ALTHOUGH EVERY EFFORT HAS BEEN MADE TO ACCURATELY SHOW THE UNDERGROUND UTILITY LINES, IT WILL BE NECESSARY TO CONFIRM THE LOCATIONS BY CALLING 1-800-332-2344 FOR UTILITY LOCATIONS PRIOR TO DIGGING.

NO.	DATE	REVISIONS

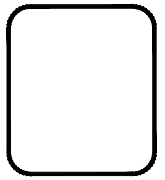

**CITY OF THE DALLES**  
 PUBLIC WORKS DEPARTMENT  
 1215 West First Street  
 The Dalles, Oregon 97058  
 (541) 296-5401

A TOPOGRAPHIC SURVEY FOR:  
**WESTSIDE INTERCEPTOR  
 UPGRADES - PHASE 2**  
 THE DALLES, OREGON

NAME	MHB
DATE	02/14/2024
SCALE	1"=20'
CHECKED	
SHEET	<b>C17</b>
OF	31 SHEETS
JOB NO.	2025-010

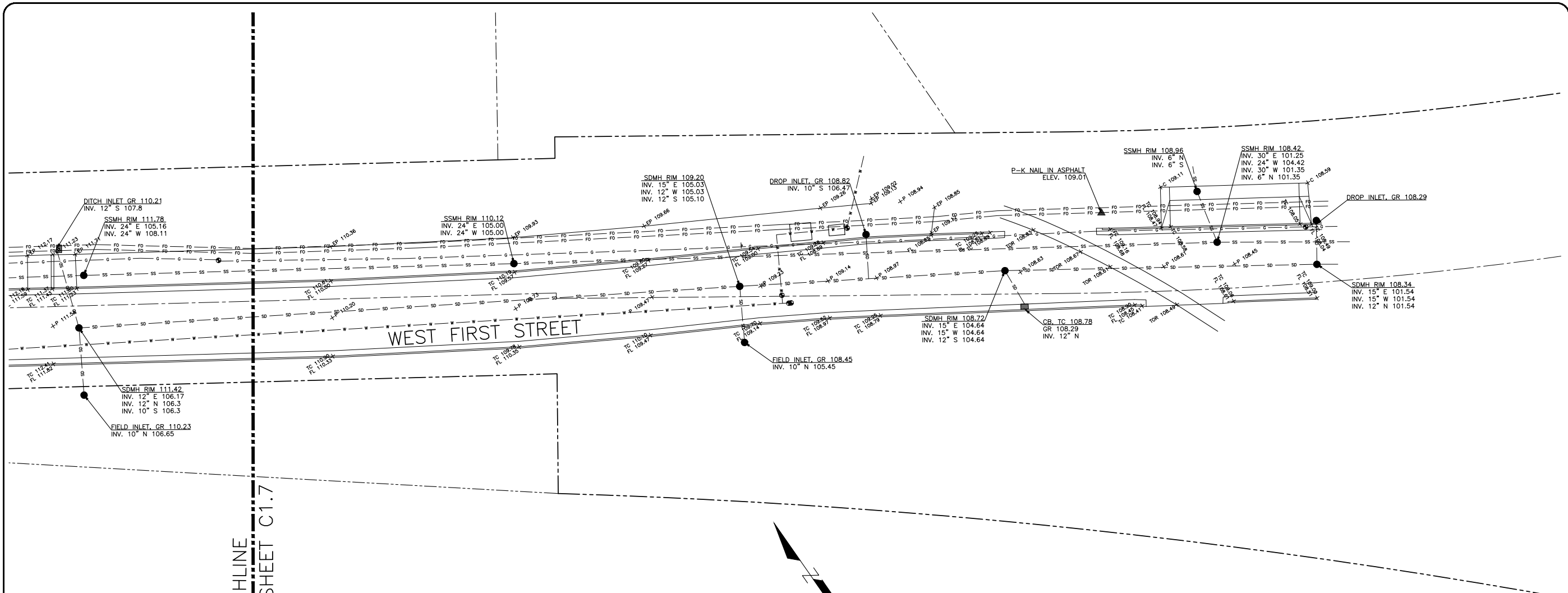

MATCHLINE  
SEE SHEET C1.7

### LEGEND

FL	FLOWLINE	⊗	WATER VALVE, UNLESS NOTED OTHERWISE
TC	TOP OF CURB	⊙	FIRE HYDRANT
P	TOP OF PAVEMENT	EP	EDGE OF PAVEMENT
SW	SWALE	▲	FOUND MONUMENT
HP	HINGE POINT	⊥	SIGN
TOE	TOE OF SLOPE	⊞	WATER METER
C	TOP OF CONCRETE	TOR	TOP OF RAIL
EG	EDGE OF GRAVEL		
●	MANHOLE		
⊙	EXISTING GROUND ELEVATION		
⊙	DECIDUOUS TREE		
⊙	EVERGREEN TREE		
GR	GRAVEL		
⊙	POWER POLE		

**REDUCED**  
APPROXIMATELY HALF-SCALE

THE EXISTING UNDERGROUND UTILITY LINES SHOWN ARE BASED ON THE LOCATION OF VISIBLE SURFACE IMPROVEMENTS AND BASEMAPS. ALTHOUGH EVERY EFFORT HAS BEEN MADE TO ACCURATELY SHOW THE UNDERGROUND UTILITY LINES, IT WILL BE NECESSARY TO CONFIRM THE LOCATIONS BY CALLING 1-800-332-2344 FOR UTILITY LOCATIONS PRIOR TO DIGGING.

NO.	DATE	REVISIONS

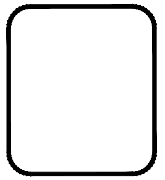

**CITY OF THE DALLES**  
PUBLIC WORKS DEPARTMENT  
1215 West First Street  
The Dalles, Oregon 97058  
(541) 296-5401



A TOPOGRAPHIC SURVEY FOR:  
**WESTSIDE INTERCEPTOR  
UPGRADES - PHASE 2**  
THE DALLES, OREGON

NAME	MHB
DATE	02/14/2024
SCALE	1"=20'
CHECKED	
SHEET	<b>C18</b>
OF	31 SHEETS
JOB NO.	2025-01

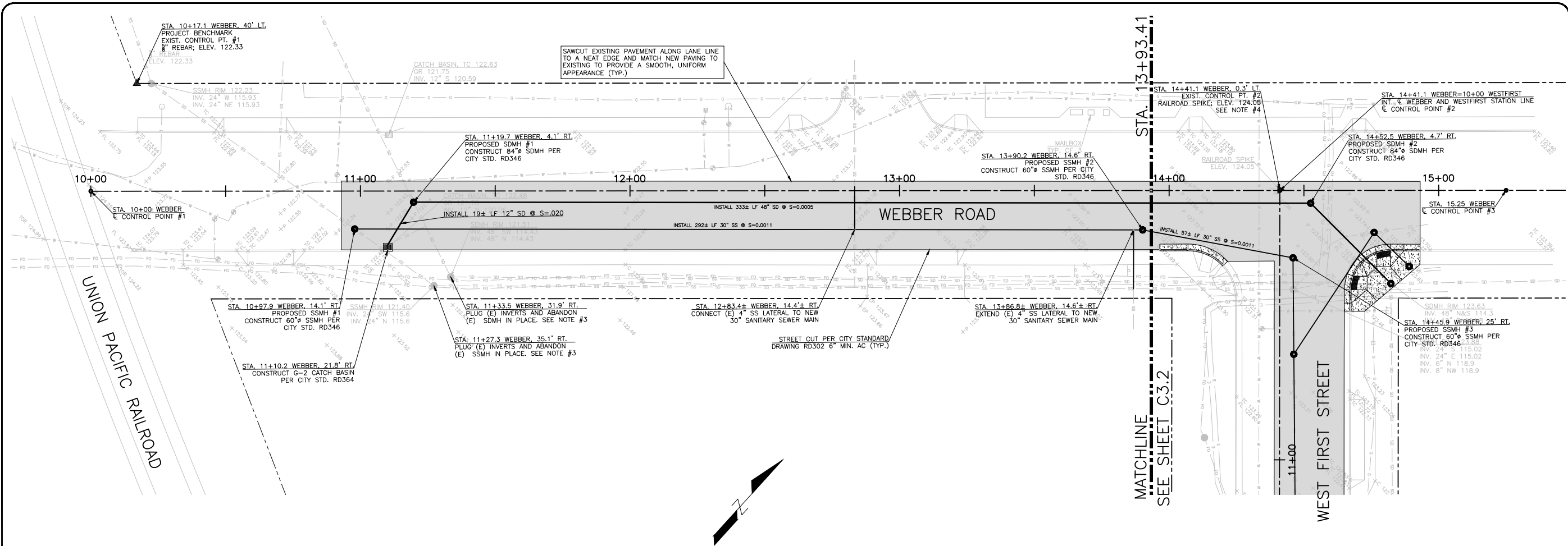

**CENTERLINE COODINATE CONTROL**

CONTROL PT. #	NORTHING	EASTING	DESCRIPTION
1	709812.20	8022611.85	CALCULATED POINT
2	710108.61	8022938.48	℄ INT. W. FIRST AND WEBBER
3	710165.01	8023000.63	CALCULATED POINT
4	709255.08	8023710.33	BEGIN CURVE
5	708978.48	8023997.93	END CURVE
6	708887.89	8024106.32	℄ INT. WESTFIRST AND TERMINAL
7	708891.73	8024109.53	℄ INT. EASTFIRST AND TERMINAL
8	708858.51	8024141.61	POINT OF REVERSE CURVATURE
9	708811.65	8024189.08	POINT OF COMPOUND CURVATURE
10	708616.38	8024447.98	END CURVE
11	708444.66	8024708.93	BEGIN CURVE
12	708378.10	8024820.27	POINT OF REVERSE CURVATURE
13	708316.18	8024924.53	END CURVE
14	708243.43	8025036.45	CALCULATED POINT

**NOTES**

- SEE SHEET C0.1 FOR GENERAL NOTES AND INFORMATION.
- SEE SHEET C5.1 FOR GRADING PLAN.
- EXISTING MANHOLES TO BE ABANDONED IN PLACE SHALL HAVE PIPE OPENINGS PLUGGED WITH GROUT OR MECHANICAL MEANS, CONE AND FRAME REMOVED, BOTTOM OF STRUCTURE DEMOLISHED, AND BACKFILLED WITH STRUCTURAL FILL.
- RAILROAD SPIKE IS AN EXISTING SURVEY MONUMENT. MONUMENT SHALL BE RE-SET BY A LICENSED SURVEYOR IF DISTURBED OR DESTROYED AT NO COST TO THE CITY.

**BENCHMARK**

PROJECT BENCHMARK: 5/8" REBAR AT SOUTHWEST INTERSECTION OF WEBBER STREET  
 RIGHT OF WAY AND UNION PACIFIC RIGHT OF WAY  
 NORTHING: 709853.28 EASTING: 8022597.61 ELEV. 122.33

**REDUCED**  
 APPROXIMATELY HALF-SCALE

NO.	DATE	REVISIONS



**CITY OF THE DALLES**  
 PUBLIC WORKS DEPARTMENT  
 1215 West First Street  
 The Dalles, Oregon 97058  
 (541) 296-5401



A LAYOUT PLAN FOR:  
**WESTSIDE INTERCEPTOR  
 UPGRADES - PHASE 2**  
 THE DALLES, OREGON

NAME	MHB
DATE	9/2/2025
SCALE	1"=20'
CHECKED	
SHEET	<b>C3.1</b>
OF	31 SHEETS
JOB NO.	2025-010

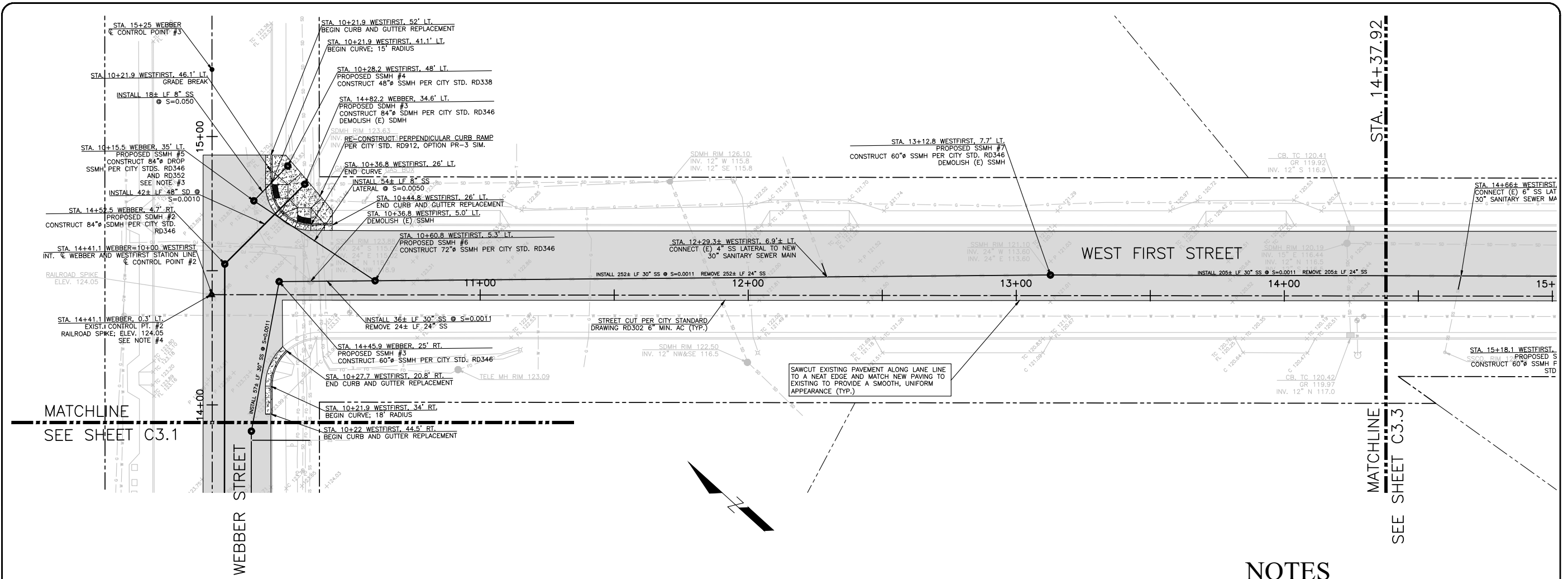

MATCHLINE  
SEE SHEET C3.1

MATCHLINE  
SEE SHEET C3.3

CENTERLINE COODINATE CONTROL

CONTROL PT. #	NORTHING	EASTING	DESCRIPTION
1	709812.20	8022611.85	CALCULATED POINT
2	710108.61	8022938.48	℄ INT. W. FIRST AND WEBBER
3	710165.01	8023000.63	CALCULATED POINT
4	709255.08	8023710.33	BEGIN CURVE
5	708978.48	8023997.93	END CURVE
6	708887.89	8024106.32	℄ INT. WESTFIRST AND TERMINAL
7	708891.73	8024109.53	℄ INT. EASTFIRST AND TERMINAL
8	708858.51	8024141.61	POINT OF REVERSE CURVATURE
9	708811.65	8024189.08	POINT OF COMPOUND CURVATURE
10	708616.38	8024447.98	END CURVE
11	708444.66	8024708.93	BEGIN CURVE
12	708378.10	8024820.27	POINT OF REVERSE CURVATURE
13	708316.18	8024924.53	END CURVE
14	708243.43	8025036.45	CALCULATED POINT

NOTES

- SEE SHEET C0.1 FOR GENERAL NOTES AND INFORMATION.
- SEE SHEET C5.2 FOR GRADING PLAN.
- PROPOSED SSMH #5 SHALL BE CONSTRUCTED WITH AN OUTSIDE DROP FOR THE NEW 8" SS AND AN INSIDE DROP FOR THE (E) 8" FORCE MAIN.
- RAILROAD SPIKE IS AN EXISTING SURVEY MONUMENT. MONUMENT SHALL BE RE-SET BY A LICENSED SURVEYOR IF DISTURBED OR DESTROYED AT NO COST TO THE CITY.

BENCHMARK

PROJECT BENCHMARK: 5/8" REBAR AT SOUTHWEST INTERSECTION OF WEBBER STREET  
RIGHT OF WAY AND UNION PACIFIC RIGHT OF WAY  
NORTHING: 709853.28 EASTING: 802297.61 ELEV. 122.33

**REDUCED**  
APPROXIMATELY HALF-SCALE

NO.	DATE	REVISIONS



**CITY OF THE DALLES**  
PUBLIC WORKS DEPARTMENT  
1215 West First Street  
The Dalles, Oregon 97058  
(541) 296-5401



A LAYOUT PLAN FOR:  
**WESTSIDE INTERCEPTOR  
UPGRADES - PHASE 2**  
THE DALLES, OREGON

NAME	MHB
DATE	9/2/2025
SCALE	1"=20'
CHECKED	
SHEET	<b>C3.2</b>
OF	31 SHEETS
JOB NO.	2025.010

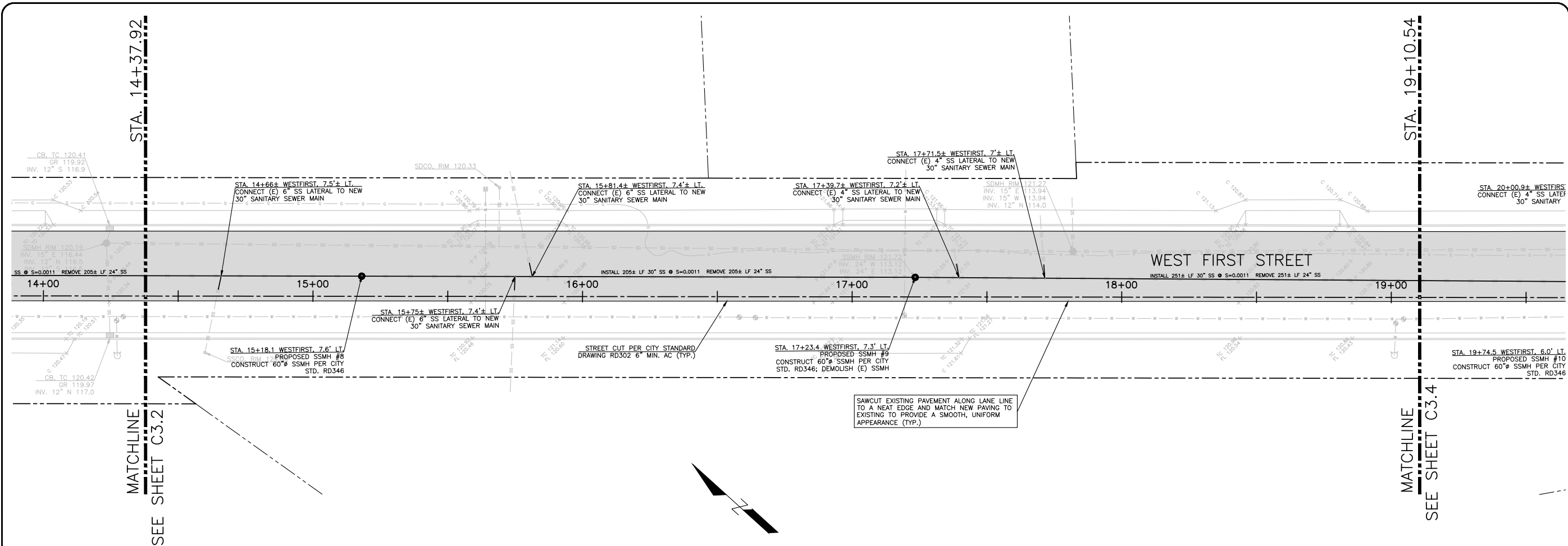

NO.	DATE	REVISIONS



**CITY OF THE DALLES**  
 PUBLIC WORKS DEPARTMENT  
 1215 West First Street  
 The Dalles, Oregon 97058  
 (541) 296-5401



A LAYOUT PLAN FOR:  
**WESTSIDE INTERCEPTOR  
 UPGRADES - PHASE 2**  
 THE DALLES, OREGON

NAME	MHB
DATE	9/2/2025
SCALE	1"=20'
CHECKED	
SHEET	<b>C3.3</b>
OF	31 SHEETS
JOB NO.	2025-010

CENTERLINE COODINATE CONTROL

CONTROL PT. #	NORTHING	EASTING	DESCRIPTION
1	709812.20	8022611.85	CALCULATED POINT
2	710108.61	8022938.48	⊙ INT. W. FIRST AND WEBBER
3	710165.01	8023000.63	CALCULATED POINT
4	709255.08	8023710.33	BEGIN CURVE
5	708978.48	8023997.93	END CURVE
6	708887.89	8024106.32	⊙ INT. WESTFIRST AND TERMINAL
7	708891.73	8024109.53	⊙ INT. EASTFIRST AND TERMINAL
8	708858.51	8024141.61	POINT OF REVERSE CURVATURE
9	708811.65	8024189.08	POINT OF COMPOUND CURVATURE
10	708616.38	8024447.98	END CURVE
11	708444.66	8024708.93	BEGIN CURVE
12	708378.10	8024820.27	POINT OF REVERSE CURVATURE
13	708316.18	8024924.53	END CURVE
14	708243.43	8025036.45	CALCULATED POINT

SAWCUT EXISTING PAVEMENT ALONG LANE LINE TO A NEAT EDGE AND MATCH NEW PAVING TO EXISTING TO PROVIDE A SMOOTH, UNIFORM APPEARANCE (TYP.)

**NOTES**

- SEE SHEET C0.1 FOR GENERAL NOTES AND INFORMATION.
- SEE SHEET C5.3 FOR GRADING PLAN.

BENCHMARK

PROJECT BENCHMARK: 5/8" REBAR AT SOUTHWEST INTERSECTION OF WEBBER STREET RIGHT OF WAY AND UNION PACIFIC RIGHT OF WAY  
 NORTHING: 709853.28 EASTING: 802297.61 ELEV. 122.33

**REDUCED**  
 APPROXIMATELY HALF-SCALE

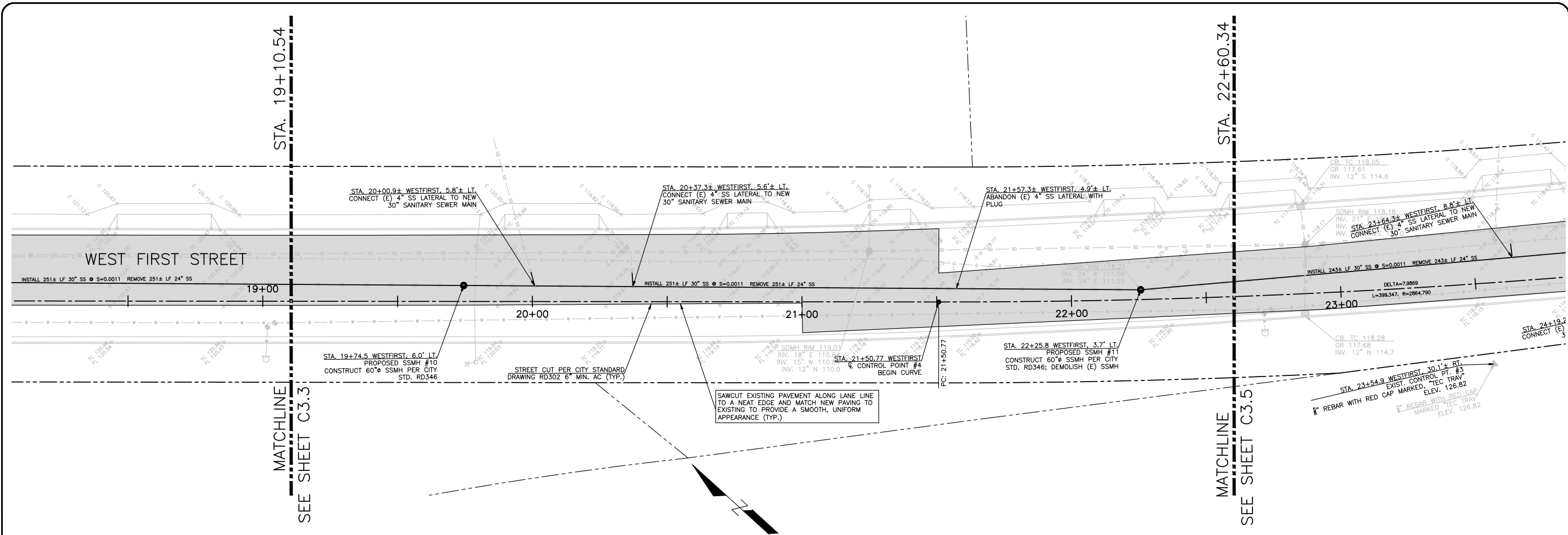

NO.	DATE	REVISIONS



**CITY OF THE DALLES**  
 PUBLIC WORKS DEPARTMENT  
 1215 West First Street  
 The Dalles, Oregon 97058  
 (541) 296-5401

### NOTES

- SEE SHEET C0.1 FOR GENERAL NOTES AND INFORMATION.
- SEE SHEET C5.4 FOR GRADING PLAN.

### BENCHMARK

PROJECT BENCHMARK: 5/8" REBAR AT SOUTHWEST INTERSECTION OF WEBBER STREET  
 RIGHT OF WAY AND UNION PACIFIC RIGHT OF WAY  
 NORTHING: 709653.28 EASTING: 802297.61 ELEV. 122.33

### CENTERLINE COODINATE CONTROL

CONTROL PT. #	NORTHING	EASTING	DESCRIPTION
1	709812.20	8022611.85	CALCULATED POINT
2	710108.61	8022938.48	℄ INT. W. FIRST AND WEBBER
3	710165.01	8023000.63	CALCULATED POINT
4	709255.08	8023710.33	BEGIN CURVE
5	708978.48	8023997.93	END CURVE
6	708887.89	8024106.32	℄ INT. WESTFIRST AND TERMINAL
7	708891.73	8024109.53	℄ INT. EASTFIRST AND TERMINAL
8	708858.51	8024141.61	POINT OF REVERSE CURVATURE
9	708811.65	8024189.08	POINT OF COMPOUND CURVATURE
10	708616.38	8024447.98	END CURVE
11	708444.66	8024708.93	BEGIN CURVE
12	708378.10	8024820.27	POINT OF REVERSE CURVATURE
13	708316.18	8024924.53	END CURVE
14	708243.43	8025036.45	CALCULATED POINT

**REDUCED**  
 APPROXIMATELY HALF-SCALE

A LAYOUT PLAN FOR:  
**WESTSIDE INTERCEPTOR  
 UPGRADES - PHASE 2**  
 THE DALLES, OREGON

NAME	MHB
DATE	9/2/2025
SCALE	1"=20'
CHECKED	
SHEET	<b>C3.4</b>
OF	31 SHEETS
JOB NO.	2025-010

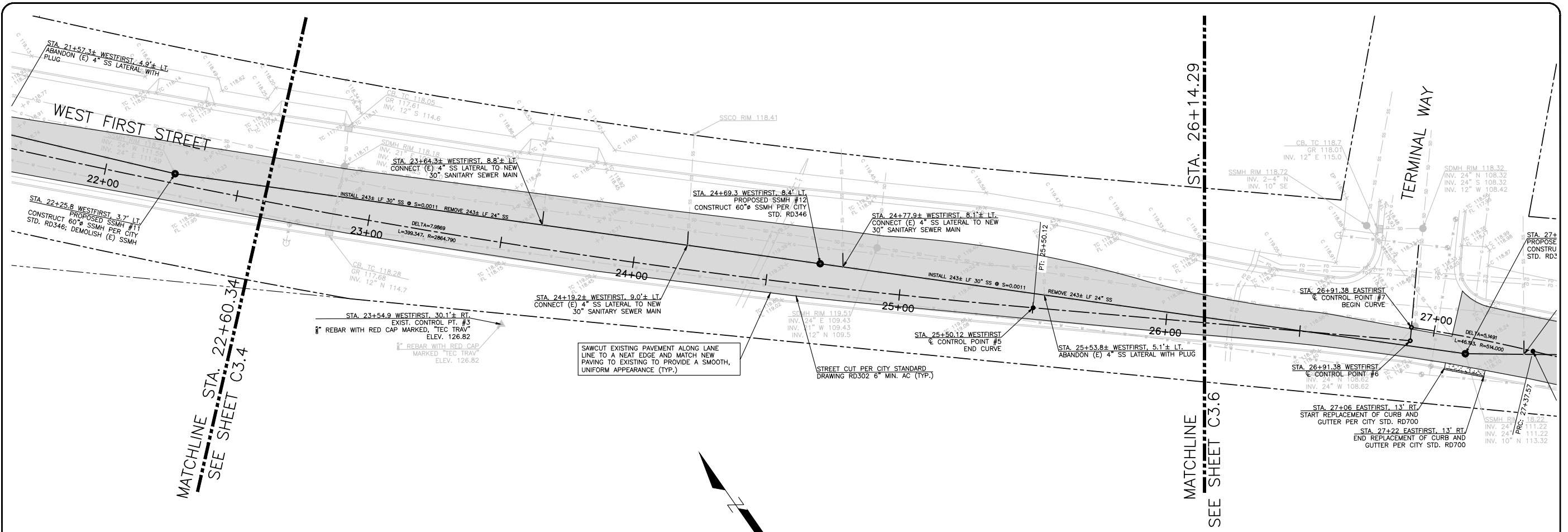

MATCHLINE STA. 22+60.34  
SEE SHEET C3.4

MATCHLINE STA. 26+14.29  
SEE SHEET C3.6

SAWCUT EXISTING PAVEMENT ALONG LANE LINE TO A NEAT EDGE AND MATCH NEW PAVING TO EXISTING TO PROVIDE A SMOOTH, UNIFORM APPEARANCE (TYP.)

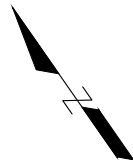

**CENTERLINE COODINATE CONTROL**

CONTROL PT. #	NORTHING	EASTING	DESCRIPTION
1	709812.20	8022611.85	CALCULATED POINT
2	710108.61	8022938.48	☉ INT. W. FIRST AND WEBBER
3	710165.01	8023000.63	CALCULATED POINT
4	709255.08	8023710.33	BEGIN CURVE
5	708978.48	8023997.93	END CURVE
6	708887.89	8024106.32	☉ INT. WESTFIRST AND TERMINAL
7	708891.73	8024109.53	☉ INT. EASTFIRST AND TERMINAL
8	708858.51	8024141.61	POINT OF REVERSE CURVATURE
9	708811.65	8024189.08	POINT OF COMPOUND CURVATURE
10	708616.38	8024447.98	END CURVE
11	708444.66	8024708.93	BEGIN CURVE
12	708378.10	8024820.27	POINT OF REVERSE CURVATURE
13	708316.18	8024924.53	END CURVE
14	708243.43	8025036.45	CALCULATED POINT

**NOTES**

- SEE SHEET C0.1 FOR GENERAL NOTES AND INFORMATION.
- SEE SHEET C5.5 FOR GRADING PLAN.

**BENCHMARK**

PROJECT BENCHMARK: 5/8" REBAR AT SOUTHWEST INTERSECTION OF WEBBER STREET RIGHT OF WAY AND UNION PACIFIC RIGHT OF WAY  
NORTHING: 709853.28 EASTING: 802297.61 ELEV. 122.33

**REDUCED**  
APPROXIMATELY HALF-SCALE

NO.	DATE	REVISIONS



**CITY OF THE DALLES**  
PUBLIC WORKS DEPARTMENT  
1215 West First Street  
The Dalles, Oregon 97058  
(541) 296-5401



A LAYOUT PLAN FOR:  
**WESTSIDE INTERCEPTOR  
UPGRADES - PHASE 2**  
THE DALLES, OREGON

NAME	MHB
DATE	9/2/2025
SCALE	1"=20'
CHECKED	
SHEET	<b>C3.5</b>
OF	31 SHEETS
JOB NO.	2025-010

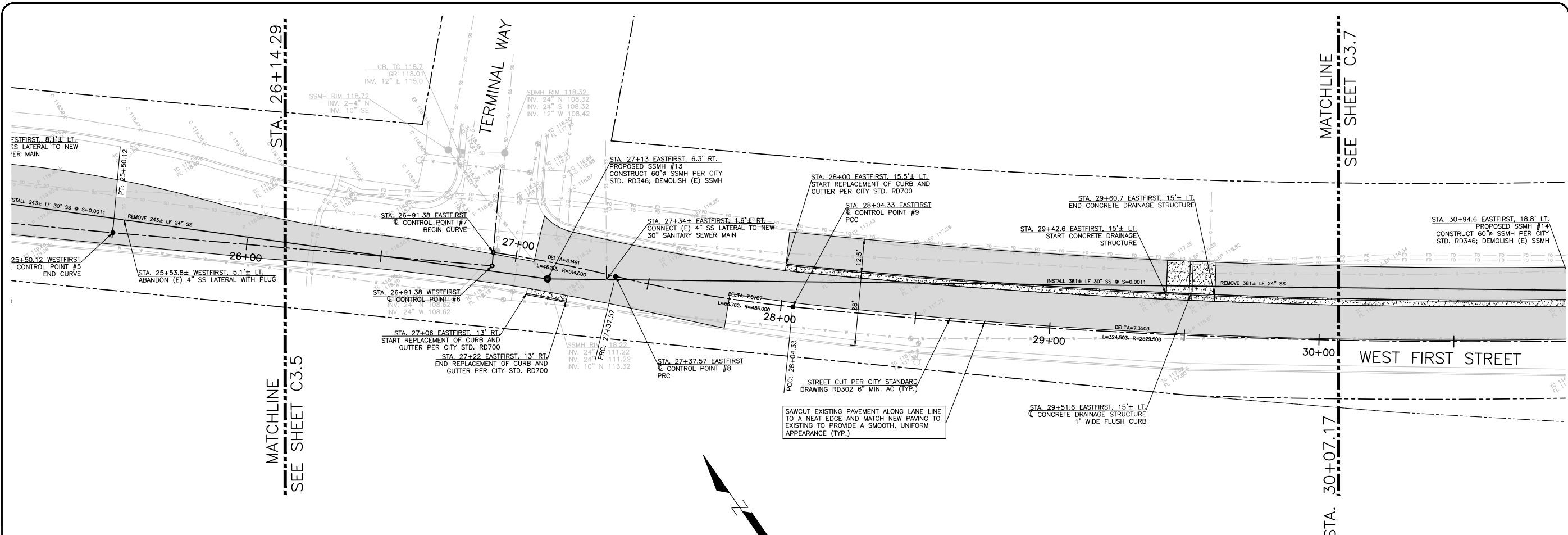

MATCHLINE  
SEE SHEET C3.5  
STA. 26+14.29

MATCHLINE  
SEE SHEET C3.7  
STA. 30+07.17

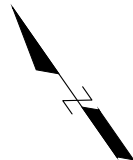

CENTERLINE COODINATE CONTROL

CONTROL PT. #	NORTHING	EASTING	DESCRIPTION
1	709812.20	8022611.85	CALCULATED POINT
2	710108.61	8022938.48	INT. W. FIRST AND WEBBER
3	710165.01	8023000.63	CALCULATED POINT
4	709255.08	8023710.33	BEGIN CURVE
5	708978.48	8023997.93	END CURVE
6	708887.89	8024106.32	INT. WESTFIRST AND TERMINAL
7	708891.73	8024109.53	INT. EASTFIRST AND TERMINAL
8	708858.51	8024141.61	POINT OF REVERSE CURVATURE
9	708811.65	8024189.08	POINT OF COMPOUND CURVATURE
10	708616.38	8024447.98	END CURVE
11	708444.66	8024708.93	BEGIN CURVE
12	708378.10	8024820.27	POINT OF REVERSE CURVATURE
13	708316.18	8024924.53	END CURVE
14	708243.43	8025036.45	CALCULATED POINT

**NOTES**

- SEE SHEET C0.1 FOR GENERAL NOTES AND INFORMATION.
- SEE SHEET C5.6 FOR GRADING PLAN.

BENCHMARK

PROJECT BENCHMARK: 5/8" REBAR AT SOUTHWEST INTERSECTION OF WEBBER STREET  
RIGHT OF WAY AND UNION PACIFIC RIGHT OF WAY  
NORTHING: 709853.28 EASTING: 802297.61 ELEV. 122.33

**REDUCED**  
APPROXIMATELY HALF-SCALE

NO.	DATE	REVISIONS



**CITY OF THE DALLES**  
PUBLIC WORKS DEPARTMENT  
1215 West First Street  
The Dalles, Oregon 97058  
(541) 296-5401

A LAYOUT PLAN FOR:  
**WESTSIDE INTERCEPTOR  
UPGRADES - PHASE 2**  
THE DALLES, OREGON

NAME	MHB
DATE	9/2/2025
SCALE	1"=20'
CHECKED	
SHEET	<b>C3.6</b>
OF	31 SHEETS
JOB NO.	2025-010

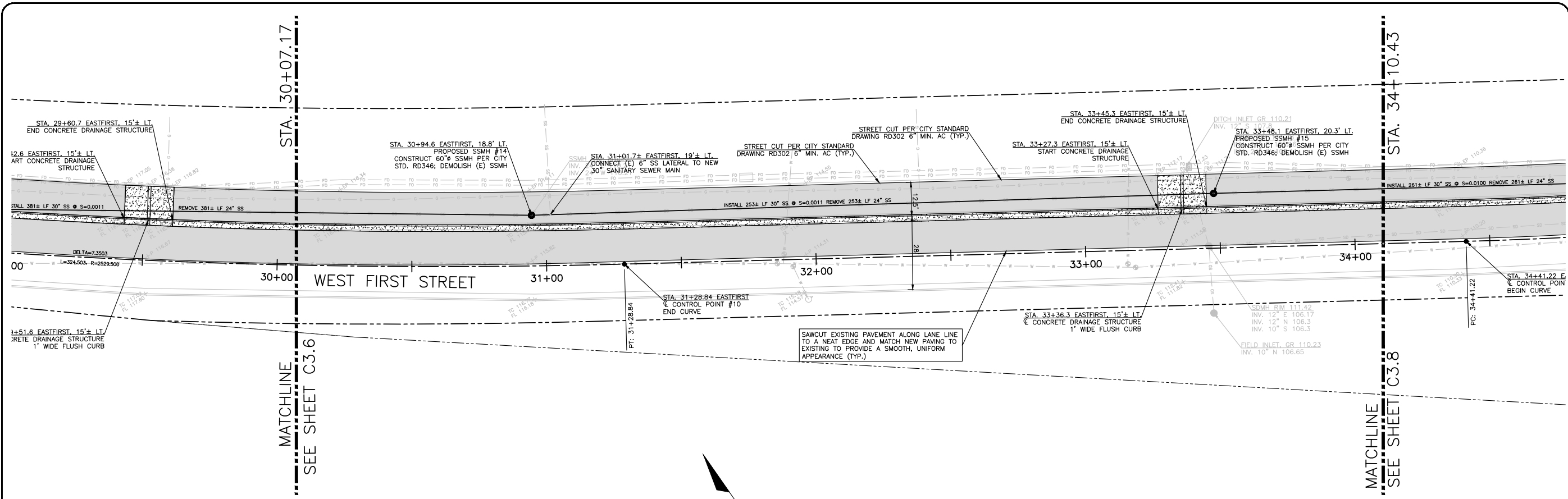

NO.	DATE	REVISIONS



**CITY OF THE DALLES**  
 PUBLIC WORKS DEPARTMENT  
 1215 West First Street  
 The Dalles, Oregon 97058  
 (541) 296-5401



A LAYOUT PLAN FOR:  
**WESTSIDE INTERCEPTOR  
 UPGRADES - PHASE 2**  
 THE DALLES, OREGON

NAME	MHB
DATE	9/2/2025
SCALE	1"=20'
CHECKED	
SHEET	C3.7
OF	31 SHEETS
JOB NO.	2025-010

### NOTES

- SEE SHEET C0.1 FOR GENERAL NOTES AND INFORMATION.
- SEE SHEET C5.7 FOR GRADING PLAN.

### BENCHMARK

PROJECT BENCHMARK: 5/8" REBAR AT SOUTHWEST INTERSECTION OF WEBBER STREET  
 RIGHT OF WAY AND UNION PACIFIC RIGHT OF WAY  
 NORTHING: 709653.28 EASTING: 802297.61 ELEV. 122.33

### CENTERLINE COODINATE CONTROL

CONTROL PT. #	NORTHING	EASTING	DESCRIPTION
1	709812.20	8022611.85	CALCULATED POINT
2	710108.61	8022938.48	☉ INT. W. FIRST AND WEBBER
3	710165.01	8023000.63	CALCULATED POINT
4	709255.08	8023710.33	BEGIN CURVE
5	708978.48	8023997.93	END CURVE
6	708887.89	8024106.32	☉ INT. WESTFIRST AND TERMINAL
7	708891.73	8024109.53	☉ INT. EASTFIRST AND TERMINAL
8	708858.51	8024141.61	POINT OF REVERSE CURVATURE
9	708811.65	8024189.08	POINT OF COMPOUND CURVATURE
10	708616.38	8024447.98	END CURVE
11	708444.66	8024708.93	BEGIN CURVE
12	708378.10	8024820.27	POINT OF REVERSE CURVATURE
13	708316.18	8024924.53	END CURVE
14	708243.43	8025036.45	CALCULATED POINT

**REDUCED**  
 APPROXIMATELY HALF-SCALE

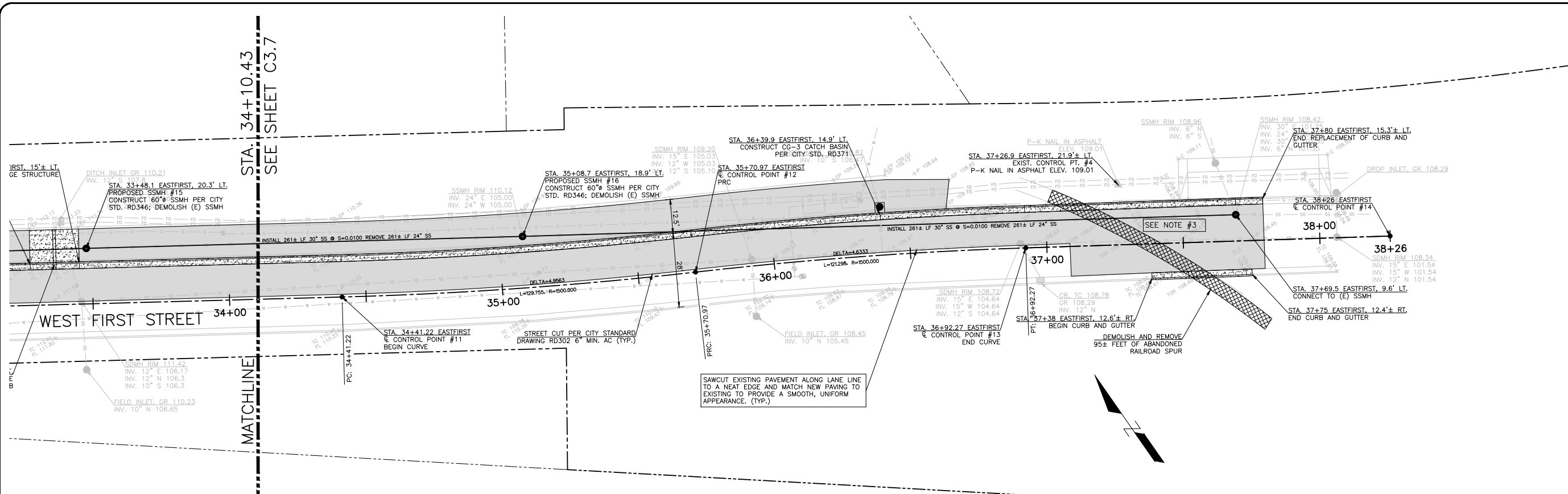

NO.	DATE	REVISIONS



**CITY OF THE DALLES**  
 PUBLIC WORKS DEPARTMENT  
 1215 West First Street  
 The Dalles, Oregon 97058  
 (541) 296-5401



A LAYOUT PLAN FOR:  
**WESTSIDE INTERCEPTOR  
 UPGRADES - PHASE 2**  
 THE DALLES, OREGON

NAME	MHB
DATE	9/2/2025
SCALE	1"=20'
CHECKED	
SHEET	<b>C3.8</b>
OF	31 SHEETS
JOB NO.	2025-010

**CENTERLINE COODINATE CONTROL**

CONTROL PT. #	NORTHING	EASTING	DESCRIPTION
1	709812.20	8022611.85	CALCULATED POINT
2	710108.61	8022938.48	☉ INT. W. FIRST AND WEBBER
3	710165.01	8023000.63	CALCULATED POINT
4	709255.08	8023710.33	BEGIN CURVE
5	708978.48	8023997.93	END CURVE
6	708887.89	8024106.32	☉ INT. WESTFIRST AND TERMINAL
7	708891.73	8024109.53	☉ INT. EASTFIRST AND TERMINAL
8	708858.51	8024141.61	POINT OF REVERSE CURVATURE
9	708811.65	8024189.08	POINT OF COMPOUND CURVATURE
10	708616.38	8024447.98	END CURVE
11	708444.66	8024708.93	BEGIN CURVE
12	708378.10	8024820.27	POINT OF REVERSE CURVATURE
13	708316.18	8024924.53	END CURVE
14	708243.43	8025036.45	CALCULATED POINT

**NOTES**

- SEE SHEET C0.1 FOR GENERAL NOTES AND INFORMATION.
- SEE SHEET C5.8 FOR GRADING PLAN.
- EXISTING 24" SANITARY SEWER LINE IS ENCASED IN CONCRETE PER CITY AS-BUILT DRAWINGS. ENCASEMENT TO BE DEMOLISHED AND REMOVED WITH PIPE.

**BENCHMARK**

PROJECT BENCHMARK: 5/8" REBAR AT SOUTHWEST INTERSECTION OF WEBBER STREET RIGHT OF WAY AND UNION PACIFIC RIGHT OF WAY  
 NORTHING: 709853.28 EASTING: 802297.61 ELEV. 122.33

**REDUCED**  
 APPROXIMATELY HALF-SCALE

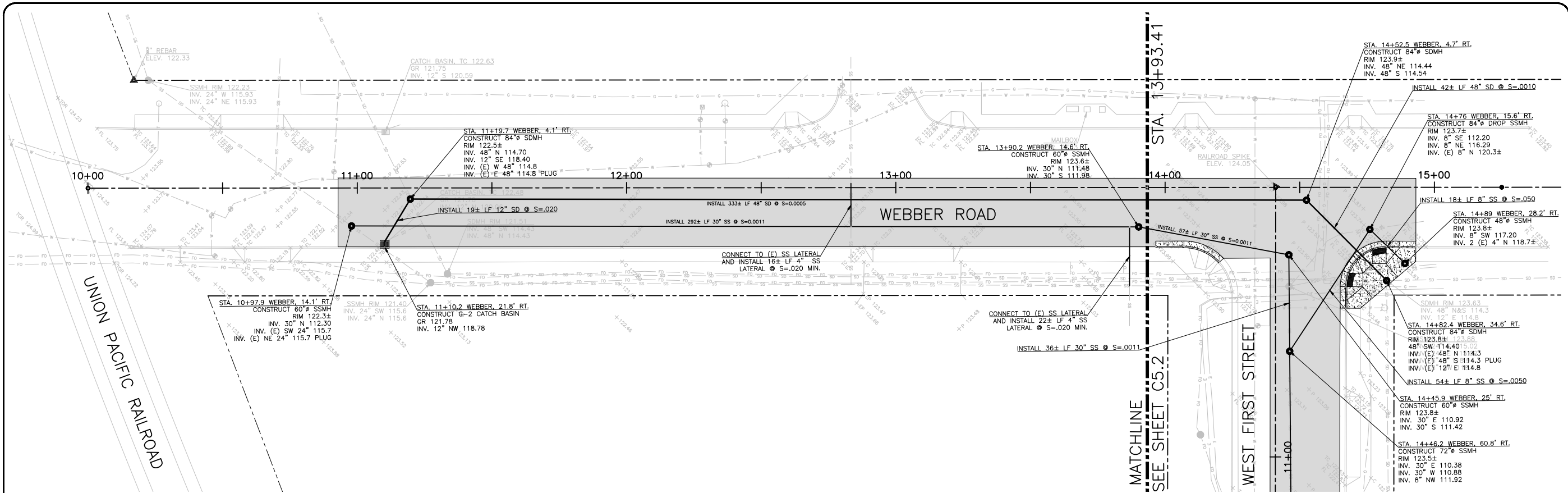

NO.	DATE	REVISIONS



**CITY OF THE DALLES**  
 PUBLIC WORKS DEPARTMENT  
 1215 West First Street  
 The Dalles, Oregon 97058  
 (541) 296-5401

SCALE  
 HORIZ. 1"=20'  
 VERT. 1"=4'

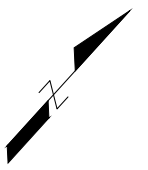

**NOTES**

- SEE SHEET C0.1 FOR GENERAL NOTES AND INFORMATION.
- SEE SHEET C3.1 FOR LAYOUT PLAN.
- EXISTING UTILITIES NOT SHOWN IN PROFILE FOR CLARITY.

**REDUCED**  
 APPROXIMATELY HALF-SCALE

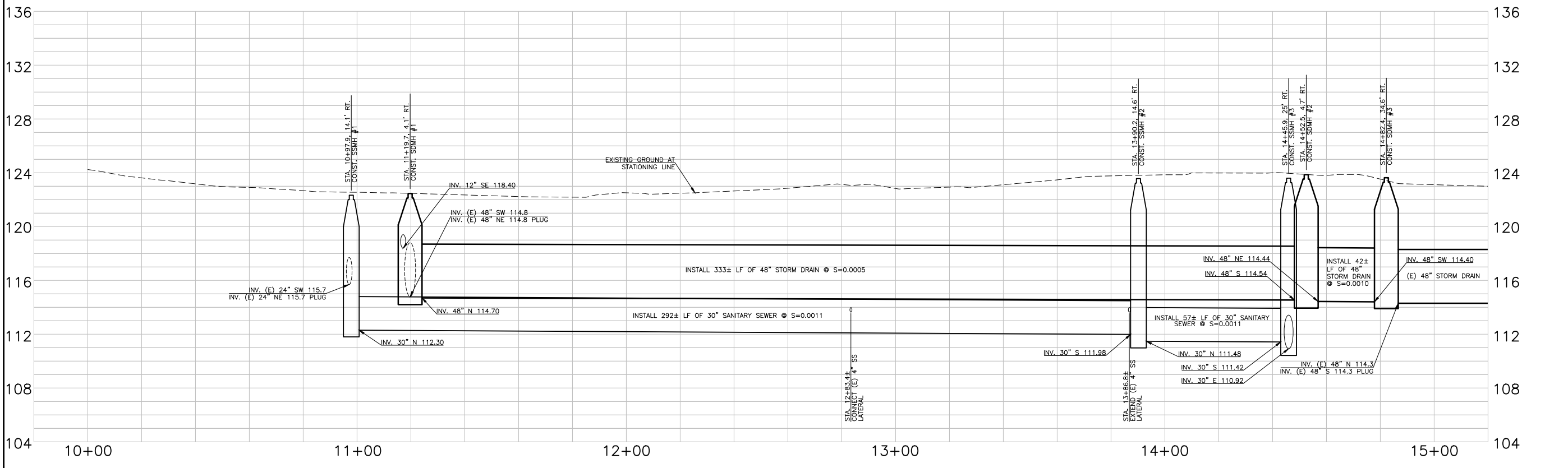

A PLAN AND PROFILE DRAWING FOR:  
**WESTSIDE INTERCEPTOR  
 UPGRADES - PHASE 2**  
 THE DALLES, OREGON

NAME	MHB
DATE	9/2/2025
SCALE	1"=20'
CHECKED	
SHEET	<b>C5.1</b>
OF	31 SHEETS
JOB NO.	2025-010

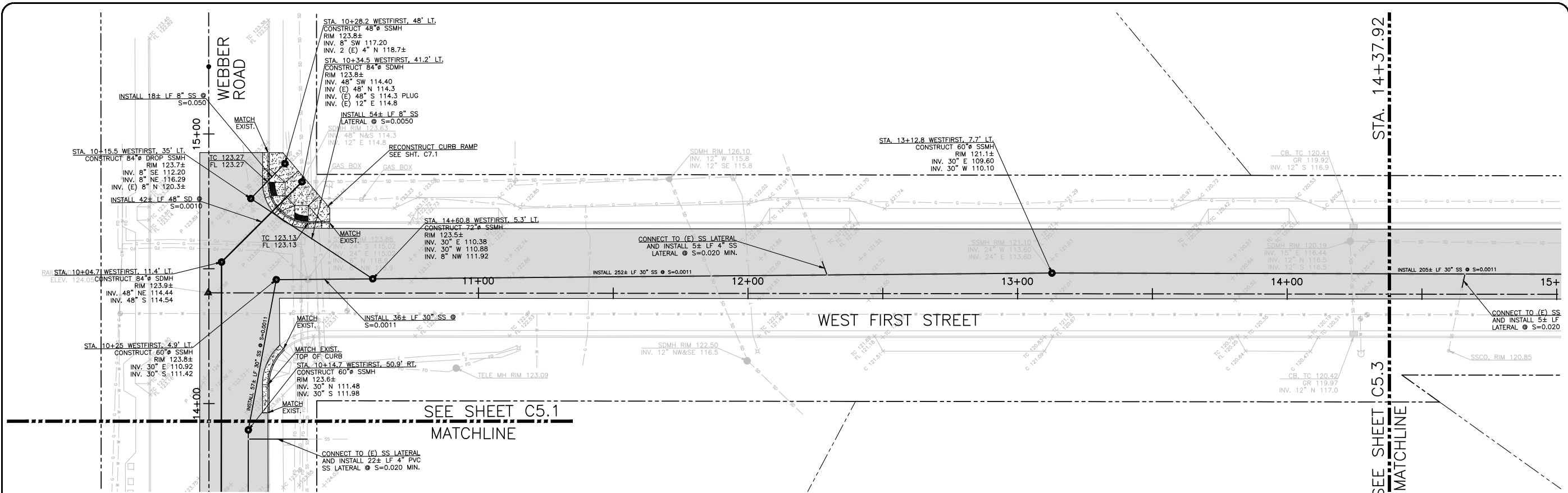

SCALE  
 HORIZ. 1"=20'  
 VERT. 1"=4'

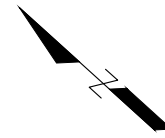

### NOTES

- SEE SHEET C0.1 FOR GENERAL NOTES AND INFORMATION.
- SEE SHEET C3.2 FOR LAYOUT PLAN.
- EXISTING UTILITIES NOT SHOWN IN PROFILE FOR CLARITY.

**REDUCED**  
 APPROXIMATELY HALF-SCALE

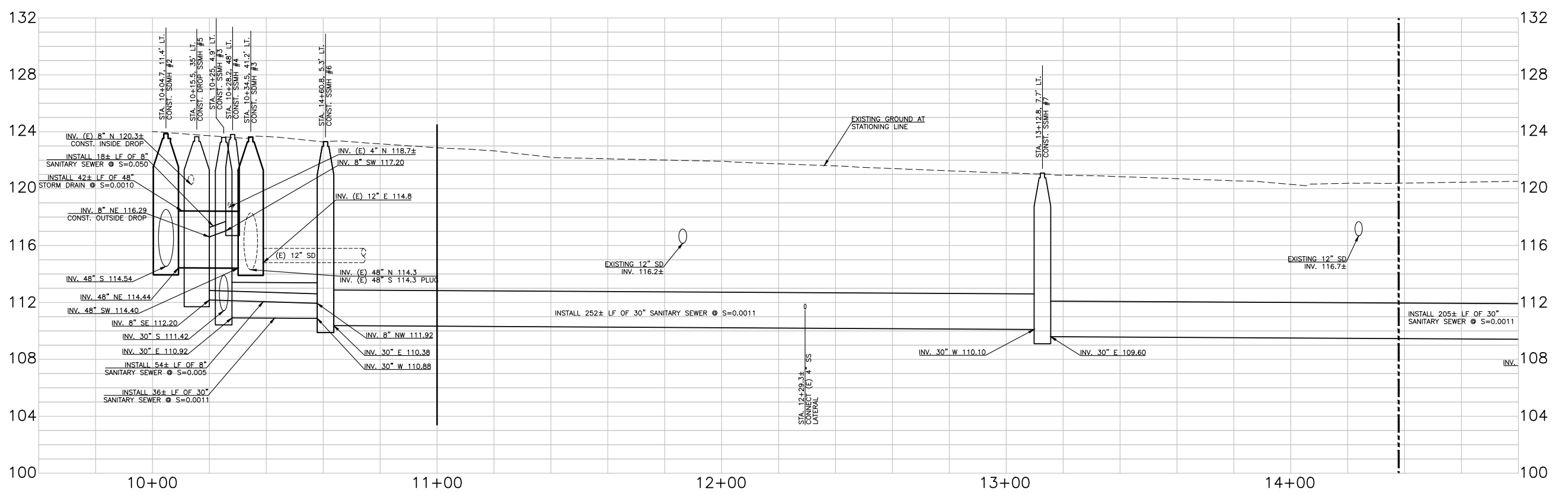

NO.	DATE	REVISIONS



**CITY OF THE DALLES**  
 PUBLIC WORKS DEPARTMENT  
 1215 West First Street  
 The Dalles, Oregon 97058  
 (541) 296-5401



A PLAN AND PROFILE DRAWING FOR:  
**WESTSIDE INTERCEPTOR  
 UPGRADES - PHASE 2**  
 THE DALLES, OREGON

NAME	MHB
DATE	9/2/2025
SCALE	1"=20'
CHECKED	
SHEET	<b>C5.2</b>
OF	31 SHEETS
JOB NO.	2025-010

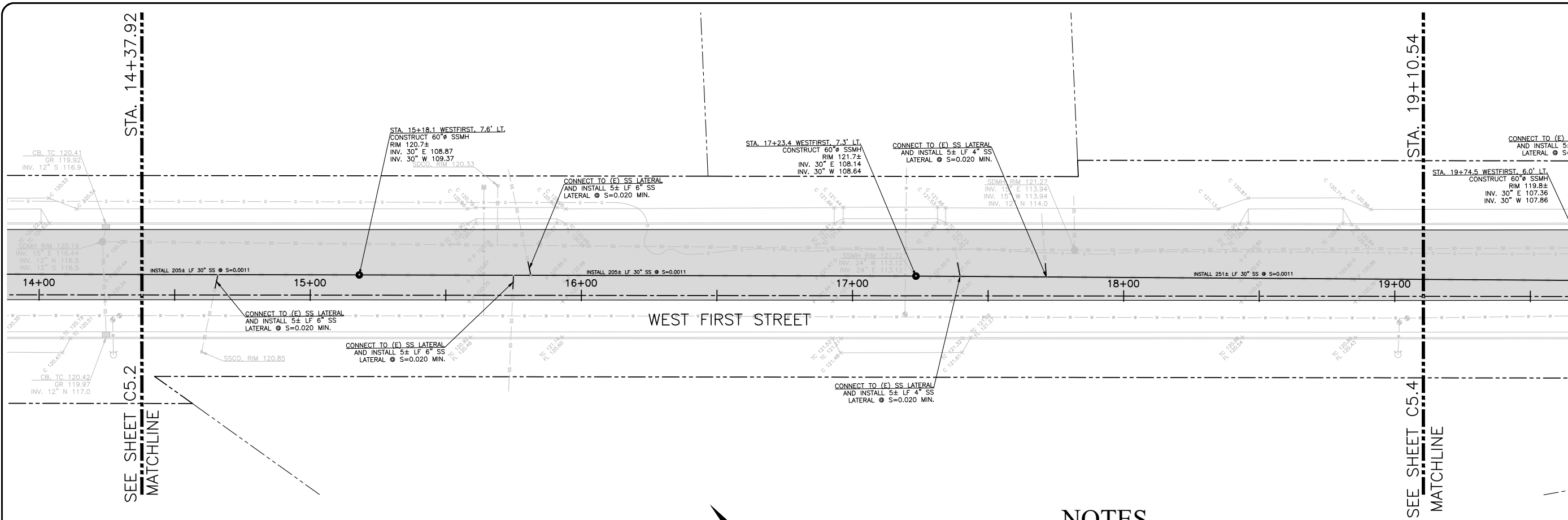

SEE SHEET C5.2  
MATCHLINE

SEE SHEET C5.4  
MATCHLINE

SCALE  
HORIZ. 1"=20'  
VERT. 1"=4'

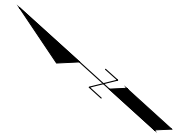

**NOTES**

1. SEE SHEET C0.1 FOR GENERAL NOTES AND INFORMATION.
2. SEE SHEET C3.3 FOR LAYOUT PLAN.
3. EXISTING UTILITIES NOT SHOWN IN PROFILE FOR CLARITY.

**REDUCED**  
APPROXIMATELY HALF-SCALE

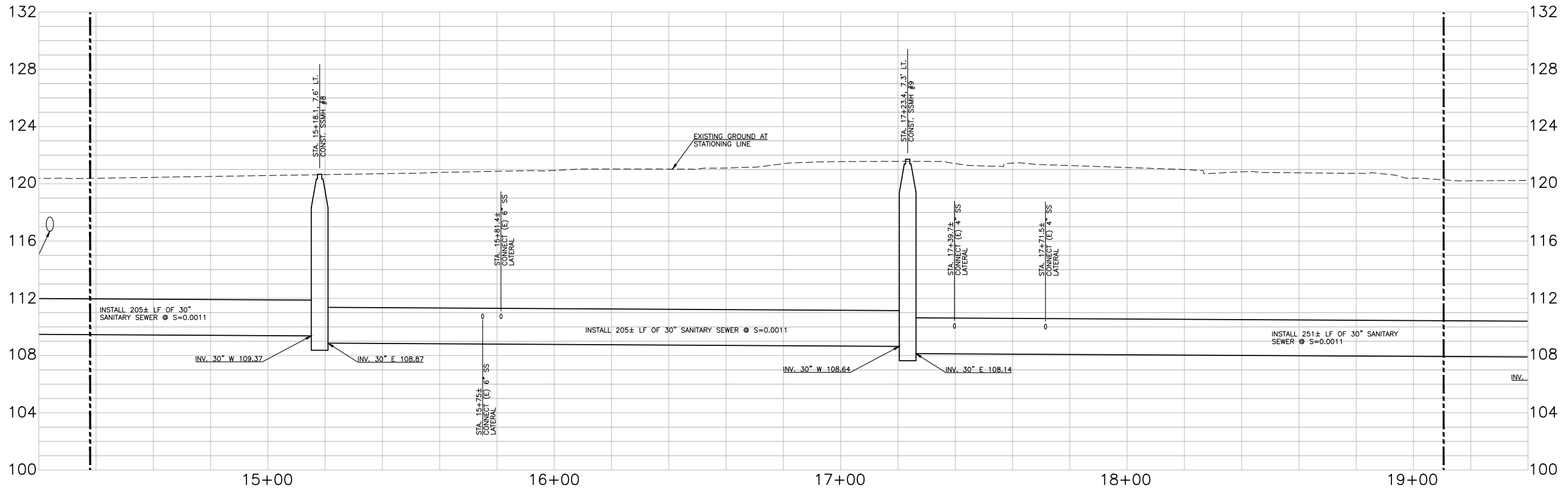

NO.	DATE	REVISIONS



**CITY OF THE DALLES**  
PUBLIC WORKS DEPARTMENT  
1215 West First Street  
The Dalles, Oregon 97058  
(541) 296-5401



A PLAN AND PROFILE DRAWING FOR:  
**WESTSIDE INTERCEPTOR  
UPGRADES - PHASE 2**  
THE DALLES, OREGON

NAME	MHB
DATE	9/2/2025
SCALE	1"=20'
CHECKED	
SHEET	<b>C5.3</b>
OF	31 SHEETS
JOB NO.	2025-010

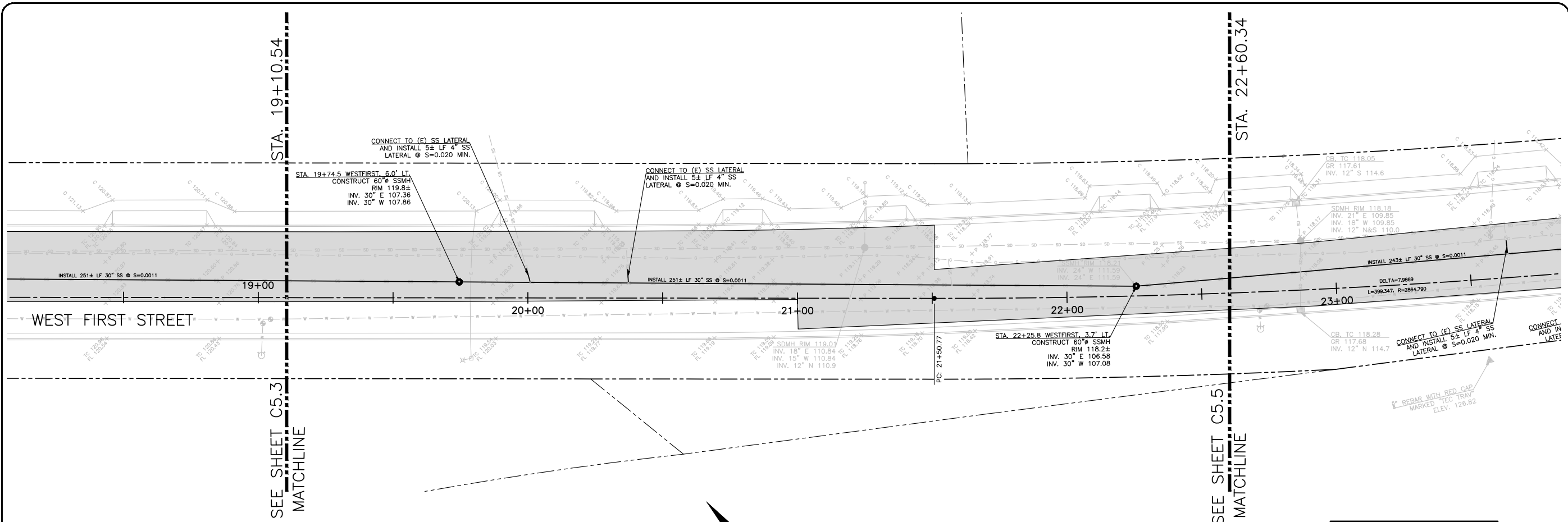

SEE SHEET C5.3  
MATCHLINE

SEE SHEET C5.5  
MATCHLINE

SCALE  
HORIZ. 1"=20'  
VERT. 1"=4'

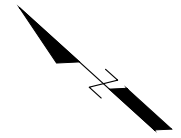

**NOTES**

1. SEE SHEET C0.1 FOR GENERAL NOTES AND INFORMATION.
2. SEE SHEET C3.4 FOR LAYOUT PLAN.
3. EXISTING UTILITIES NOT SHOWN IN PROFILE FOR CLARITY.

**REDUCED**  
APPROXIMATELY HALF-SCALE

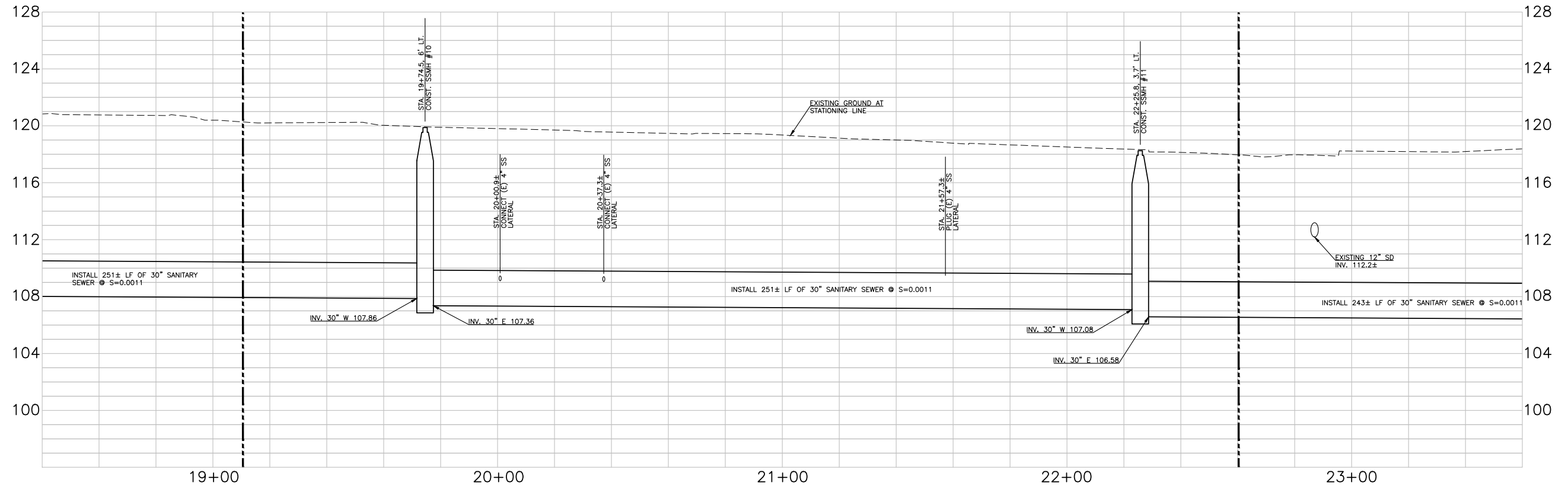

NO.	DATE	REVISIONS



**CITY OF THE DALLES**  
PUBLIC WORKS DEPARTMENT  
1215 West First Street  
The Dalles, Oregon 97058  
(541) 296-5401



A PLAN AND PROFILE DRAWING FOR:  
**WESTSIDE INTERCEPTOR  
UPGRADES - PHASE 2**  
THE DALLES, OREGON

NAME	MHB
DATE	9/2/2025
SCALE	1"=20'
CHECKED	
SHEET	<b>C5.4</b>
OF	31 SHEETS
JOB NO.	2025-010

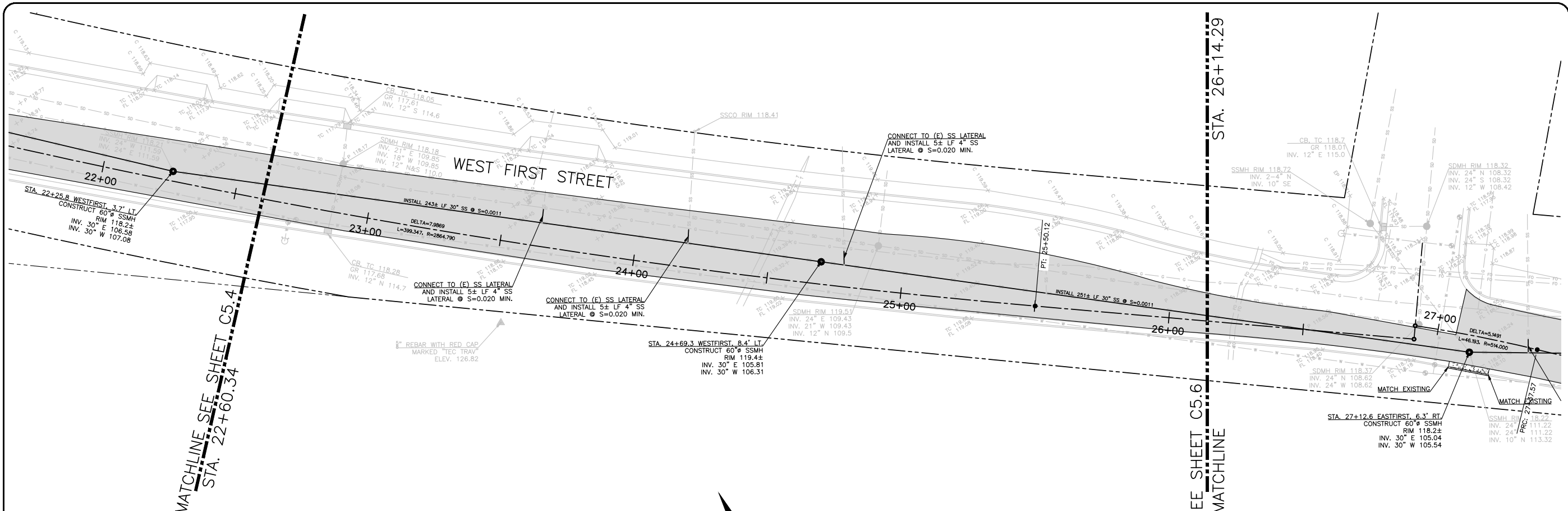

MATCHLINE SEE SHEET C5.4  
STA. 22+60.34

SEE SHEET C5.6  
MATCHLINE  
STA. 26+14.29

SCALE  
HORIZ. 1"=20'  
VERT. 1"=4'

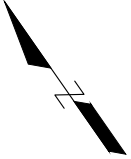

**NOTES**

- SEE SHEET C0.1 FOR GENERAL NOTES AND INFORMATION.
- SEE SHEET C3.5 FOR LAYOUT PLAN.
- EXISTING UTILITIES NOT SHOWN IN PROFILE FOR CLARITY.

**REDUCED**  
APPROXIMATELY HALF-SCALE

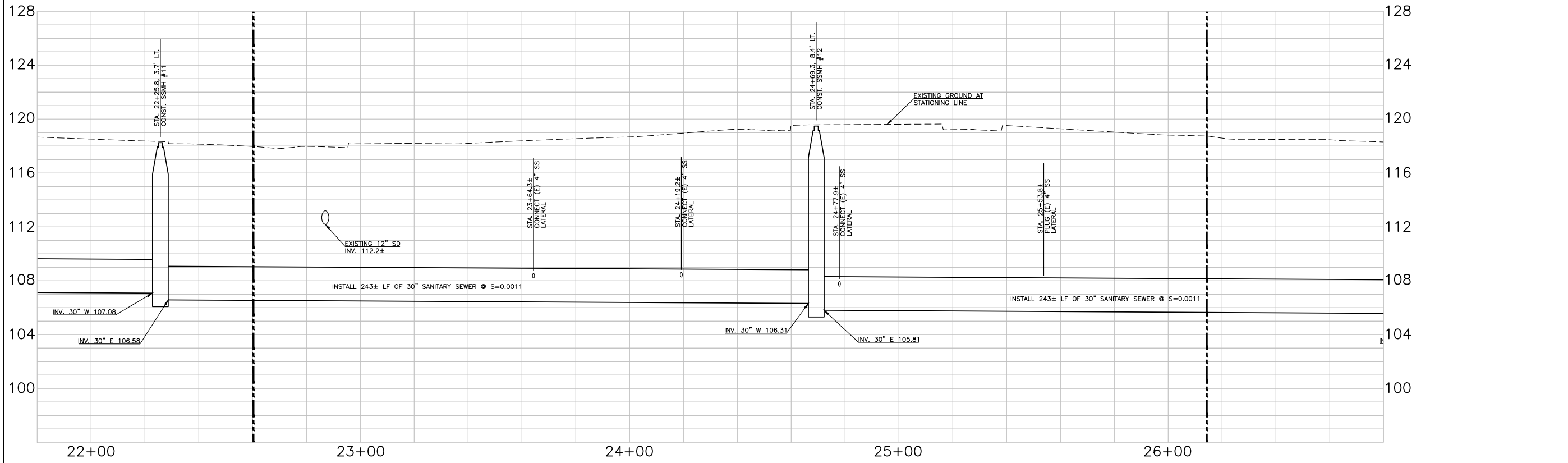

NO.	DATE	REVISIONS



**CITY OF THE DALLES**  
PUBLIC WORKS DEPARTMENT  
1215 West First Street  
The Dalles, Oregon 97058  
(541) 296-5401



A PLAN AND PROFILE DRAWING FOR:  
**WESTSIDE INTERCEPTOR  
UPGRADES - PHASE 2**  
THE DALLES, OREGON

NAME	MHB
DATE	9/2/2025
SCALE	1"=20'
CHECKED	
SHEET	<b>C5.5</b>
OF	31 SHEETS
JOB NO.	2025-010

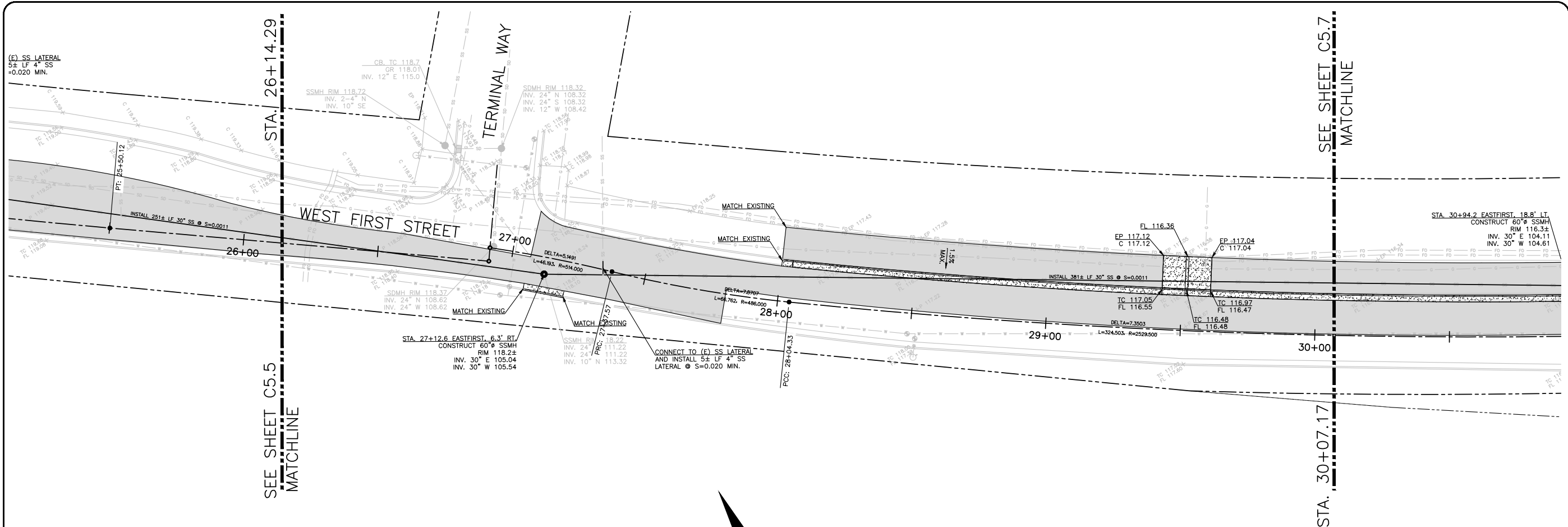

SEE SHEET C5.5 MATCHLINE

SEE SHEET C5.7 MATCHLINE

SCALE  
 HORIZ. 1"=20'  
 VERT. 1"=4'

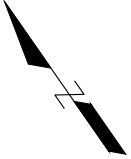

**NOTES**

- SEE SHEET C0.1 FOR GENERAL NOTES AND INFORMATION.
- SEE SHEET C3.6 FOR LAYOUT PLAN.
- EXISTING UTILITIES NOT SHOWN IN PROFILE FOR CLARITY.

**REDUCED**  
 APPROXIMATELY HALF-SCALE

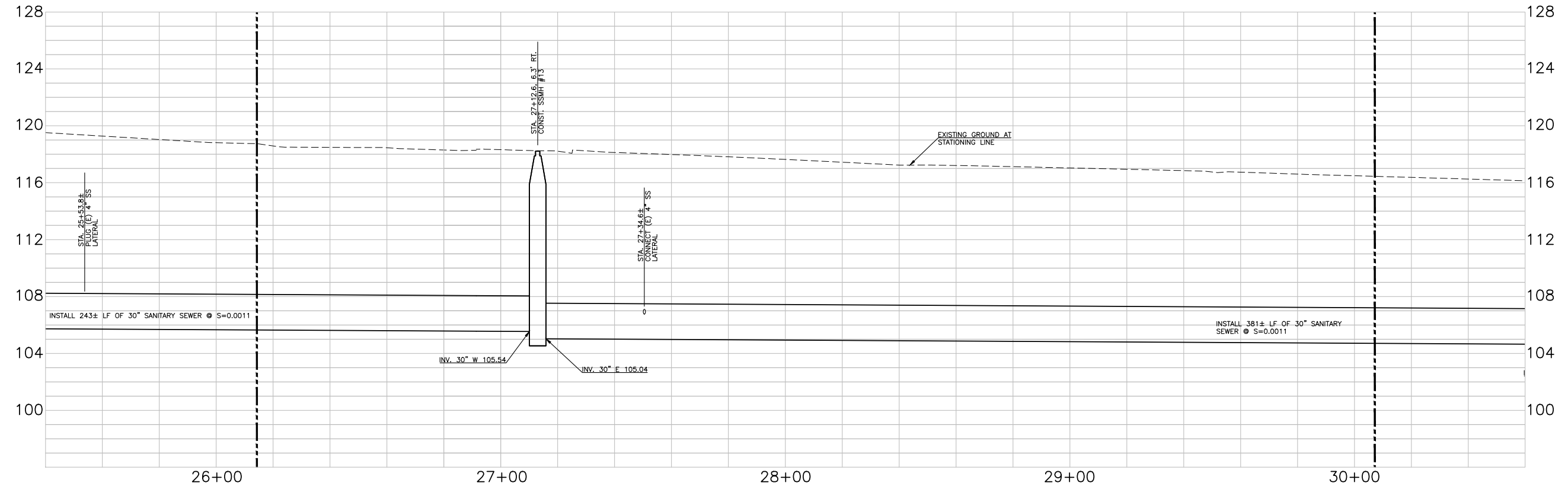

NO.	DATE	REVISIONS



**CITY OF THE DALLES**  
 PUBLIC WORKS DEPARTMENT  
 1215 West First Street  
 The Dalles, Oregon 97058  
 (541) 296-5401

A PLAN AND PROFILE DRAWING FOR:  
**WESTSIDE INTERCEPTOR  
 UPGRADES - PHASE 2**  
 THE DALLES, OREGON

NAME	MHB
DATE	9/2/2025
SCALE	1"=20'
CHECKED	
SHEET	<b>C5.6</b>
OF	31 SHEETS
JOB NO.	2025-010

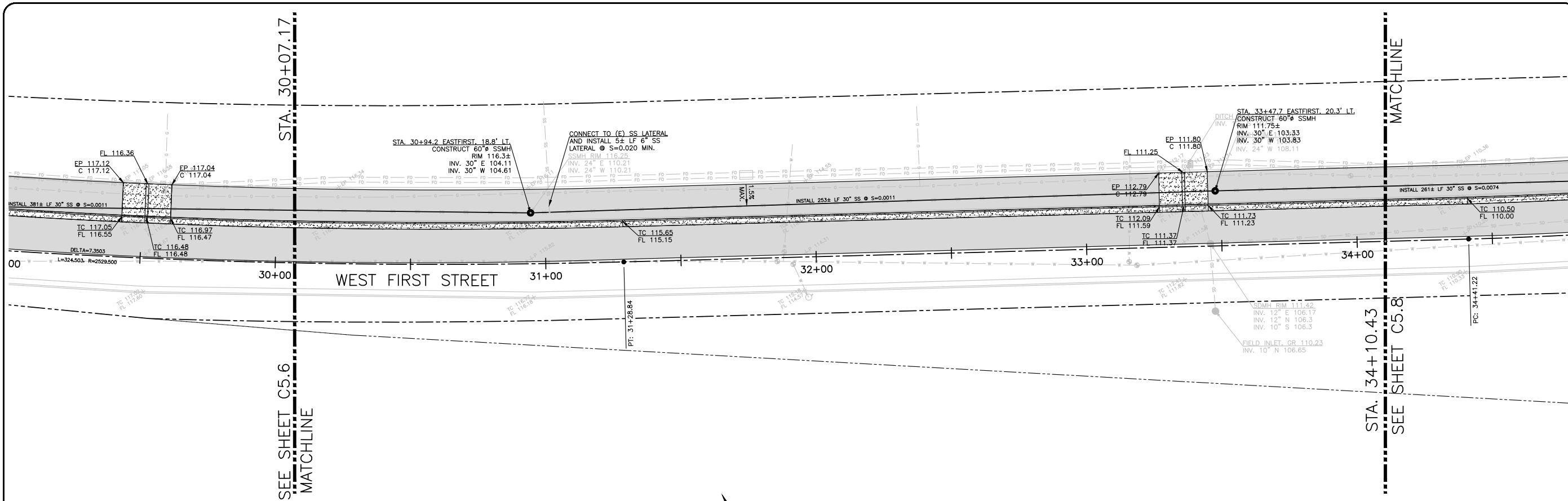

SCALE  
 HORIZ. 1"=20'  
 VERT. 1"=4'

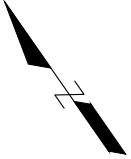

**NOTES**

- SEE SHEET C0.1 FOR GENERAL NOTES AND INFORMATION.
- SEE SHEET C3.7 FOR LAYOUT PLAN.
- EXISTING UTILITIES NOT SHOWN IN PROFILE FOR CLARITY.

**REDUCED**  
 APPROXIMATELY HALF-SCALE

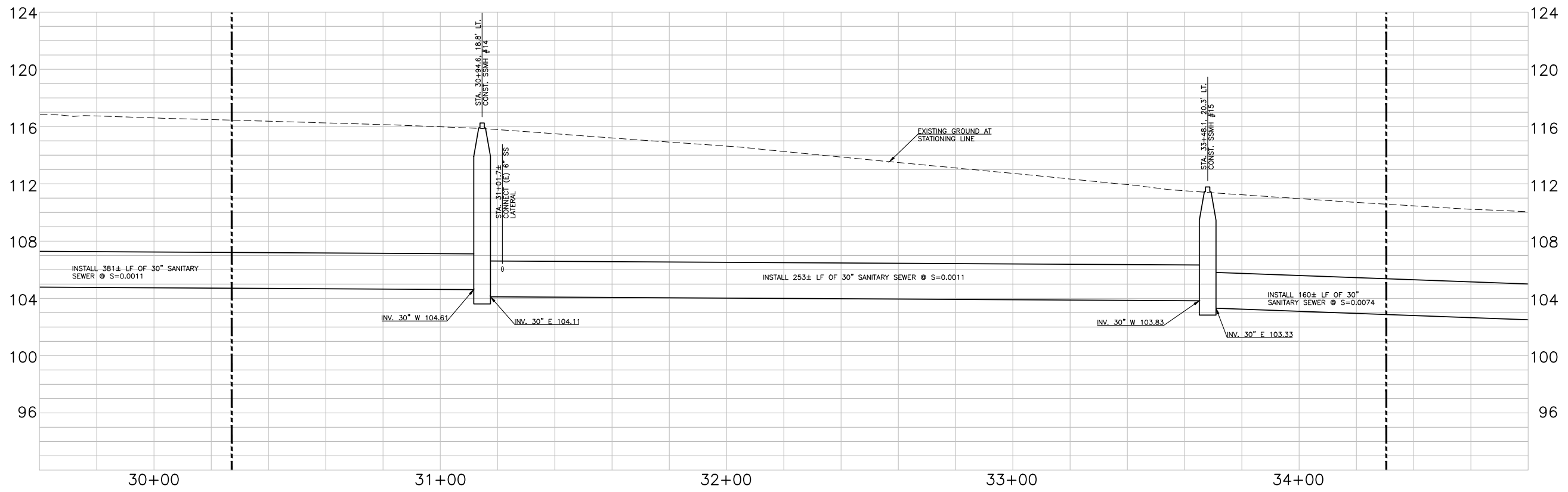

NO.	DATE	REVISIONS



**CITY OF THE DALLES**  
 PUBLIC WORKS DEPARTMENT  
 1215 West First Street  
 The Dalles, Oregon 97058  
 (541) 296-5401



A PLAN AND PROFILE DRAWING FOR:  
**WESTSIDE INTERCEPTOR  
 UPGRADES - PHASE 2**  
 THE DALLES, OREGON

NAME	MHB
DATE	9/2/2025
SCALE	1"=20'
CHECKED	
SHEET	<b>C5.7</b>
OF	31 SHEETS
JOB NO.	2025-010

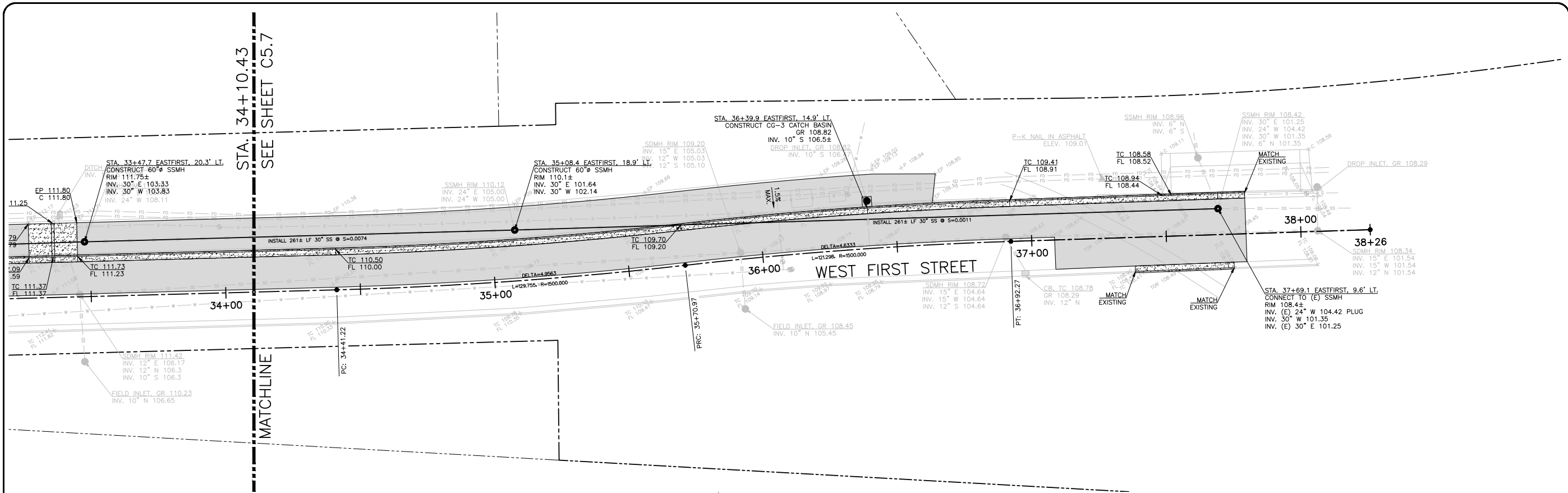

SCALE  
 HORIZ. 1"=20'  
 VERT. 1"=4'

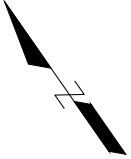

**NOTES**

- SEE SHEET C0.1 FOR GENERAL NOTES AND INFORMATION.
- SEE SHEET C3.8 FOR LAYOUT PLAN.
- EXISTING UTILITIES NOT SHOWN IN PROFILE FOR CLARITY.

**REDUCED**  
 APPROXIMATELY HALF-SCALE

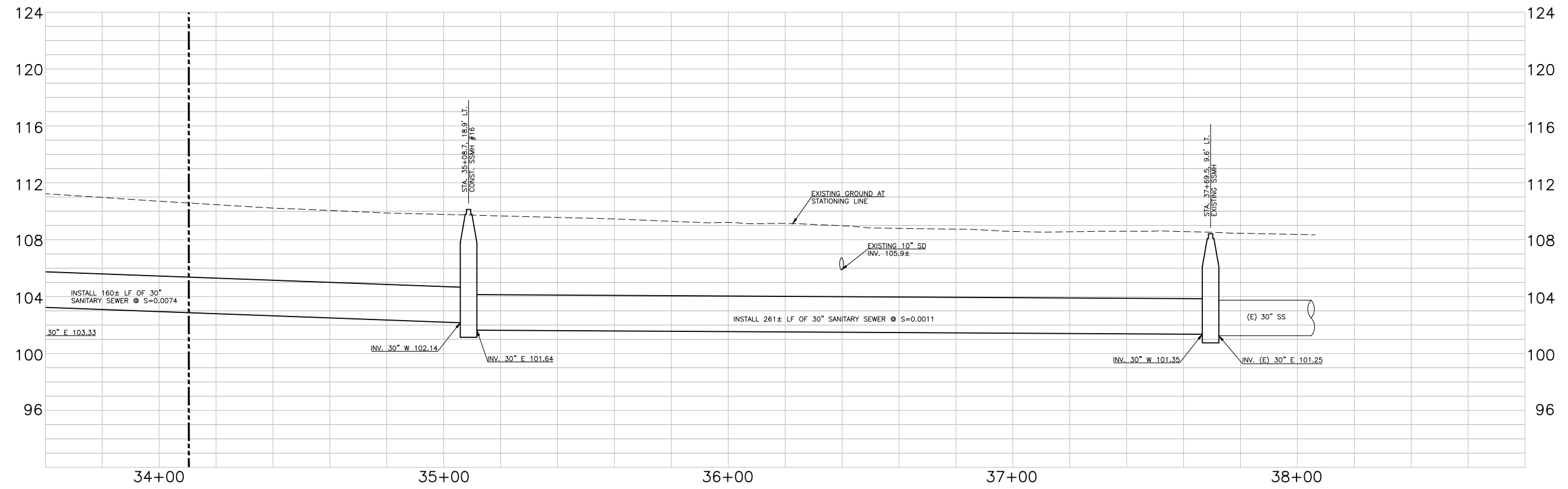

NO.	DATE	REVISIONS



**CITY OF THE DALLES**  
 PUBLIC WORKS DEPARTMENT  
 1215 West First Street  
 The Dalles, Oregon 97058  
 (541) 296-5401



A PLAN AND PROFILE DRAWING FOR:  
**WESTSIDE INTERCEPTOR  
 UPGRADES - PHASE 2**  
 THE DALLES, OREGON

NAME	MHB
DATE	9/2/2025
SCALE	1"=20'
CHECKED	
SHEET	<b>C5.8</b>
OF	31 SHEETS
JOB NO.	2025-010

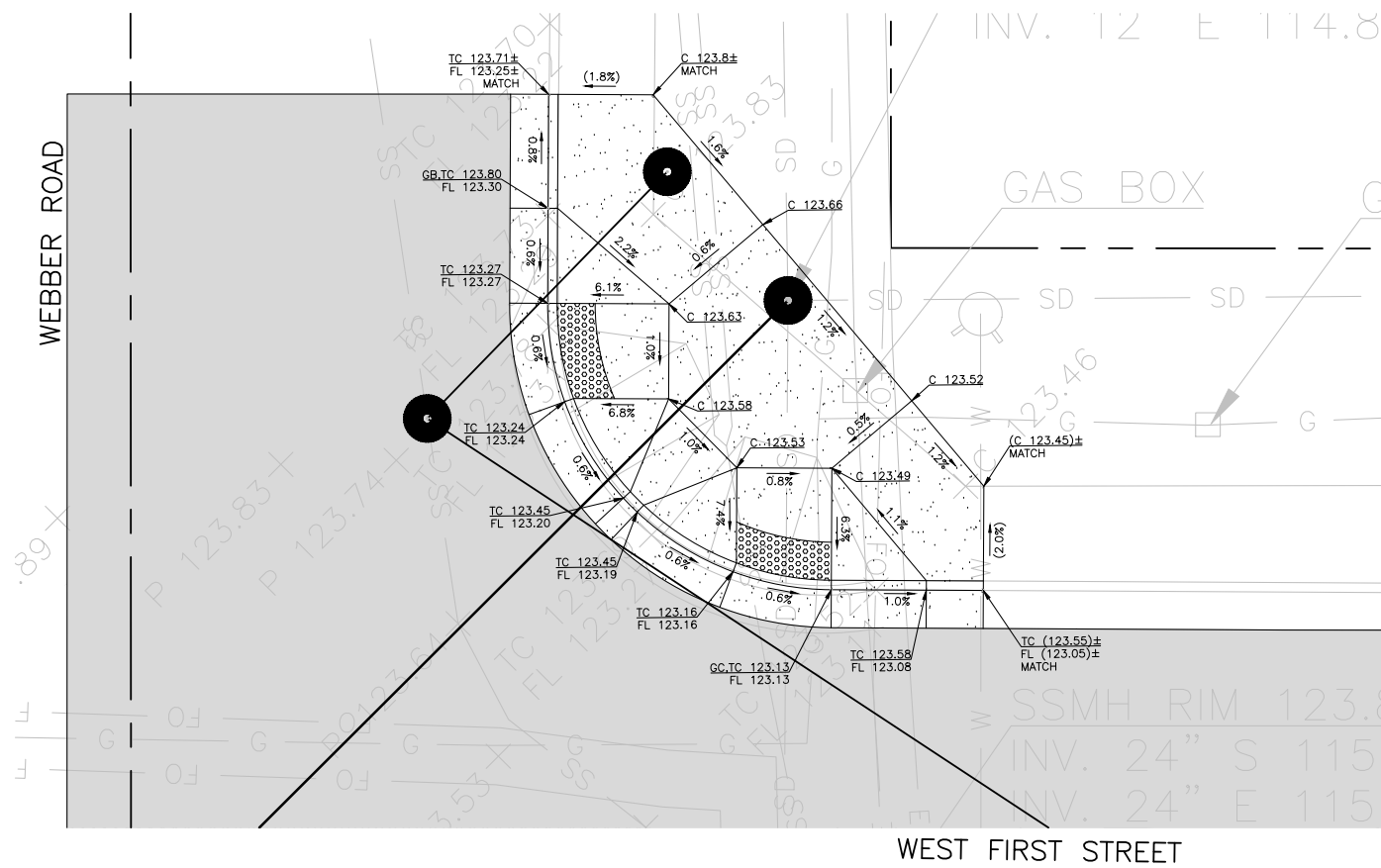

**REDUCED**  
 APPROXIMATELY HALF-SCALE

NO.	DATE	REVISIONS



**CITY OF THE DALLES**  
 PUBLIC WORKS DEPARTMENT  
 1215 West First Street  
 The Dalles, Oregon 97058  
 (541) 296-5401

A ADA RAMP DETAIL SHEET FOR:  
**WESTSIDE INTERCEPTOR  
 UPGRADES - PHASE 2**  
 THE DALLES, OREGON

NAME	MHB
DATE	9/2/2025
SCALE	1"=5'
CHECKED	
SHEET	<b>C7.1</b>
OF	31 SHEETS
JOB NO.	2025-010

rd300.dgn 20-JUL-2020

00ECON

**TABLE A**

"A" (in)	"B" (in)	"C" (in)	"D" (in)
4	10	4	8
6	10	4	8
8	10	6	10
10	10	6	10
12	12	6	10
15	12	6	10
18	16	6	12
21	16	6	12
24	18	6	12
30	18	6	12
36	24	6	14
42	24	6	14
48	24	6	14
54	24	6	14
60	24	6	14
66	24	6	14
72	24	6	14

For pipes over 72" diameter, see general note 3.

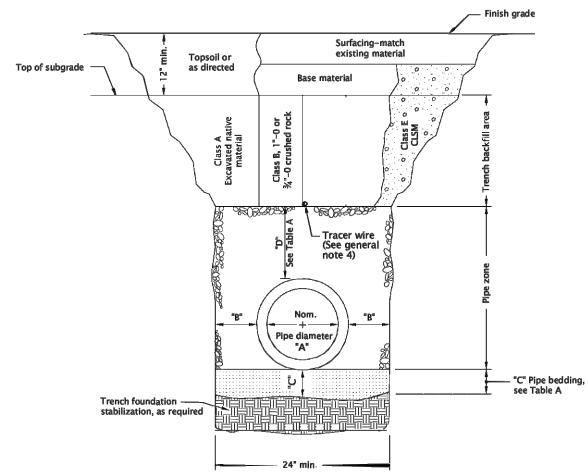

**MULTIPLE INSTALLATIONS**

DIAMETER	MIN. SPACE BETWEEN PIPES
Up to 48"	24"
48" to 72"	One half (1/2) dia. of pipe

**GENERAL NOTES FOR ALL DETAILS ON THIS SHEET:**

- Surfacing of paved areas shall comply with street cut Std. Dwg. RD302.
- For pipe installation in embankment areas where the trench method will not be used and the pipe is  $\pm 36'$  diameter, increase dimension "B" to nominal pipe diameter.
- Pipes over 72" diameter are structures, and are not applicable to this drawing.
- See Std. Dwg. RD336 for tracer wire details (When required).

CALC. BOOK NO. N/A SIDR DATE 14-JUL-2014

NOTE: All material and workmanship shall be in accordance with the current City of The Dalles Standard Specifications.

**CITY OF THE DALLES STANDARD DRAWINGS**

**TRENCH BACKFILL, BEDDING, PIPE ZONE AND MULTIPLE INSTALLATIONS**

DATE 2025 REVISION DESCRIPTION

Effective Date: January 1, 2025 – December 31, 2025 RD300

rd302.dgn 20-JUL-2020

00ECON

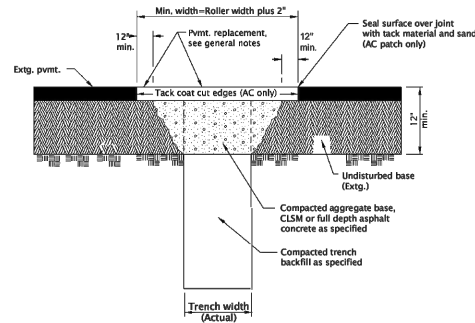

**GENERAL NOTES FOR ALL DETAILS ON THIS SHEET:**

- All existing AC or PCC pavement shall be sawcut prior to repaving.
- Concrete pavement shall be replaced with concrete to a minimum thickness of 8" or to the thickness of removed pavement, whichever is greater.
- For joining new concrete to existing concrete, see contract plans for specific details.
- Place AC mix minimum thkn. of 6" or the thkn. of the removed pavement, whichever is greater. Compact as specified.

CALC. BOOK NO. N/A SIDR DATE 20-JUL-2020

NOTE: All material and workmanship shall be in accordance with the current City of The Dalles Standard Specifications.

**CITY OF THE DALLES STANDARD DRAWINGS**

**STREET CUT**

DATE 2025 REVISION DESCRIPTION

Effective Date: May 1, 2025 – December 31, 2025 RD302

rd336.dgn 20-JUL-2020

00ECON

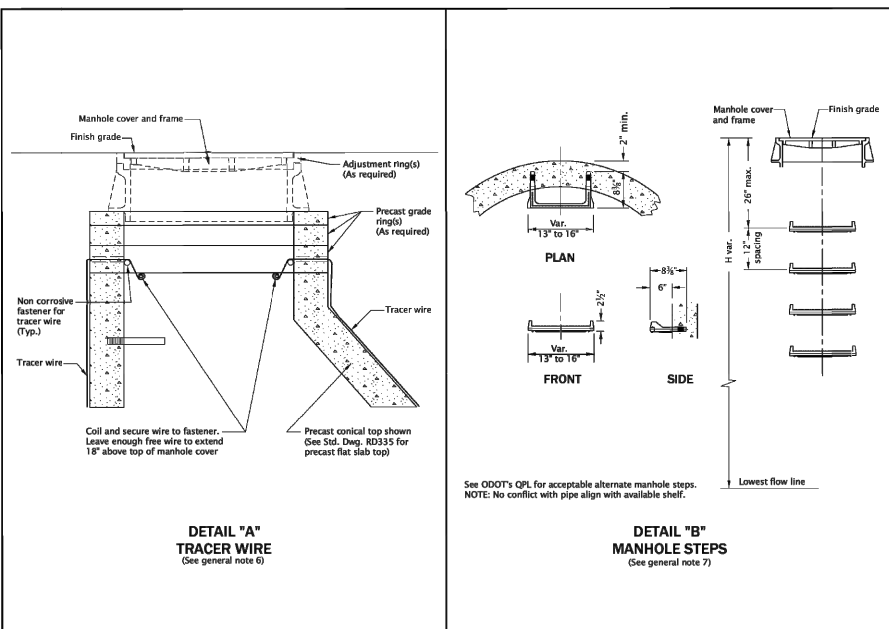

**GENERAL NOTES FOR ALL DETAILS ON THIS SHEET:**

- All precast products shall conform to requirements of ASTM C478.
- Standard precast manhole section diameter shall be 48". Use 42" if specified by the Engineer.
- See Std. Dwg. RD345 for pipe to manhole connections.
- See Std. Dwg. RD344 for manhole base section.
- Adjust 24" maximum.
- All connecting pipes shall have a tracer wire, or approved alternate. Place tracer wire directly over pipe centerline and on top of the pipe zone material.

**DETAIL "A" TRACER WIRE**  
(See general note 6)

**DETAIL "B" MANHOLE STEPS**  
(See general note 7)

See ODOT's QPL for acceptable alternate manhole steps. NOTE: No conflict with pipe align with available shelf.

CALC. BOOK NO. N/A SIDR DATE 16-JAN-2019

NOTE: All material and workmanship shall be in accordance with the current City of The Dalles Standard Specifications.

**CITY OF THE DALLES STANDARD DRAWINGS**

**STANDARD MANHOLE DETAILS**

DATE 2025 REVISION DESCRIPTION

Effective Date: January 1, 2025 – December 31, 2025 RD336

rd338.dgn 20-JUL-2020

00ECON

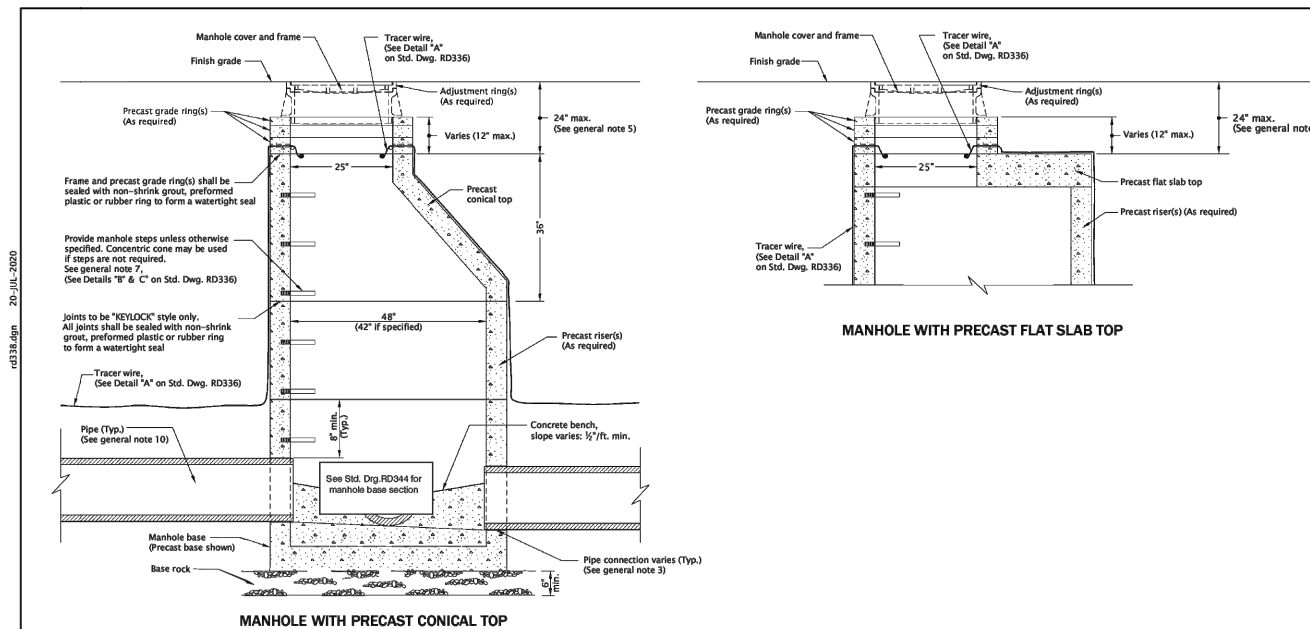

**GENERAL NOTES FOR ALL DETAILS ON THIS SHEET:**

- All precast products shall conform to requirements of ASTM C478.
- Standard precast manhole section diameter shall be 48". Use 42" if specified by the Engineer.
- See Std. Dwg. RD345 for pipe to manhole connections.
- See Std. Dwg. RD344 for manhole base section.
- Adjust 24" maximum.
- All connecting pipes shall have a tracer wire, or approved alternate.
- See Std. Dwg. RD336 for manhole steps.
- See Std. Dwg. RD336 for details not shown.
- See Std. Dwg. RD356 for manhole covers and frames, manhole adjustment rings, etc.
- Max. pipe diameter varies with pipe material.
- See Std. Dwg. RD342 for shallow manholes.
- Location, elevation, diameter, slope, and number of pipe(s) varies, see project plans.
- This detail limited to interior drop of 24". See Std. Dwg. RD350 or RD352 for drop manhole details for drops in excess of 24".

CALC. BOOK NO. N/A SIDR DATE 21-JUN-2019

NOTE: All material and workmanship shall be in accordance with the current City of The Dalles Standard Specifications.

**CITY OF THE DALLES STANDARD DRAWINGS**

**STANDARD SANITARY SEWER MANHOLE**

DATE 2025 REVISION DESCRIPTION

Effective Date: January 1, 2025 – December 31, 2025 RD338

REVISIONS

NO.	DATE	DESCRIPTION

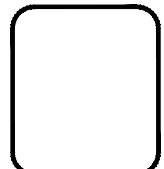

**CITY OF THE DALLES**  
PUBLIC WORKS DEPARTMENT  
1215 West First Street  
The Dalles, Oregon 97058  
(541) 296-5401



A DETAIL SHEET FOR:  
**WESTSIDE INTERCEPTOR UPGRADES – PHASE 2**  
THE DALLES, OREGON

NAME	MHB
DATE	9/2/2025
SCALE	AS NOTED
CHECKED	
SHEET	
C7.2	
OP	31 SHEETS
JOB NO.	2025-010

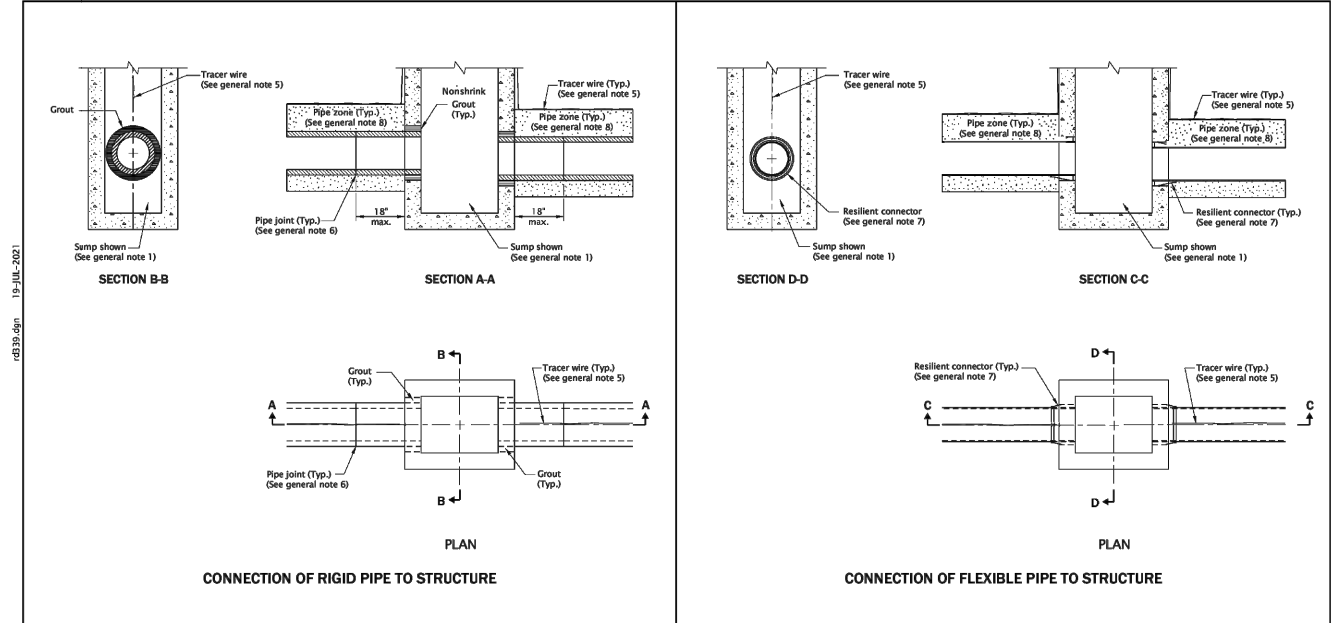

**GENERAL NOTES FOR ALL DETAILS ON THIS SHEET:**

- See Std. Dwg. RD364, RD365, and RD366 for inlet details not shown.
- See appropriate standard drawings or special project details for other similar structures.
- Location, elevation, diameter, slope, and number of pipe(s) varies, see project plans.
- Maximum pipe diameter varies with pipe material.
- All connecting pipes shall have a tracer wire, or approved alternate. See Std. Dwg. RD336 for tracer wire details.
- When flexible pipe is used, install resilient connectors conforming to requirements of ASTM C923.
- Pipe zone varies, see Std. Dwg. RD300.

**Effective Date: January 1, 2025 – December 31, 2025** RD339

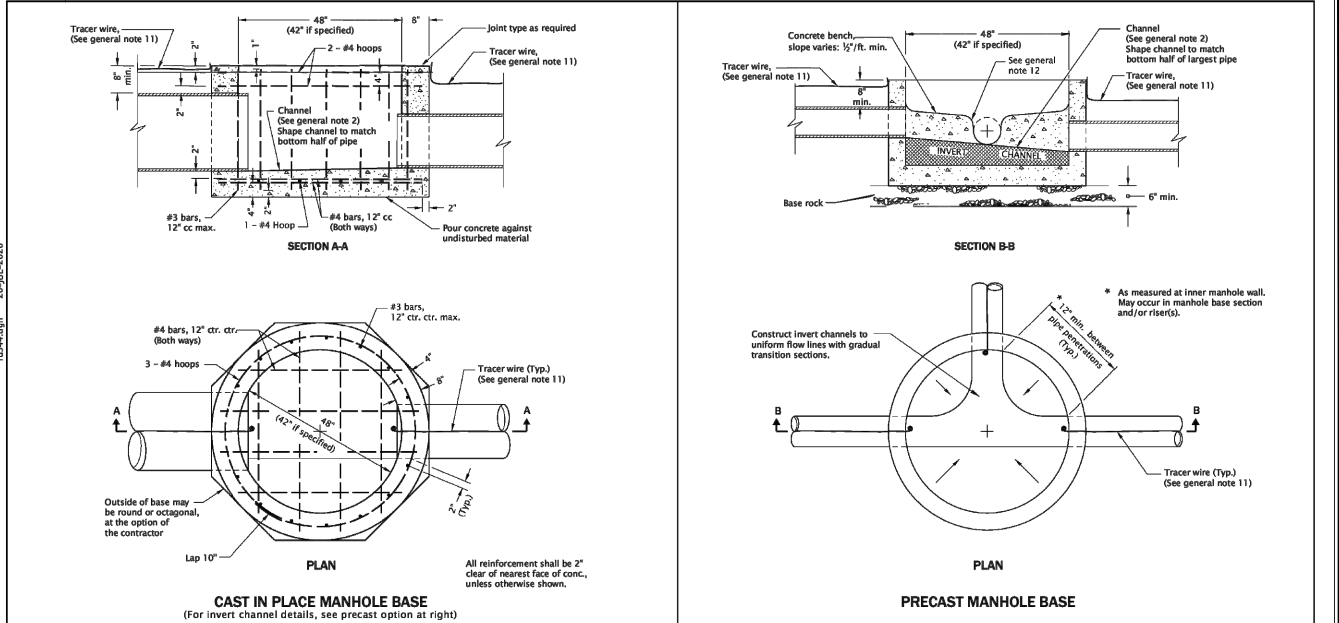

**GENERAL NOTES FOR ALL DETAILS ON THIS SHEET:**

- All concrete shall be commercial grade concrete.
- Channels shall be constructed to provide smooth slopes and radii to outlet pipe.
- Bases may be precast or cast in place.
- Max. pipe diameter varies with pipe material.
- Use on 42\"/>

**Effective Date: January 1, 2025 – December 31, 2025** RD344

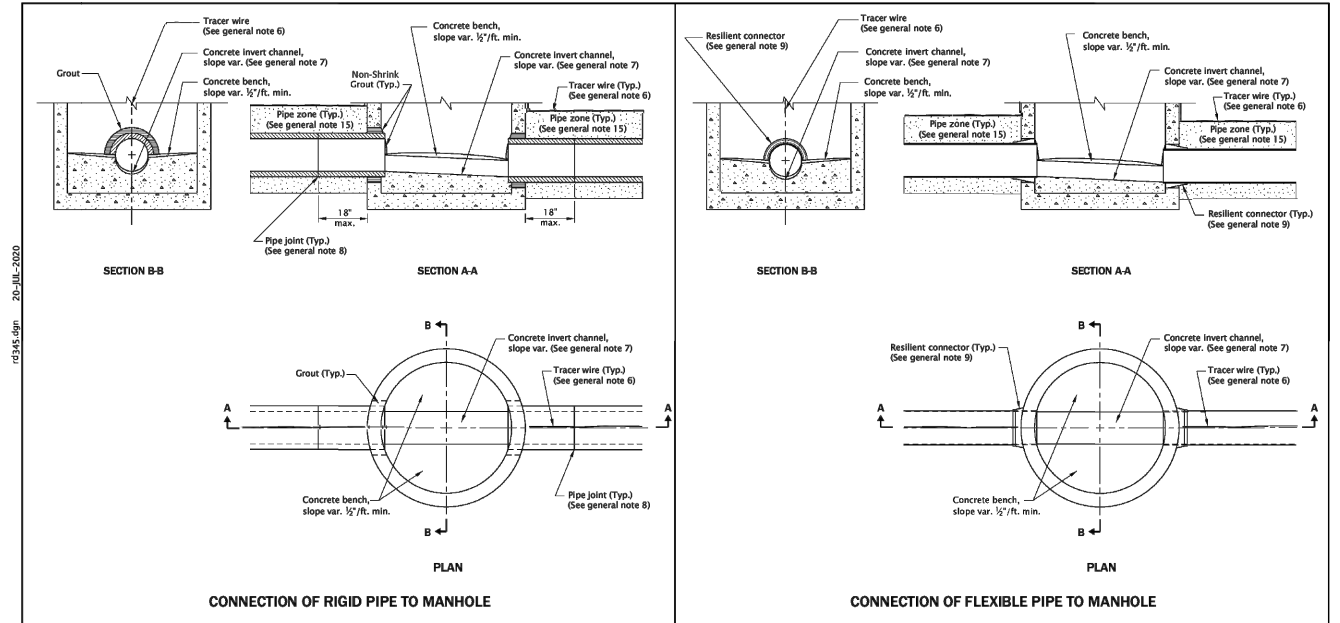

**GENERAL NOTES FOR ALL DETAILS ON THIS SHEET:**

- All precast sections shall conform to requirements of ASTM C478.
- Manhole base sections may be precast or cast-in-place.
- All concrete shall be commercial grade concrete.
- Location, elevation, diameter, slope, and number of pipe(s) varies, see project plans.
- Max. pipe diameter varies with pipe material.
- All connecting pipes shall have a tracer wire, or approved alternate. See Std. Dwg. RD336 for tracer wire details.
- Invert channels shall be constructed to provide smooth slopes and radii to outlet pipe.
- When flexible pipe is used, install resilient connectors conforming to requirements of ASTM C923.
- See Std. Dwg. RD335, RD336, and RD338 for details not shown.
- See Std. Dwg. RD336 for manhole steps details.
- See Std. Dwg. RD342 for shallow manholes.
- See Std. Dwg. RD344 for manhole base section.
- See Std. Dwg. RD356 for manhole covers and frames, manhole adjustment rings, etc.
- Pipe zone varies, see Std. Dwg. RD300.

**Effective Date: January 1, 2025 – December 31, 2025** RD345

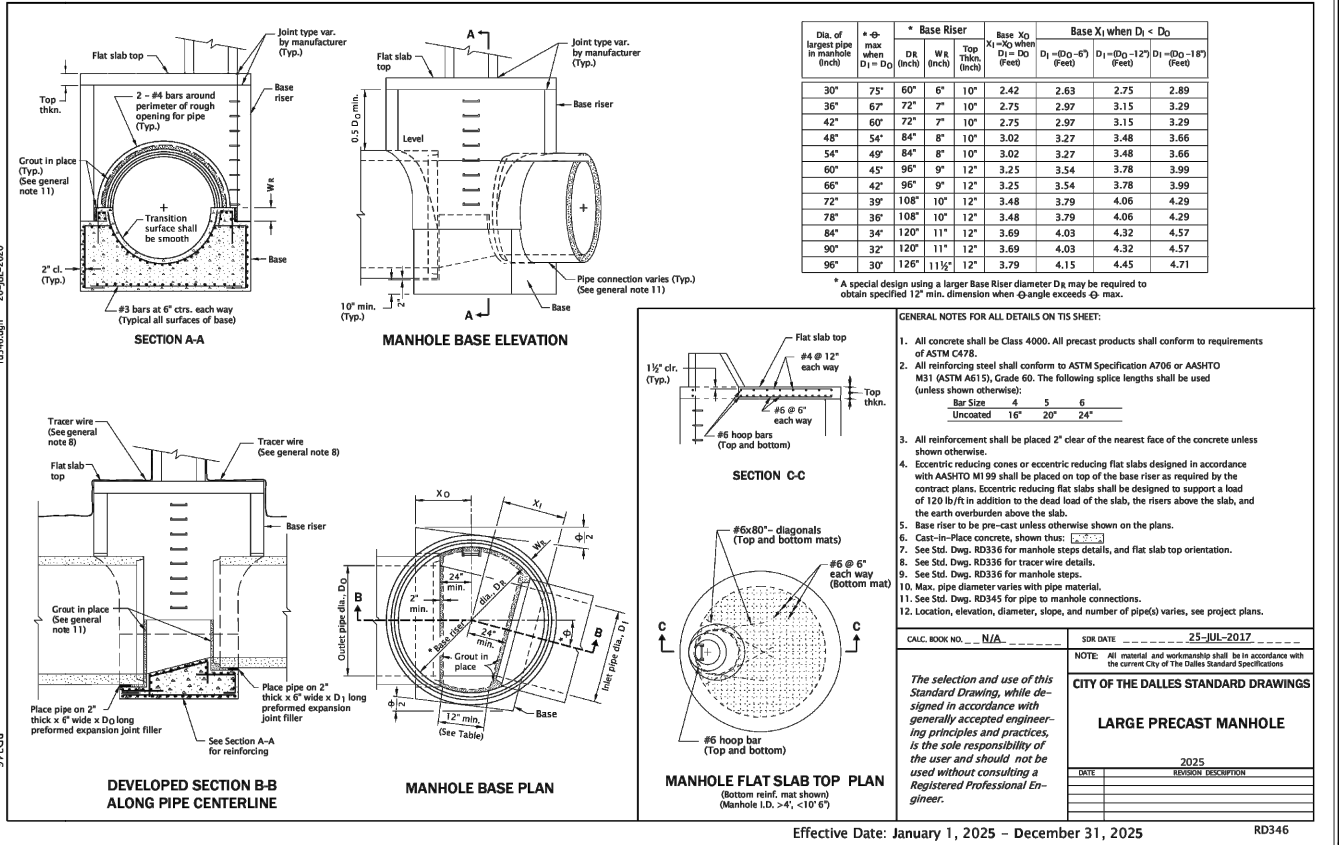

rd339.dgn 20-JUL-2021

rd345.dgn 20-JUL-2020

rd344.dgn 20-JUL-2020

rd346.dgn 20-JUL-2020

NO.	DATE	REVISIONS

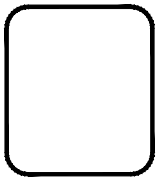

**CITY OF THE DALLES**  
PUBLIC WORKS DEPARTMENT  
1215 West First Street  
The Dalles, Oregon 97058  
(541) 296-5401

A DETAIL SHEET FOR:  
**WESTSIDE INTERCEPTOR  
UPGRADES - PHASE 2**  
THE DALLES, OREGON

NAME	MHB
DATE	9/2/2025
SCALE	AS NOTED
CHECKED	
SHEET	
<b>C73</b>	
OF 31 SHEETS	
JOB NO.	2025-010



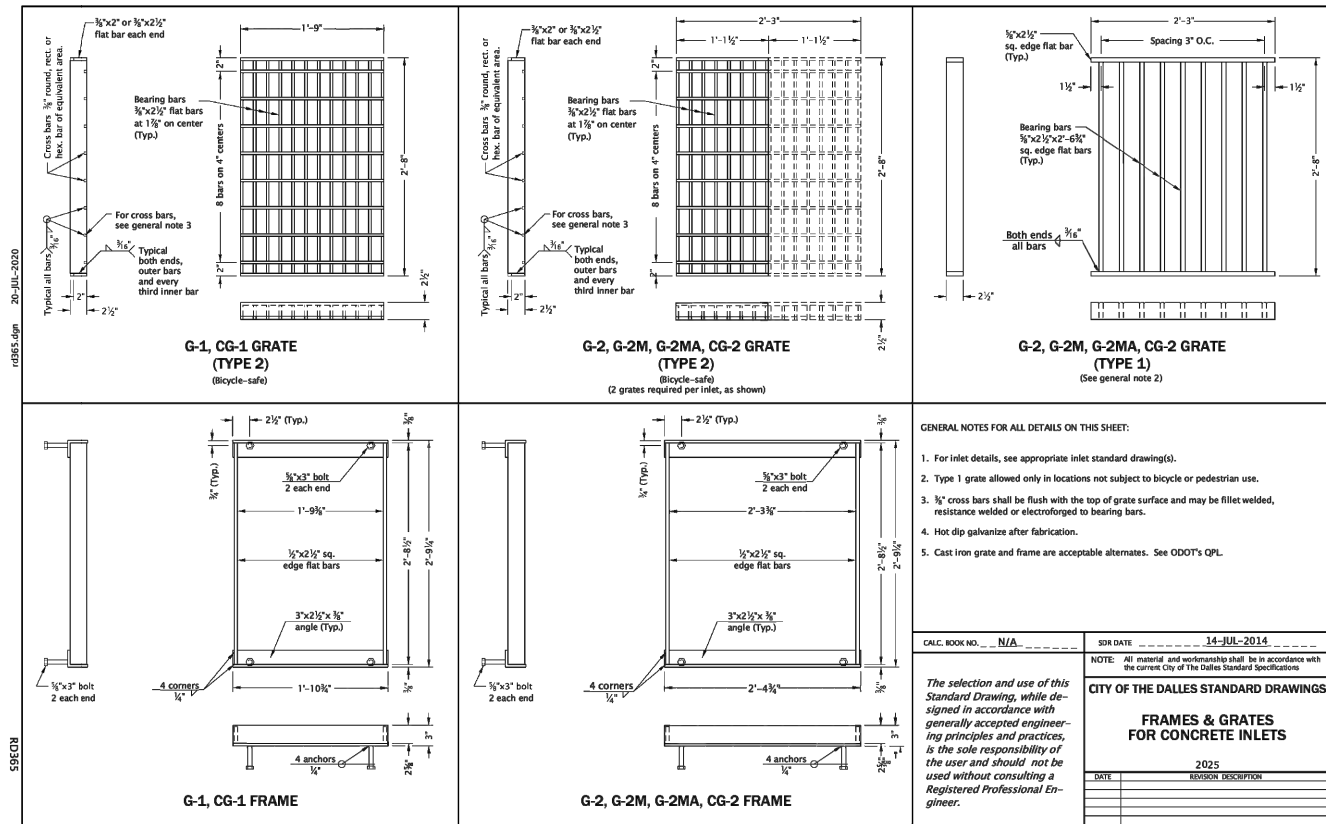

Effective Date: January 1, 2025 - December 31, 2025 RD365

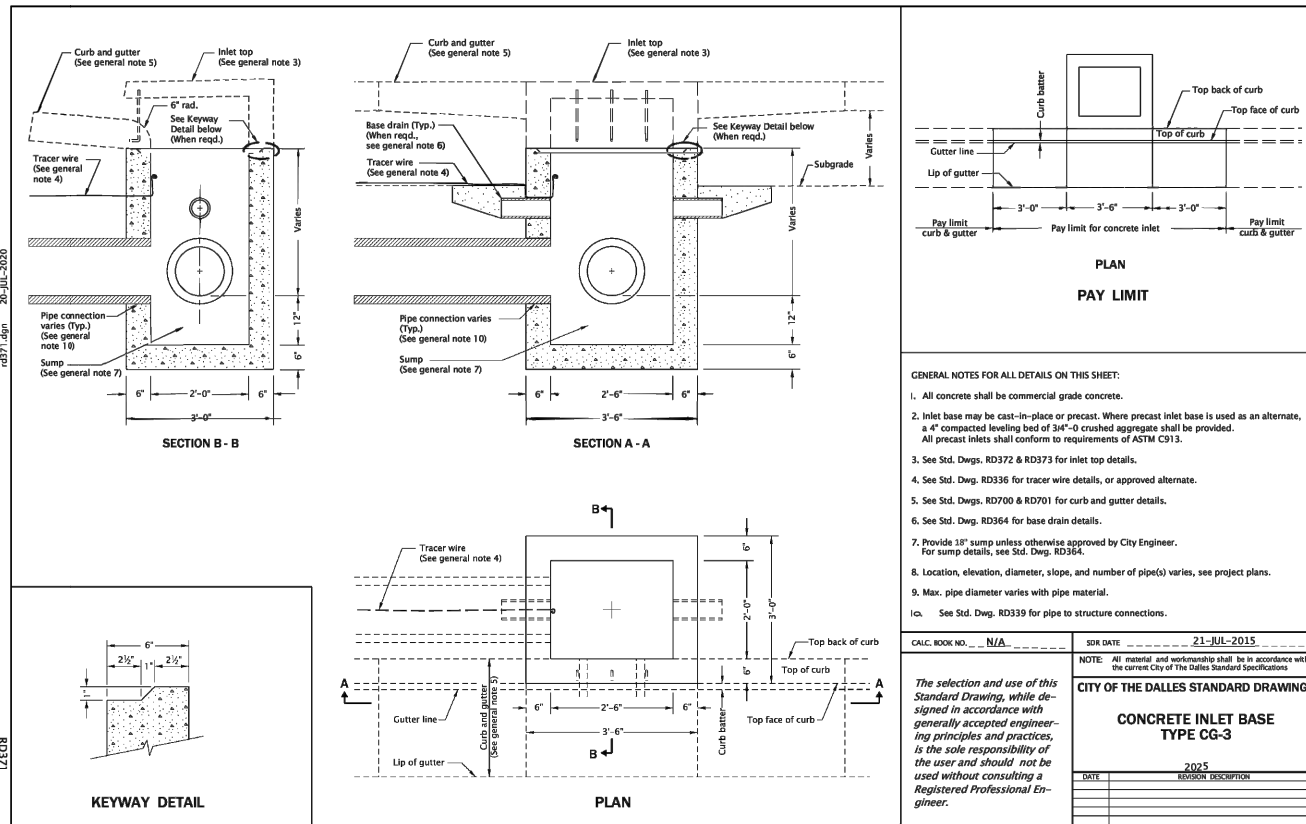

Effective Date: January 1, 2025 - December 31, 2025 RD371

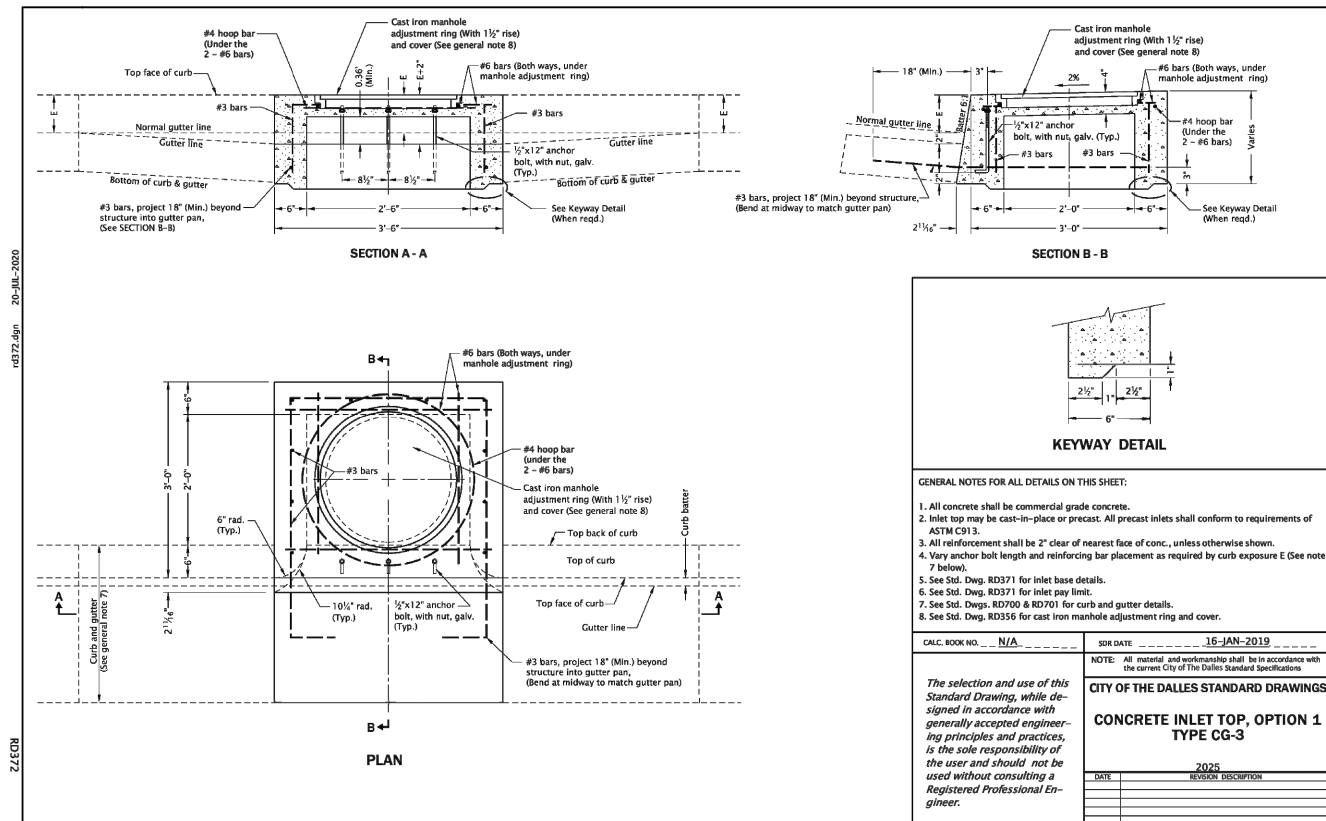

Effective Date: January 1, 2025 - December 31, 2025 RD372

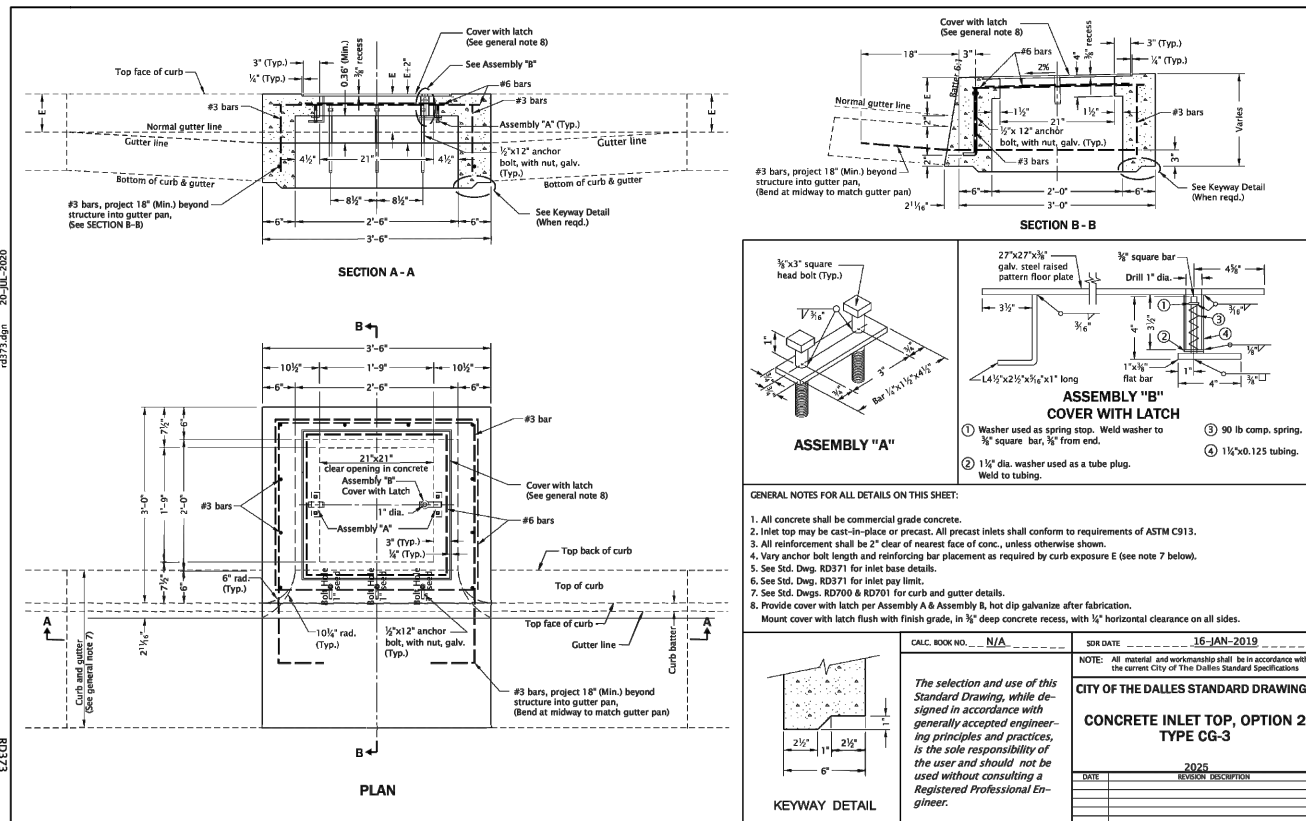

Effective Date: January 1, 2025 - December 31, 2025 RD373

NO.	DATE	REVISIONS

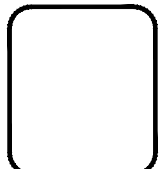

**CITY OF THE DALLES**  
 PUBLIC WORKS DEPARTMENT  
 1215 West First Street  
 The Dalles, Oregon 97058  
 (541) 296-6401



A DETAIL SHEET FOR:  
**WESTSIDE INTERCEPTOR UPGRADES - PHASE 2**  
 THE DALLES, OREGON

NAME	MHB
DATE	9/2/2025
SCALE	AS NOTED
CHECKED	
SHEET	C7.5
OF	31 SHEETS
JOB NO.	2025-010

**City of The Dalles Standard "H"-16"**  
**STANDARD CURB**  
(See general note 11)

**MOUNTABLE CURB**  
(See general note 11)

**CURB ENDING DETAIL**

**CURB AND GUTTER**

**MOUNTABLE CURB AND GUTTER**

**LOW PROFILE MOUNTABLE CURB AND GUTTER**  
(Where shown on plans)

**LOW PROFILE MOUNTABLE CURB**  
(See general note 11)

**MODIFICATION FOR KEYWAY**  
(Where shown on plans)

**WEEP HOLE DETAIL**  
(Where shown on plans)

**VALLEY GUTTER**

**GUTTER PAN NOTES:**  
Slope 5.0% normal.  
Slope 4.0% max. at curb ramps.  
Vary slope as req'd. for drainage.  
Vary where shown on plans.

**GENERAL NOTES FOR ALL DETAILS ON THIS SHEET:**

- Curb exposure "E" = 6" to 9", as measured vertically from flowline to highest point on curb. Vary as shown on plans or as directed. City of The Dalles standard "E" = 6".
- Const. curb expansion joints at 200' maximum spacing, and at points of tangency, and at ends of each driveway.
- Const. curb contraction joints at 15' maximum spacing, and at ends of each inlet and curb ramp.
- Transitions shall be used to connect curbs of different exposures "E".  
"E" is the total vertical dimension of those curb surfaces having a slope of 1:1 or steeper. Minimum desirable transition length shall be 20' for each 1" difference in "E".
- Top of all curbs shall slope toward the roadway at 1.5% max. (Max. 2.0% finished surface slope), unless otherwise shown, or as directed.
- Dimensions are nominal, vary to conform with curb machine approved by the engineer.
- Dimensions adjacent to radii are measured to the point of intersection of curb surfaces.
- For sidewalk details, and monolithic curb & sidewalk, see Std. Dwg. RD720 & RD721.
- For drainage curbs, see Std. Dwg. RD701.
- For curb ramp details, see Std. Dwg. RD900 series.
- Curb and gutter is required at curb ramp.

**NOTE:** The selection and use of this Standard Drawing, while designed in accordance with generally accepted engineering principles and practices, is the sole responsibility of the user and should not be used without consulting a Registered Professional Engineer.

**CITY OF THE DALLES STANDARD DRAWINGS**  
**CURBS**  
2025

DATE	REVISION DESCRIPTION

Effective Date: January 1, 2025 – December 31, 2025

**CONSTRUCTION ENTRANCE - TYPE 1**  
NOT TO SCALE

**CONSTRUCTION ENTRANCE - TYPE 2**  
NOT TO SCALE

**CONSTRUCTION ENTRANCE - TYPE 3 (TYPE 1 OR 2 WITH EXISTING CURB)**  
NOT TO SCALE

**WOODEN CURB RAMP SECTION D-D**  
NOT TO SCALE

**CONSTRUCTION ENTRANCE TABLE**  
MINIMUM LENGTH

Length (FT)	Area Of Exposed Soil (Acres)
20	0.25
50	0.25 < A < 1.0
100	A > 1.0

**CONSTRUCTION ENTRANCES**

**NOTES:**

- The Type 1 entrance is a simple entrance without a diversion ridge or settling basin.
- The wooden ramp may be used on either Type 1 or Type 2 entrances in situations where there is curb and the curb is not removed for the construction entrance.

**NOTE:** The selection and use of this Standard Drawing, while designed in accordance with generally accepted engineering principles and practices, is the sole responsibility of the user and should not be used without consulting a Registered Professional Engineer.

**CITY OF THE DALLES STANDARD DRAWINGS**  
**CONSTRUCTION ENTRANCES**  
2025

DATE	REVISION DESCRIPTION
Jan 2021	Removed Calc book numbers

Effective Date: January 1, 2025 – December 31, 2025

**WITH LANDSCAPED BUFFER STRIP**  
**OPTION "PR-1"**

**FOR WIDE SIDEWALKS**  
**OPTION "PR-2"**

**FOR NARROW SIDEWALKS**  
**OPTION "PR-3"**

**FOR NARROW SIDEWALKS**  
**OPTION "PR-4"**

**GENERAL NOTES FOR ALL DETAILS ON THIS SHEET:**

- Curb ramp details are based on applicable COTD Standards. See project plans for details not shown.
- See Std. Dwg. RD700 & RD701 for curbs.
- See Std. Dwg. RD720 & RD721 for sidewalks.
- See Std. Dwg. RD910 for perpendicular curb ramp details.
- See Std. Dwg. RD902 through RD908 for detectable warning surface installation details.
- Curb ramp slopes shown are relative to the true level horizon (zero bubble).
- Curb ramp slopes are immediately adjacent, the curb exposure (E) between the adjacent side flares may range between 3" and full design exposure.
- Grade breaks at the top and bottom of curb ramp runs shall be perpendicular to the direction of the ramp run. Grade breaks shall not be permitted on the surface of ramp runs and turning spaces. Surface slopes that meet at grade breaks shall be flush.
- Curb and gutter is required at curb ramps.

**LEGEND:**

- Marked or intended crossing location
- Sidewalk
- Detectable warning surface
- Level area (turning space/landing)  
Unobstructed 4.5' x 4.5'  
With obstruction 4.5' x 5.5' (longer dimension in direction of pedestrian street crossing).  
For the purposes of this application, a max. 2.0% finished surface slope (for drainage) measured perpendicular in two directions is considered level.
- Cross slope 1.5% max.  
(Max. 2.0% finished surface slope)  
(Normal sidewalk cross slope)
- Running slope 7.5% max.  
(Max. 8.3% finished surface slope)
- Flare slope  
(Max. 1.0% finished surface slope)
- Zero curb exposure
- 4' x 4' clear space
- PAR Pedestrian Access Route

**NOTE:** All material and workmanship shall be in accordance with the current City of The Dalles Standard Specifications.

**CITY OF THE DALLES STANDARD DRAWINGS**  
**PERPENDICULAR CURB RAMP**  
2025

DATE	REVISION DESCRIPTION

Effective Date: January 1, 2025 – December 31, 2025

**PLAN DITCH INLET**

**PLAN AREA DRAIN**

**SECTION A-A DITCH INLET**

**PLAN CATCH BASIN**

**BIOFILTER BAGS - TYPE 4**  
NOT TO SCALE

**INLET PROTECTION TYPE 4**

**NOTES:**

- Stake biofilter bags with 2"x2"x36" wood stakes, and use a minimum 2 stakes per bag. Drive stakes a minimum of 6" into the ground and flush with the top of the bags.
- Omit stakes when bags are placed on pavement surface.
- Overlap all bag joints 6".
- Biofilter bags used on active roadways are easily displaced and made ineffective if struck by vehicles. If struck by a cyclist, falls with injury could result. On active roadways alternative inlet protection should be considered.

**NOTE:** The selection and use of this Standard Drawing, while designed in accordance with generally accepted engineering principles and practices, is the sole responsibility of the user and should not be used without consulting a Registered Professional Engineer.

**CITY OF THE DALLES STANDARD DRAWINGS**  
**INLET PROTECTION TYPE 4**  
2025

DATE	REVISION DESCRIPTION
Jan 2021	Removed Calc book numbers

Effective Date: January 1, 2025 – December 31, 2025

NO.	DATE	REVISIONS

**CITY OF THE DALLES**  
PUBLIC WORKS DEPARTMENT  
1215 West First Street  
The Dalles, Oregon 97058  
(541) 296-6401

**THE PACIFIC NORTHWEST**  
**THE DALLES**  
OREGON

**WESTSIDE INTERCEPTOR UPGRADES - PHASE 2**  
THE DALLES, OREGON

A DETAIL SHEET FOR:

**NAME** MHB  
**DATE** 9/2/2025  
**SCALE** AS NOTED  
**CHECKED**  
**SHEET**  
**C7.6**  
**OF** 31 SHEETS  
**JOB NO.** 2025-010

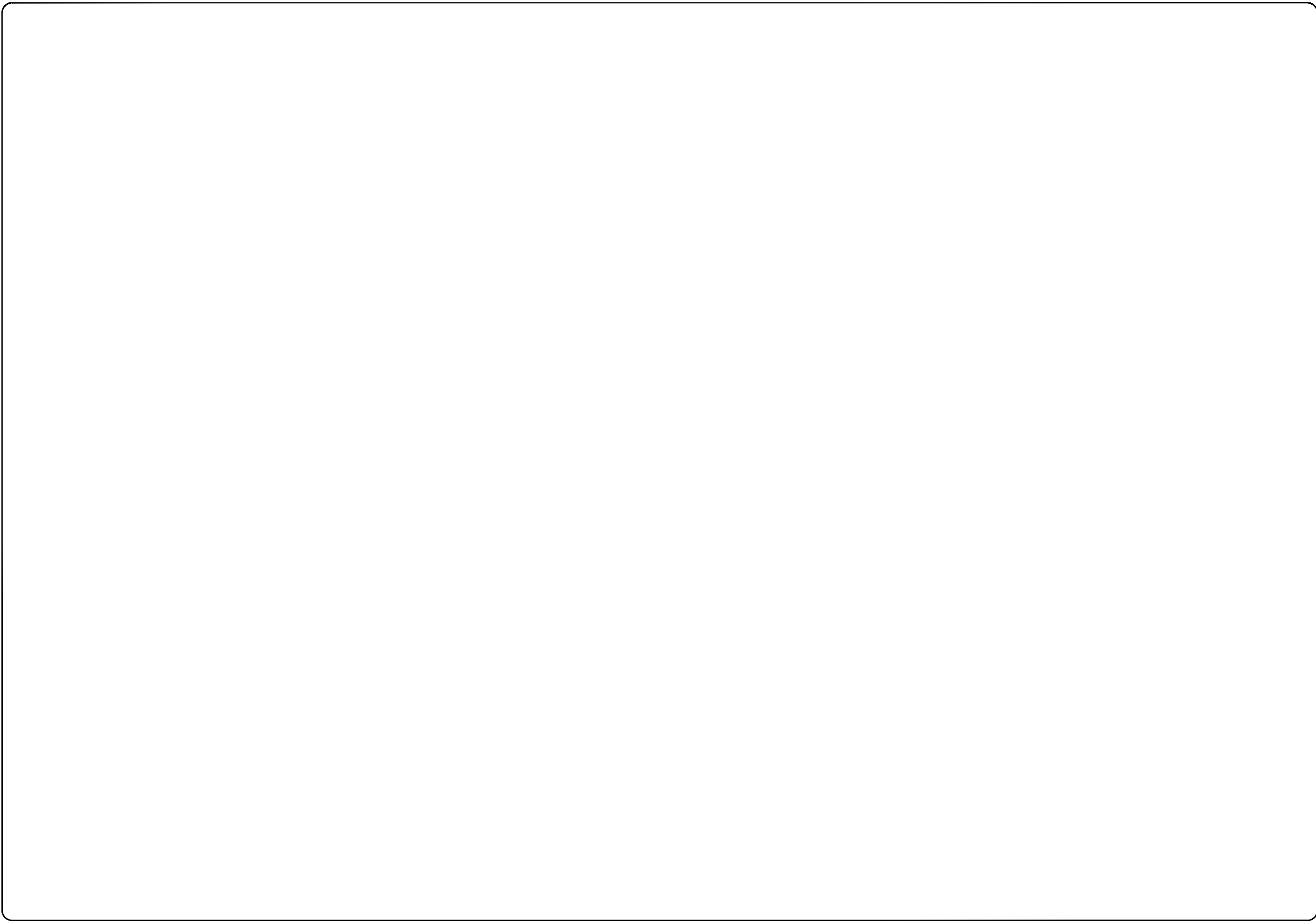

NAME	MHB
DATE	06/22/2020
SCALE	AS NOTED
CHECKED	
SHEET	
<b>C7.6</b>	
OF	21 SHEETS
JOB NO.	2020-010

A DETAIL SHEET FOR:  
**WESTSIDE INTERCEPTOR  
 UPGRADES - PHASE 1**  
 THE DALLES, OREGON



**CITY OF THE DALLES**  
 PUBLIC WORKS DEPARTMENT  
 1215 West First Street  
 The Dalles, Oregon 97058  
 (541) 296-6401

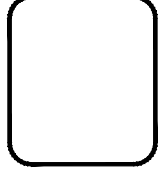

NO.	DATE	REVISIONS