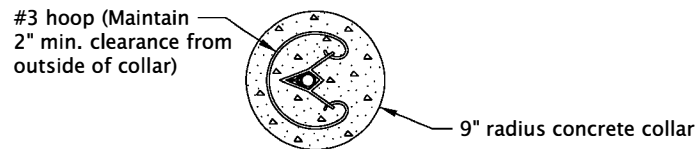
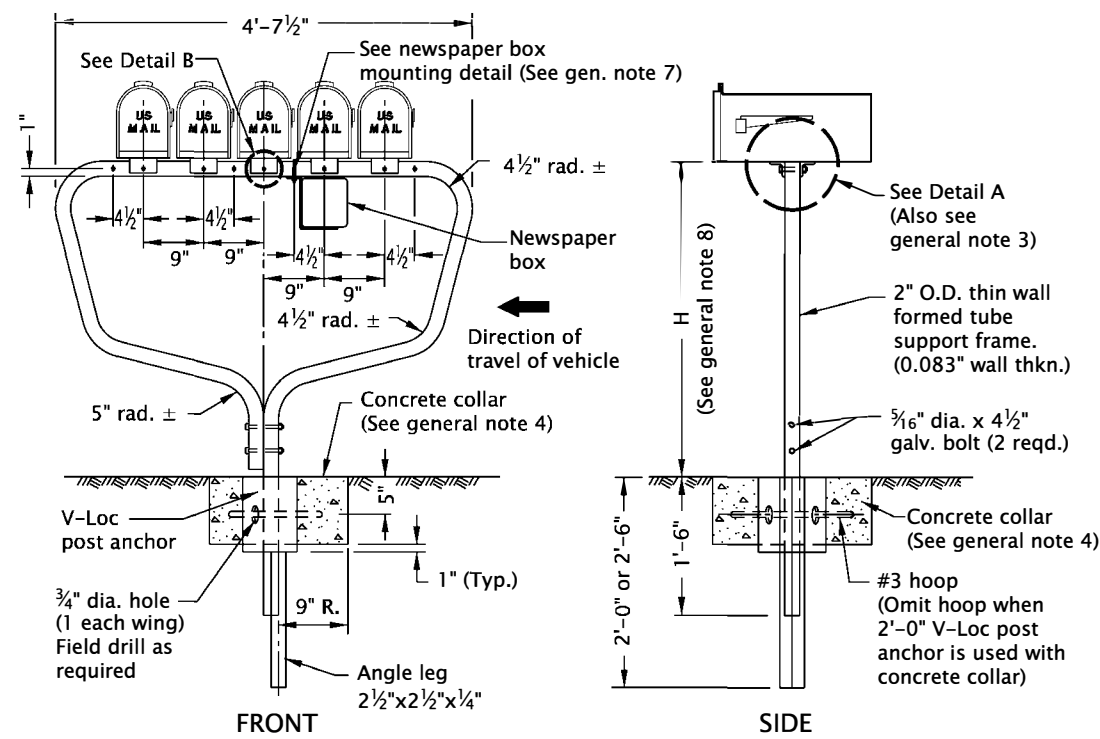


RD100.dgn 19-JAN-2024



CONCRETE COLLAR
(See general note 4)

MULTIPLE SUPPORT

(Supports 5 standard (Sizes 1 & 1 1/2) mailboxes or 4 large (Size 2) mailboxes)

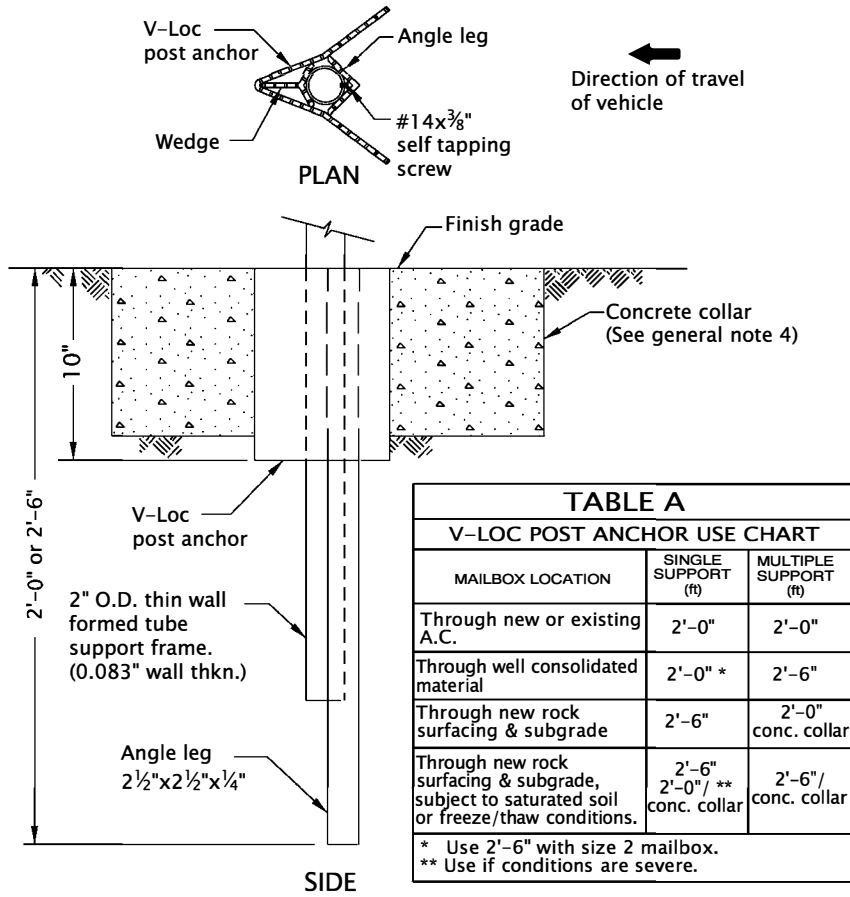
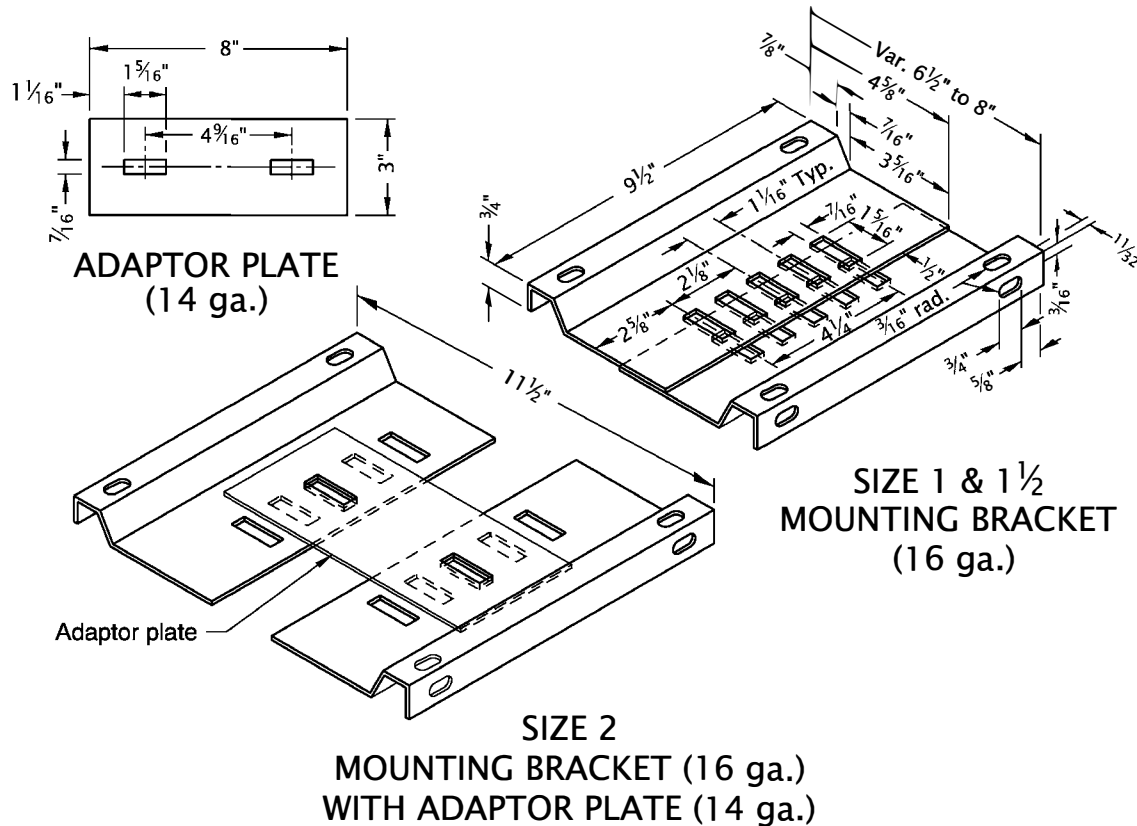
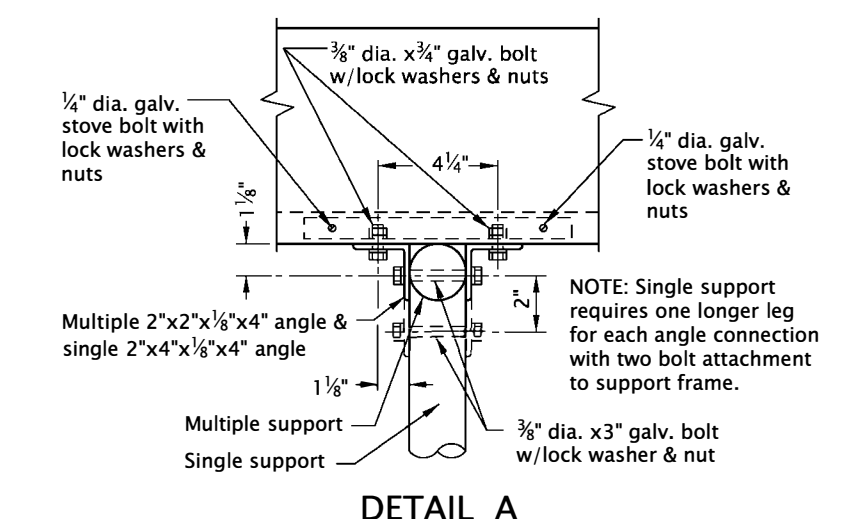


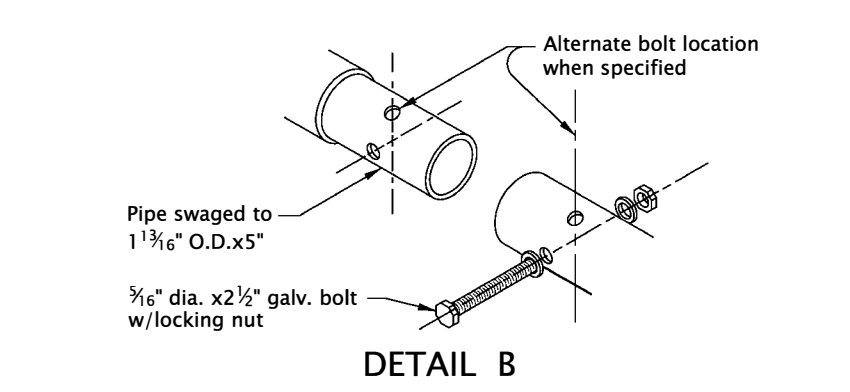
TABLE A V-LOC POST ANCHOR USE CHART		
MAILBOX LOCATION	SINGLE SUPPORT (ft)	MULTIPLE SUPPORT (ft)
Through new or existing A.C.	2'-0"	2'-0"
Through well consolidated material	2'-0" *	2'-6"
Through new rock surfacing & subgrade	2'-6"	2'-0" conc. collar
Through new rock surfacing & subgrade, subject to saturated soil or freeze/thaw conditions.	2'-6" 2'-0"/ **	2'-6"/ conc. collar

* Use 2'-6" with size 2 mailbox.
** Use if conditions are severe.

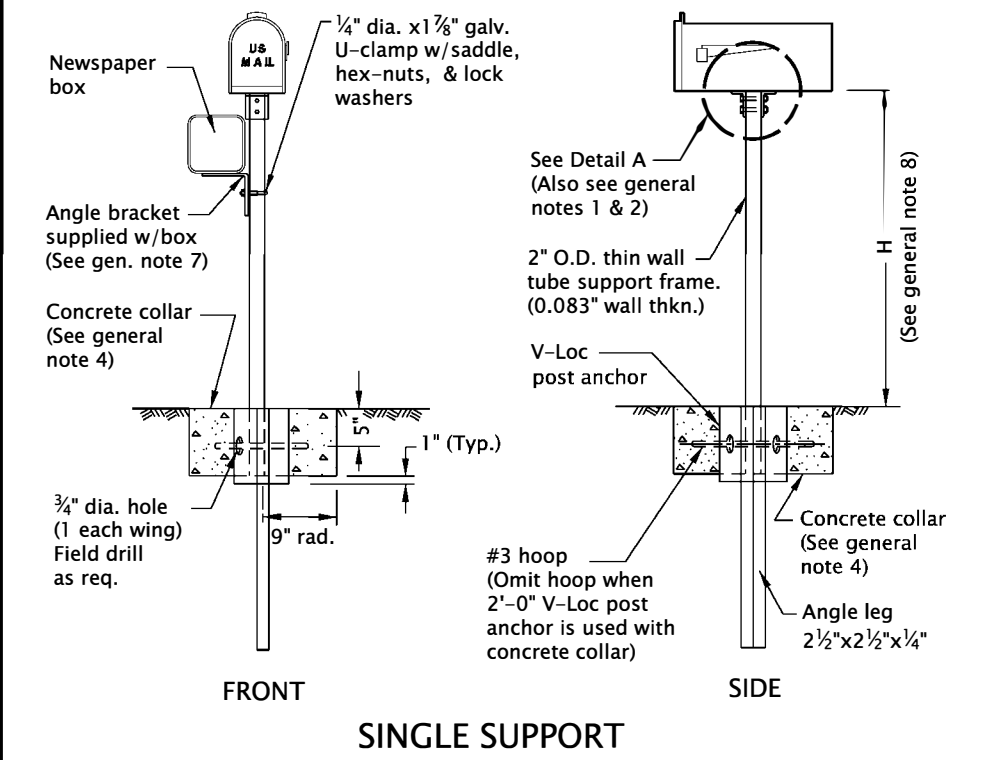
POST MOUNTING SOCKET



DETAIL A



DETAIL B



SINGLE SUPPORT

- GENERAL NOTES FOR ALL DETAILS ON THIS SHEET:**
- Angle connections to be parallel to traffic flow for Size 2 mailbox mounted on single post.
 - All holes in the tube support frame are to be predrilled by the manufacturer.
 - Size 2 mailbox mounted on a multiple support requires 2 each 3/8" dia. x 5/8" galv. bolts with lock washers and nuts to attach the adaptor plate to the mounting bracket. The unit will then require 4 angle connections to attach to the formed tube support frame. See Detail A.
 - Provide concrete collar when any of the following conditions exist:
 - when required in Table A
 - when required by project plans
 - as directed by the Engineer
 Concrete collar, when required, to be poured in place after V-Loc post anchor has been installed, level and plumb. Do not excavate below bottom of V-Loc post anchor. Care shall be taken that no concrete is placed within anchor.
 - Other proprietary products available as listed in ODOT's QPL.
 - For mailbox installation locations, see Std. Dwg. RD101 and project plans.
 - For Newspaper Box Mounting Detail, see Std. Dwg. RD101.
 - Mounting height (H) shall be from 41" Min. to 45" Max. (42" nominal), measured from vehicle driving surface.
 - See project plans for detail not shown.

The selection and use of this Standard Drawing, while designed in accordance with generally accepted engineering principles and practices, is the sole responsibility of the user and should not be used without first consulting a Registered Professional Engineer.

All materials shall be in accordance with the current City of The Dalles Standard Specifications.

CITY OF THE DALLES STANDARD DRAWINGS

MAILBOX SUPPORT

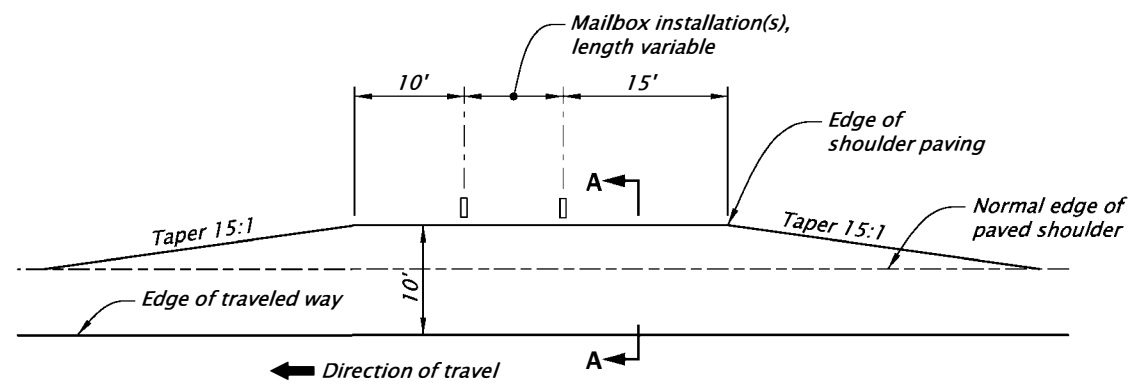
2025

DATE	REVISION	DESCRIPTION
12-2023	REVISED NOTES AND DETAILS	

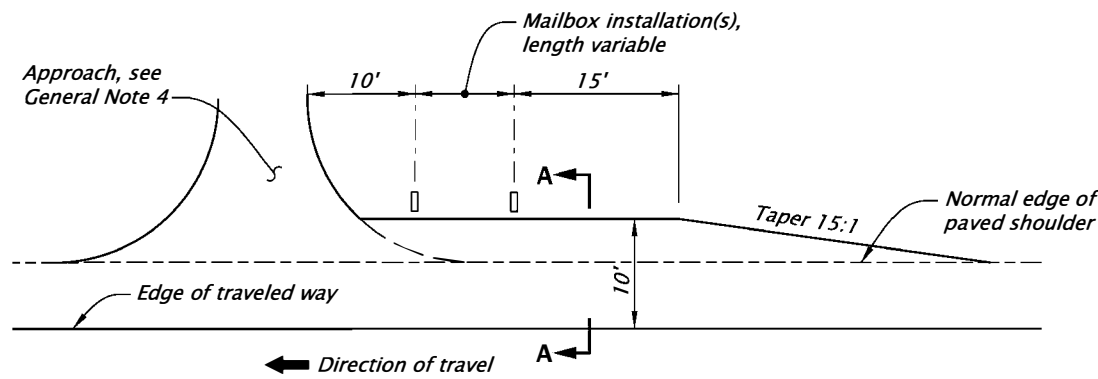
CALC. BOOK NO. - - -	N/A - - -	SDR DATE - 19-JAN-2024	RD100
----------------------	-----------	------------------------	--------------

GENERAL NOTES FOR ALL DETAILS ON THIS SHEET:

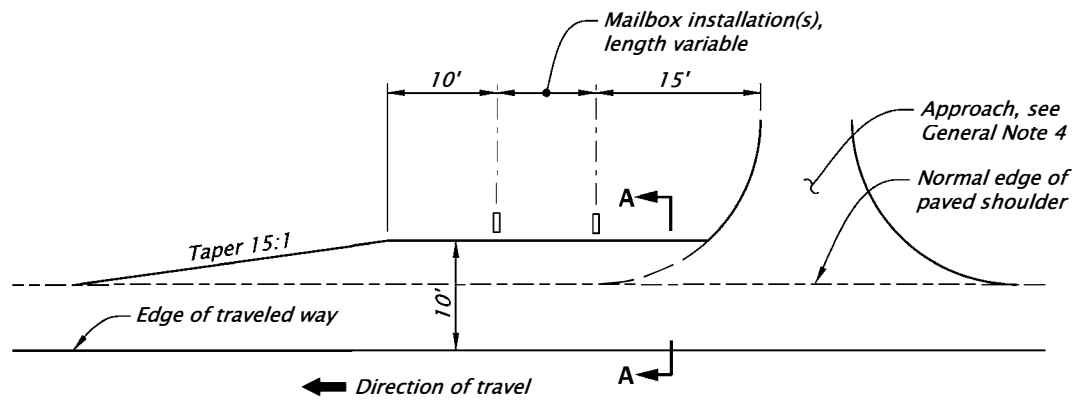
1. All holes in the tube support frame are to be predrilled by the manufacturer.
2. Other proprietary products available as listed in ODOT's QPL.
3. For mailbox support details, see Std. Dwg. RD100.
4. For approach details, see Std. Dwg. RD715.
5. Mounting height ("H") shall be from 41 inches minimum to 45 inches maximum (42 inches nominal), measured from vehicle driving surface.
6. See project plans for details not shown.



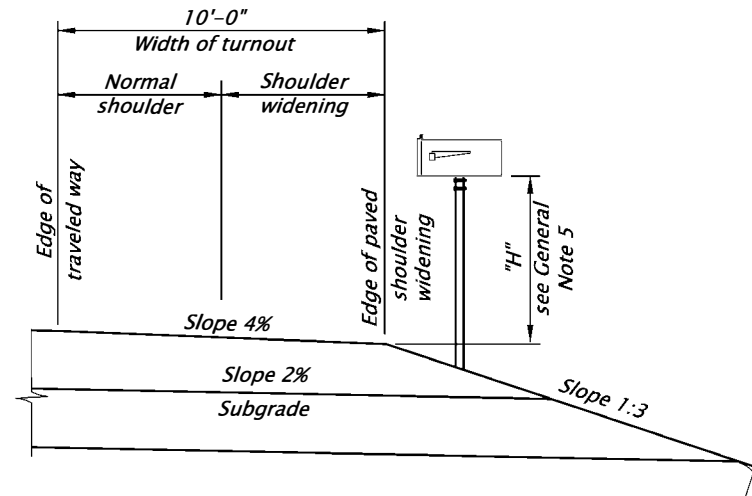
MAILBOX SERVICE TURNOUT



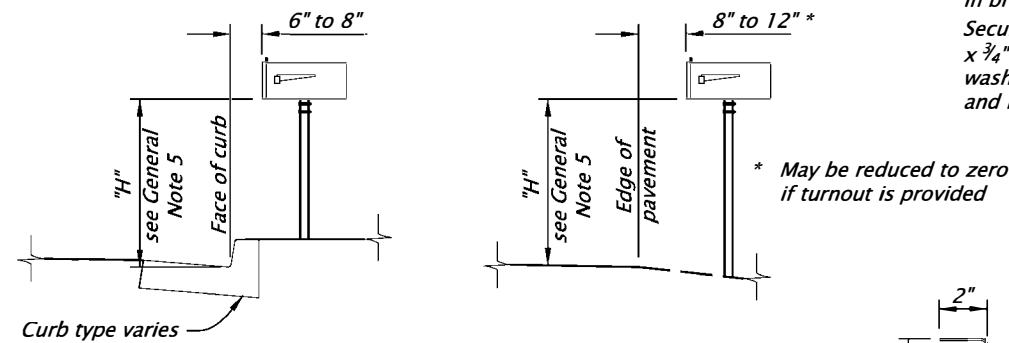
MAILBOX SERVICE TURNOUT BEFORE APPROACH



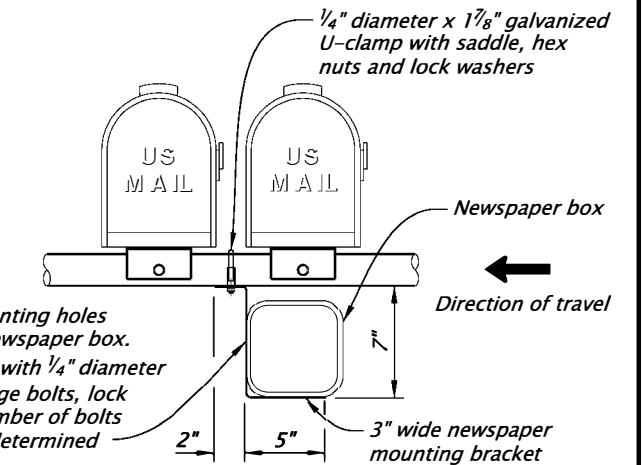
MAILBOX SERVICE TURNOUT AFTER APPROACH



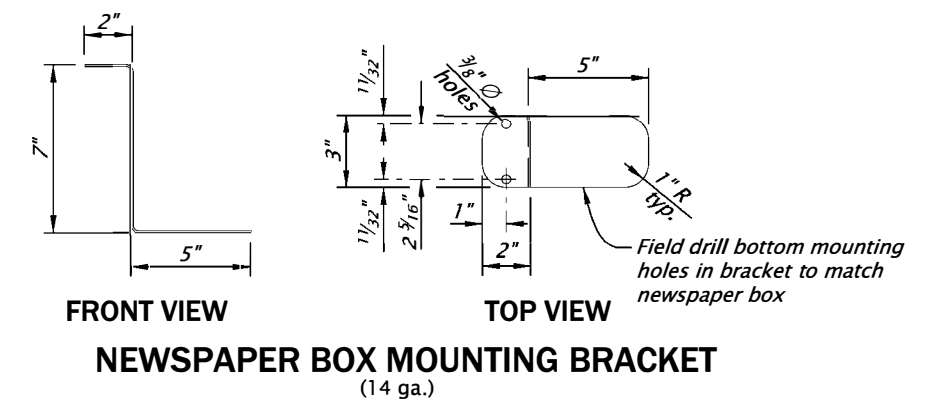
INSTALLATION AT MAILBOX TURNOUT SECTION A-A



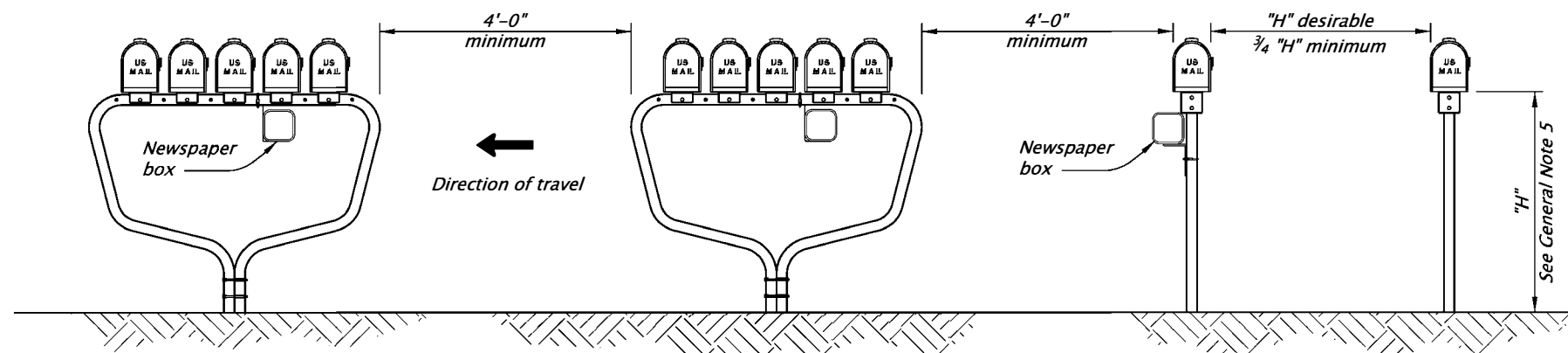
TYPICAL MAILBOX INSTALLATIONS



NEWSPAPER BOX MOUNTING DETAIL



NEWSPAPER BOX MOUNTING BRACKET (14 ga.)



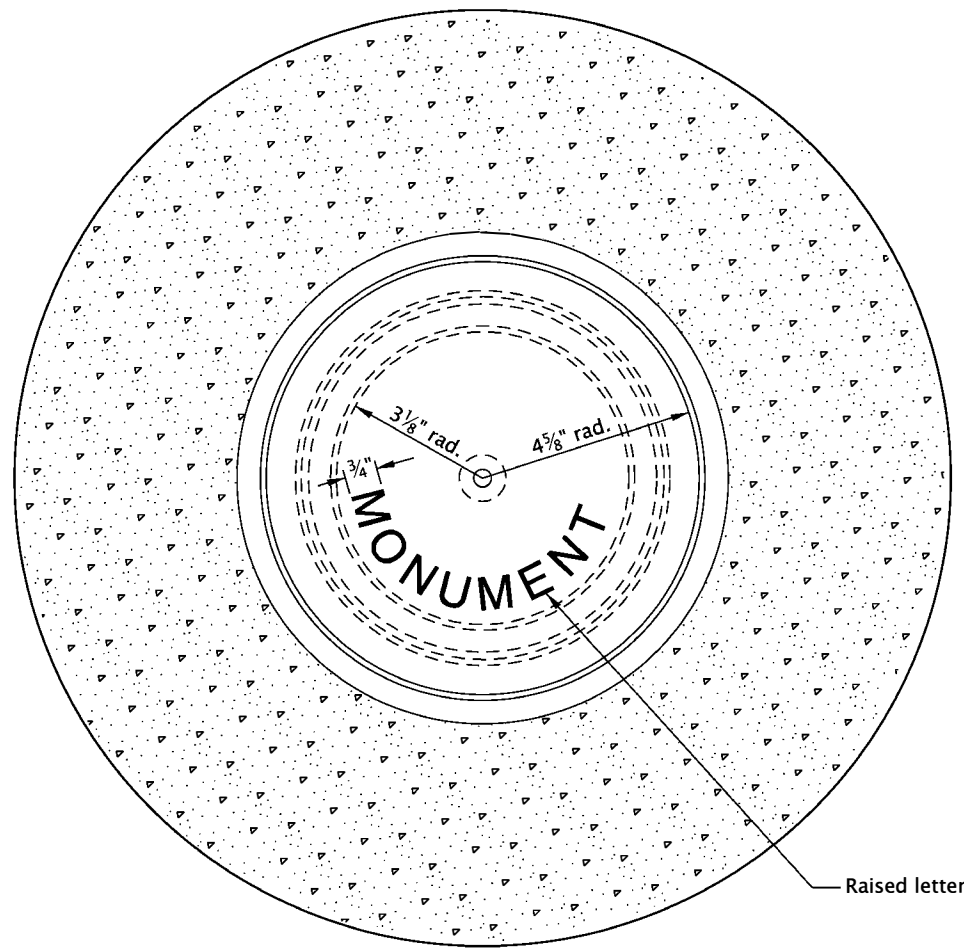
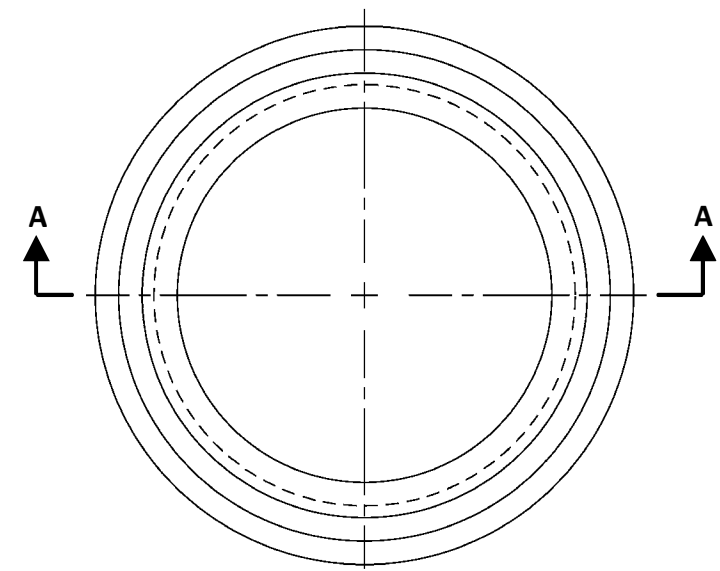
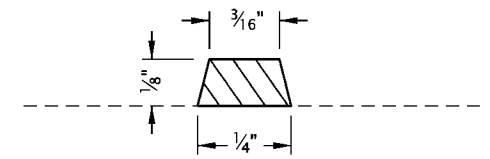
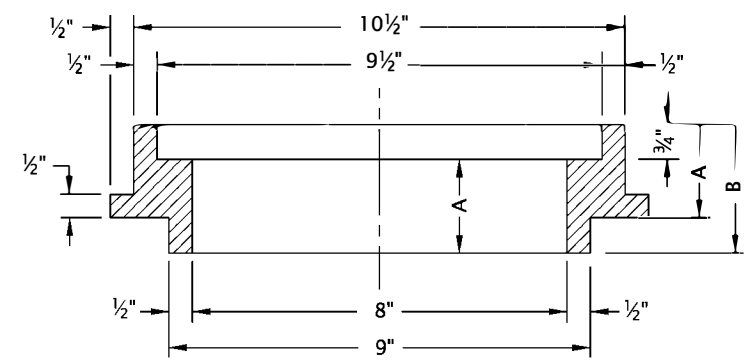
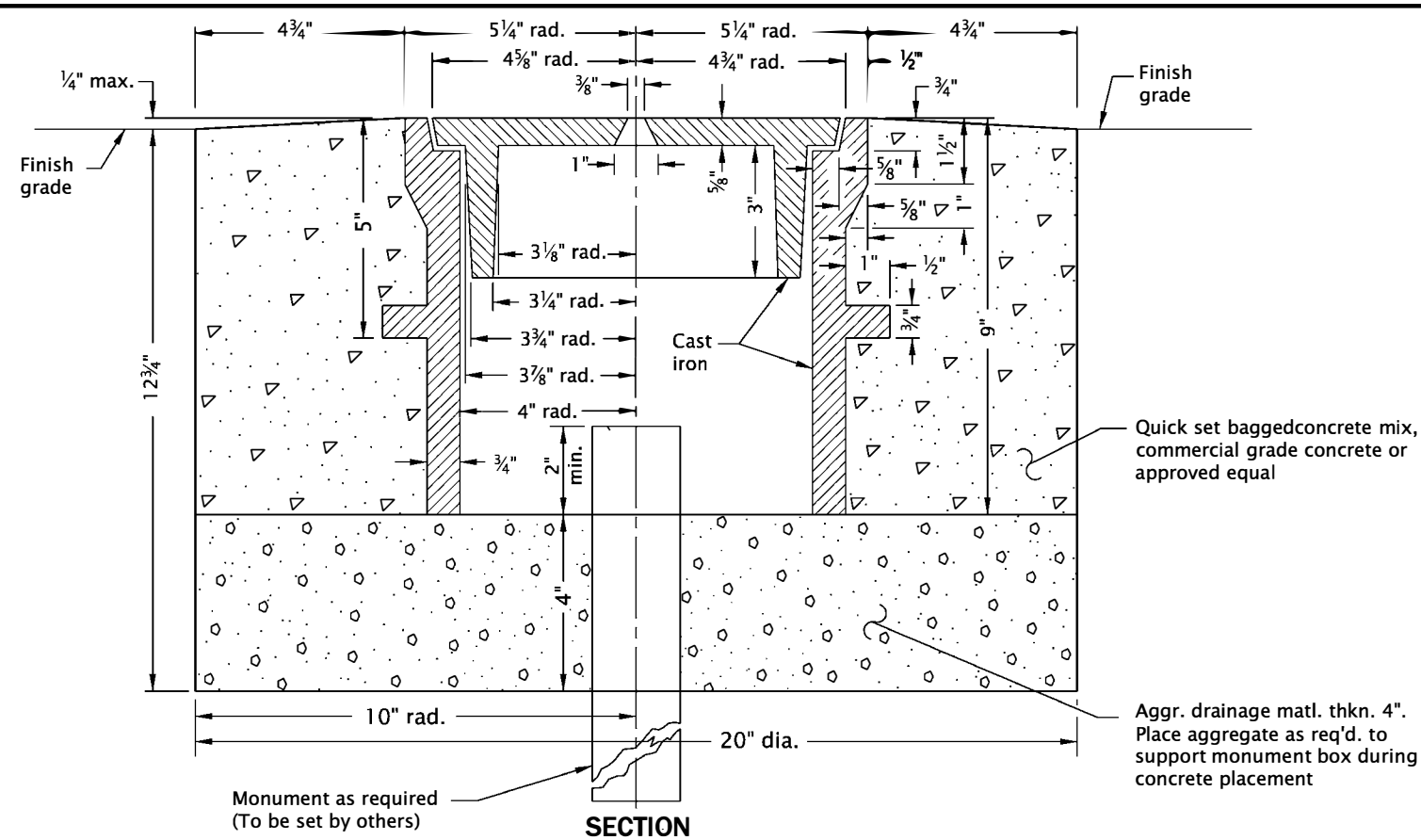
TYPICAL MAILBOX SUPPORT SPACING

The selection and use of this Standard Drawing, while designed in accordance with generally accepted engineering principles and practices, is the sole responsibility of the user and should not be used without first consulting a Registered Professional Engineer.

All materials shall be in accordance with the current City of The Dalles Standard Specifications.	
CITY OF THE DALLES STANDARD DRAWINGS	
MAILBOX INSTALLATION	
2025	
DATE	REVISION DESCRIPTION
01-2024	REVISED NOTES AND DETAILS, UPDATED DRAWING CAD STANDARDS
CALC. BOOK NO. - - - -	SDR DATE - 19-JAN-2024 - - - -
N/A	RD101

rd115.dgn 20-JUL-2020

RD115



SECTION A-A

SECTION OF RAISED LETTER

PLAN

RISER RING

RISER RING TABLE

RISER RING				
DIM.	ADJUSTMENT HEIGHT			
	1 1/2"	2"	2 1/2"	3"
A	1 1/2"	2"	2 1/2"	3"
B	2 1/4"	2 3/4"	3 1/4"	3 3/4"

GENERAL NOTES FOR ALL DETAILS ON THIS SHEET:

- See project plans for details not shown.

CALC. BOOK NO. N/A

SDR DATE 25-JUL-2017

NOTE: All material and workmanship shall be in accordance with the current city of The Dalles standard specifications

CITY OF THE DALLES STANDARD DRAWINGS

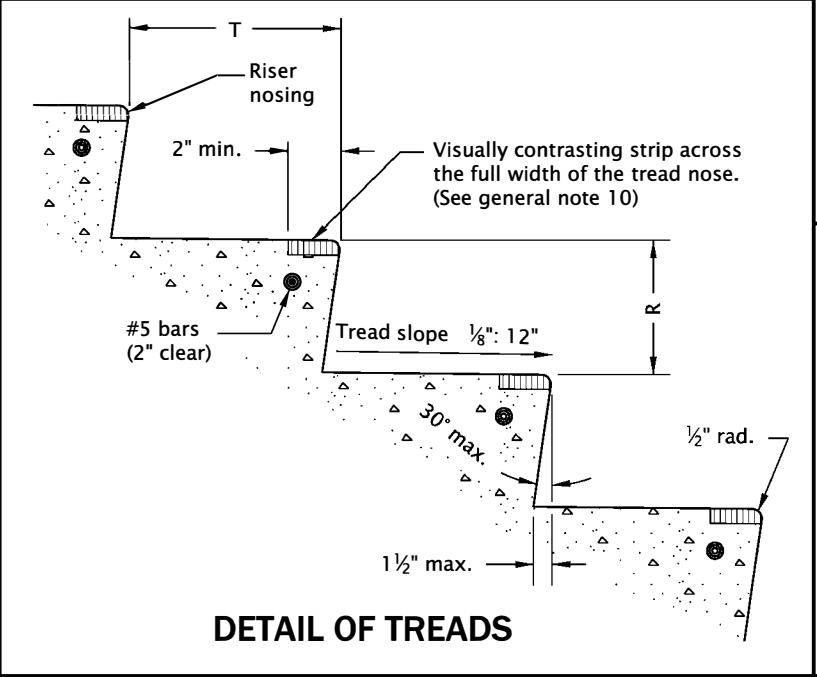
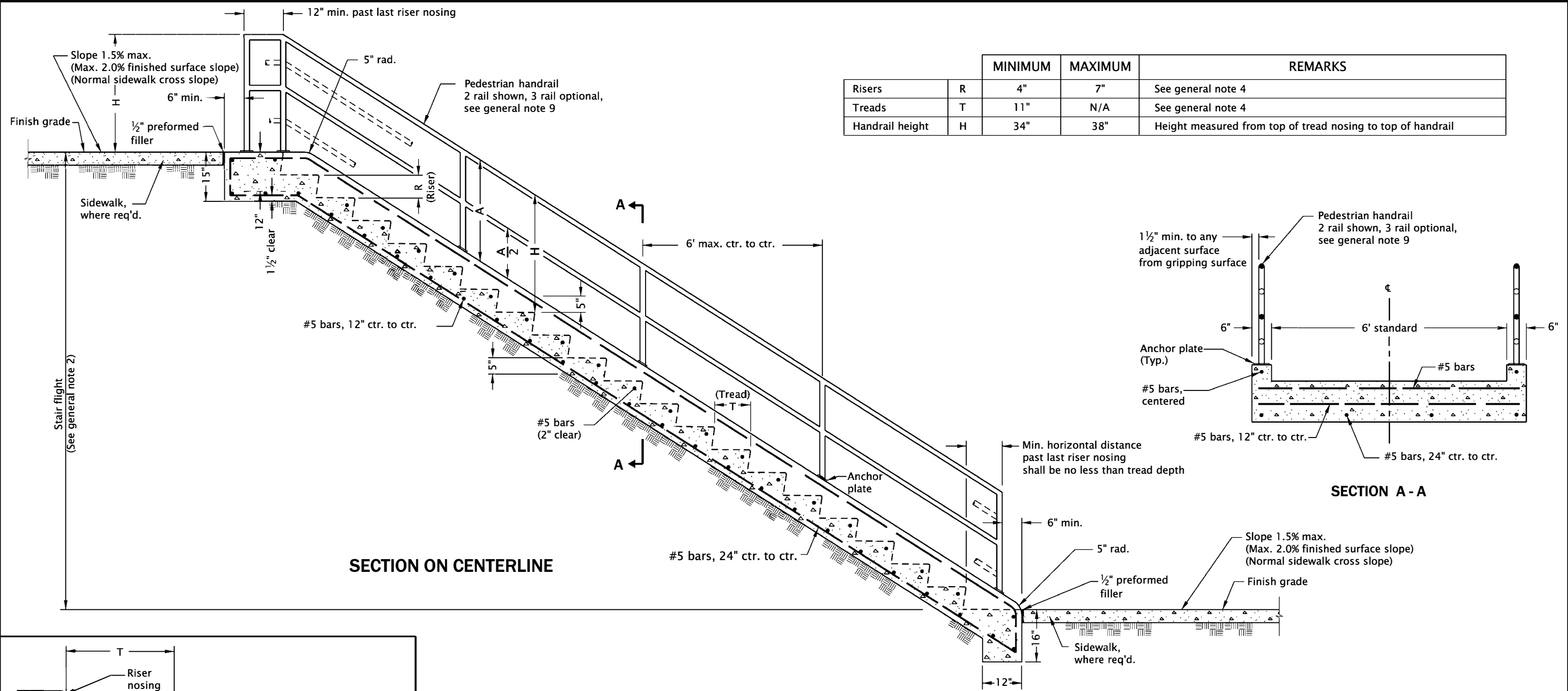
MONUMENT BOX

2025

DATE	REVISION	DESCRIPTION

rd120.dgn 20-JUL-2020

RD120

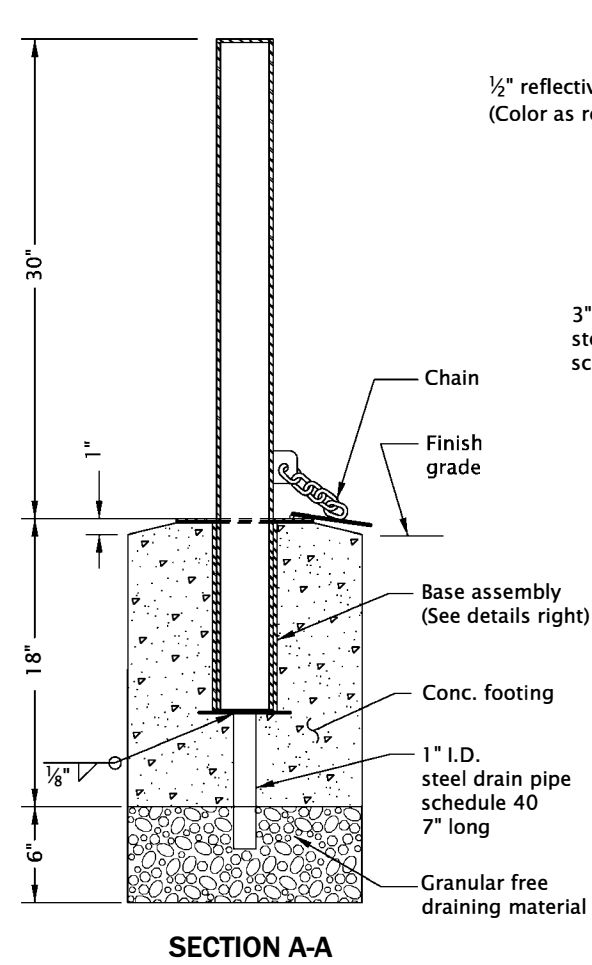


- GENERAL NOTES FOR ALL DETAILS ON THIS SHEET:**
- Details are based on United States Access Board Standards.
 - Maximum vertical rise between finish grade of landings shall be 12'.
 - Number of steps varies. Round edges of steps and all other exposed edges to 1/2" radius.
 - All risers in a stair flight shall be the same height.
All treads in a stair flight shall be the same depth.
 - Handrail height (H) to be constant within a stair flight.
 - All concrete shall be commercial grade concrete.
 - All reinforcing steel to be placed a minimum of 2" clear of nearest face of concrete unless otherwise shown or noted.
 - See Std. Dwg. RD720 for sidewalk details.
 - See Std. Dwgs. RD770 & RD771 for pedestrian handrail details.
 - Provide painted contrasting strip (color shall be safety yellow), or approved equal.
 - See project plans for details not shown.

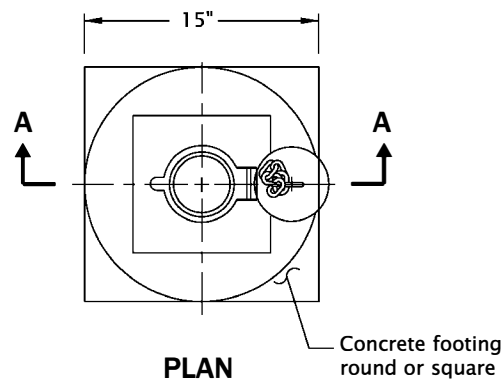
CALC. BOOK NO. N/A

The selection and use of this Standard Drawing, while designed in accordance with generally accepted engineering principles and practices, is the sole responsibility of the user and should not be used without consulting a Registered Professional Engineer.

SDR DATE	16-JAN-2018
NOTE:	All material and workmanship shall be in accordance with the current City of The Dalles Standard Specifications
CITY OF THE DALLES STANDARD DRAWINGS	
CONCRETE STAIRWAY	
2025	
DATE	REVISION DESCRIPTION



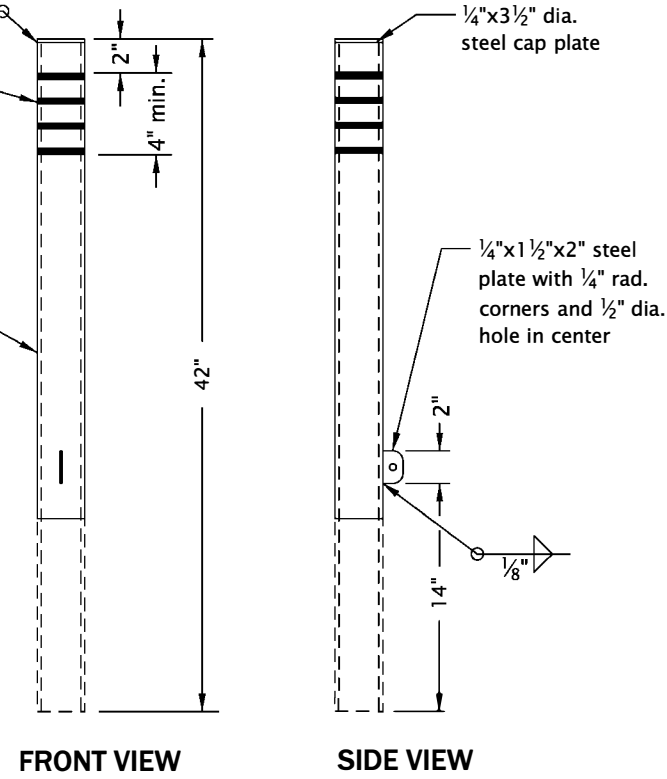
SECTION A-A



PLAN

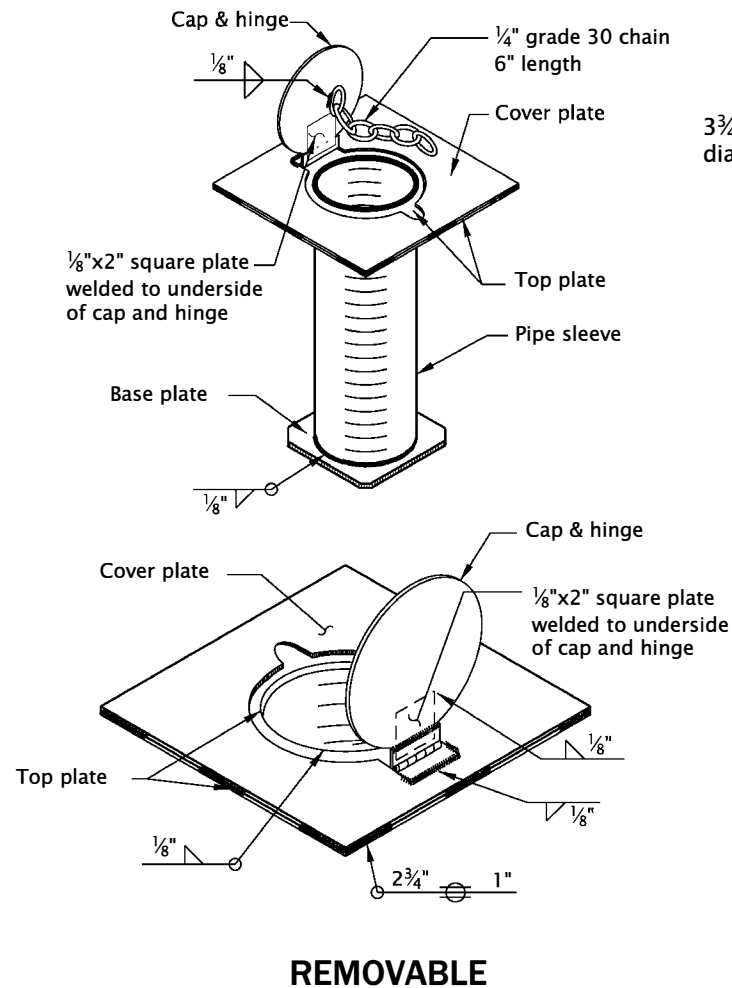
GENERAL NOTES FOR ALL DETAILS ON THIS SHEET:

1. Grind all edges smooth.
2. Prime and paint bollard safety yellow after fabrication.
3. Hot-dip galvanize base assembly after fabrication.
4. All concrete shall be commercial grade concrete.
5. Orient lock assembly parallel with pedestrian traffic.
6. Provide lock, if required.
7. See project plans for details not shown.

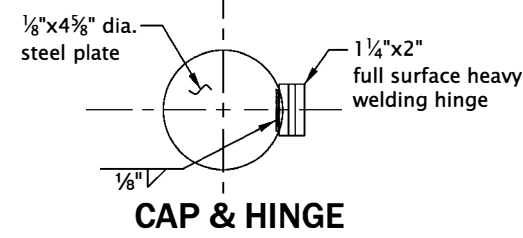


FRONT VIEW

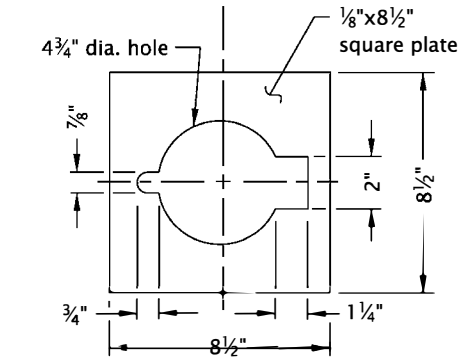
SIDE VIEW



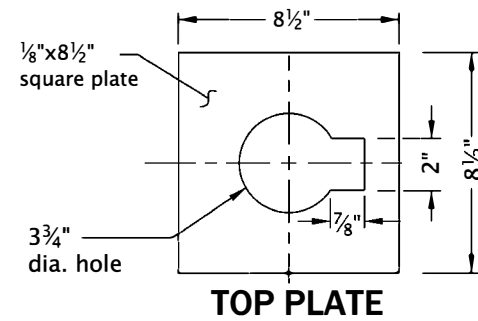
REMOVABLE



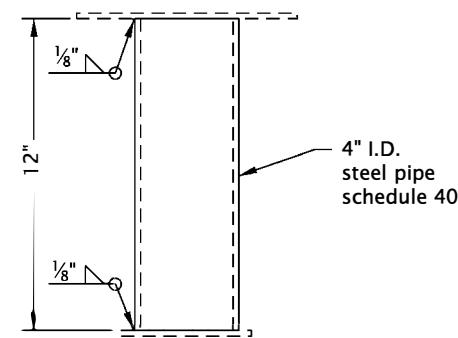
CAP & HINGE



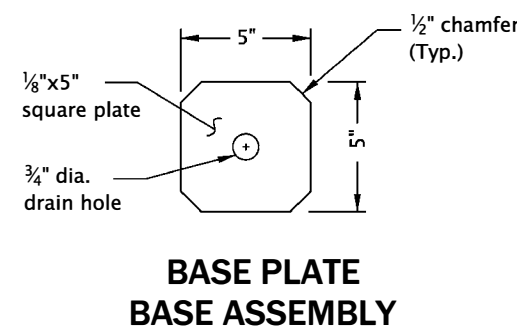
COVER PLATE



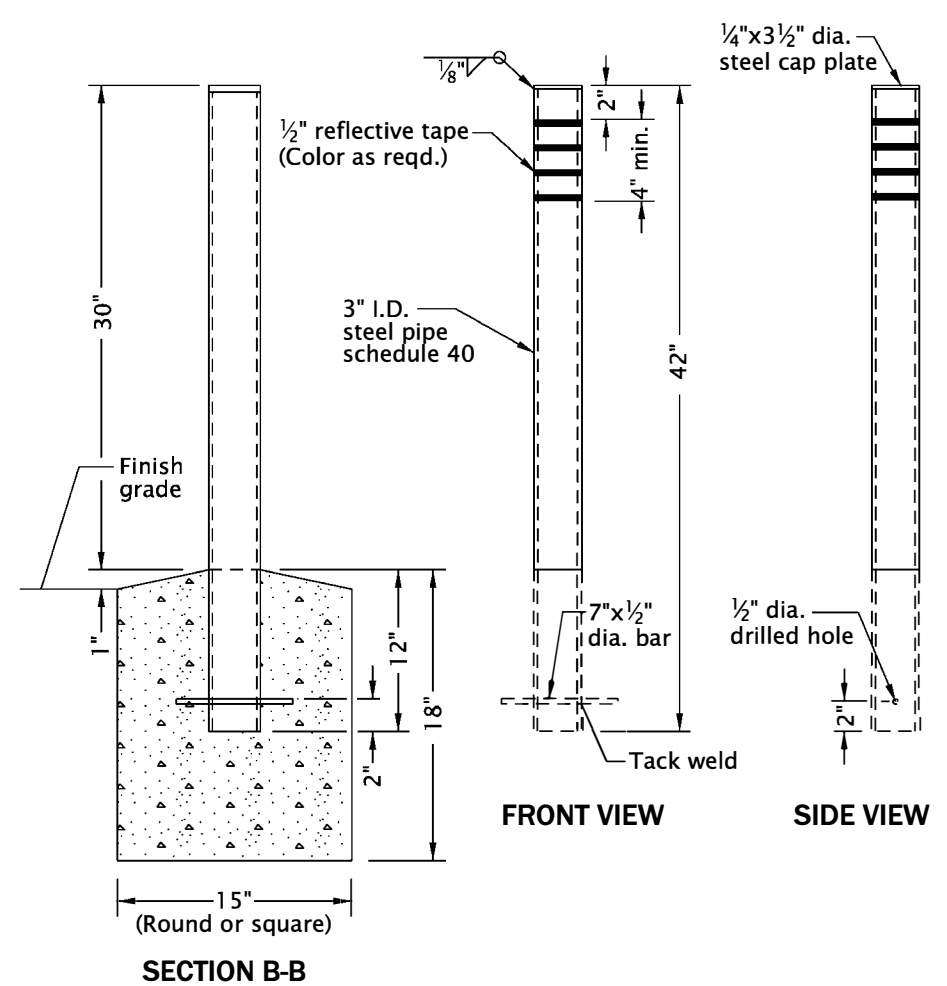
TOP PLATE



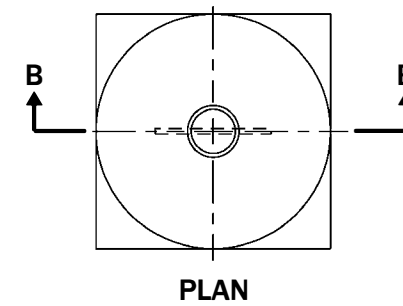
PIPE SLEEVE



BASE PLATE BASE ASSEMBLY



SECTION B-B



PLAN

NON-REMOVABLE

CALC. BOOK NO. N/A SDR DATE 25-JUL-2017

NOTE: All material and workmanship shall be in accordance with the current Oregon Standard Specifications

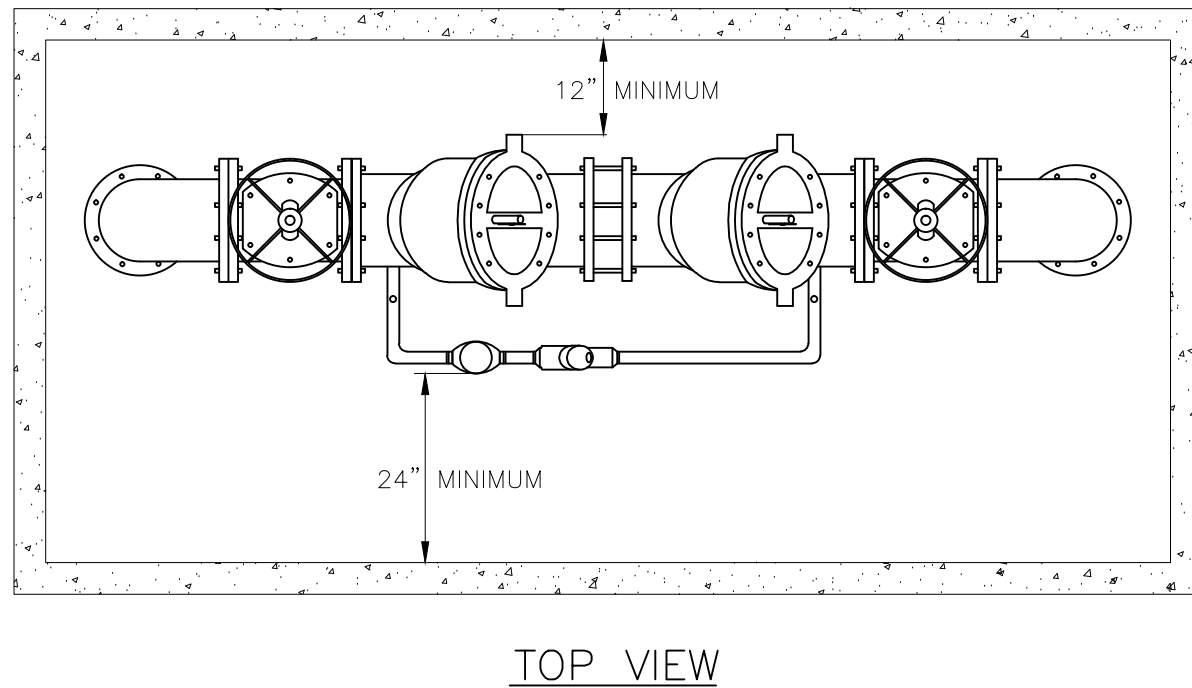
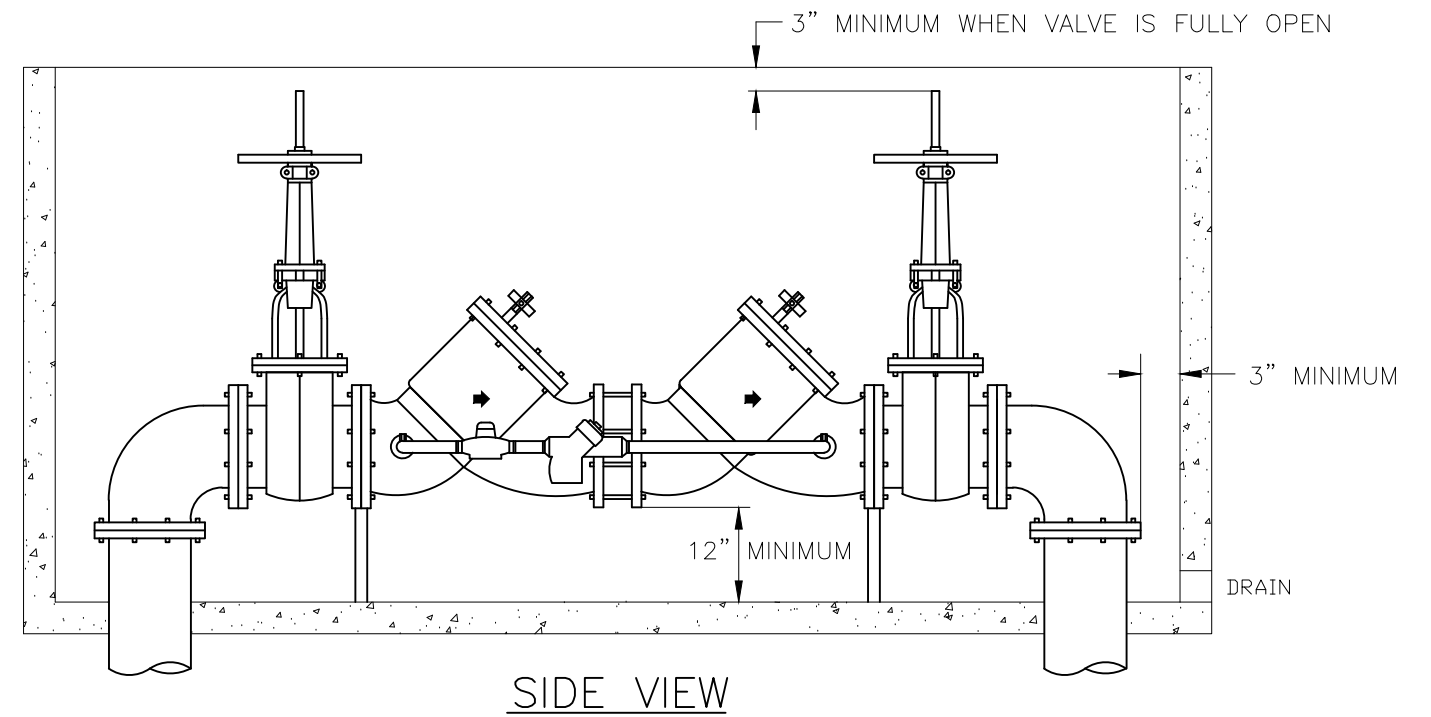
OREGON STANDARD DRAWINGS

BOLLARDS

2025

DATE	REVISION	DESCRIPTION

The selection and use of this Standard Drawing, while designed in accordance with generally accepted engineering principles and practices, is the sole responsibility of the user and should not be used without consulting a Registered Professional Engineer.

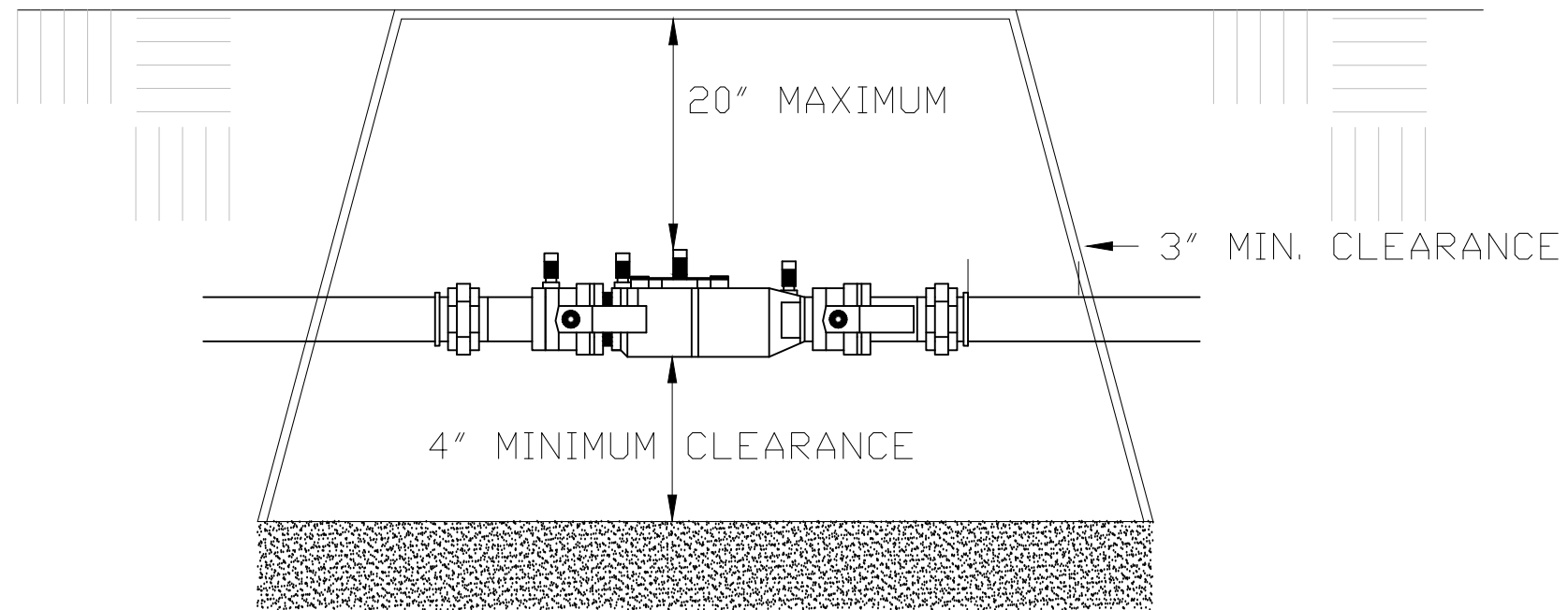


NOTES:

1. LID IS TO BE SPRING LOADED AND ABLE TO LOCK IN THE OPEN POSITION.
2. ASSEMBLY MUST BE FREEZE PROTECTED
3. ALL BELOW GROUND AND VAULT INSTALLATIONS SHALL HAVE NON-GALVANIZED, THREADED, AND WATER-TIGHT FITTED PLUGS OR CAPS ON THE TEST PORTS.
4. RPDA ASSEMBLIES MUST NOT BE INSTALLED IN AN ENCLOSED VAULT OR BOX UNLESS A BORE-SIGHTED DRAIN TO DAYLIGHT IS PROVIDED.

<p>The selection and use of this Standard Drawing, while designed in accordance with generally accepted engineering principles and practices, is the sole responsibility of the user and should not be used without consulting a Registered Professional Engineer.</p>	NOTE: All material and workmanship shall be in accordance with with the current Oregon Standard Specifications	
	CITY OF THE DALLES STANDARD DRAWING	
	DOUBLE CHECK DETECTOR ASSEMBLY (DCDA) OR REDUCED PRESSURE DETECTOR (RPDA) INSTALLATION 2025	
	REVISIONS	
	DATE	DESCRIPTION

Effective Date: January 1, 2025 - December 31, 2025 RD2111



TYPICAL BELOW GROUND INSTALLATION

<u>RECOMMENDED ENCLOSURE SIZES</u>	
<u>SERVICE SIZE</u>	<u>BOX SIZE</u>
3/4" TO 1" ———	14" X 19"
1-1/2" TO 2" ———	17" X 30"

NOTES:

1. CANNOT BE SUBJECTED TO CONTINUANCE FLOODING.
2. ASSEMBLY MUST BE FREEZE PROTECTED
3. TEST COCKS FITTED WITH WATER TIGHT PLUGS

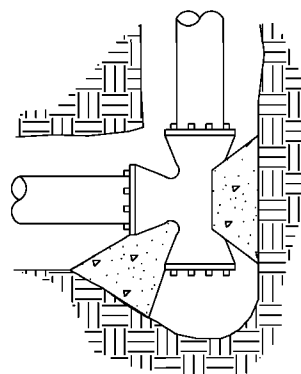
<p>The selection and use of this Standard Drawing, while designed in accordance with generally accepted engineering principles and practices, is the sole responsibility of the user and should not be used without consulting a Registered Professional Engineer.</p>	NOTE: All material and workmanship shall be in accordance with with the current City of The Dalles Standard Specifications					
	<p>CITY OF THE DALLES STANDARD DRAWING</p> <p>DOUBLE CHECK VALVE ASSEMBLY BELOW GROUND 2" AND SMALLER</p> <p>2025</p>					
	<p>REVISIONS</p> <table border="1"> <thead> <tr> <th>DATE</th> <th>DESCRIPTION</th> </tr> </thead> <tbody> <tr> <td> </td> <td> </td> </tr> </tbody> </table>		DATE	DESCRIPTION		
	DATE	DESCRIPTION				

THRUST BLOCKING

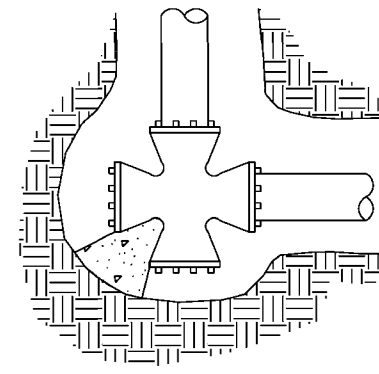
TABLE A						
CONCRETE THRUST BLOCKING (HORIZONTAL)						
		Thrust (T) at fittings in Pounds				
PIPE DIA.	Table Pressure PSI	Tee & Dead Ends	90 deg Bend	45 deg Bend	22.5 deg Bend	11.25 deg Bend
4"	250	3035	4320	2315	1215	610
6"	250	6860	9735	5215	2720	1375
8"	250	12185	17310	9265	4835	2430
10"	250	19045	27045	14480	7560	3800
12"	250	27405	38940	20840	10880	5465
14"	250	37320	53010	28370	14815	7445
16"	250	48740	69245	37050	19360	9735

TABLE B	
Soil Type	Soil Bearing Capacity (B) in PSF
Muck, peat, etc.	0
Soft Clay	1000
Sand	2000
Sand and gravel	3000
Sand and gravel cemented with clay	4000
Hard shale	10,000

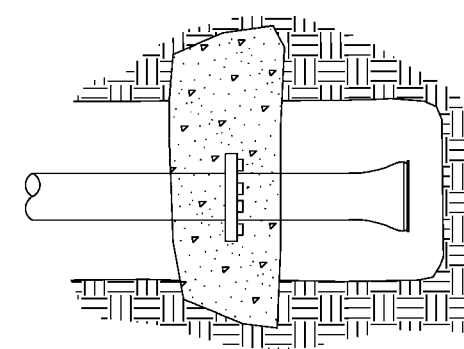
TABLE C							
CONCRETE BLOCKING FOR CONVEX VERTICAL BENDS							
DIMENSION TABLE							
PIPE DIA. in.	Table Pressure PSI	Bend Angle (deg)	Concrete Volume (cy)	Cube Size (ft)	Stirrup Dia. (in)	Stirrup Embmt. (in)	Stirrup Bar #
4"	250	11.25	0.21	1.8	5/8	17	5
		22.5	0.43	2.3			
		45	0.77	2.8			
6"	250	11.25	0.48	2.4	5/8	17	5
		22.5	0.95	3.0			
		45	1.79	3.6			
8"	250	11.25	0.86	2.9	5/8	17	5
		22.5	1.65	3.5			
		45	3.22	4.4			
10"	250	11.25	1.39	3.3	5/8	17	5
		22.5	2.62	4.1			
		45	4.97	4.1			
12"	250	11.25	1.94	3.7	5/8	17	5
		22.5	3.91	4.7			
		45	6.89	5.7			
14"	250	11.25	2.62	4.1	5/8	17	5
		22.5	5.26	5.2			
		45	9.70	6.4			
16"	250	11.25	3.44	4.5	5/8	17	5
		22.5	6.89	5.7			
		45	12.63	7.0			
					1/8	30	9



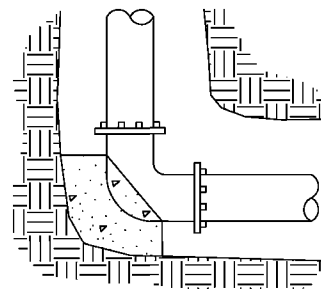
TEE



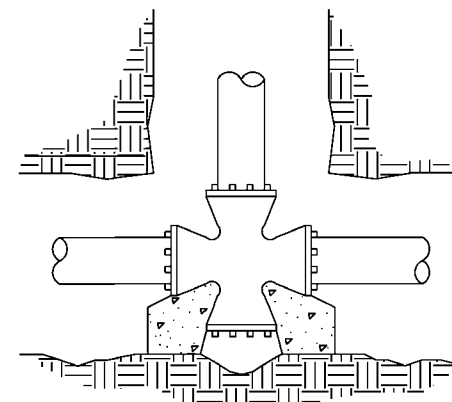
CROSS



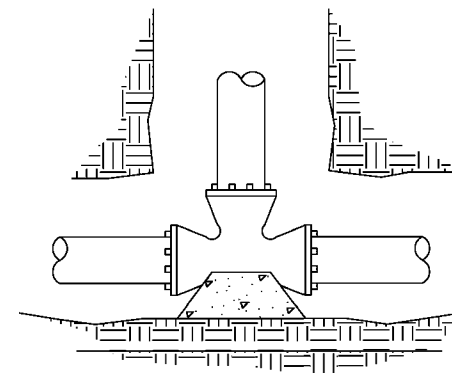
STRADDLE



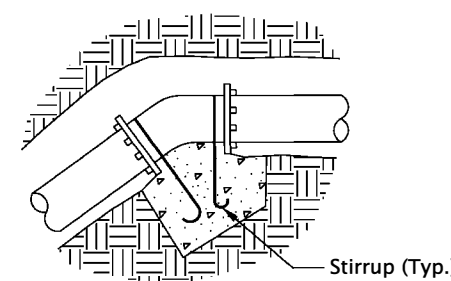
BEND



CROSS

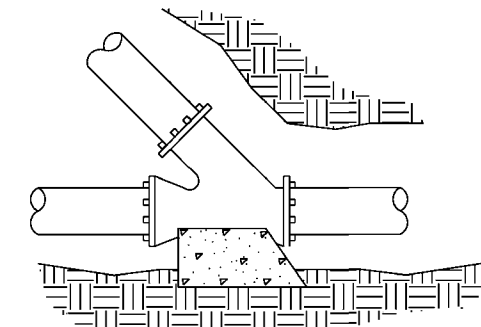


TEE



CONVEX VERTICAL BEND

(See Table C)



WYE

THRUST BLOCK BEARING AREA EQUATION

NOTE: WHEN THRUST BLOCK BEARING AREA IS NOT SPECIFIED ON THE PLANS OR DETERMINED BY THE ENGINEER, USE THE FOLLOWING PROCEDURE TO DETERMINE REQUIRED BEARING AREA.

1. Determine thrust (T) for type of fitting or joint and size of pipe from Table A.
2. Determine Design (Test) Pressure from Standard Specifications or Special Provisions.
3. Determine Table Pressure from Table A.
4. Determine Soil Bearing Capacity (B) of soil from Table B.
5. Determine required bearing area (A) in sq. ft. as follows:

$$\text{Thrust Block Bearing Area} = A = \left(\frac{T}{B} \right) \left(\frac{\text{Design (Test) Pressure}}{\text{Table Pressure}} \right)$$

Example: Design (Test) Pressure = 150 PSI From Table A, T = 37320
 Pipe = 14" From Table B, B = 2000
 Fitting = Tee
 Soil = Sand
 $A = \left(\frac{37320}{2000} \right) \left(\frac{150}{250} \right) = 11.2 \text{ sq.ft.}$

GENERAL NOTES FOR ALL DETAILS ON THIS SHEET:

1. Contractor to provide blocking adequate to withstand full test pressure.
2. Pour concrete blocking against undisturbed earth.
3. All concrete shall be commercial grade concrete.
4. Wrap pipe and/or fittings with 2 layers of polyethylene film where in contact with concrete
5. Keep concrete clear of all joints and accessories.
6. Stirrups shall be deformed galvanized cold rolled steel AASHTO M31 (ASTM A615), Grade 60. Coat with coal tar epoxy after installation.
7. See project plans for details not shown.

CALC. BOOK NO. N/A

SDR DATE 25-JUL-2017

NOTE: All material and workmanship shall be in accordance with the current City of The Dalles Standard Specifications

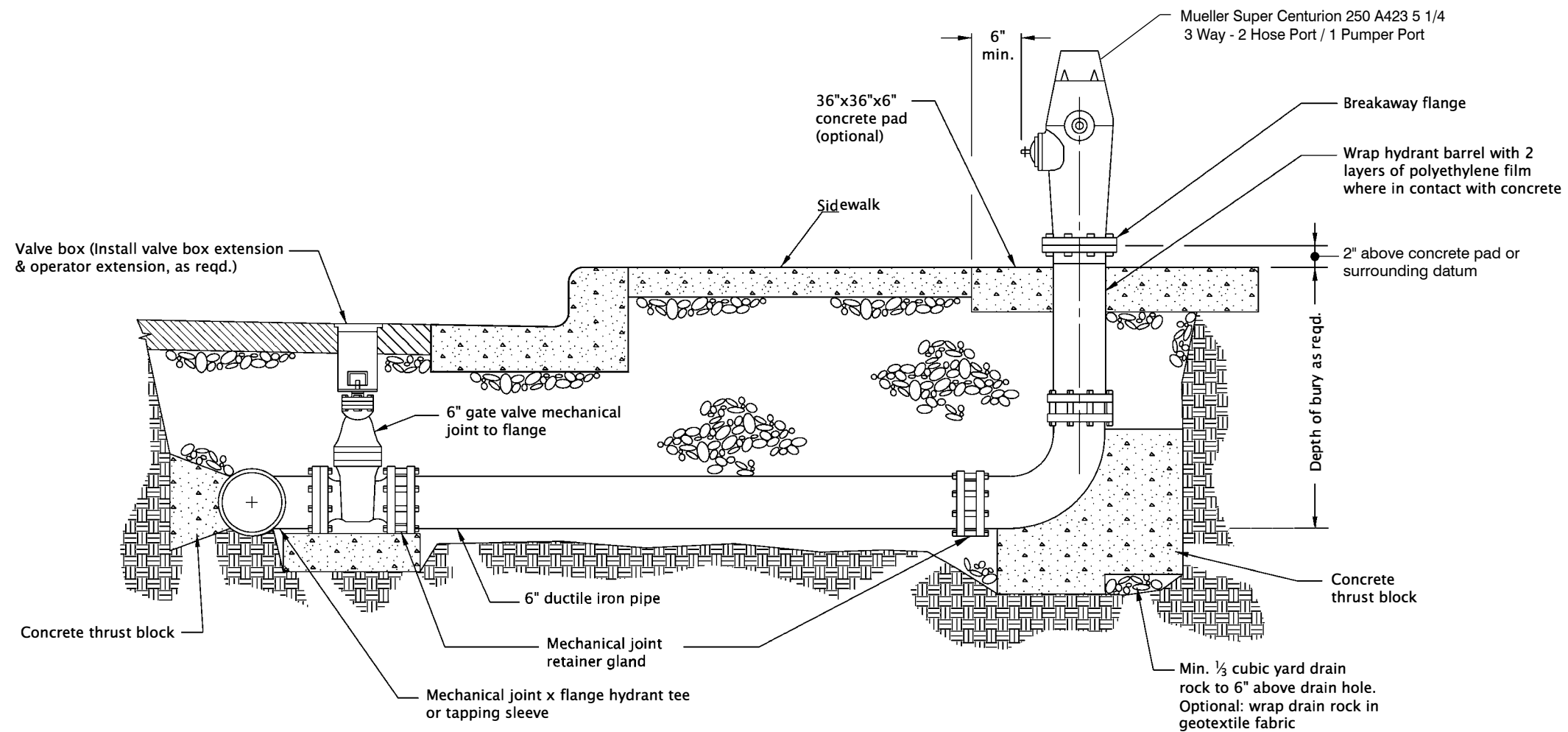
CITY OF THE DALLES STANDARD DRAWINGS

THRUST BLOCKING

2025

DATE	REVISION DESCRIPTION

rd254.dgn 20-JUL-2020



HYDRANT ASSEMBLY

GENERAL NOTES FOR ALL DETAILS ON THIS SHEET:

1. When pipe is shorter than 18', no joints allowed. Use mechanical joint retainer glands. Two 3/4" galvanized tie rods may be used in lieu of thrust blocks for installations less than 18' long. Coat tie rods with two coats of coal tar epoxy.
2. When pipe is longer than 18' retainer glands not required.
3. There shall be a minimum of 18" horizontal clearance around hydrant.
4. When placed adjacent to curb, hydrant port shall be 24" from face of curb.
5. Concrete thrust blocks shall be constructed as per thrust blocking Std. Dwg. RD250. Do not block drain holes.
6. Extensions required for hydrant systems shall be installed to the manufacturer's specifications.
7. Hydrants shall be placed to provide a minimum of 5' clearance from driveways, poles, and other obstructions.
8. Hydrant pumper port shall face direction of access.
9. Set hydrant plumb in all directions.
10. See project plans for details not shown.

CALC. BOOK NO. N/A

SDR DATE 25-JUL-2017

NOTE: All material and workmanship shall be in accordance with the current City of The Dalles Standard Specifications

CITY OF THE DALLES STANDARD DRAWINGS

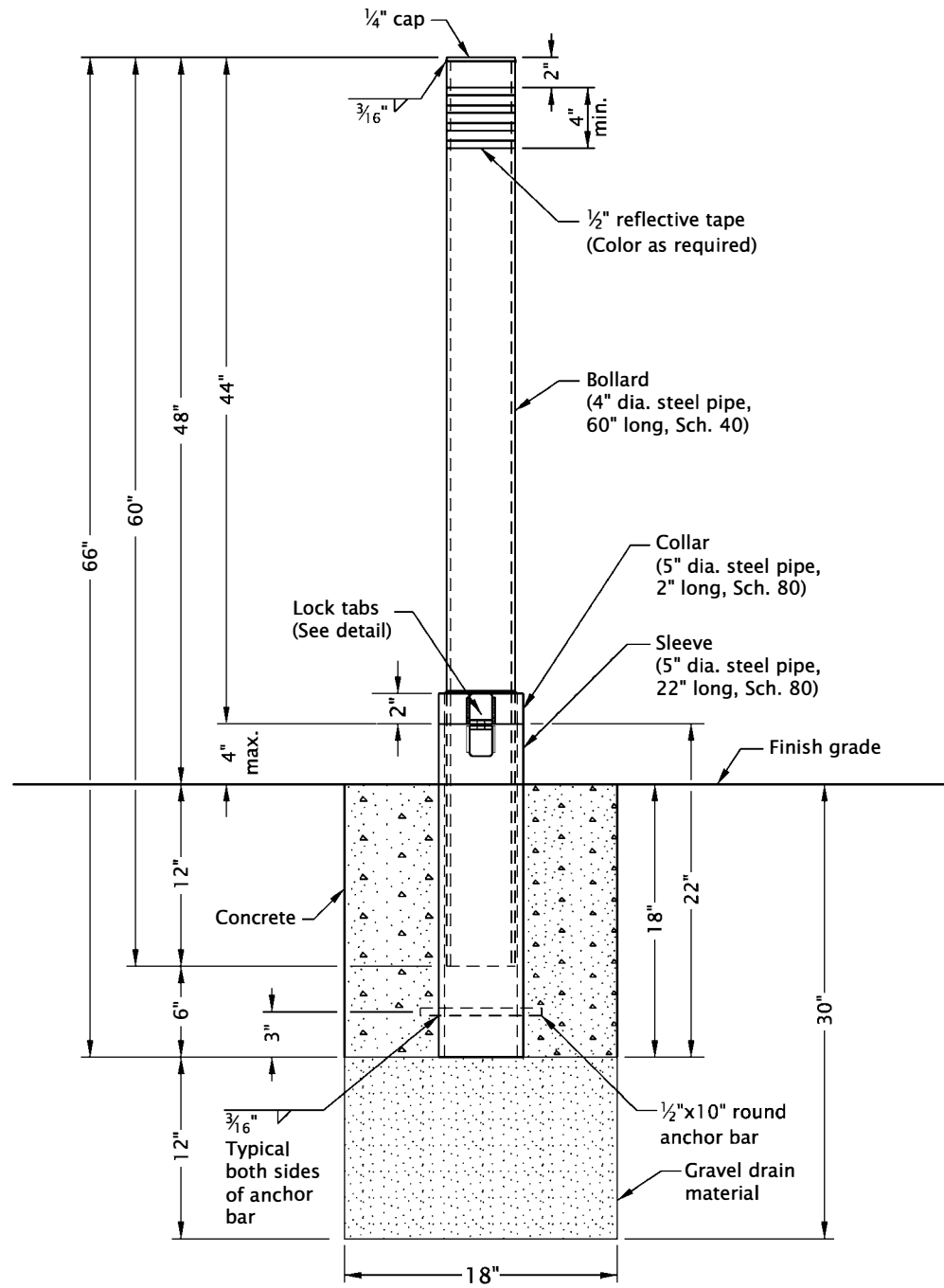
HYDRANT INSTALLATION

2025

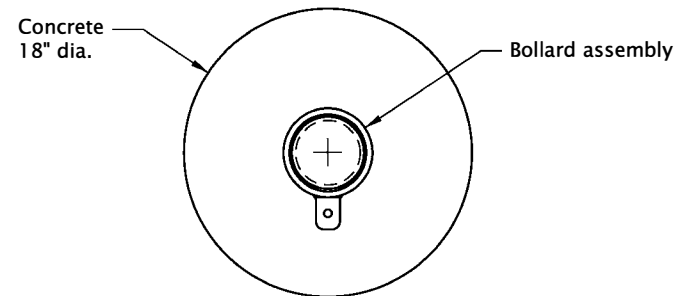
DATE	REVISION	DESCRIPTION

The selection and use of this Standard Drawing, while designed in accordance with generally accepted engineering principles and practices, is the sole responsibility of the user and should not be used without consulting a Registered Professional Engineer.

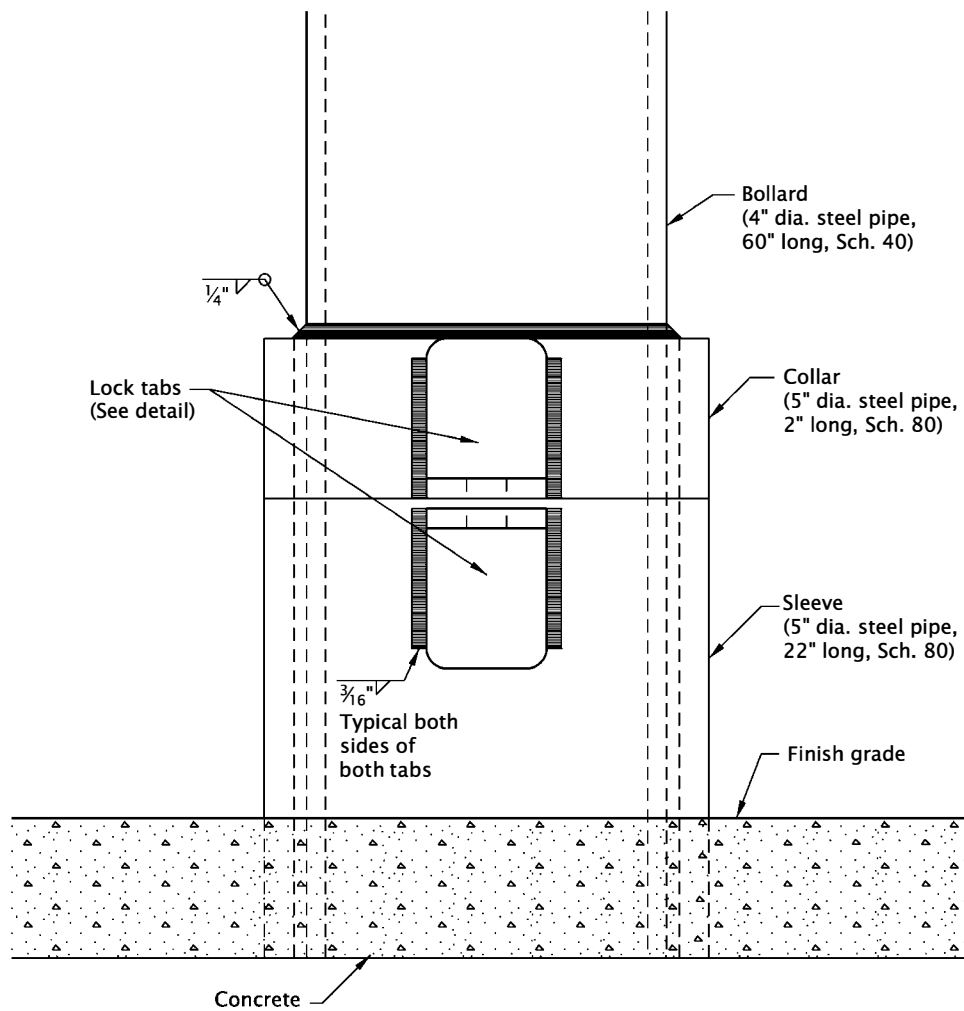
RD254



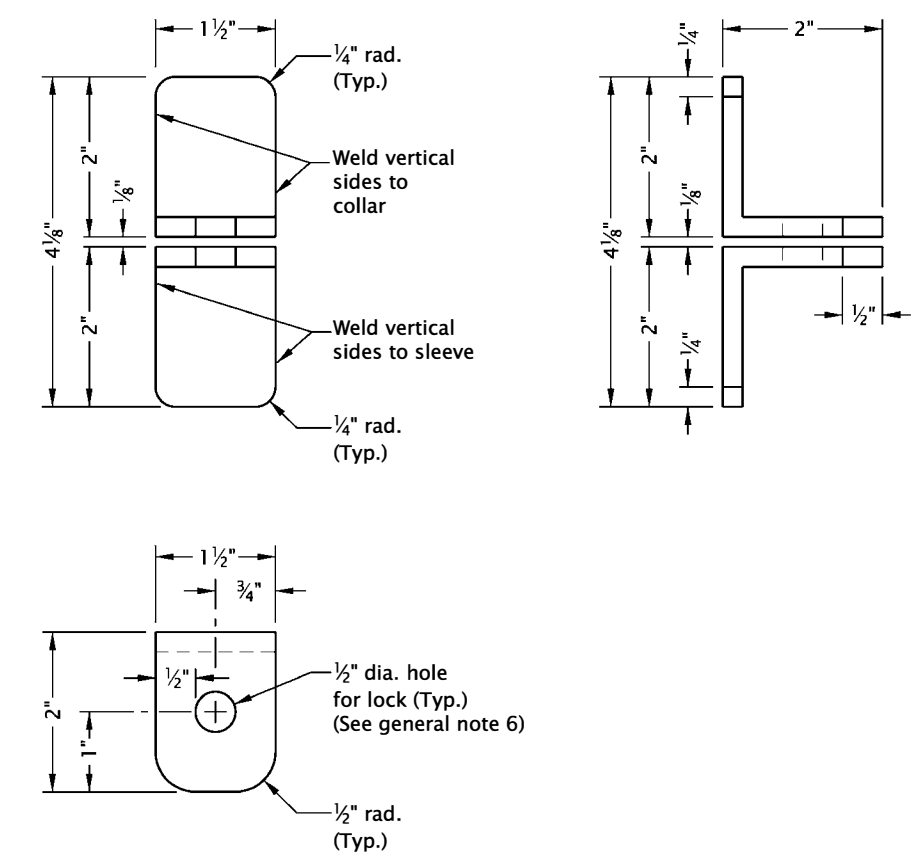
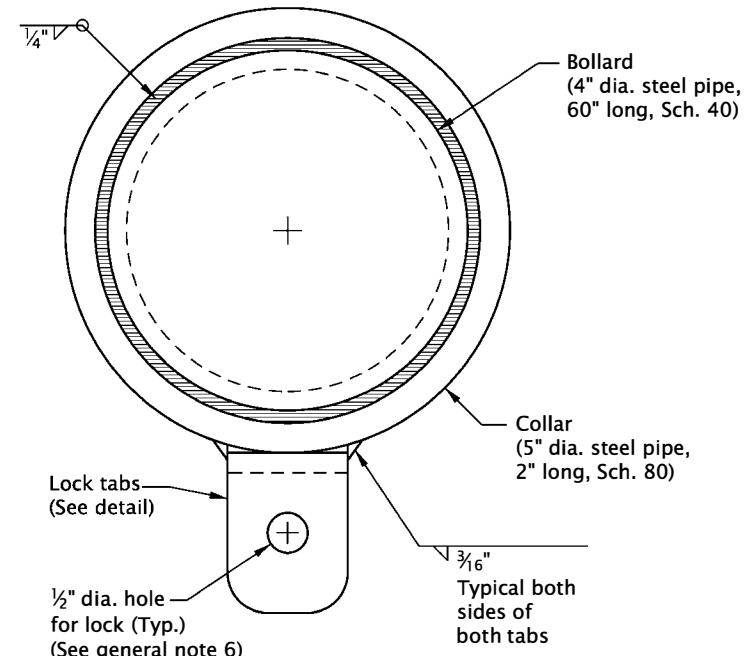
ELEVATION



PLAN



COLLAR & LOCK TABS



LOCK TABS
(2"x2"x1/4" steel angle)

GENERAL NOTES FOR ALL DETAILS ON THIS SHEET:

1. Grind all edges smooth.
2. Prime and paint bollard safety yellow after fabrication.
3. Hot-dip galvanize sleeve after fabrication.
4. All concrete shall be commercial grade concrete.
5. Orient lock assembly parallel with pedestrian traffic.
6. Provide lock, if required.
7. See project plans for details not shown.

CALC. BOOK NO. <u>N/A</u>	SDR DATE <u>25-JUL-2017</u>
---------------------------	-----------------------------

NOTE: All material and workmanship shall be in accordance with the current City of The Dalles Standard Specifications

CITY OF THE DALLES STANDARD DRAWINGS

HYDRANT BOLLARD

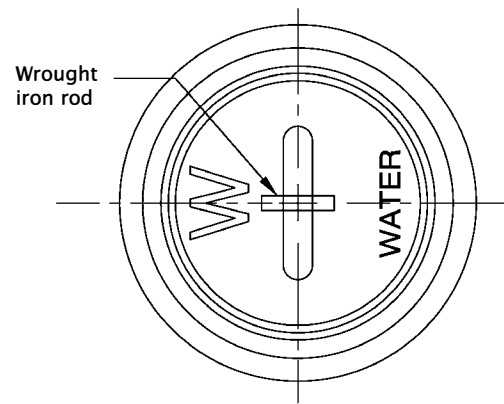
2025

DATE	REVISION DESCRIPTION

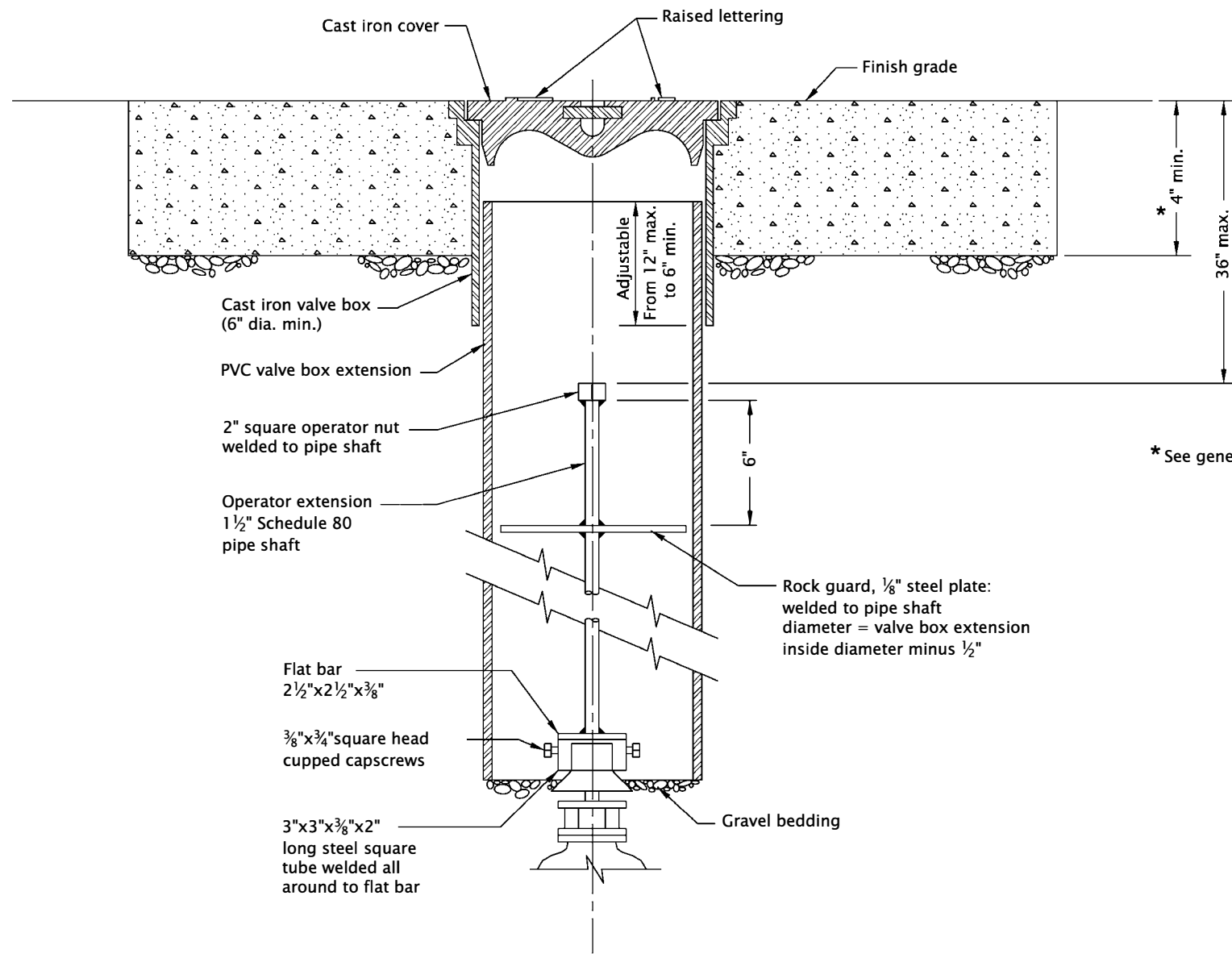
The selection and use of this Standard Drawing, while designed in accordance with generally accepted engineering principles and practices, is the sole responsibility of the user and should not be used without consulting a Registered Professional Engineer.

rd258.dgn 20-JUL-2020

RD258

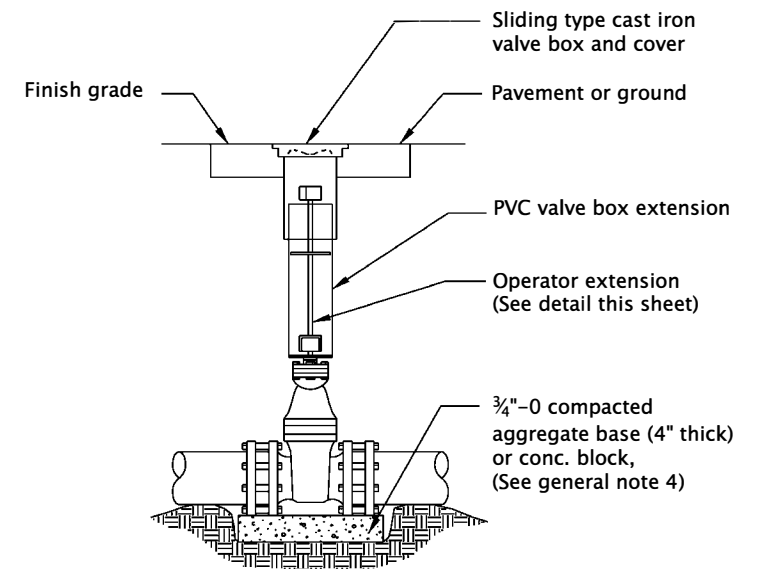


COVER PLAN



VALVE BOX EXTENSION SECTION

* See general note 8



VALVE BOX ASSEMBLY DETAIL

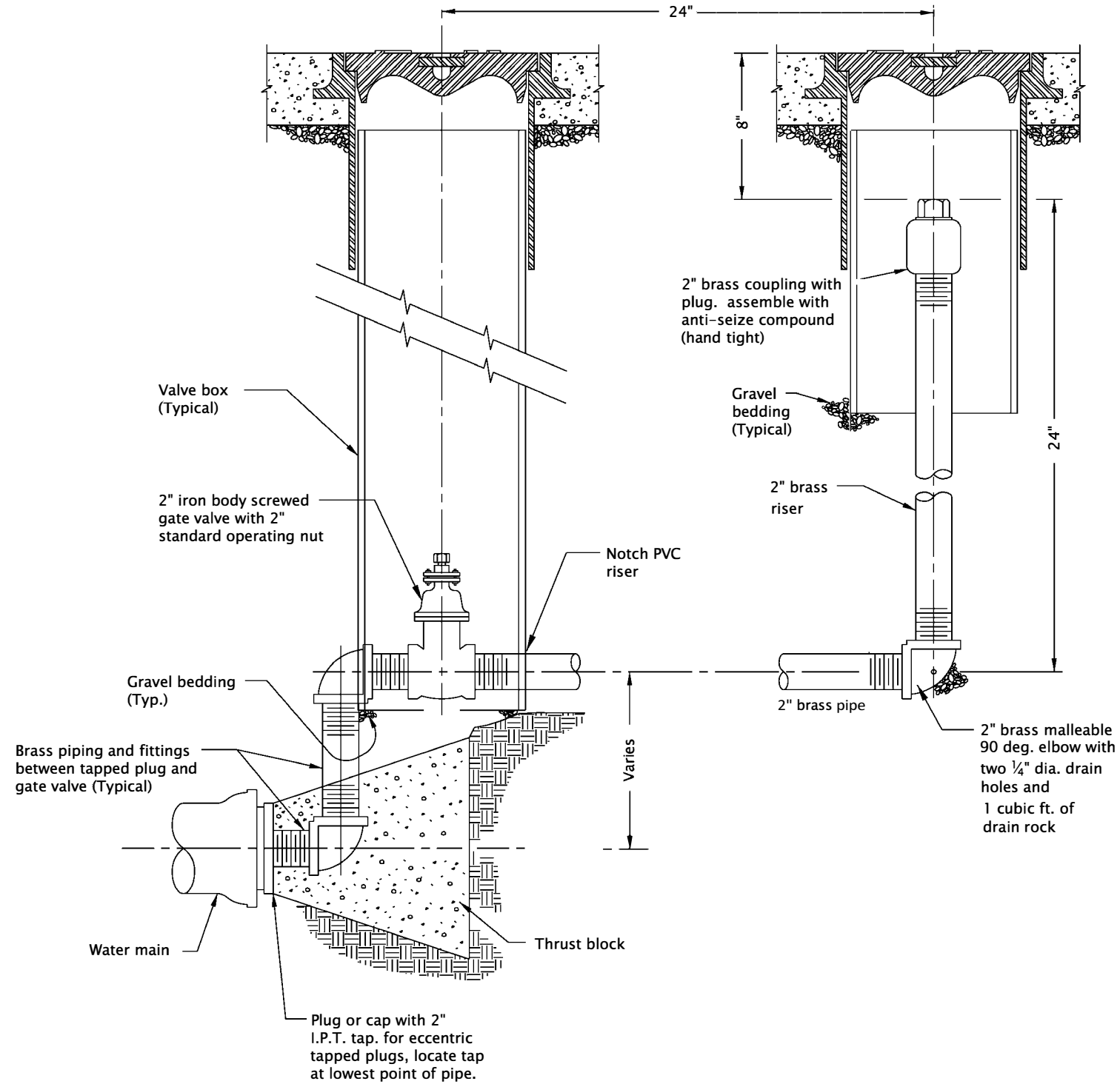
GENERAL NOTES FOR ALL DETAILS ON THIS SHEET:

1. Valve box not to rest on operating assembly.
2. Operator extension required when valve nut is deeper than 4' from finish grade.
3. Center valve box on axis of operator nut.
4. Valves 12" and smaller shall be provided with compacted aggr. base on undisturbed ground. Valves greater than 12" shall be installed on precast concrete block, (4" thick).
5. Welds shall be minimum 1/4" all around.
6. Hot dip galvanize operator extension after fabrication.
7. Casting shall meet H20 load requirement.
8. Provide concrete or asphalt pad (24" square, 4" thick), when required.
9. See project plans for details not shown.

CALC. BOOK NO. N/A SDR DATE 25-JUL-2017

NOTE: All material and workmanship shall be in accordance with the current City of The Dalles Standard Specifications

<p><i>The selection and use of this Standard Drawing, while designed in accordance with generally accepted engineering principles and practices, is the sole responsibility of the user and should not be used without consulting a Registered Professional Engineer.</i></p>		<p>CITY OF THE DALLES STANDARD DRAWINGS</p> <p>VALVE BOX AND OPERATOR EXTENSION ASSEMBLY</p>	
		<p>2025</p>	
DATE	REVISION	DESCRIPTION	



GENERAL NOTES FOR ALL DETAILS ON THIS SHEET:

1. Wrap main and fittings in thrust block zone with two layers of polyethylene film to facilitate future removal.
2. In lieu of concrete thrust block, restrain pipe or pour concrete straddle block.
3. See project plans for details not shown.

CALC. BOOK NO. N/A

SDR DATE 25-JUL-2017

NOTE: All material and workmanship shall be in accordance with the current City of The Dalles Standard Specifications

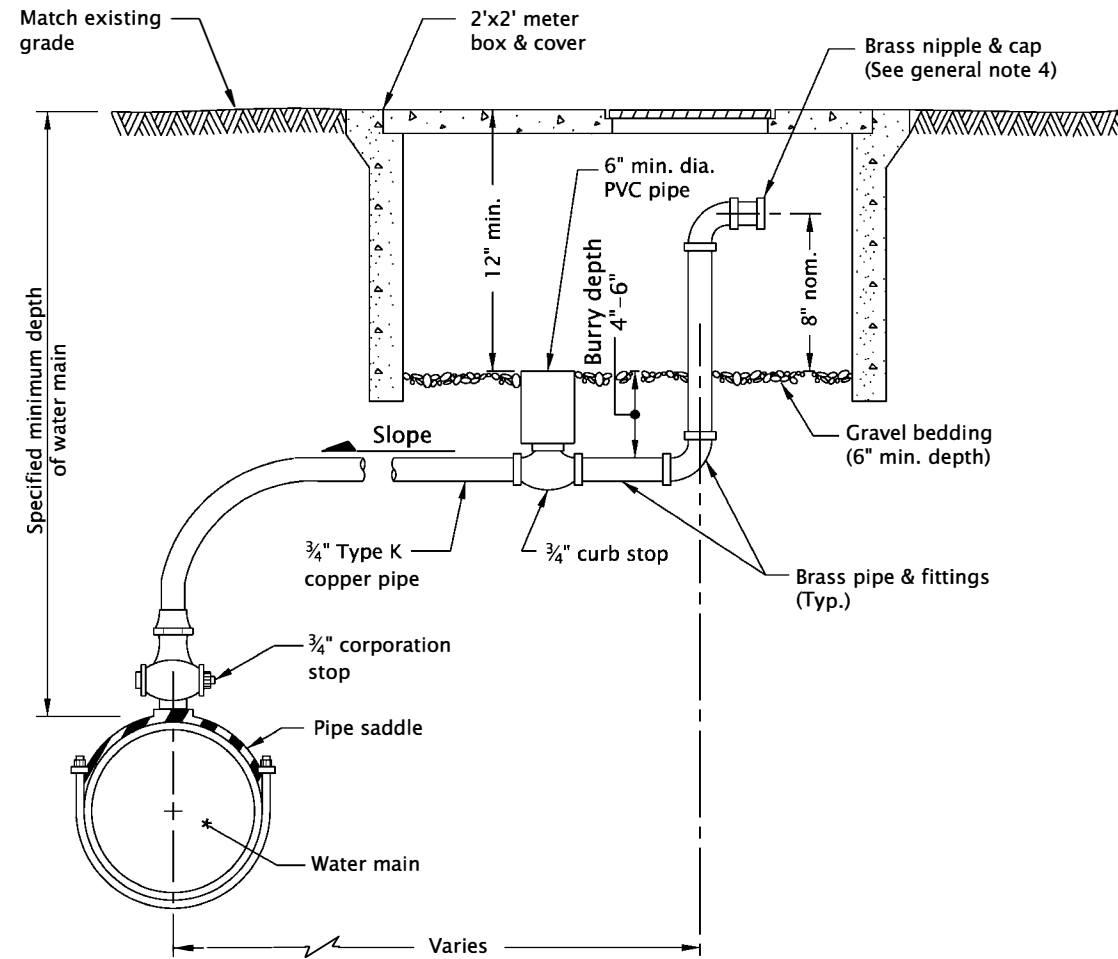
CITY OF THE DALLES STANDARD DRAWINGS

TYPICAL MAIN DEAD-END BLOWOFF ASSEMBLY

2025

DATE	REVISION	DESCRIPTION

The selection and use of this Standard Drawing, while designed in accordance with generally accepted engineering principles and practices, is the sole responsibility of the user and should not be used without consulting a Registered Professional Engineer.



GENERAL NOTES FOR ALL DETAILS ON THIS SHEET:

1. Locate at high point of main.
2. Tap top of main.
3. Provide insulation and additional depth when specified for freeze protection.
4. Provide minimum 6" side clearance.
5. See project plans for details not shown.

CALC. BOOK NO. N/A

SDR DATE 25-JUL-2017

NOTE: All material and workmanship shall be in accordance with the current City of The Dalles Standard Specifications

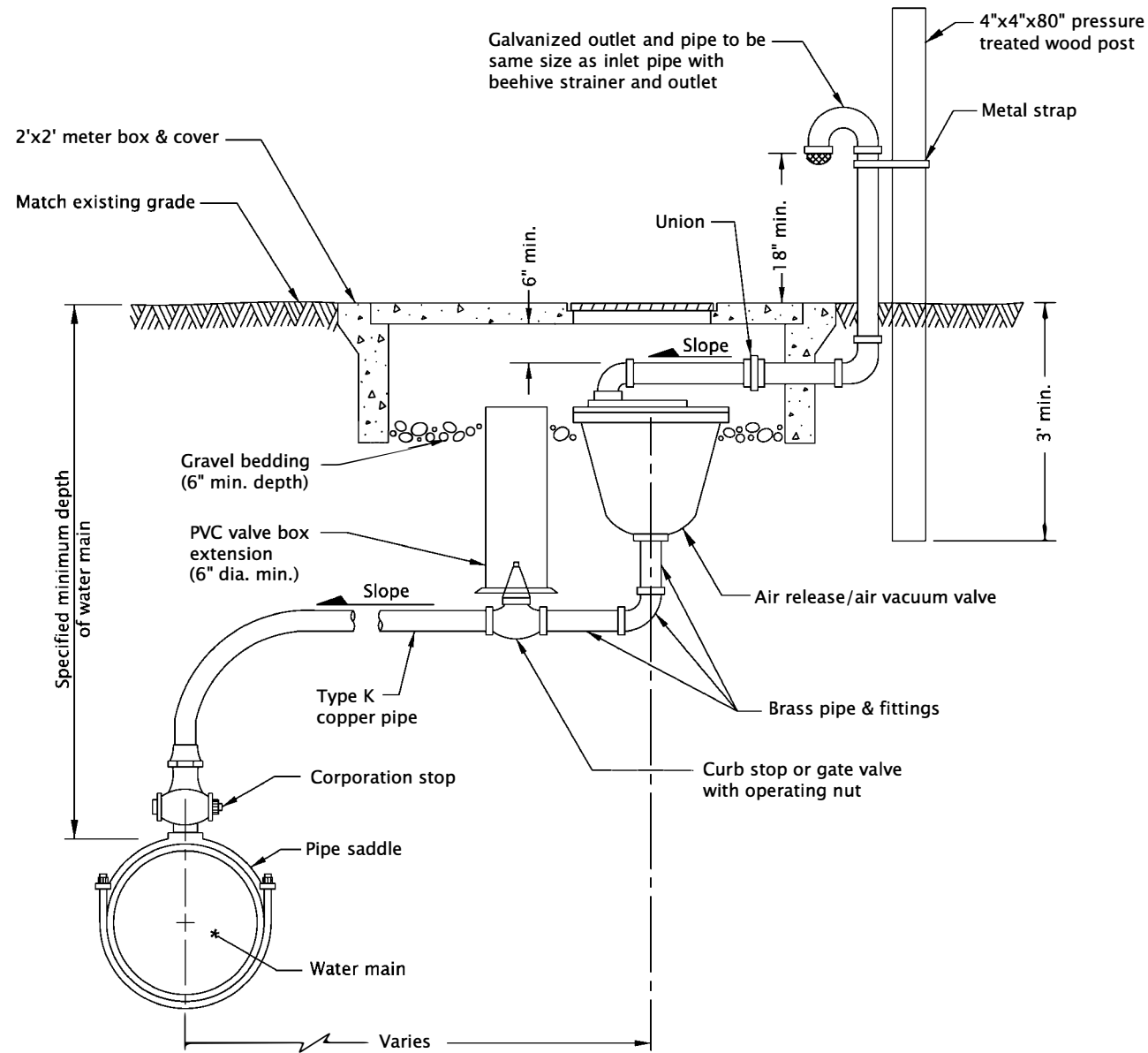
CITY OF THE DALLES STANDARD DRAWINGS

MANUAL AIR-RELEASE ASSEMBLY (3/4")

2025

DATE	REVISION	DESCRIPTION

The selection and use of this Standard Drawing, while designed in accordance with generally accepted engineering principles and practices, is the sole responsibility of the user and should not be used without consulting a Registered Professional Engineer.



GENERAL NOTES FOR ALL DETAILS ON THIS SHEET:

1. Air release/air vacuum valve shall be size specified in Contract. Piping and valves to be same size as combination air release/air vacuum valve.
2. Locate at high point of main.
3. Tap top of main.
4. Provide insulation and additional depth when specified for freeze protection.
5. See project plans for details not shown.

CALC. BOOK NO. N/A

SDR DATE 25-JUL-2017

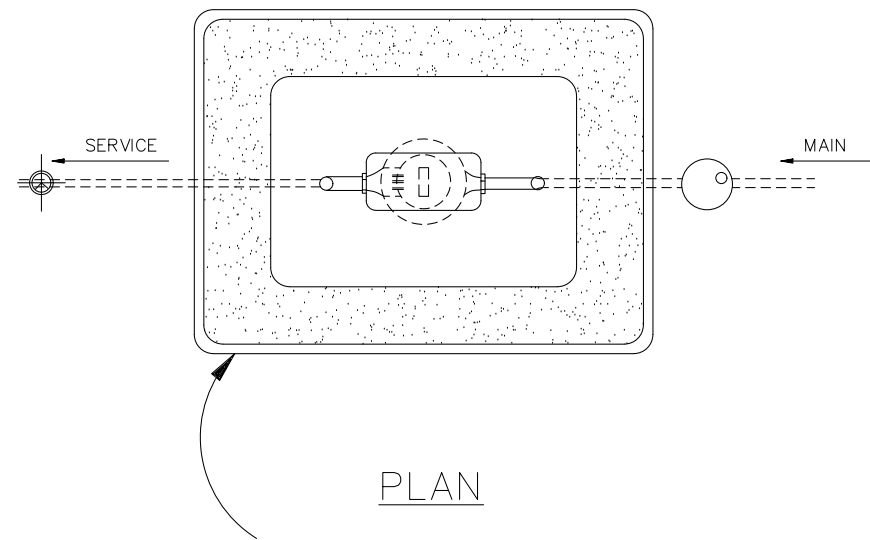
NOTE: All material and workmanship shall be in accordance with the current City of The Dalles Standard Specifications

**CITY OF THE DALLES STANDARD DRAWINGS
COMBINATION AIR RELEASE AIR
VACUUM VALVE ASSEMBLY (2"
AND SMALLER)**

2025

DATE	REVISION DESCRIPTION

The selection and use of this Standard Drawing, while designed in accordance with generally accepted engineering principles and practices, is the sole responsibility of the user and should not be used without consulting a Registered Professional Engineer.



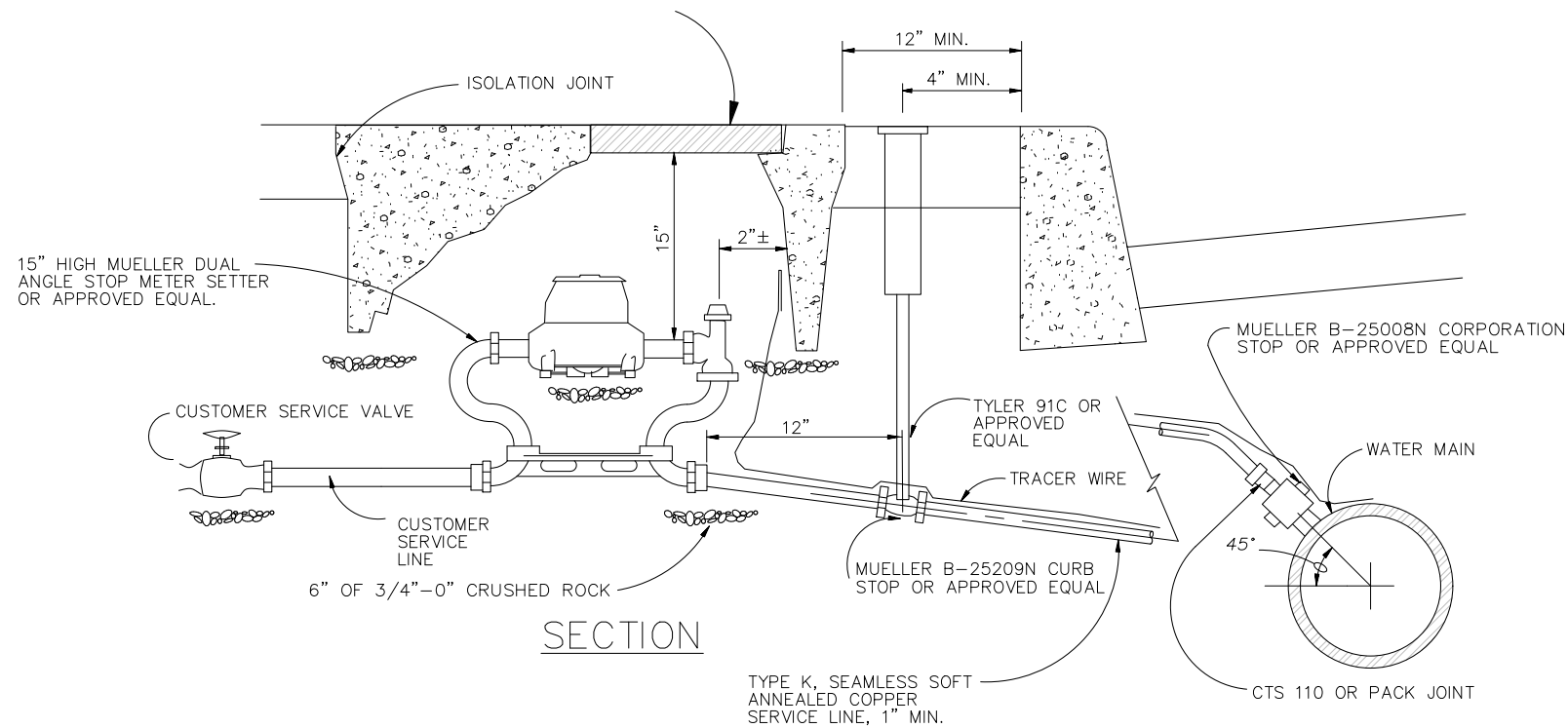
PLAN

1" AND SMALLER METERS:

12"x20"x24" AMORCAST METER BOX (P6000485X24 W/O MOUSEHOLES), AMORCAST COVER (A6000484DQ) WITH INSERT (SP-AA6000487 MAGNET 5X7 OPENING)

NOTES:

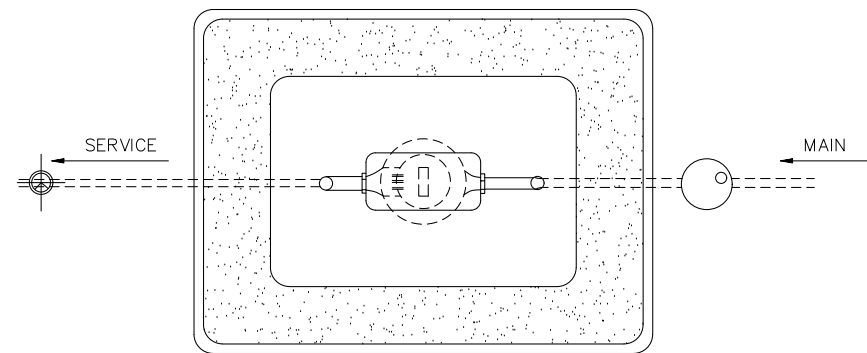
1. METER TO BE CENTERED AND SET PLUMB INSIDE METER BOX.
2. MANUFACTURED METER SETTER SHALL BE USED FOR 3/4" TO 1" SERVICES.
3. SET CURB STOP BOX 4" MINIMUM BEHIND CURB OR SIDEWALK.
4. METER BOXES SET IN DRIVEWAYS SHALL HAVE TRAFFIC RATED LIDS AND BOXES.
5. METER SHALL BE A BADGER M25 FOR 3/4" and BADGER M55 for 1".
6. METER SHALL BE EQUIPPED WITH ITRON 100W ERT AND BE WIRED WITH A MINIMUM OF 5 FEET OF CABLE INCLUDING ITRON INLINE CONNECTOR.
7. METERS SHALL COMPLY WITH "EPA'S LEAD REDUCTION ACT" (LEAD FREE)
8. METERS SHALL BE EQUIPPED WITH REGISTERS WITH A RESOLUTION THAT READS IN 1/10 OF A GALLON
9. SERVICE LINE AND FITTINGS SHALL BE 1" MIN. FROM MAIN TO SETTER, UNLESS OTHERWISE APPROVED.
10. SEE PROJECT PLANS FOR DETAILS NOT SHOWN.



SECTION

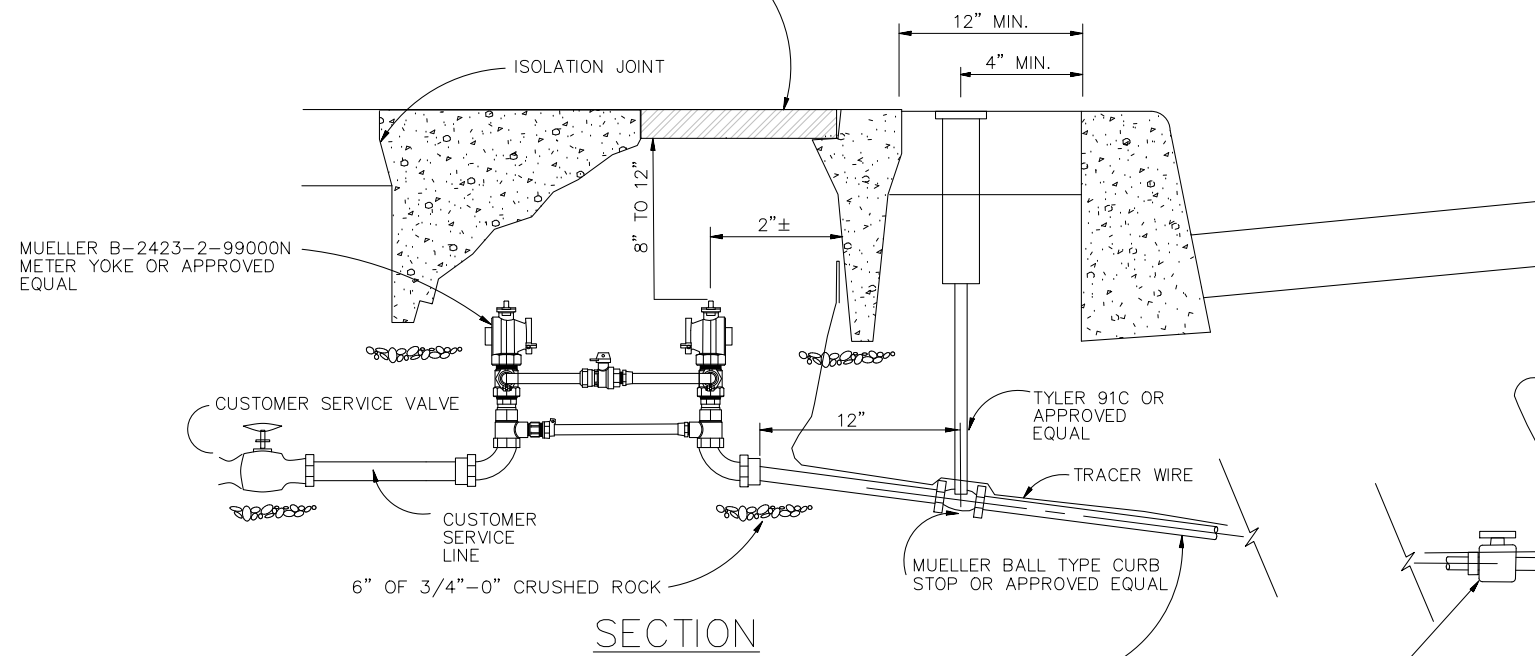
<p>The selection and use of this Standard Drawing, while designed in accordance with generally accepted engineering principles and practices, is the sole responsibility of the user and should not be used without consulting a Registered Professional Engineer.</p>		NOTE: All material and workmanship shall be in accordance with the current City of The Dalles Standard Specifications	
		CITY OF THE DALLES STANDARD DRAWING	
		3/4" - 1" WATER SERVICE CONNECTION	
		2025	
		REVISIONS	
DATE		DESCRIPTION	

RD274

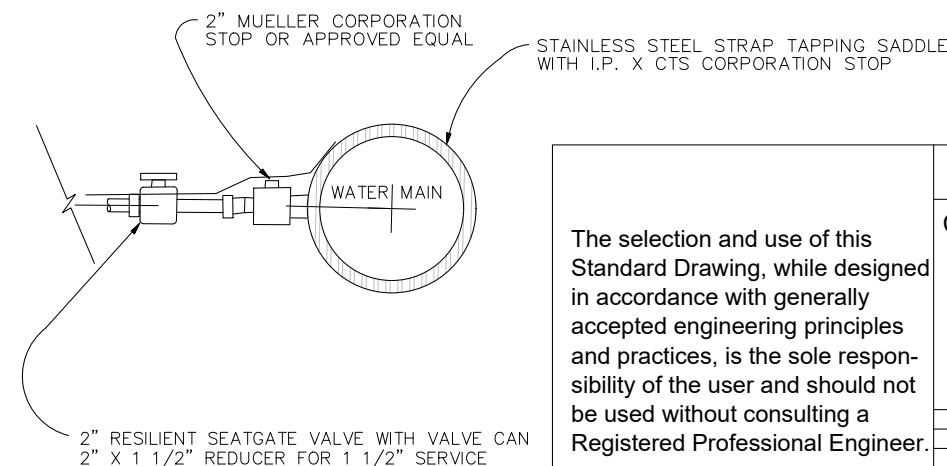


PLAN

17"X30"X22"AMORCAST METER BOX (P60001534X22 W/O MOUSEHOLES), AMORCAST COVER (A60001643DZ) WITH INSERT (SPA6000482 MAGNET 9X14 OPENING)



SECTION



NOTES:

1. METER TO BE CENTERED AND SET PLUMB INSIDE METER BOX.
2. SET CURB STOP BOX 4" MINIMUM BEHIND CURB OR SIDEWALK.
3. METER BOXES SET IN DRIVEWAYS SHALL HAVE TRAFFIC RATED LIDS.
4. METER SHALL BE BADGER M120 FOR 1 1/2", BADGER M170 FOR 2", AND GALLON READ.
5. METER SHALL BE EQUIPPED WITH ITRON 100W ERT AND BE WIRED WITH A MINIMUM OF 5 FEET OF CABLE INCLUDING ITRON INLINE CONNECTOR.
6. METERS SHALL COMPLY WITH "EPA'S LEAD REDUCTION ACT" (LEAD FREE)
7. METERS SHALL BE EQUIPPED WITH REGISTERS WITH A RESOLUTION THAT READS IN 1/10 OF A GALLON
8. SEE PROJECT PLANS FOR DETAILS NOT SHOWN

NOTE: All material and workmanship shall be in accordance with the current City of The Dalles Standard Specifications	
CITY OF THE DALLES STANDARD DRAWING	
1 1/2" - 2"	
WATER SERVICE CONNECTION	
2022	
REVISIONS	
DATE	DESCRIPTION

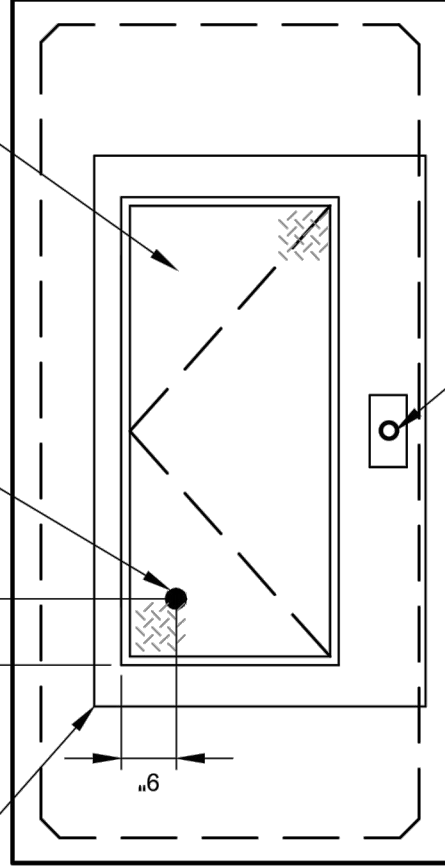
The selection and use of this Standard Drawing, while designed in accordance with generally accepted engineering principles and practices, is the sole responsibility of the user and should not be used without consulting a Registered Professional Engineer.

RD275

3'-0" X 5'-0" ALUMINUM,
SINGLE LEAF CHANNEL
FRAME DOOR. DRAIN TO
SUMP WITH 1-1/2" PIPE

RADIO ERT

10-1/2"



COVER SLAB

6

DAVIT ARM BASE

PLAN VIEW WITH COVER SLAB

NTS

DI SLEEVE
(RJ X RJ)
RESTRAIN
BETWEEN TEE
IN VAULT TO
TEE, BEND
OR BLDG

DI SLEEVE (RJ X RJ)
RESTRAIN BETWEEN
TEE IN VAULT TO
TEE, BEND OR CONC
BLOCKING

1'-0"
MIN

LOCKABLE SHUT-
OFF VALVE

1'-0"
MIN

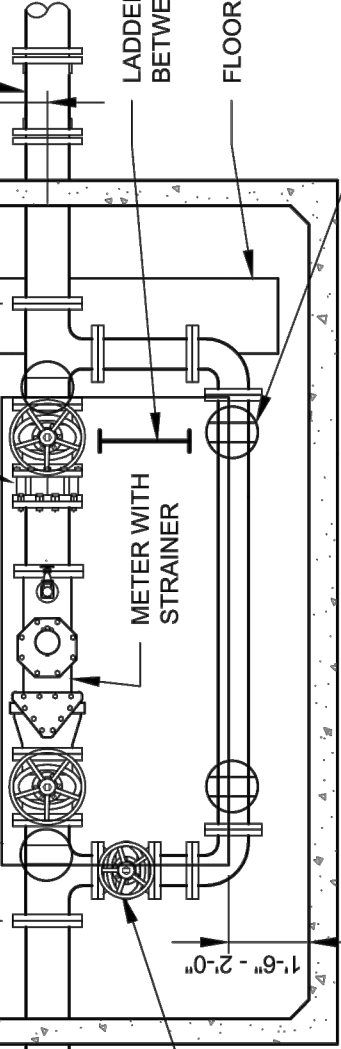
FCA

DOOR FRAME

1'-0"
MIN

1'-6" - 2'-0"

FLOW



LADDER, CENTER
BETWEEN PIPING

FLOOR DRAIN

PIPE SUPPORT
LOCATION, TYP

NOTE:

6" DETAIL SHOWN

PLAN VIEW OF EQUIPMENT

NTS

VAULT, FITTINGS AND PIPING SIZING REQUIREMENTS			MIN INSIDE VAULT DIM			UTILITY VAULT NO. *
METER SIZE	BYPASS VALVES AND PIPING	BYPASS TEE (FL X FL)	LEN	WIDTH	HT	
3"	3"	3" X 3"	10 FT	6 FT	6 FT	810 - LA
4"	4"	4" X 4"	10 FT	6 FT	6 FT	810 - LA
6"	4"	6" X 4"	12 FT	6 FT	6 FT	810 - LA

* OR APPROVED EQUAL

NOTES:

1. VAULT ACCESS HATCH SHALL BE DRILLED FOR INSTALLATION OF RADIO ERT.
2. METER SHALL BE OBTAINED BY THE CONTRACTOR FROM THE SUPPLIER AND DELIVERED TO CITY MAINTENANCE OPERATIONS CENTER FOR STORAGE UNTIL INSTALLATION. WHEN METER APPLICATION IS APPROVED FOR INSTALLATION, INCLUDING PAYMENT OF CONNECTION FEES, THE CONTRACTOR SHALL RETRIEVE AND INSTALL METER.
3. A GRAVITY VAULT DRAIN (DI) SHALL BE CONNECTED TO STORM SYSTEM AS SHOWN ON THE DRAWINGS.
4. PAINT ALL EXPOSED PIPING AND FITTINGS INSIDE VAULT, EXCEPT METER BODY.
5. CENTER PIPING UNDER HATCH OPENING.
6. METER BOXES SET IN DRIVEWAYS SHALL HAVE TRAFFIC RATED LIDS.
7. METER SHALL BE A TYPE AND MAKE ACCEPTABLE TO THE CITY.
8. METER SHALL BE EQUIPPED WITH REGISTERS THAT ARE COMPATIBLE WITH THE "ITRON MOBILE COLLECTION SYSTEM" AND BE WIRED WITH A MINIMUM OF 5 FEET OF CABLE INCLUDING ITRON INLINE CONNECTOR.
9. METERS SHALL COMPLY WITH "EPA'S LEAD REDUCTION ACT" (LEAD FREE)
10. METER SHALL BE EQUIPPED WITH REGISTERS WITH A RESOLUTION THAT READS IN 1/10 OF A GALLON.

NOTE: All material and workmanship shall be in accordance with the current City of The Dalles Standard Specifications

CITY OF THE DALLES STANDARD DRAWING

**WATER METER PLAN VIEW
3", 4" & 6" METER DETAILS**

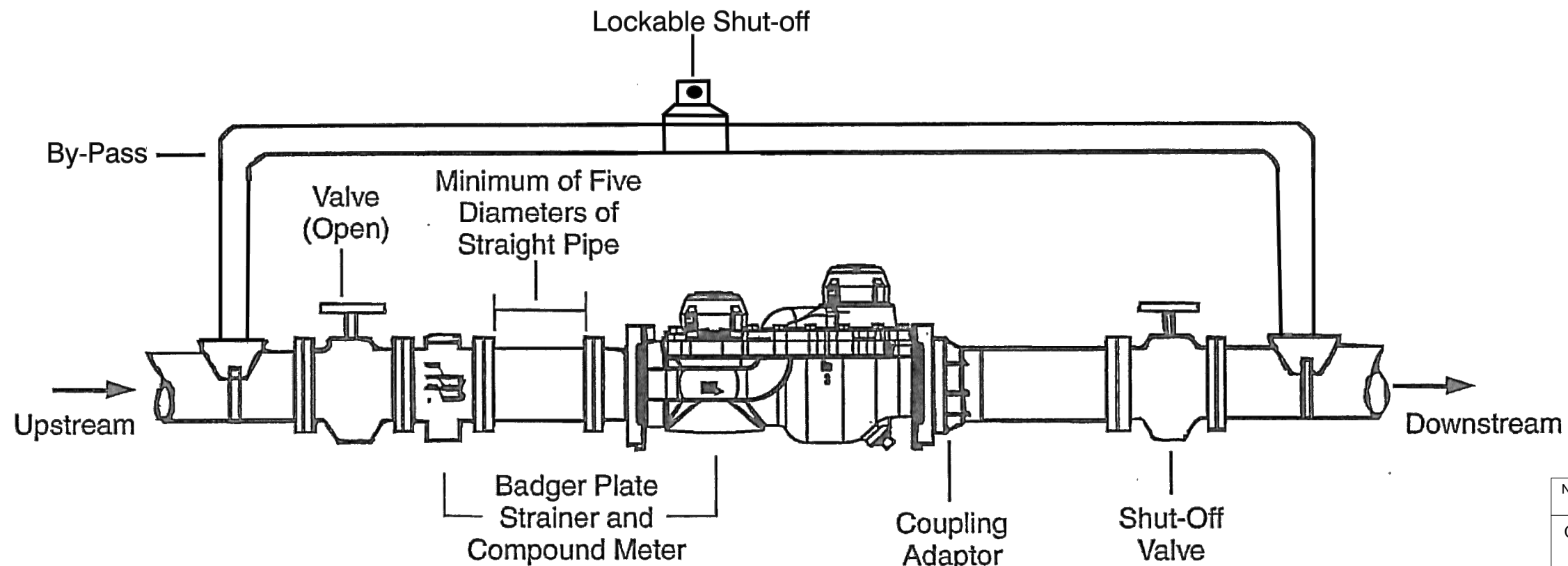
2025

REVISIONS	
DATE	DESCRIPTION

The selection and use of this Standard Drawing, while designed in accordance with generally accepted engineering principles and practices, is the sole responsibility of the user and should not be used without consulting a Registered Professional Engineer.

NOTES:

1. METER TO BE CENTERED AND SET PLUMB INSIDE METER BOX.
2. METER BOXES SET IN DRIVEWAYS SHALL HAVE TRAFFIC RATED LIDS.
3. METER SHALL BE A TYPE AND MAKE ACCEPTABLE TO THE CITY AND GALLON READ.
4. METER SHALL BE EQUIPPED WITH REGISTERS THAT ARE COMPATIBLE WITH THE "ITRON MOBILE COLLECTION SYSTEM" AND BE WIRED WITH A MINIMUM OF 5 FEET OF CABLE INCLUDING ITRON INLINE CONNECTOR.
5. METERS SHALL COMPLY WITH "EPA'S LEAD REDUCTION ACT" (LEAD FREE)
6. METERS SHALL BE EQUIPPED WITH REGISTERS WITH A RESOLUTION THAT READS IN 1/10 OF A GALLON
7. BYPASS SHALL BE IN SAME VAULT AS METER.



The selection and use of this Standard Drawing, while designed in accordance with generally accepted engineering principles and practices, is the sole responsibility of the user and should not be used without consulting a Registered Professional Engineer.

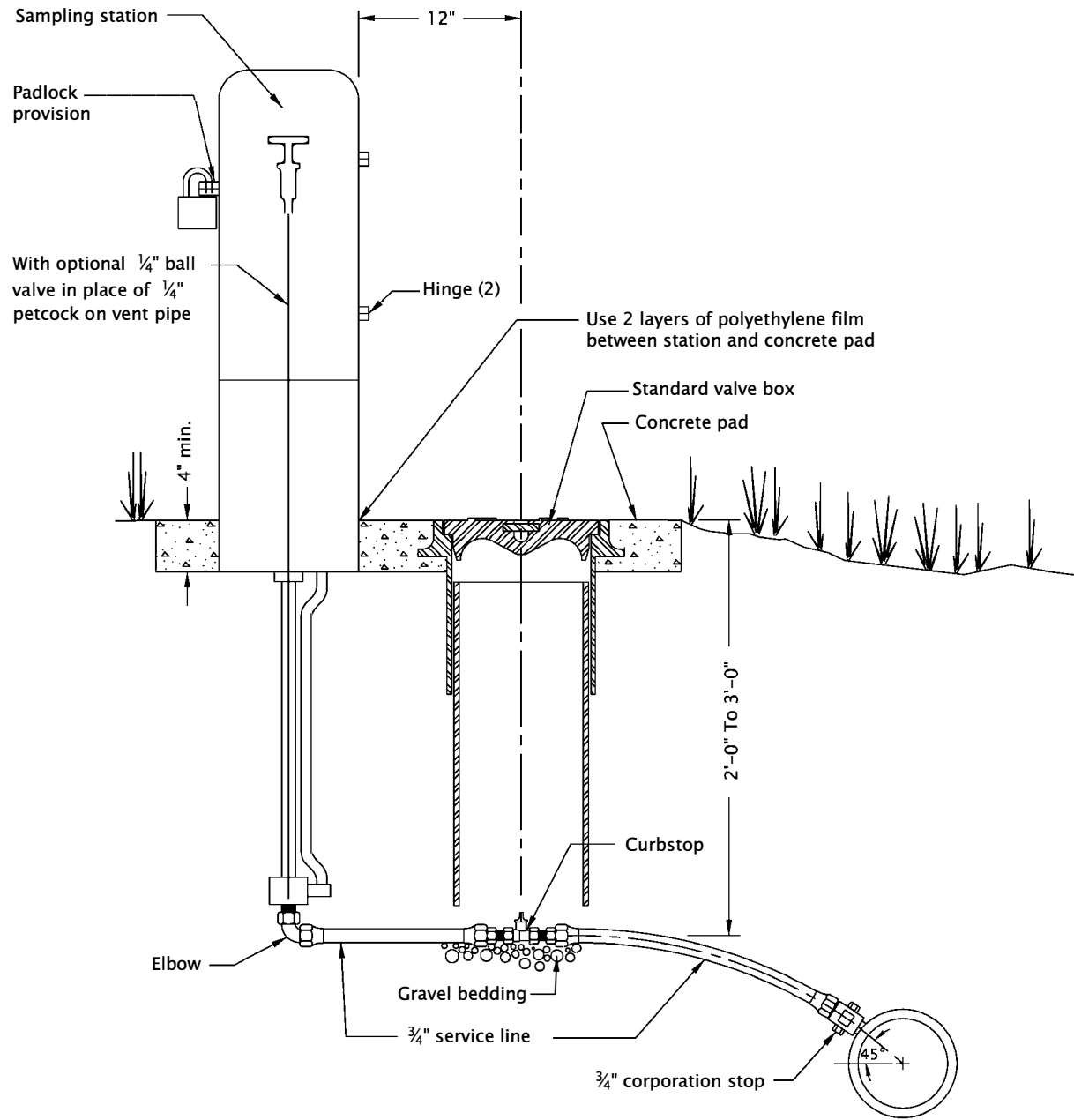
NOTE: All material and workmanship shall be in accordance with the current City of The Dalles Standard Specifications

CITY OF THE DALLES STANDARD DRAWING

COMPOUND WATER METER

2025

REVISIONS	
DATE	DESCRIPTION



GENERAL NOTES FOR ALL DETAILS ON THIS SHEET:

1. Provide insulation and additional depth when specified for freeze protection.
2. Sampling Station shall be a Kupferle Eclipse #88—SS or approved equal.
2. See project plans for details not shown.

CALC. BOOK NO. N/A

SDR DATE 25-JUL-2017

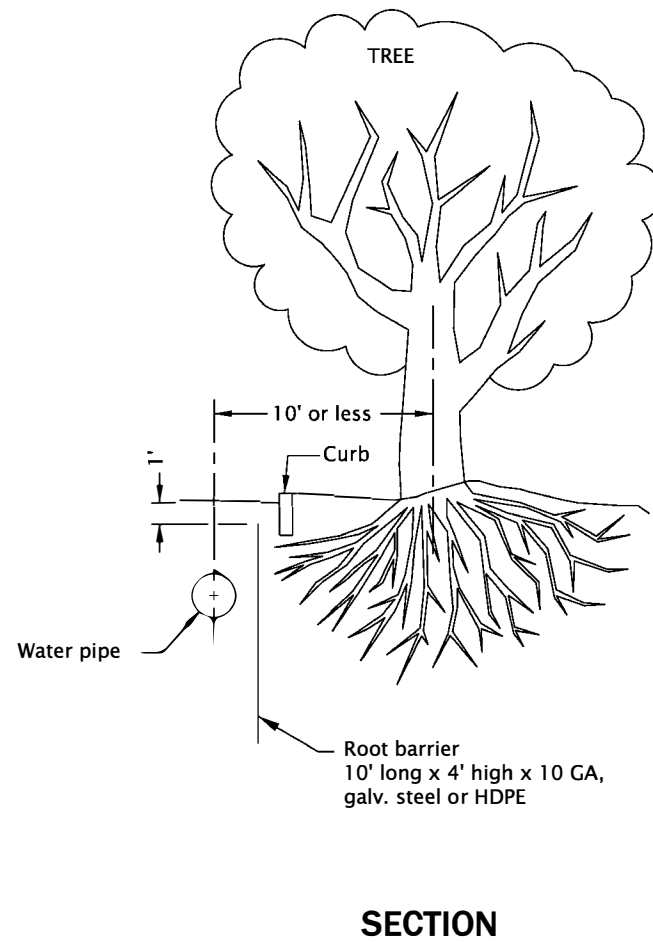
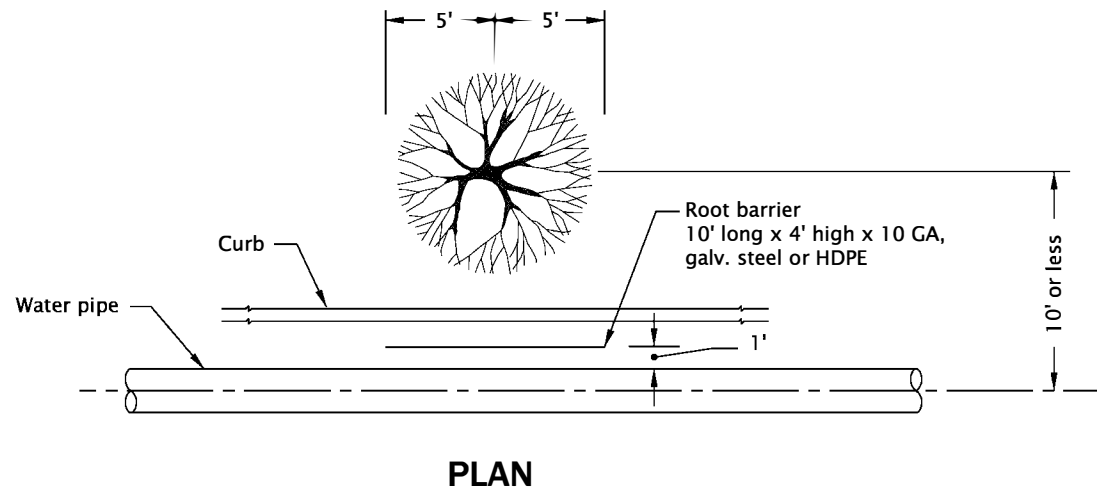
The selection and use of this Standard Drawing, while designed in accordance with generally accepted engineering principles and practices, is the sole responsibility of the user and should not be used without consulting a Registered Professional Engineer.

NOTE: All material and workmanship shall be in accordance with the current City of The Dalles Standard Specifications

CITY OF THE DALLES STANDARD DRAWINGS

WATER SAMPLING STATION

DATE	REVISION	DESCRIPTION
	2025	



GENERAL NOTES FOR ALL DETAILS ON THIS SHEET:

1. Where existing parkway trees have been root pruned, install continuous, lineal root barrier adjacent to the pipe.
2. Root sealer shall be applied to all cut root areas which are larger than 2" in diameter. The sealer shall be applied as soon as practical after the cuts have been made. Root sealer shall be approved by the engineer at least 48 hours in advance of the pruning operation.
3. Root barriers shall be fabricated from a high density, high impact plastic or hot dipped galvanized steel.
4. See project plans for details not shown.

CALC. BOOK NO. N/A

SDR DATE 25-JUL-2017

NOTE: All material and workmanship shall be in accordance with the current City of The Dalles Standard Specifications

CITY OF THE DALLES STANDARD DRAWINGS

ROOT BARRIER

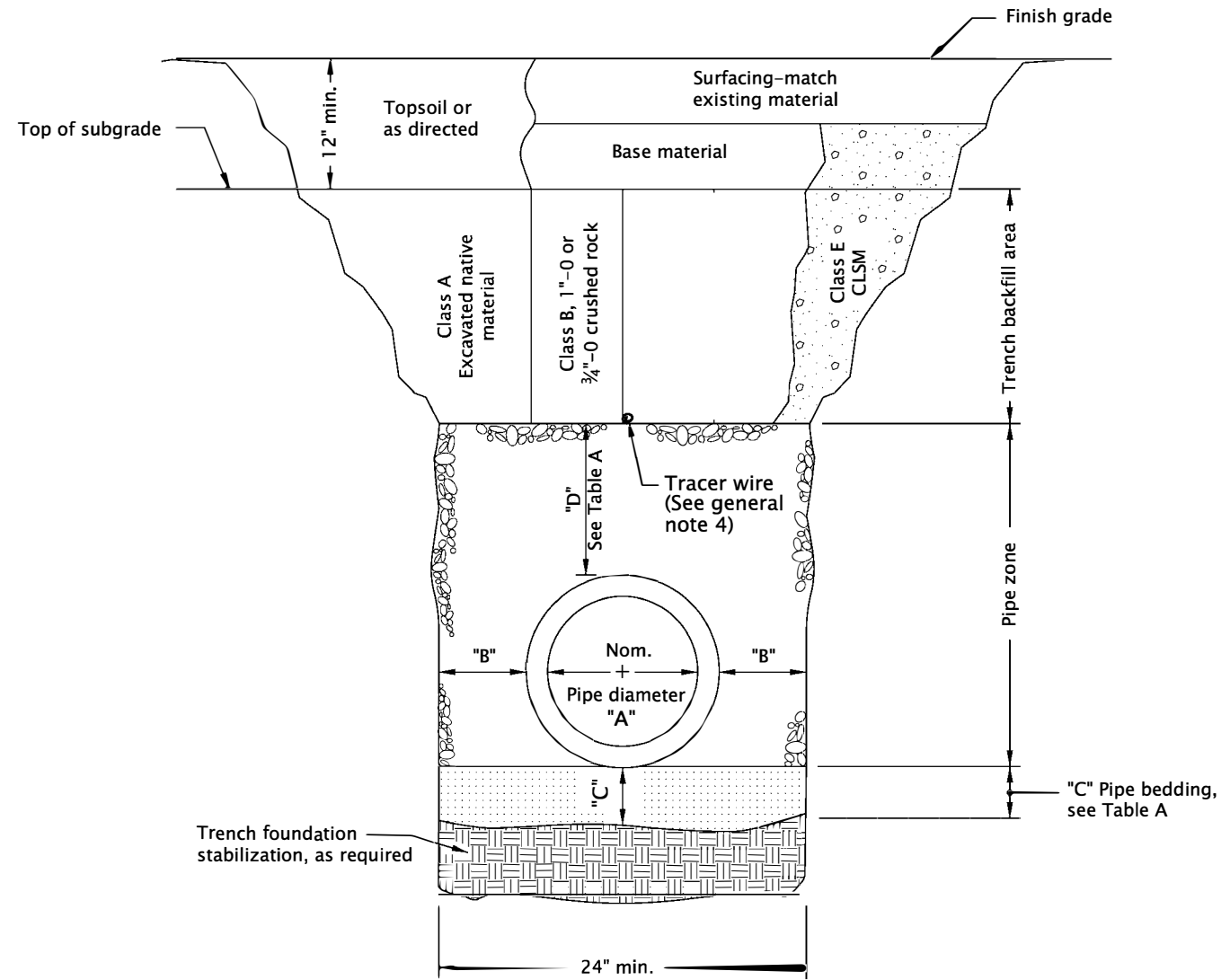
The selection and use of this Standard Drawing, while designed in accordance with generally accepted engineering principles and practices, is the sole responsibility of the user and should not be used without consulting a Registered Professional Engineer.

DATE	REVISION	DESCRIPTION

TABLE A

"A" (in)	"B" (in)	"C" (in)	"D" (in)
4	10	4	8
6	10	4	8
8	10	6	10
10	10	6	10
12	12	6	10
15	12	6	10
18	16	6	12
21	16	6	12
24	18	6	12
30	18	6	12
36	24	6	14
42	24	6	14
48	24	6	14
54	24	6	14
60	24	6	14
66	24	6	14
72	24	6	14

For pipes over 72" diameter, see general note 3.



MULTIPLE INSTALLATIONS	
DIAMETER	MIN. SPACE BETWEEN PIPES
Up to 48"	24"
48" to 72"	One half (1/2) dia. of pipe

GENERAL NOTES FOR ALL DETAILS ON THIS SHEET:

1. Surfacing of paved areas shall comply with street cut Std. Dwg. RD302.
2. For pipe installation in embankment areas where the trench method will not be used and the pipe is ≥ 36 " diameter, increase dimension "B" to nominal pipe diameter.
3. Pipes over 72" diameter are structures, and are not applicable to this drawing.
4. See Std. Dwg. RD336 for tracer wire details (When required).

CALC. BOOK NO. N/A

SDR DATE 14-JUL-2014

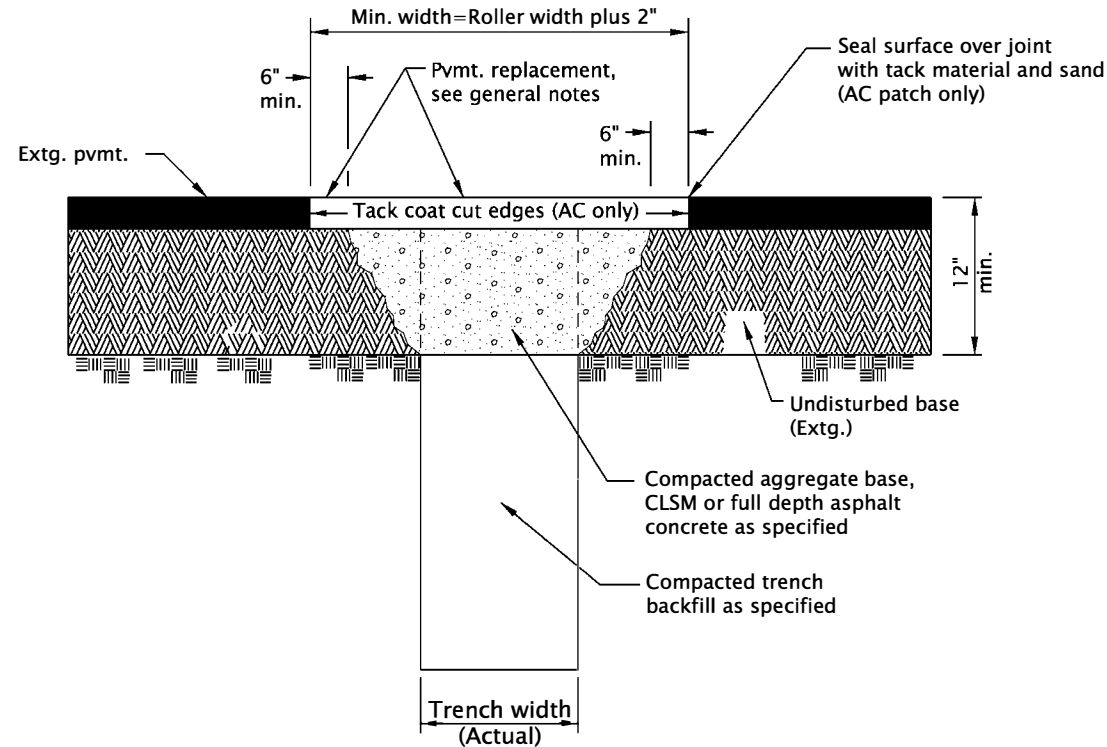
NOTE: All material and workmanship shall be in accordance with the current City of The Dalles Standard Specifications

**CITY OF THE DALLES STANDARD DRAWINGS
TRENCH BACKFILL, BEDDING, PIPE
ZONE AND MULTIPLE
INSTALLATIONS**

2025

DATE	REVISION	DESCRIPTION

The selection and use of this Standard Drawing, while designed in accordance with generally accepted engineering principles and practices, is the sole responsibility of the user and should not be used without consulting a Registered Professional Engineer.



- GENERAL NOTES FOR ALL DETAILS ON THIS SHEET:
1. All existing AC or PCC pavement shall be sawcut prior to repaving.
 2. Concrete pavement shall be replaced with concrete to a minimum thickness of 8" or to the thickness of removed pavement, whichever is greater.
 3. For joining new concrete to existing concrete, see contract plans for sepecific details.
 4. Place AC mix minimum thkn. of 6" or the thkn. of the removed pavement, whichever is greater. Compact as specified.

CALC. BOOK NO. N/A SDR DATE 20-JUL-2020

NOTE: All material and workmanship shall be in accordance with the current City of The Dalles Standard Specifications

CITY OF THE DALLES STANDARD DRAWINGS

STREET CUT

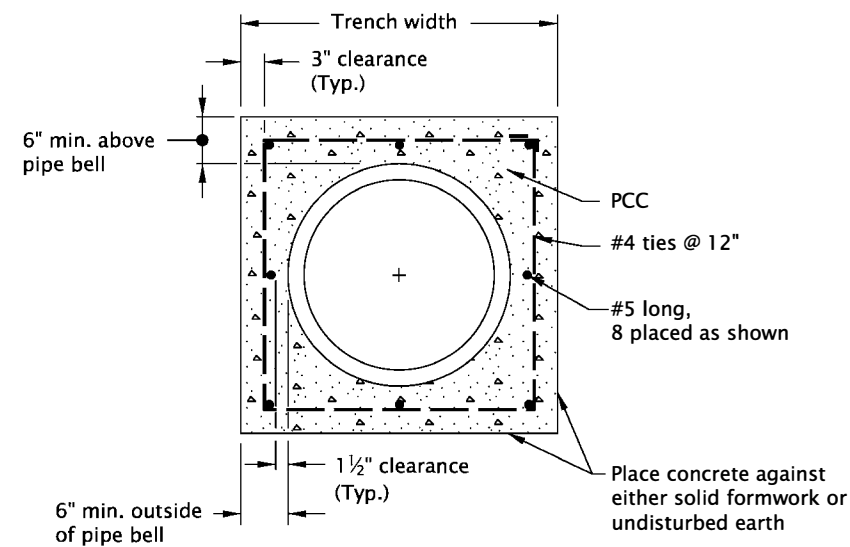
2025

DATE	REVISION	DESCRIPTION

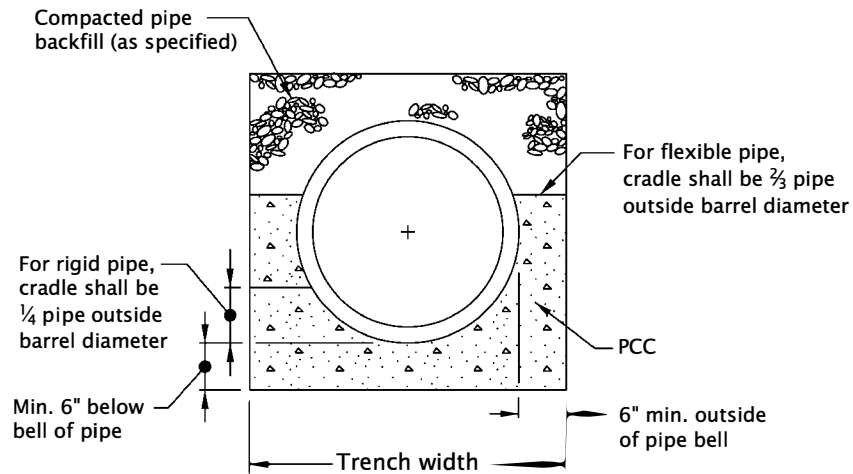
The selection and use of this Standard Drawing, while designed in accordance with generally accepted engineering principles and practices, is the sole responsibility of the user and should not be used without consulting a Registered Professional Engineer.

rd306.dgn 20-JUL-2020

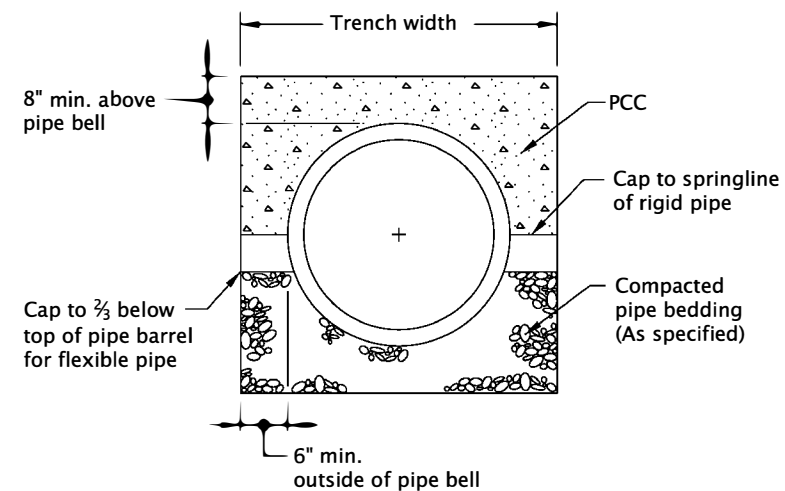
RD306



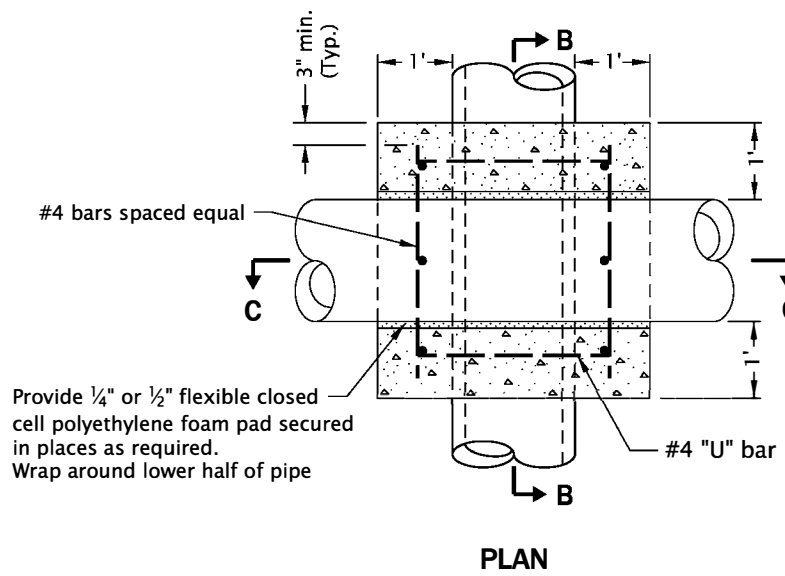
CONCRETE ENCASEMENT DETAIL



CRADLE DETAIL

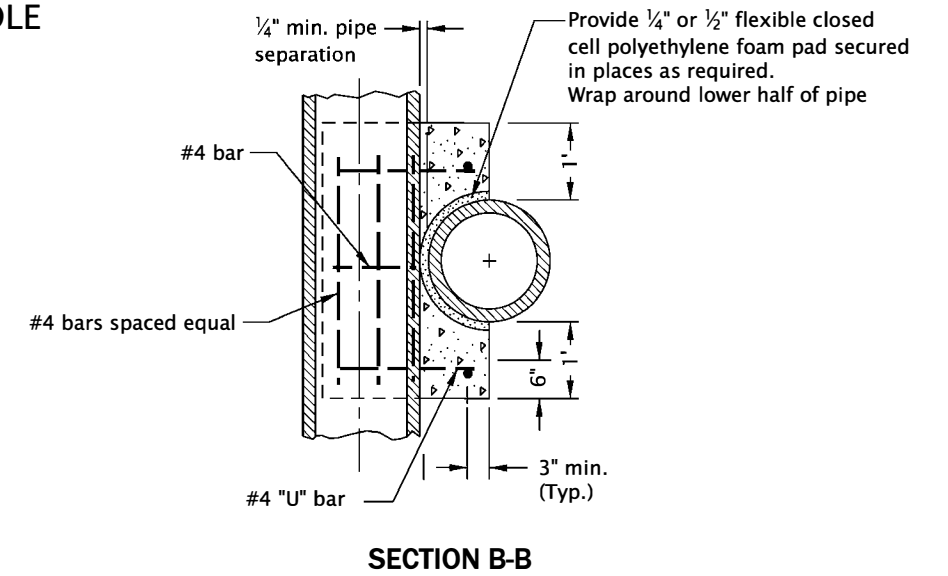


CAP DETAIL

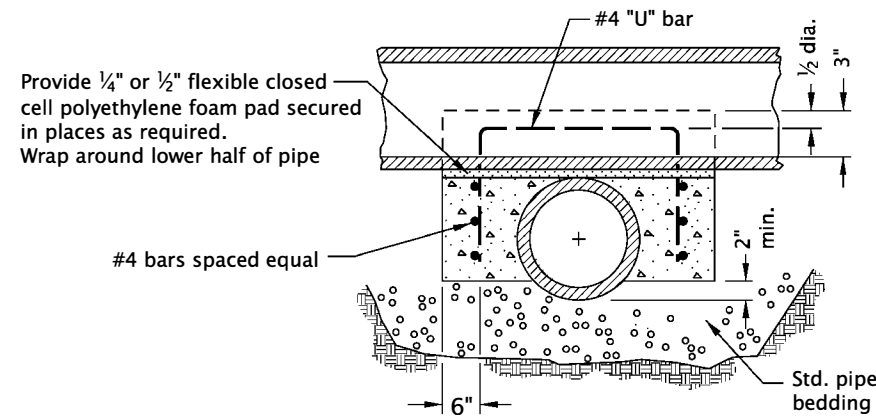


PLAN

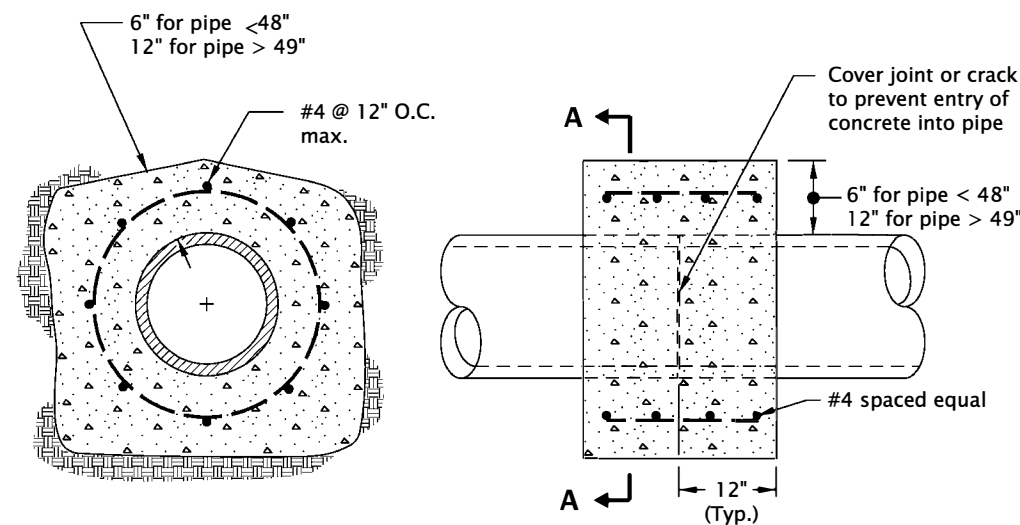
SADDLE



SECTION B-B

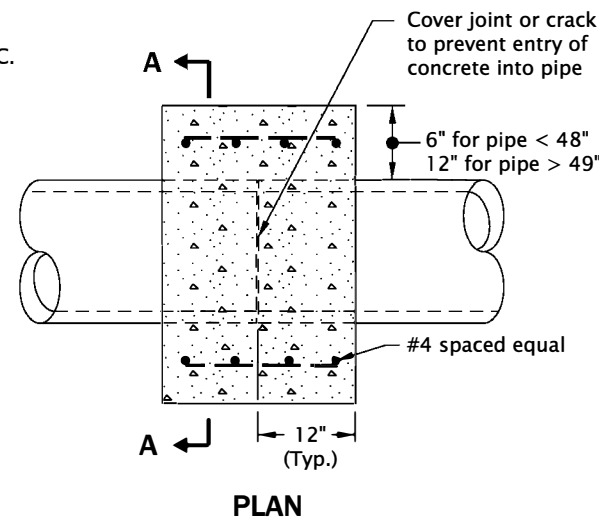


SECTION C-C



SECTION A-A

REINFORCED CONCRETE COLLAR



PLAN

- GENERAL NOTES FOR ALL DETAILS ON THIS SHEET:**
1. All concrete shall be commercial grade concrete.
 2. End all reinforcing 3" clear of ground, forms or top surface, unless otherwise shown.
 3. Trowel finish top surface of saddle, and cradle.
 4. Reinforcement shall be # 4 vertical & horizontal bars as shown.
 5. See Std. Dwg. RD300 for trench backfill, bedding, etc.
 6. See Std. Dwg. RD336 for tracer wire details (When required).
 7. Pipe over 72" diameter are structures, and are not applicable to this drawing.

CALC. BOOK NO. N/A SDR DATE 14-JUL-2014

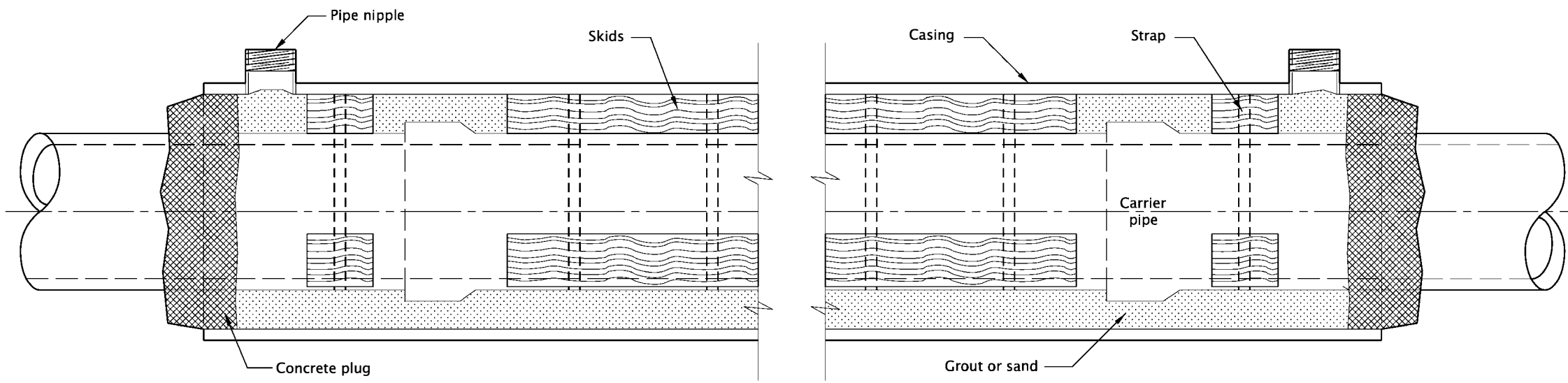
NOTE: All material and workmanship shall be in accordance with the current City of The Dalles Standard Specifications

CITY OF THE DALLES STANDARD DRAWINGS
CONCRETE ENCASEMENT, CRADLE, AND CAP DETAILS
 2025

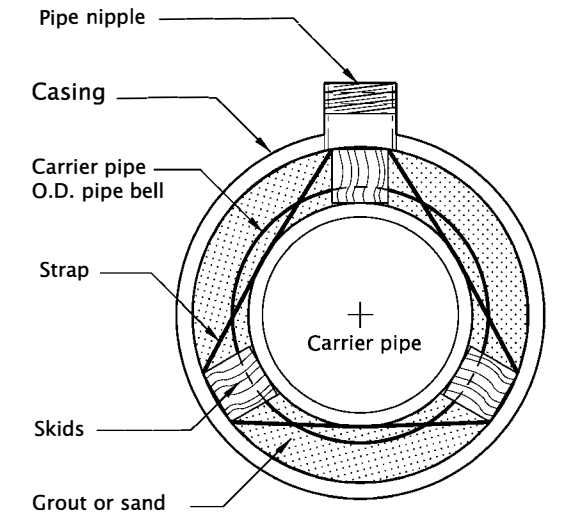
DATE	REVISION DESCRIPTION

The selection and use of this Standard Drawing, while designed in accordance with generally accepted engineering principles and practices, is the sole responsibility of the user and should not be used without consulting a Registered Professional Engineer.

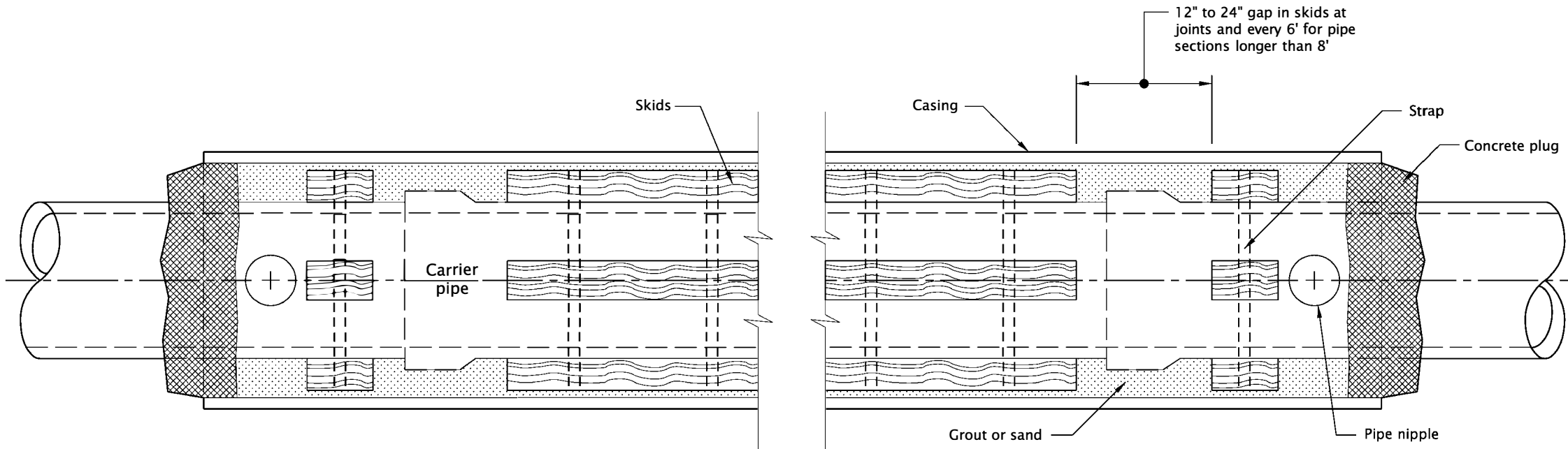
rd308.dgn 20-JUL-2020



ELEVATION



END VIEW



PLAN

GENERAL NOTES FOR ALL DETAILS ON THIS SHEET:

1. Type, size, and location(s) of casing, carrier pipe, skids, straps, pipe nipples, etc., are as required by the Engineer to meet site conditions.
2. Plug ends of casing with commercial grade concrete.
3. Block carrier pipe down or flood to resist flotation when filling annular space.
4. Provide pipe nipple at top of casing at each end of casing, for filling and verifying filling operation. Size to accommodate volume of grout or sand and site conditions (4" diameter minimum).
5. Strap pressure treated wood or manufactured skids to pipe, 3 skids per pipe section. Skids to support full length of pipe except bell.
6. See Std. Dwg. RD336 for tracer wire details (When required).

CALC. BOOK NO. N/A

SDR DATE 07-JAN-2013

NOTE: All material and workmanship shall be in accordance with the current City of The Dalles Standard Specifications

CITY OF THE DALLES STANDARD DRAWINGS

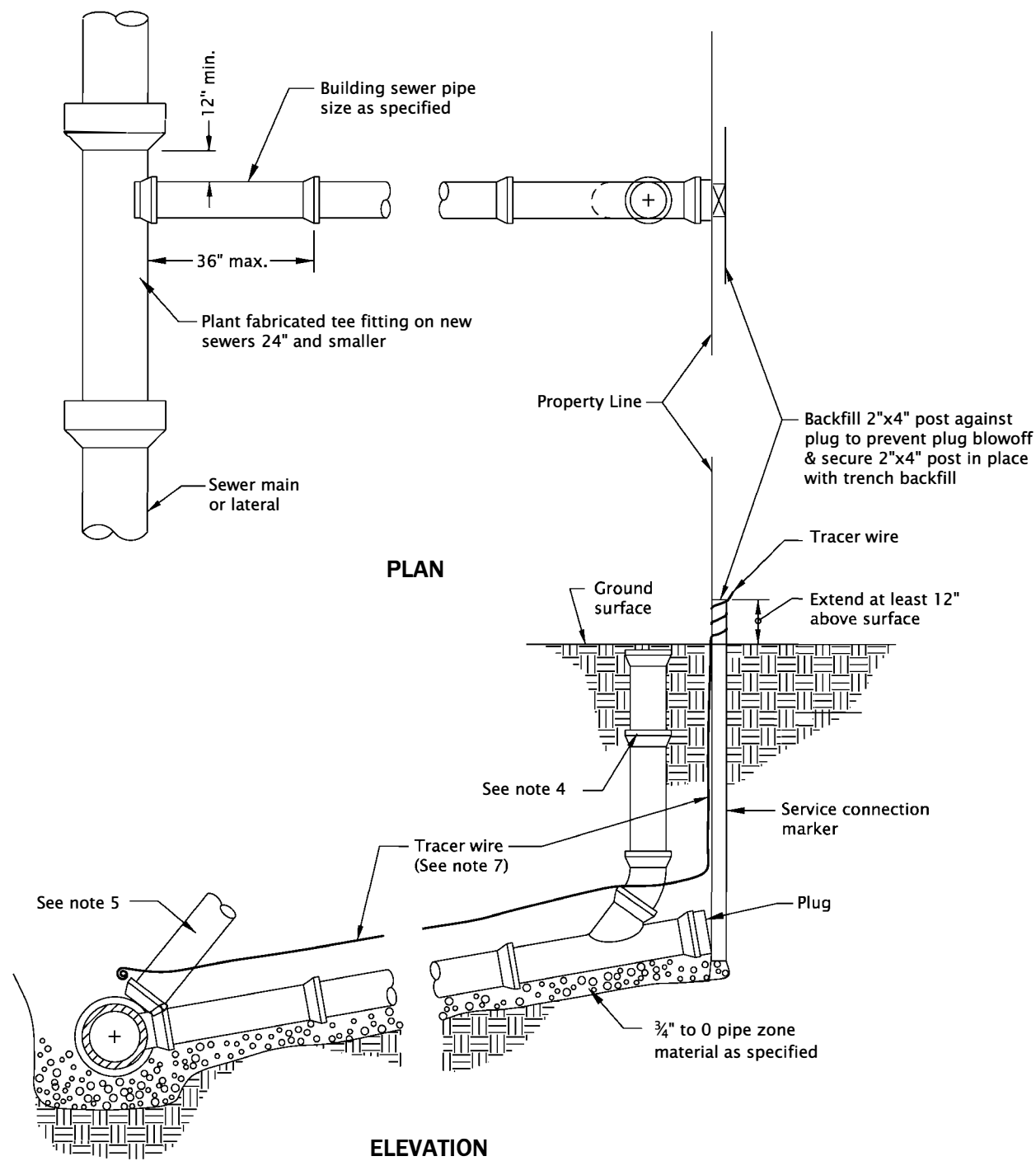
BORE CASING DETAIL

2025

DATE	REVISION	DESCRIPTION

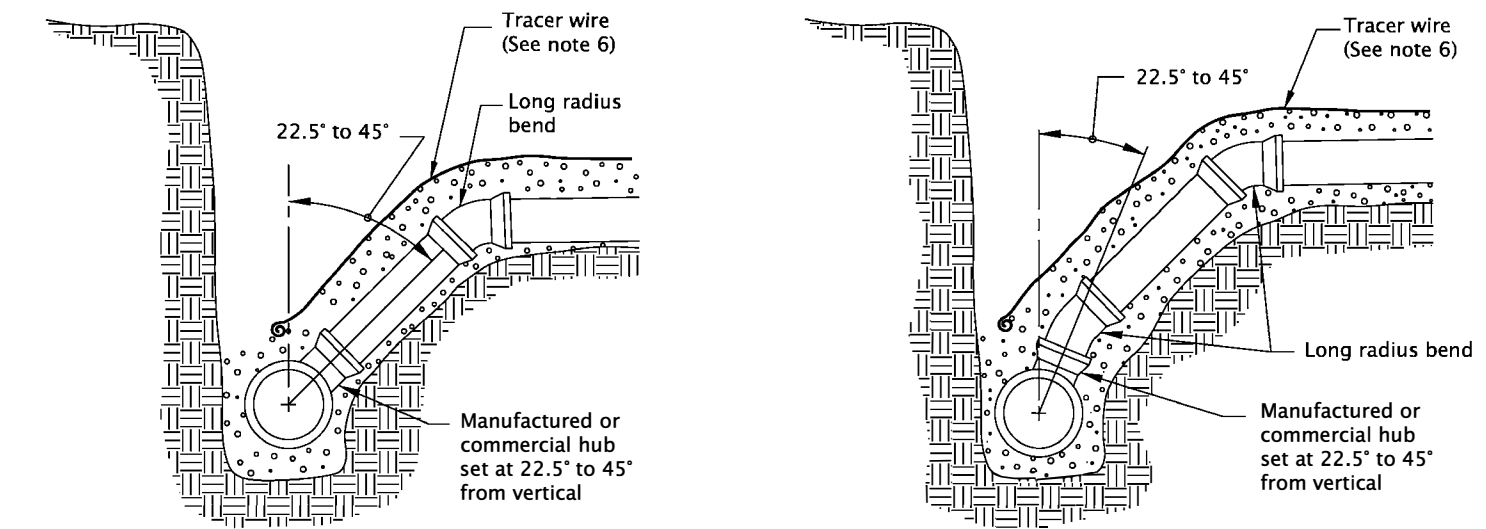
The selection and use of this Standard Drawing, while designed in accordance with generally accepted engineering principles and practices, is the sole responsibility of the user and should not be used without consulting a Registered Professional Engineer.

RD308



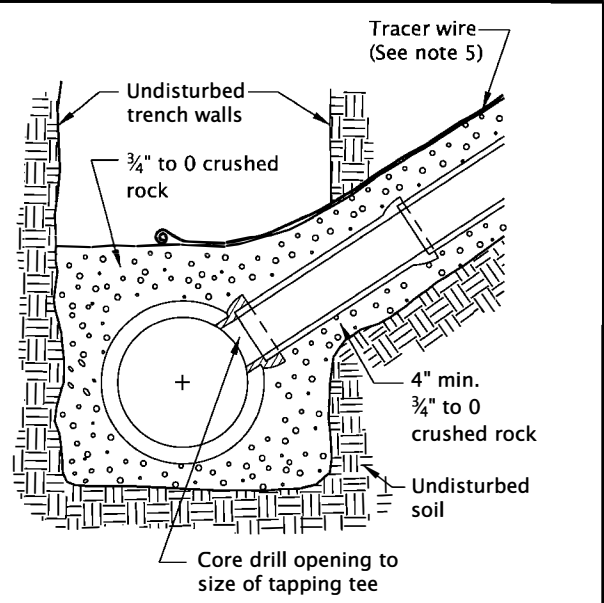
SHALLOW TRENCH SERVICE

- NOTES:
1. Pipe and fittings shall be compatible. Only manufactured fittings shall be used.
 2. Minimum depth at right of way or easement line shall be 4'. Depths less than 2 feet shall have concrete cap per RD306.
 3. Marker posts and blocking shall be treated wood. Post shall be 2"x4" fir. Post to extend 12" minimum above finish grade and exposed area shall be painted green.
 4. A cleanout shall be installed per RD362 at property line or where located by Engineer.
 5. Lay building sewer at max. 45° from horizontal to achieve required depth at property line when minimum slope results in excessive depth.
 6. For bedding and backfill see Std. Dwg. RD300.
 7. See Std. Dwg. RD336 for tracer wire details.



DEEP TRENCH SERVICE

- NOTES:
1. Pipe and fittings shall be compatible. Only manufactured fittings shall be used.
 2. For details not shown see shallow trench service connection drawing.
 3. Vertical trench walls are required. If it is not possible to maintain vertical trench walls, use alternate connection method to maintain 6" maximum distance between riser pipe and trench walls. Replace all excavated or disturbed material with full depth granular backfill compacted to 95% relative density.
 4. Where deep connection is at an angle less than 45° from vertical, ductile iron pipe and fittings should be used.
 5. For bedding and backfill, see Std. Dwg. RD300.
 6. See Std. Dwg. RD336 for tracer wire details.

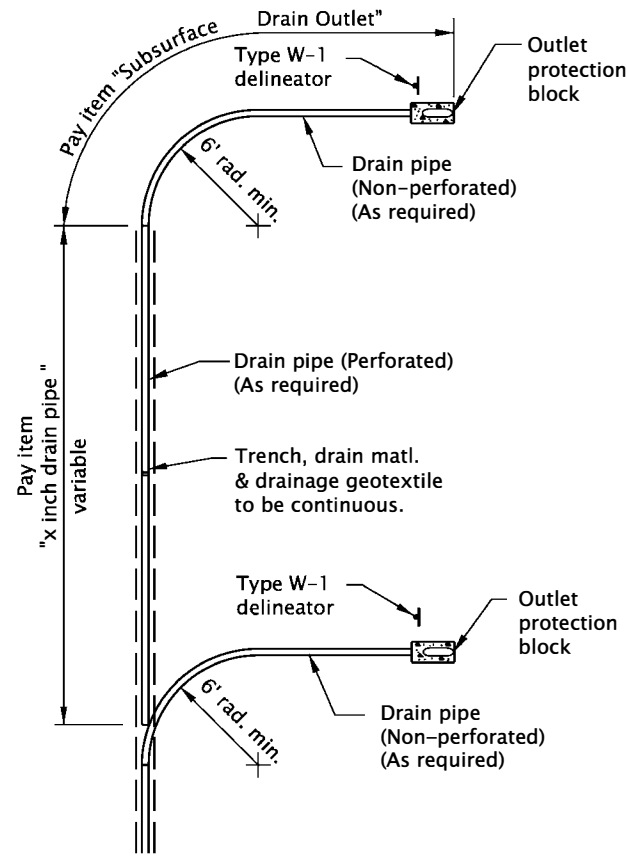


WASTEWATER SERVICE TAP

- NOTES:
1. Seat tee in place to fit outside surface of carrier pipe and to form watertight seal.
 2. Type of tapping tee shall be watertight and conform to standard specification requirements.
 3. Tapping tee shall not protrude into pipe except as approved by the engineer.
 4. For bedding and backfill, see Std. Dwg. RD300.
 5. See Std. Dwg. RD336 for tracer wire details.

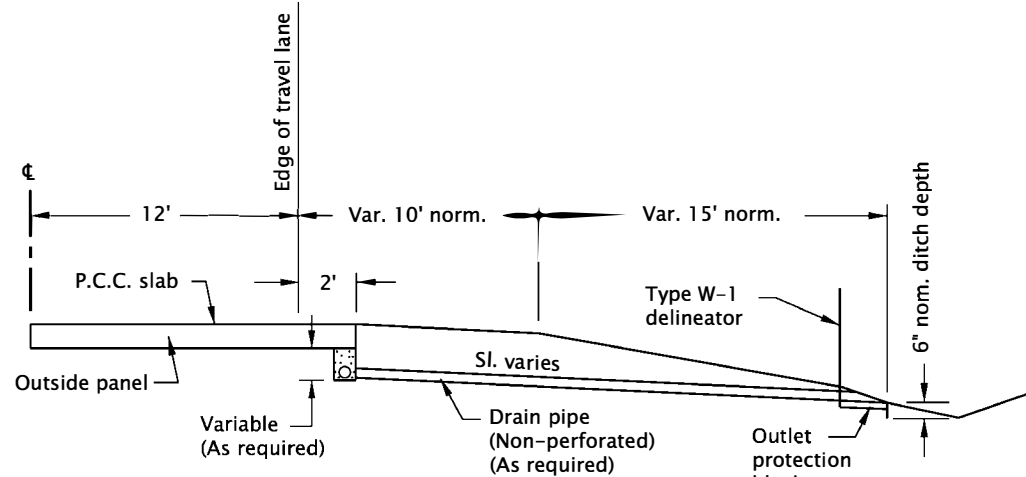
CALC. BOOK NO. <u> N/A </u>	SDR DATE <u> 21-JUL-2015 </u>
NOTE: All material and workmanship shall be in accordance with the current City of The Dalles Standard Specifications	
CITY OF THE DALLES STANDARD DRAWINGS	
SHALLOW/DEEP TRENCH SERVICE CONNECTION, BLOCKING AND MARKERS	
2025	
DATE	REVISION DESCRIPTION

The selection and use of this Standard Drawing, while designed in accordance with generally accepted engineering principles and practices, is the sole responsibility of the user and should not be used without consulting a Registered Professional Engineer.

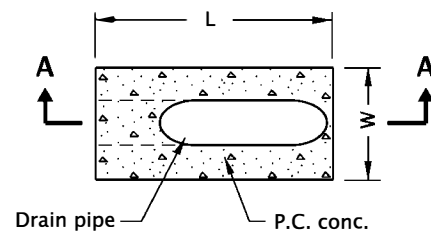
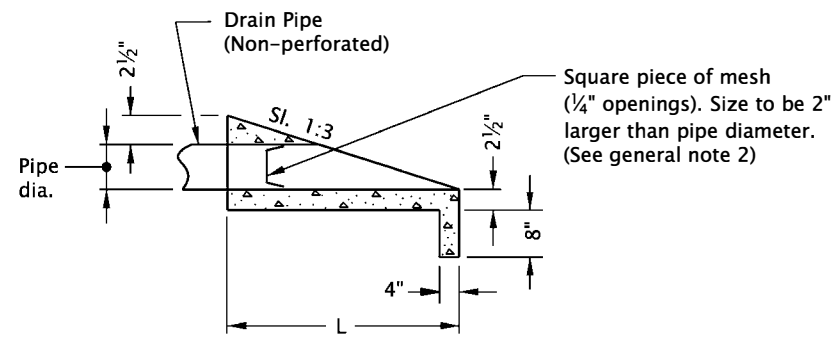


PIPE DIA. (in)	L NOM. (in)	W NOM. (in)
3	24	12
4	24	12
6	33	14
8	42	16

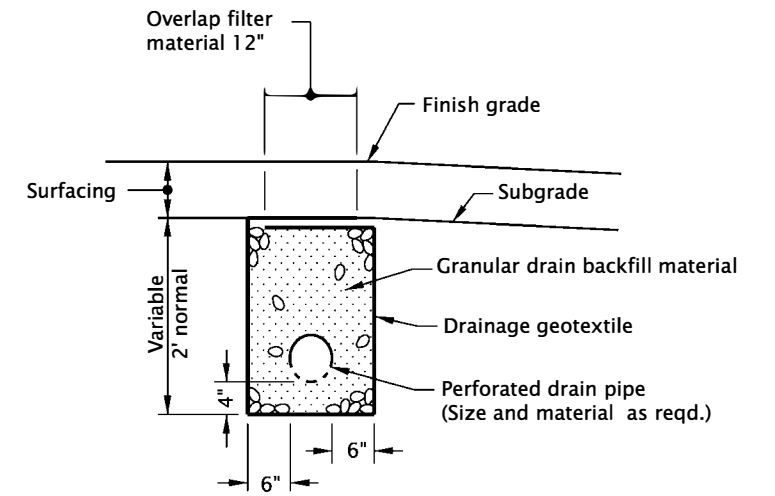
TYPE 1 SUBSURFACE DRAIN INSTALLATION



SUBSURFACE DRAIN OUTLET



OUTLET PROTECTION BLOCK



SUBSURFACE DRAIN DETAIL

GENERAL NOTES FOR ALL DETAILS ON THIS SHEET:

1. In guard rail areas extend outlet protection block to back of guard rail post min.
2. Mesh for rodent control to be galvanized wire or approved equal.

CALC. BOOK NO. N/A

SDR DATE 21-JUL-2015

NOTE: All material and workmanship shall be in accordance with the current City of The Dalles Standard Specifications

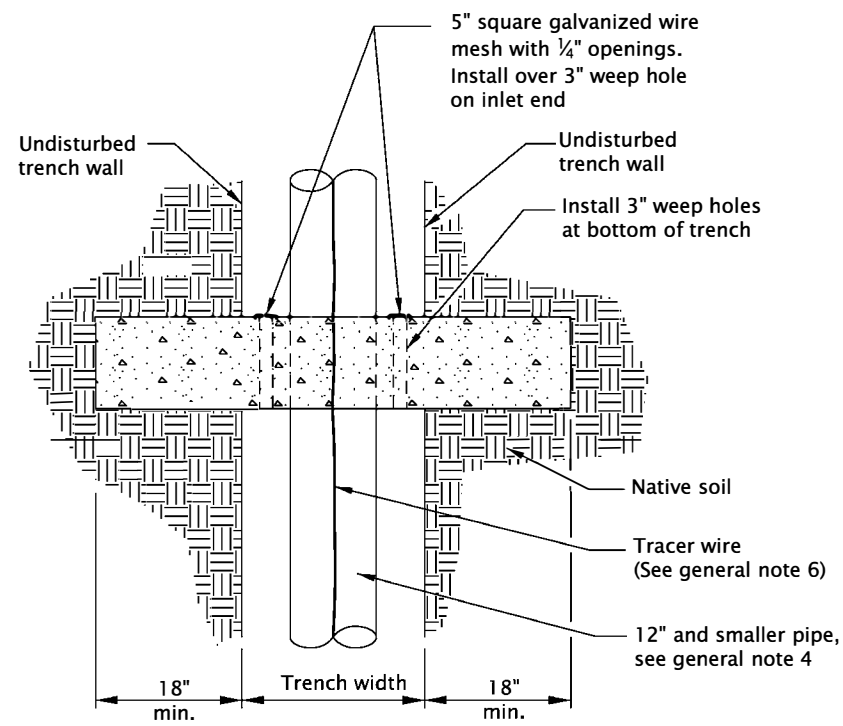
CITY OF THE DALLES STANDARD DRAWINGS

SUBSURFACE DRAIN

2025

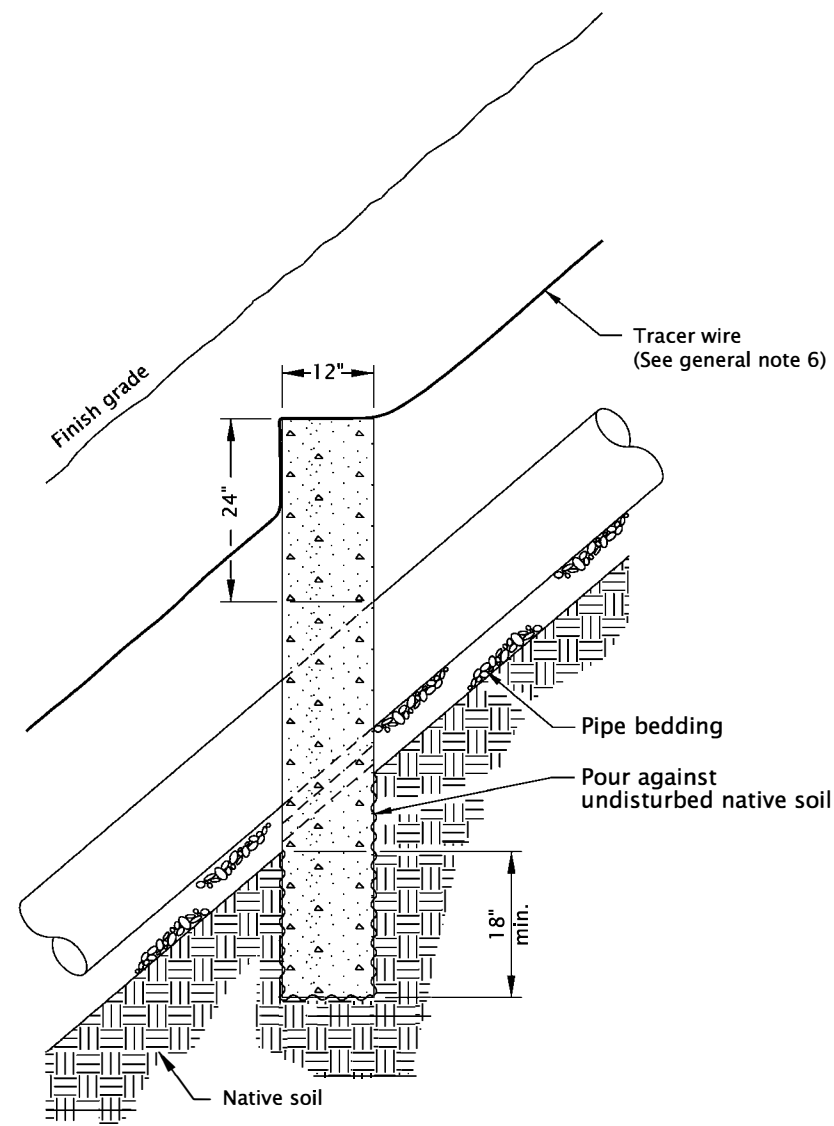
DATE	REVISION	DESCRIPTION

The selection and use of this Standard Drawing, while designed in accordance with generally accepted engineering principles and practices, is the sole responsibility of the user and should not be used without consulting a Registered Professional Engineer.



PLAN

Metal pipe requires polymeric coating when using slope anchors made with concrete.



ELEVATION

GENERAL NOTES FOR ALL DETAILS ON THIS SHEET:

- Concrete pipe anchors shall be constructed using forms when sewers, storm drains and other pipelines are constructed with slopes 20% or greater. Remove forms prior to backfilling trench.
- All concrete shall be commercial grade concrete.
- Center to center max. spacing of concrete pipe anchors shall be:

SLOPE	SPACING (on slope)
20-34%	35'
35-50%	25'
50+ %	15' or concrete encasement
- Dimensions for embedment for pipes larger than 12" shall be approved by the engineer.
- See Std. Dwgs. RD300 & RD304 for pipe installation details.
- See Std. Dwg. RD336 for tracer wire details (When required).

CALC. BOOK NO. N/A

SDR DATE 12-JAN-2015

NOTE: All material and workmanship shall be in accordance with the current City of The Dalles Standard Specifications

CITY OF THE DALLES STANDARD DRAWINGS

PIPE SLOPE ANCHORS - CONCRETE

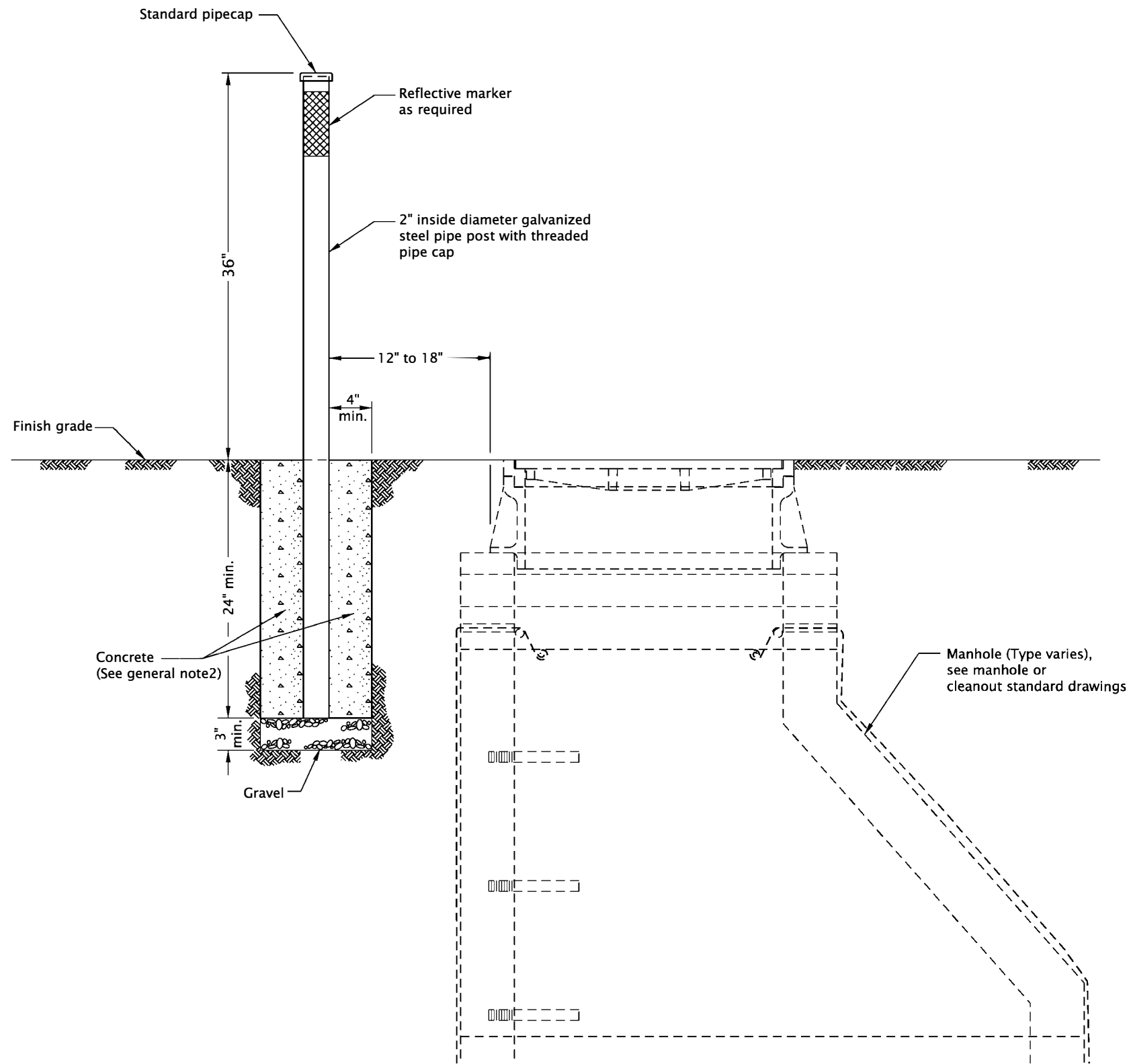
2025

DATE	REVISION	DESCRIPTION

The selection and use of this Standard Drawing, while designed in accordance with generally accepted engineering principles and practices, is the sole responsibility of the user and should not be used without consulting a Registered Professional Engineer.

rd334.dgn 20-JUL-2020

RD334



LOCATOR POST AT MANHOLE OR CLEANOUT

AMERICAN PUBLIC WORKS ASSOCIATION UNIFORM COLOR CODE	
RED	Electric power lines, cables or conduits, and lighting cables.
YELLOW	Gas, oil, steam, petroleum or other hazardous liquid or gaseous materials.
ORANGE	Communications, cable TV, alarm or signal lines, cables, or conduits.
BLUE	Water, irrigation, and slurry lines.
GREEN	Sewers, storm sewer facilities, or other drain lines.
WHITE	Proposed excavation
PINK	Temporary survey markings.
PURPLE	Reclaimed water, irrigation and slurry lines.

GENERAL NOTES FOR ALL DETAILS ON THIS SHEET:

1. As directed the locator post shall be located on the straight side of manhole cone.
2. Steel posts shall be set in commercial grade concrete.
3. Posts located in areas subject to traffic shall be flexible, durable plastic.
4. Flexible, durable plastic marker shall be a PEXCO Flexi Guide FG 542 with a FG 95 Plastic Anchor, or approved equal.
5. Posts shall be painted color as directed.

CALC. BOOK NO. N/A SDR DATE 16-JUL-2018

NOTE: All material and workmanship shall be in accordance with the current City of The Dalles Standard Specifications

The selection and use of this Standard Drawing, while designed in accordance with generally accepted engineering principles and practices, is the sole responsibility of the user and should not be used without consulting a Registered Professional Engineer.

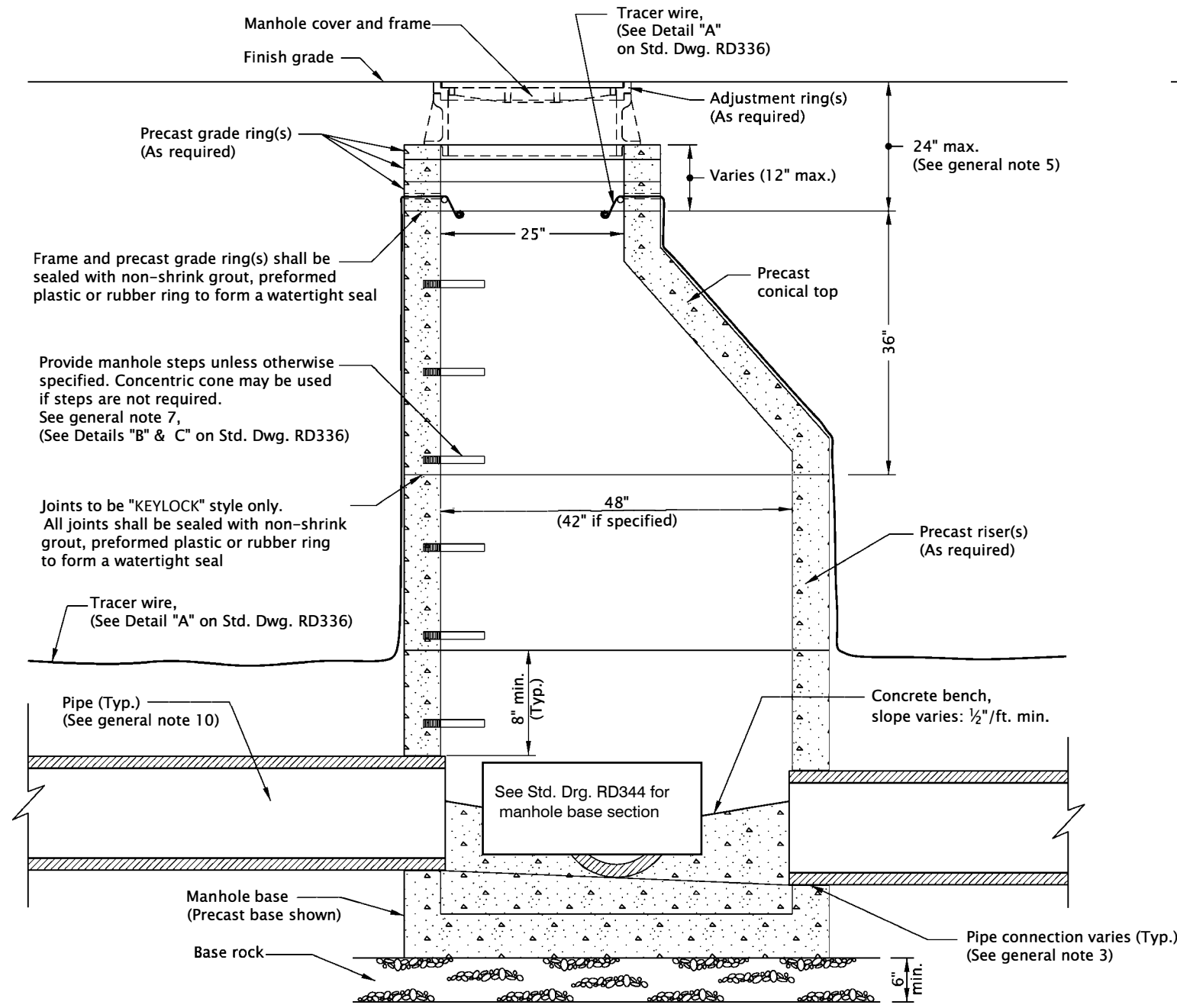
CITY OF THE DALLES STANDARD DRAWINGS

LOCATOR POST

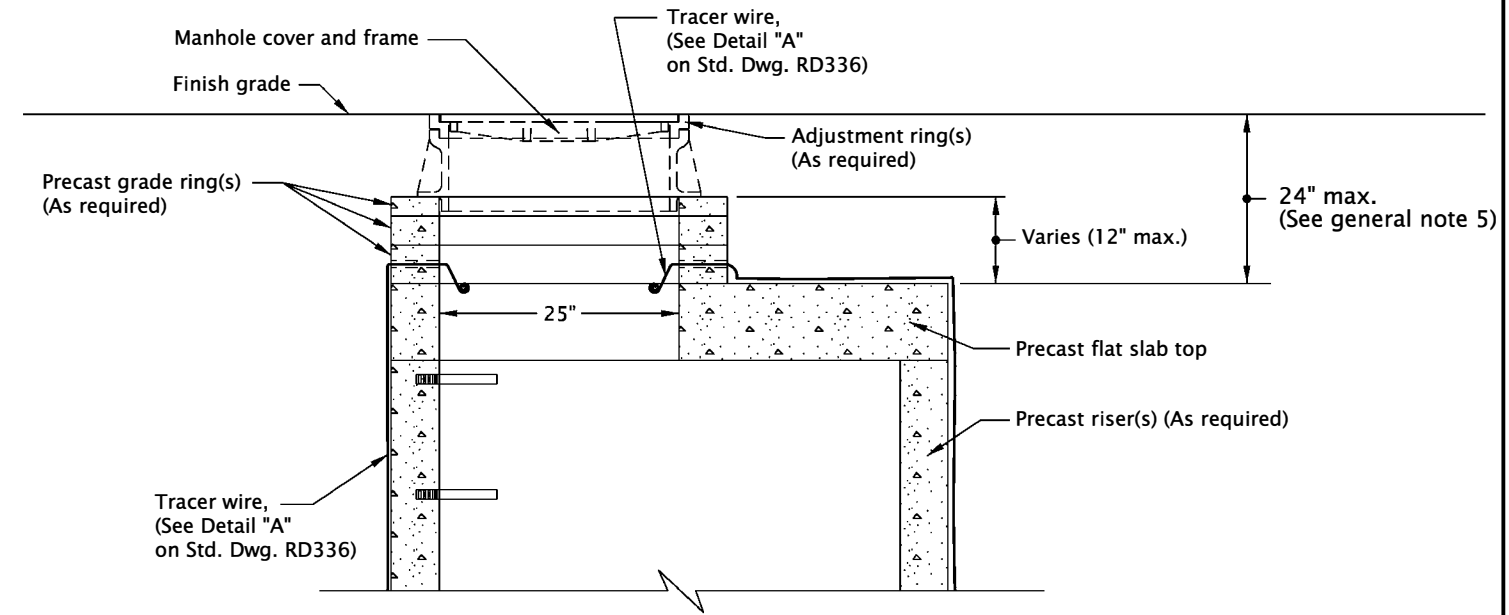
2025

DATE	REVISION	DESCRIPTION

rd335.dgn 20-JUL-2020



MANHOLE WITH PRECAST CONICAL TOP



MANHOLE WITH PRECAST FLAT SLAB TOP

GENERAL NOTES FOR ALL DETAILS ON THIS SHEET:

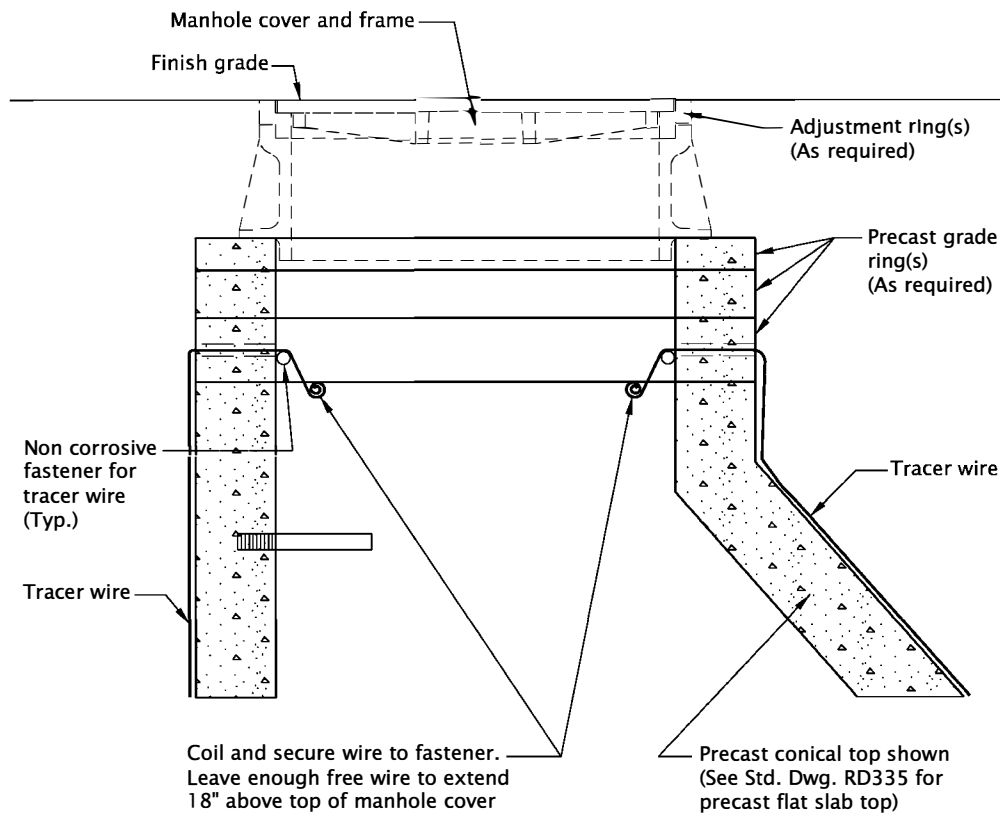
- | | |
|--|--|
| <ol style="list-style-type: none"> 1. All precast products shall conform to requirements of ASTM C478. 2. Standard precast manhole section diameter shall be 48". Use 42" if specified by the Engineer. 3. See Std. Dwg. RD345 for pipe to manhole connections. 4. See Std. Dwg. RD344 for manhole base section. 5. Adjust 24" maximum. 6. All connecting pipes shall have a tracer wire, or approved alternate. | <ol style="list-style-type: none"> 7. See Std. Dwg. RD336 for manhole steps. 8. See Std. Dwg. RD336 for details not shown. 9. See Std. Dwg. RD356 for manhole covers and frames, manhole adjustment rings, etc. 10. Max. pipe diameter varies with pipe material. 11. See Std. Dwg. RD342 for shallow manholes. 12. Location, elevation, diameter, slope, and number of pipe(s) varies, see project plans. |
|--|--|

CALC. BOOK NO. <u>N/A</u>	SDR DATE <u>21-JUN-2019</u>
NOTE: All material and workmanship shall be in accordance with the current City of The Dalles Standard Specifications	
CITY OF THE DALLES STANDARD DRAWINGS	
STANDARD STORM SEWER MANHOLE	
2025	
DATE	REVISION DESCRIPTION

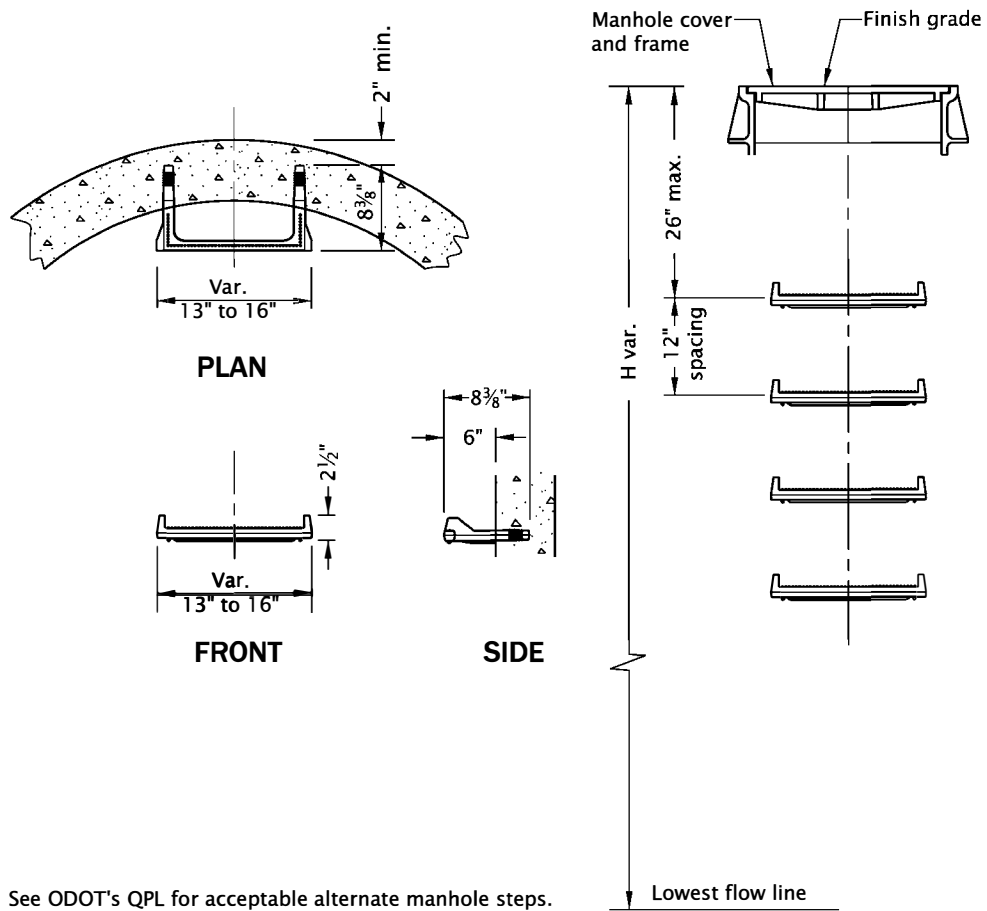
The selection and use of this Standard Drawing, while designed in accordance with generally accepted engineering principles and practices, is the sole responsibility of the user and should not be used without consulting a Registered Professional Engineer.

RD335

rd336.dgn 20-JUL-2020

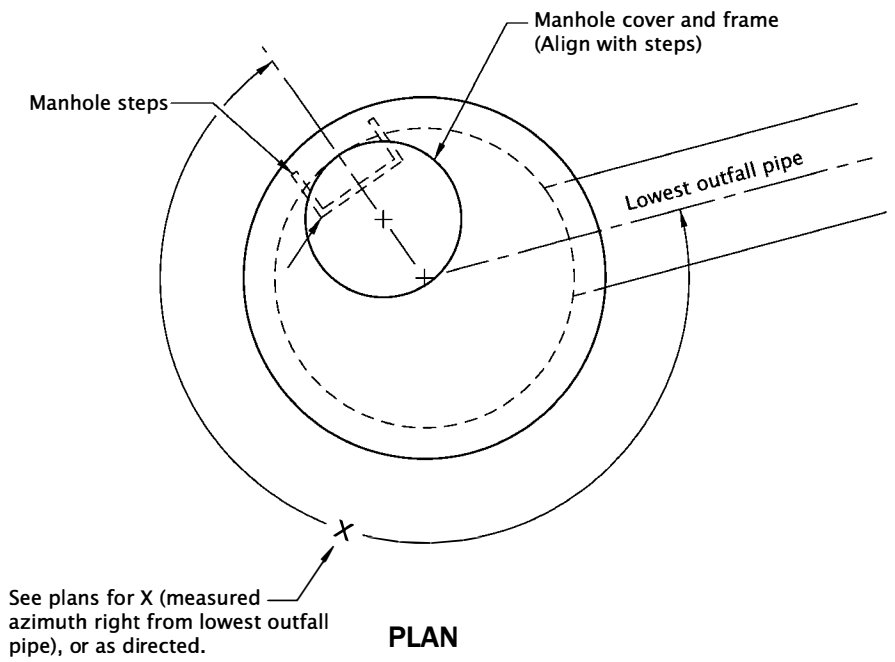


DETAIL "A"
TRACER WIRE
(See general note 6)



See ODOT's QPL for acceptable alternate manhole steps.
NOTE: No conflict with pipe align with available shelf.

DETAIL "B"
MANHOLE STEPS
(See general note 7)



X = 0 degrees, unless specified otherwise on plans

DETAIL "C"
PRECAST CONICAL TOP
OR
PRECAST FLAT SLAB TOP
AND MANHOLE STEPS ORIENTATION
(See general note 7)

GENERAL NOTES FOR ALL DETAILS ON THIS SHEET:

1. All precast products shall conform to requirements of ASTM C478.
2. Standard precast manhole section diameter shall be 48". Use 42" if specified by the Engineer.
3. See Std. Dwg. RD345 for pipe to manhole connections.
4. See Std. Dwg. RD344 for manhole base section.
5. Adjust 24" maximum.
6. All connecting pipes shall have a tracer wire, or approved alternate. Place tracer wire directly over pipe centerline and on top of the pipe zone material.

7. Steps shall conform to requirements of ASTM C478. When H=42" or less omit steps. See Detail "C" for alignment of steps, and manhole cover and frame.
8. See Std. Dwg. RD335 for details not shown.
9. See Std. Dwg. RD356 for manhole covers and frames, manhole adjustment rings, etc.
10. Max. pipe diameter varies with pipe material.
11. See Std. Dwg. RD342 for shallow manholes.
12. See project plans for details not shown.

CALC. BOOK NO. N/A SDR DATE 16-JAN-2019

The selection and use of this Standard Drawing, while designed in accordance with generally accepted engineering principles and practices, is the sole responsibility of the user and should not be used without consulting a Registered Professional Engineer.

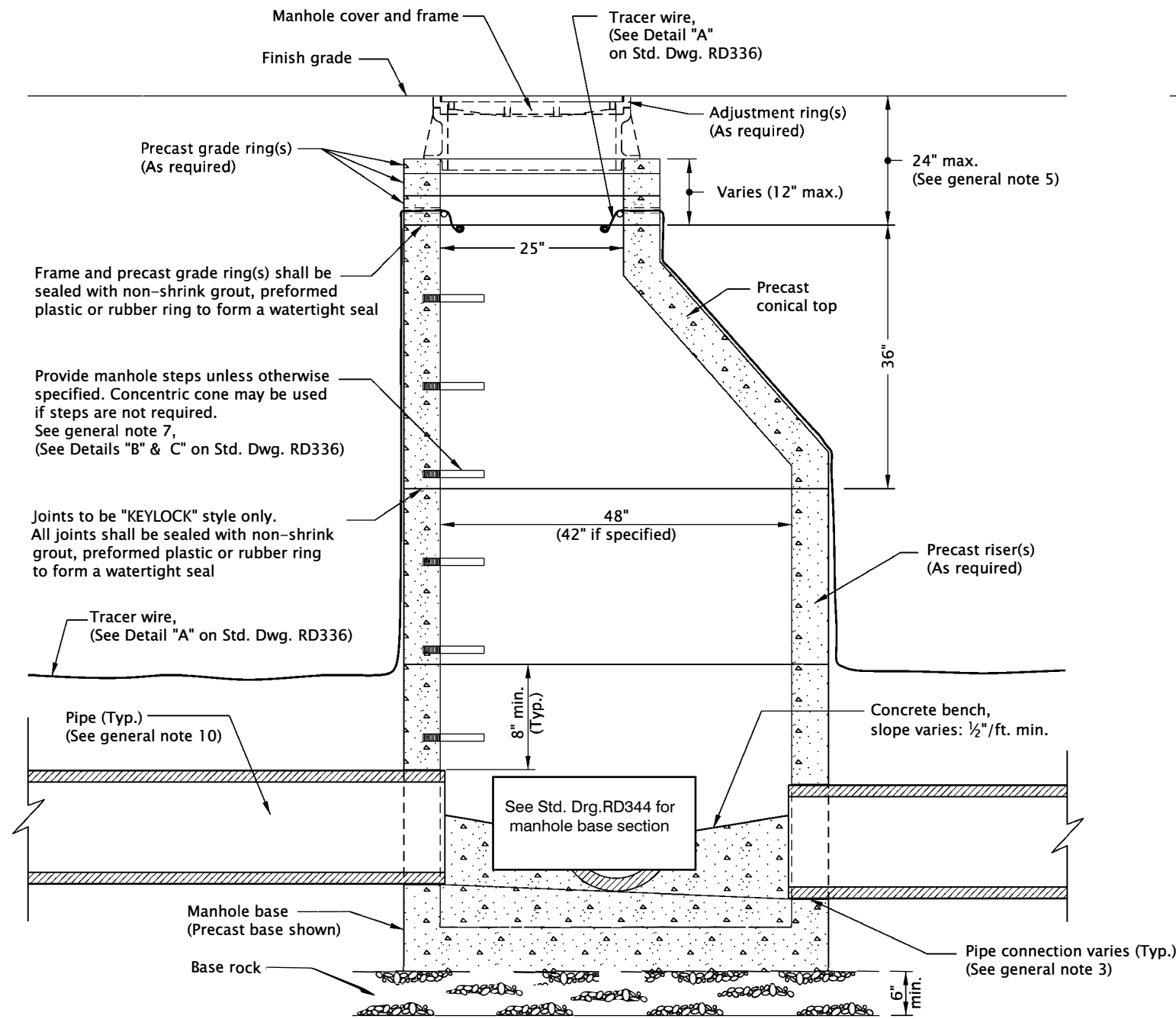
NOTE: All material and workmanship shall be in accordance with the current City of The Dalles Standard Specifications

CITY OF THE DALLES STANDARD DRAWINGS
STANDARD MANHOLE DETAILS

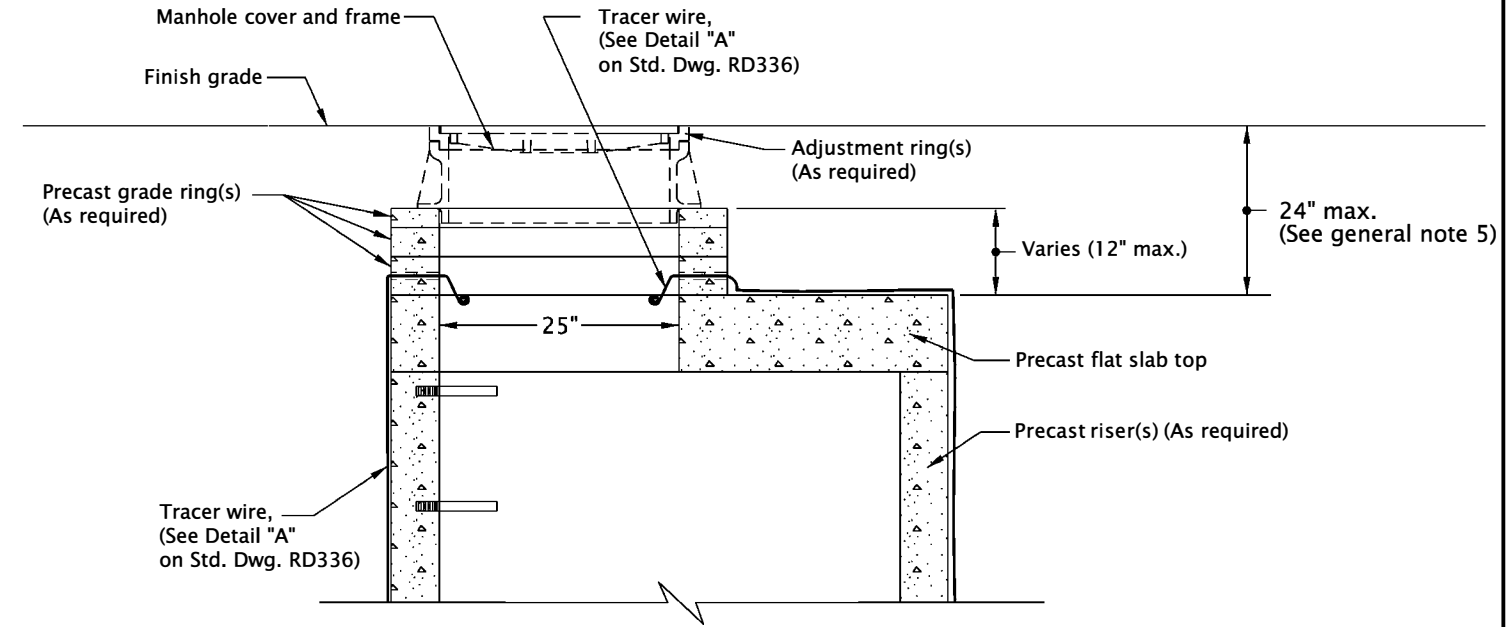
DATE	REVISION	DESCRIPTION
	2025	

RD336

rd338.dgn 20-JUL-2020



MANHOLE WITH PRECAST CONICAL TOP



MANHOLE WITH PRECAST FLAT SLAB TOP

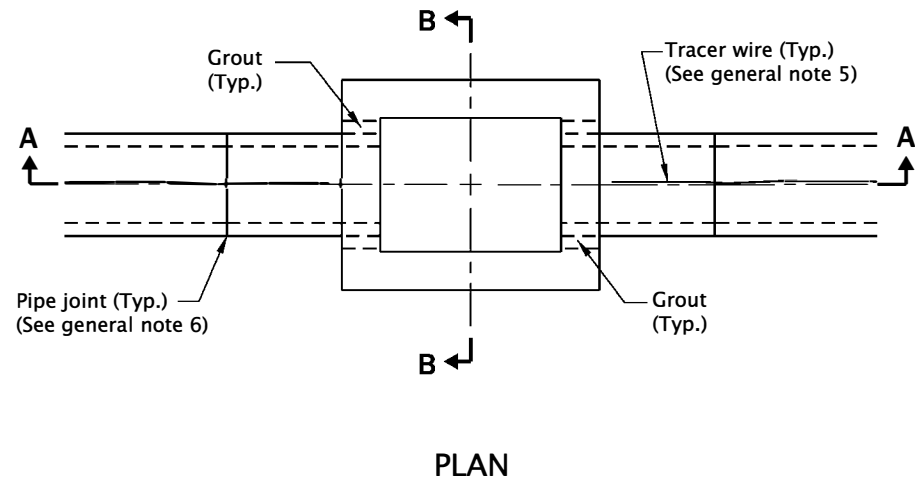
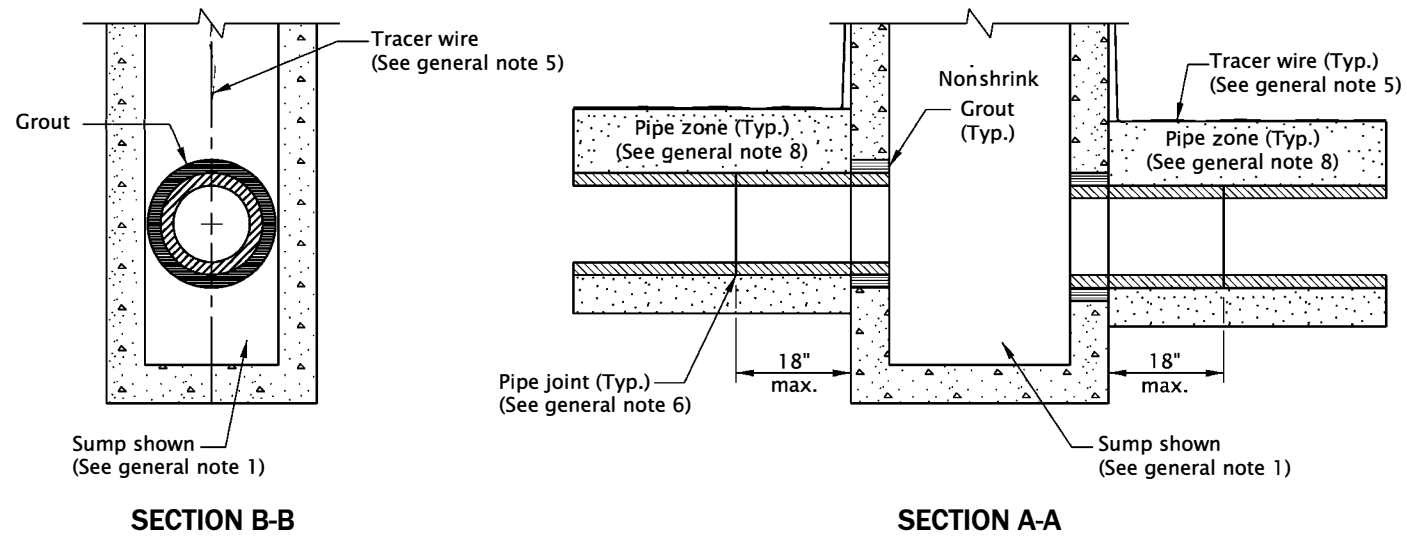
GENERAL NOTES FOR ALL DETAILS ON THIS SHEET:

- | | |
|--|---|
| <p>1. All precast products shall conform to requirements of ASTM C478.</p> <p>2. Standard precast manhole section diameter shall be 48". Use 42" if specified by the Engineer.</p> <p>3. See Std. Dwg. RD345 for pipe to manhole connections.</p> <p>4. See Std. Dwg. RD344 for manhole base section.</p> <p>5. Adjust 24" maximum.</p> <p>6. All connecting pipes shall have a tracer wire, or approved alternate.</p> <p>7. See Std. Dwg. RD336 for manhole steps.</p> | <p>8. See Std. Dwg. RD336 for details not shown.</p> <p>9. See Std. Dwg. RD356 for manhole covers and frames, manhole adjustment rings, etc.</p> <p>10. Max. pipe diameter varies with pipe material.</p> <p>11. See Std. Dwg. RD342 for shallow manholes.</p> <p>12. Location, elevation, diameter, slope, and number of pipe(s) varies, see project plans.</p> <p>13. This detail limited to interior drop of 24". See Std. Dwgs. RD350 or RD352 for drop manhole details for drops in excess of 24".</p> |
|--|---|

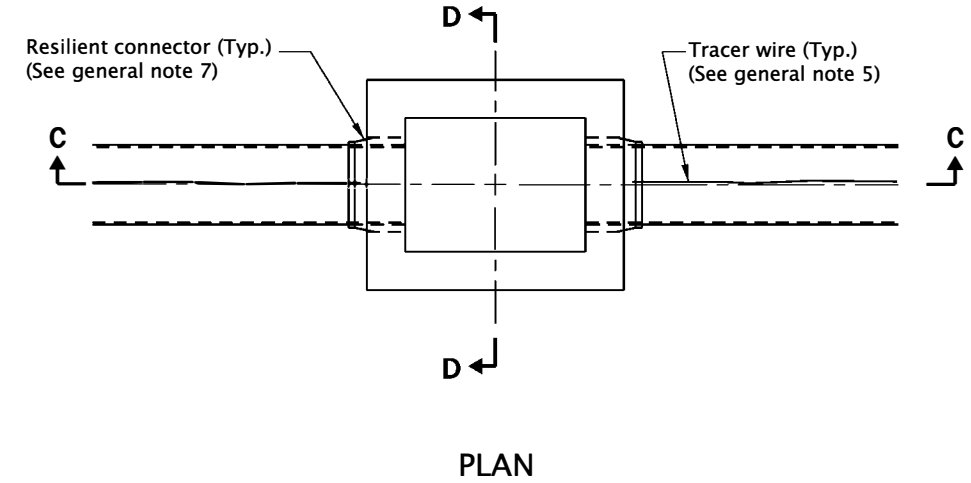
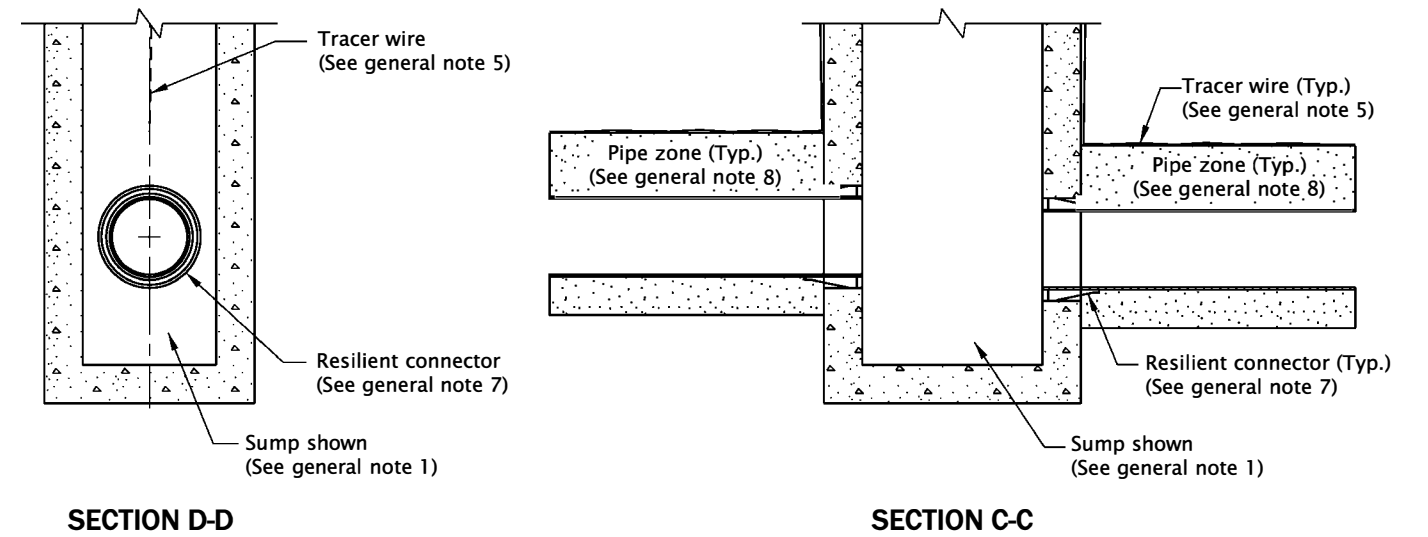
CALC. BOOK NO. <u>N/A</u>	SDR DATE <u>21-JUN-2019</u>
NOTE: All material and workmanship shall be in accordance with the current City of The Dalles Standard Specifications	
CITY OF THE DALLES STANDARD DRAWINGS	
STANDARD SANITARY SEWER MANHOLE	
2025	
DATE	REVISION DESCRIPTION

The selection and use of this Standard Drawing, while designed in accordance with generally accepted engineering principles and practices, is the sole responsibility of the user and should not be used without consulting a Registered Professional Engineer.

RD338



CONNECTION OF RIGID PIPE TO STRUCTURE



CONNECTION OF FLEXIBLE PIPE TO STRUCTURE

GENERAL NOTES FOR ALL DETAILS ON THIS SHEET:

1. See Std. Dwg. RD364, RD365, and RD366 for inlet details not shown.
2. See appropriate standard drawings or special project details for other similar structures.
3. Location, elevation, diameter, slope, and number of pipe(s) varies, see project plans.
4. Maximum pipe diameter varies with pipe material.
5. All connecting pipes shall have a tracer wire, or approved alternate. See Std. Dwg. RD336 for tracer wire details.
6. When flexible pipe is used, install resilient connectors conforming to requirements of ASTM C923.
7. Pipe zone varies, see Std. Dwg. RD300.

CALC. BOOK NO. N/A

SDR DATE 19-JUL-2021

The selection and use of this Standard Drawing, while designed in accordance with generally accepted engineering principles and practices, is the sole responsibility of the user and should not be used without consulting a Registered Professional Engineer.

NOTE: All material and workmanship shall be in accordance with the current City of The Dalles Standard Specifications

CITY OF THE DALLES STANDARD DRAWINGS

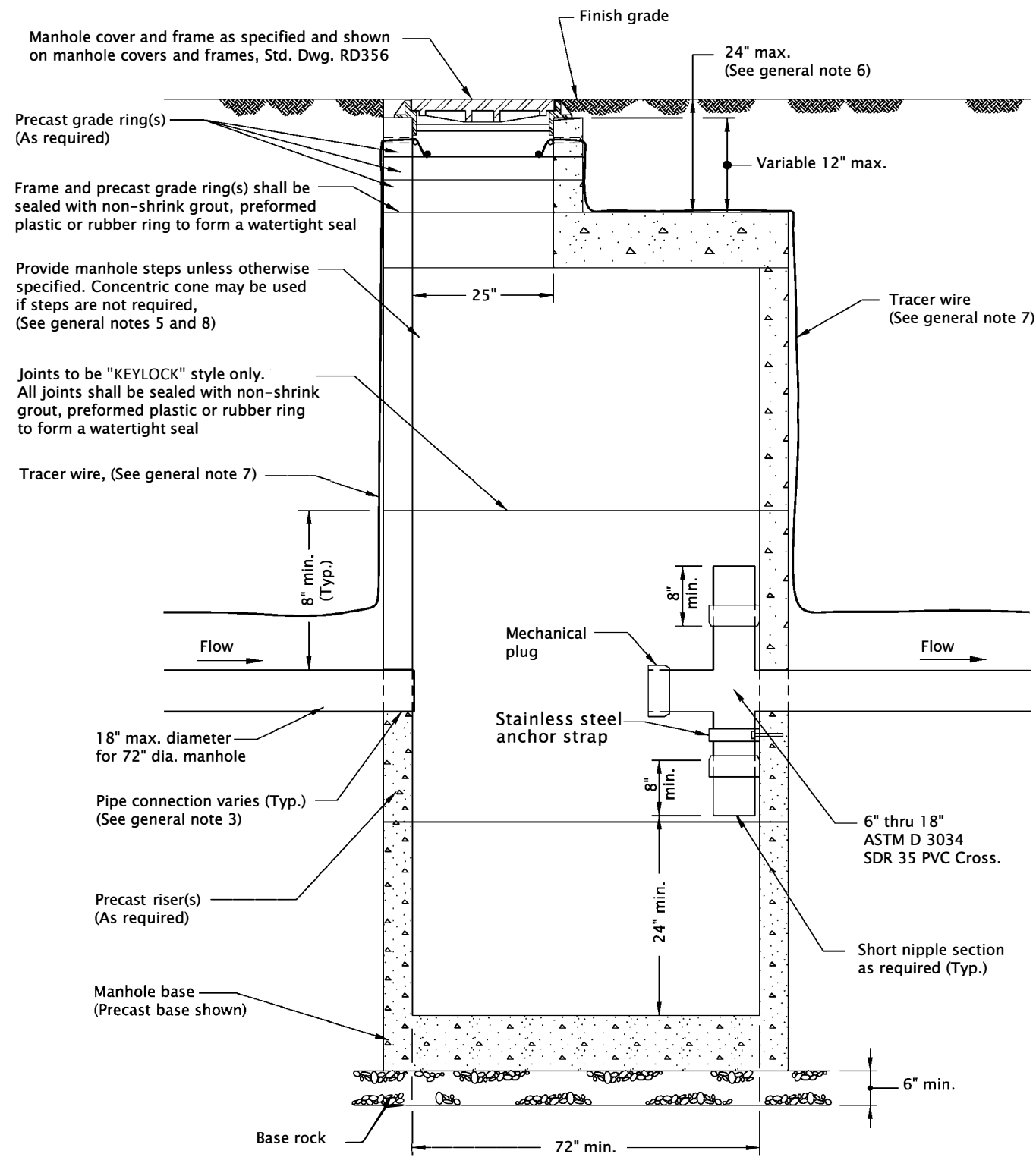
PIPE TO STRUCTURE CONNECTIONS

2025

DATE	REVISION	DESCRIPTION
07-2021	REVISED NOTES	

rd340.dgn 20-JUL-2020

RD340



GENERAL NOTES FOR ALL DETAILS ON THIS SHEET:

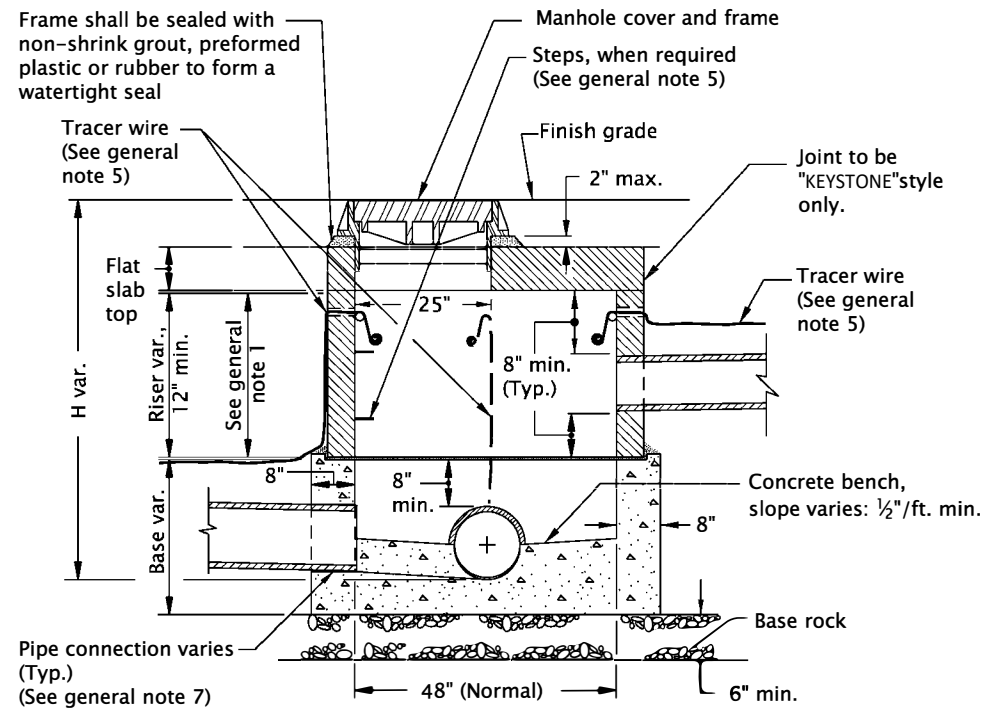
1. All precast products shall conform to requirements of ASTM C478.
2. Standard precast manhole section diameter shall be 72".
3. See Std. Dwg. RD345 for pipe to manhole connections.
4. See Std. Dwg. RD344 for manhole base section, for details not shown.
5. See Std. Dwg. RD336 for manhole steps details, and flat slab top orientation.
6. Adjust 24" max.
7. See Std. Dwg. RD336 for tracer wire details.
8. See Std. Dwg. RD336 for manhole steps.
9. Max. pipe diameter varies with pipe material.
10. Location, elevation, diameter, slope, and number of pipe(s) varies, see project plans.

CALC. BOOK NO. <u>N/A</u>	SDR DATE <u>16-JAN-2019</u>
---------------------------	-----------------------------

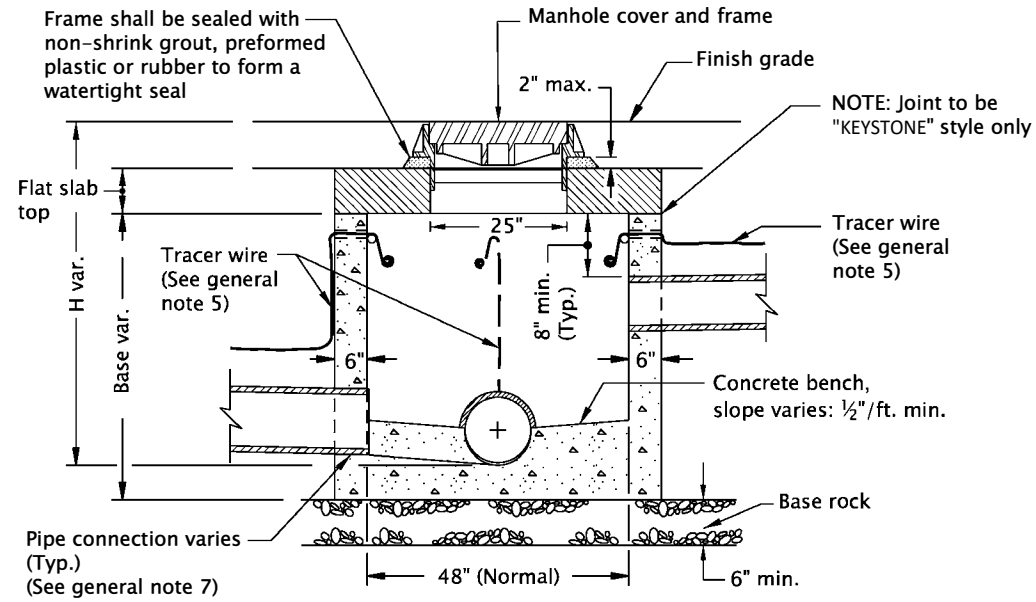
NOTE: All material and workmanship shall be in accordance with the current City of The Dalles Standard Specifications

The selection and use of this Standard Drawing, while designed in accordance with generally accepted engineering principles and practices, is the sole responsibility of the user and should not be used without consulting a Registered Professional Engineer.

CITY OF THE DALLES STANDARD DRAWINGS	
STORM SEWER POLLUTION CONTROL MANHOLE	
2025	
DATE	REVISION DESCRIPTION



SECTION A-A
(Base, Riser & Flat Slab Top)



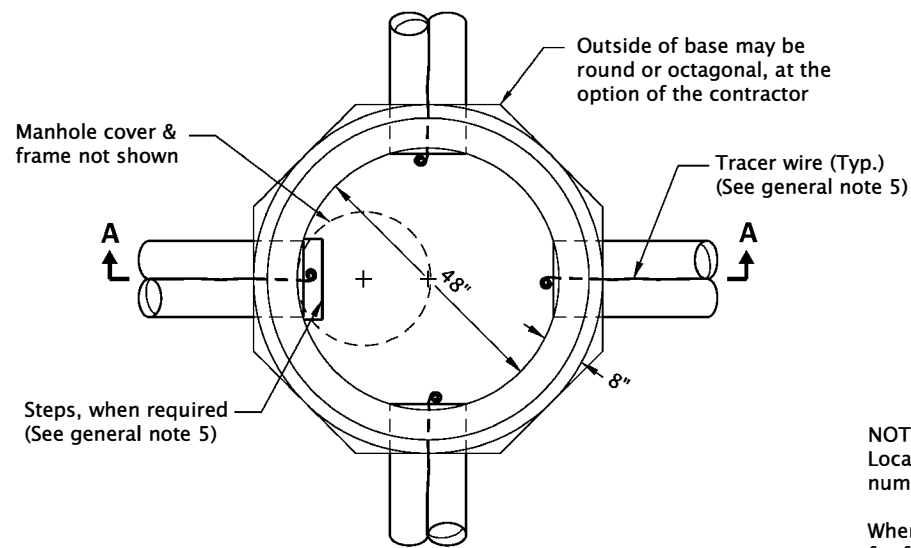
SECTION B-B
(Base, Riser & Flat Slab Top)

LEGEND
(See general note 3)

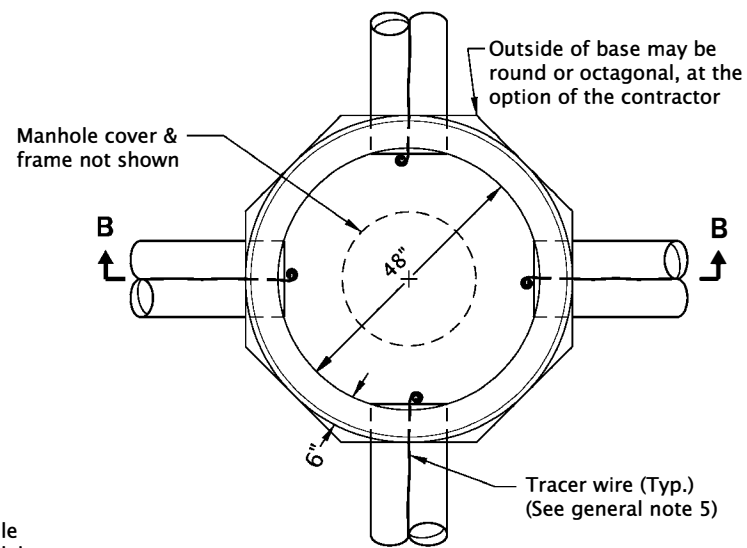
- Cast-in-Place concrete
- Precast concrete
- 1: 2 cement mortar
- Sewer pipe

GENERAL NOTES FOR ALL DETAILS ON THIS SHEET:

1. Minimum length if laterals or connections are inserted: outside diameter of pipe + 17".
2. Use Section B-B when length of riser becomes less than minimum shown.
3. Base may be precast or cast-in-place.
4. All precast products shall conform to the requirements of ASTM C478.
5. See Std. Dwg. RD336 for details not shown.
6. See Std. Dwg. RD344 for manhole base section.
7. See Std. Dwg. RD345 for pipe to manhole connections.
8. See Std. Dwg. RD356 for manhole covers and frames.
9. All concrete shall be commercial grade concrete.
10. Max. pipe diameter varies with pipe material.
11. Location, elevation, diameter, slope, and number of pipe(s) varies, see project plans.



TOP VIEW
(Base, Riser & Flat Slab Top)



TOP VIEW
(Base & Flat Slab Top)

NOTES:
Location, elevation, and number of pipe(s) varies.

When H=42" or less make hole for frame in center of cover slab.

When H=42" or less omit steps.

CALC. BOOK NO. N/A

SDR DATE 21-JUL-2015

NOTE: All material and workmanship shall be in accordance with the current City of The Dalles Standard Specifications

CITY OF THE DALLES STANDARD DRAWINGS

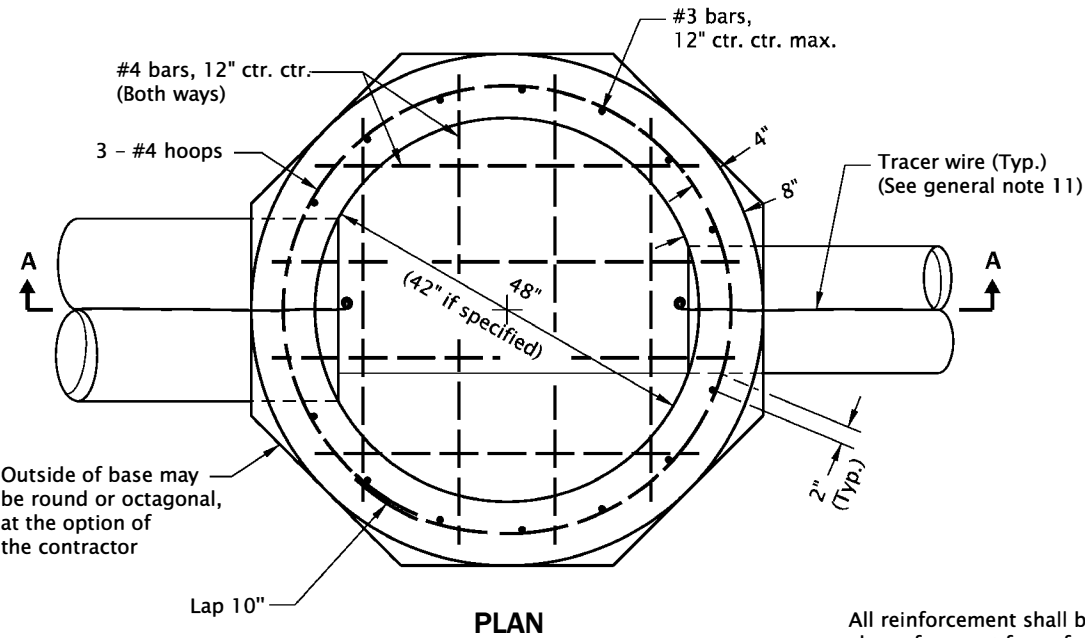
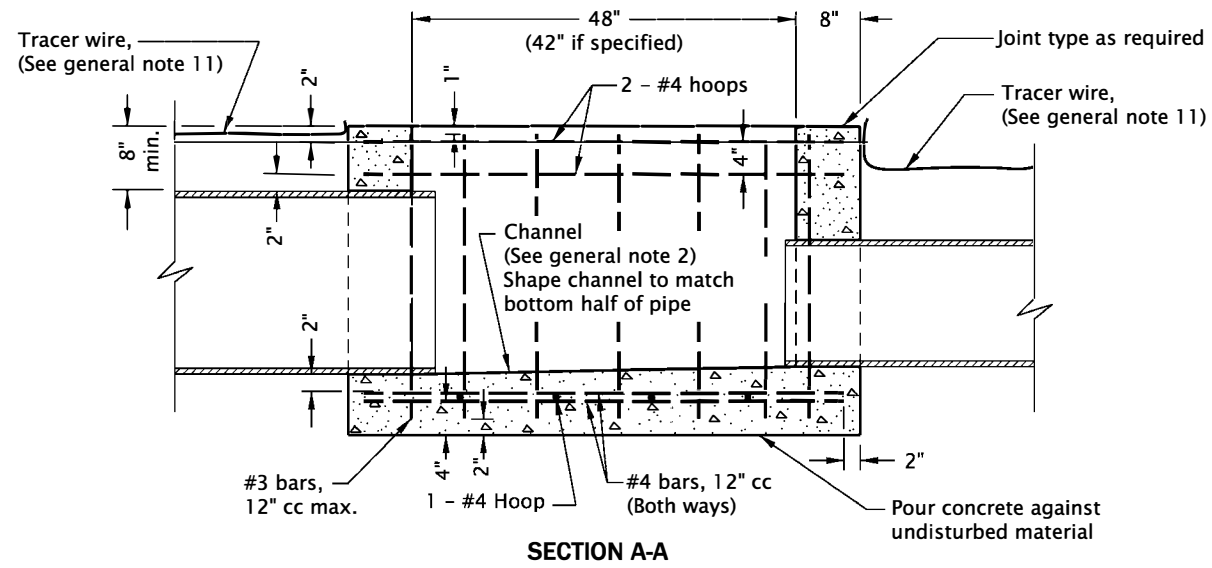
SHALLOW MANHOLES

2025

DATE	REVISION	DESCRIPTION

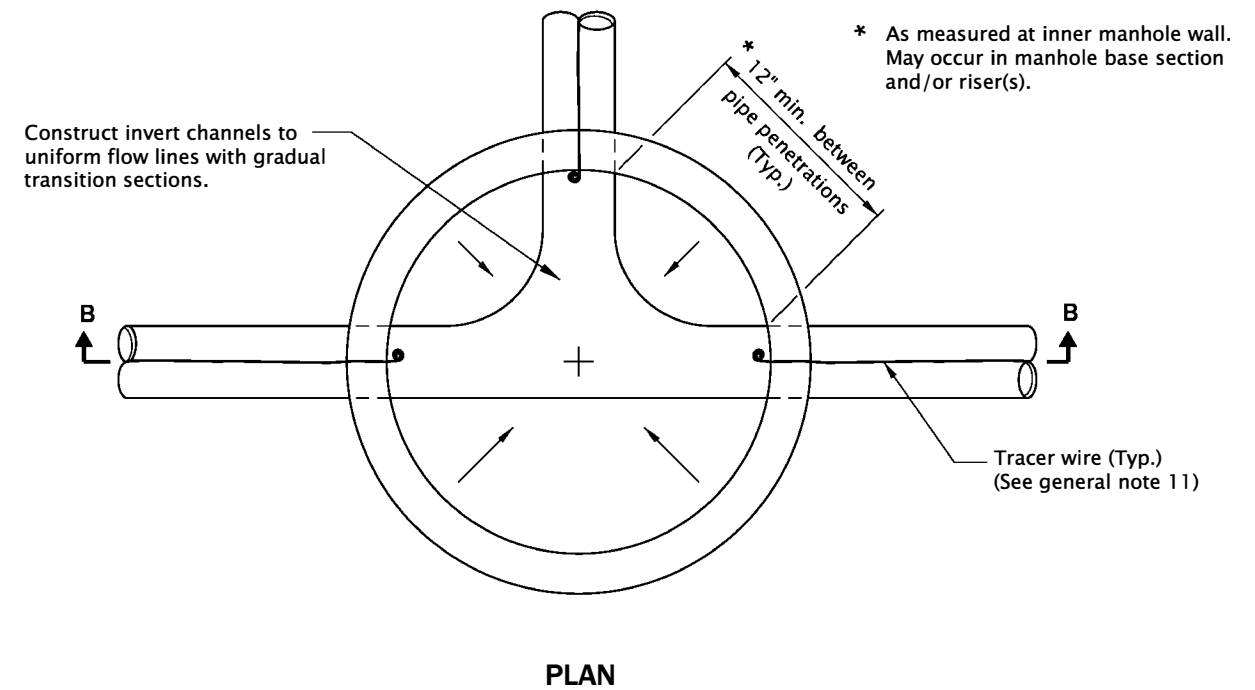
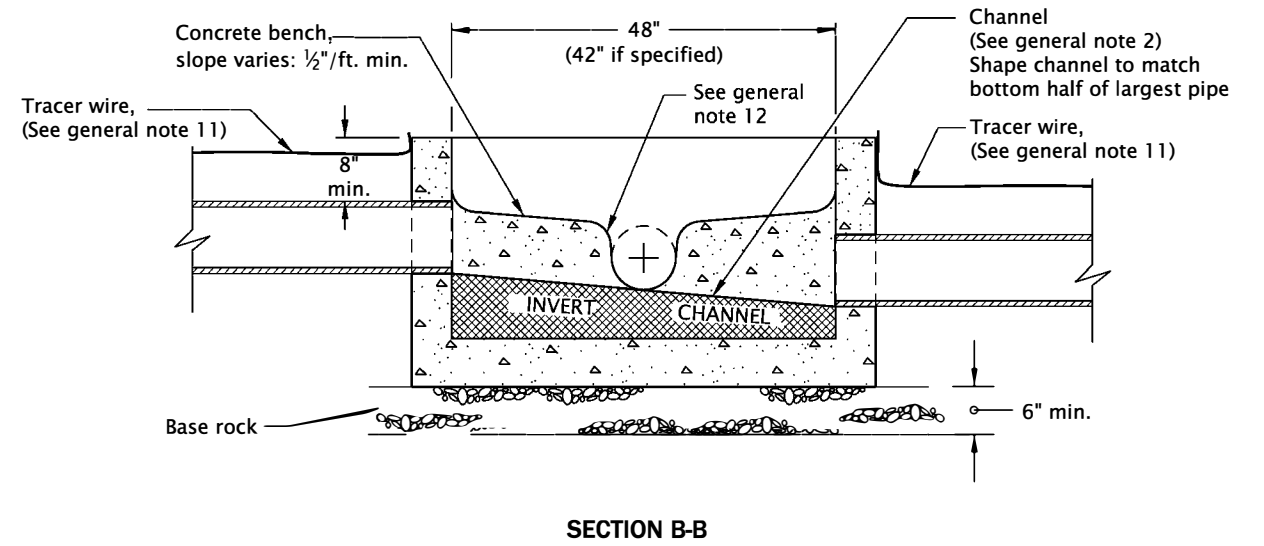
The selection and use of this Standard Drawing, while designed in accordance with generally accepted engineering principles and practices, is the sole responsibility of the user and should not be used without consulting a Registered Professional Engineer.

rd344.dgn 20-JUL-2020



CAST IN PLACE MANHOLE BASE
(For invert channel details, see precast option at right)

All reinforcement shall be 2" clear of nearest face of conc., unless otherwise shown.



PRECAST MANHOLE BASE

* As measured at inner manhole wall. May occur in manhole base section and/or riser(s).

GENERAL NOTES FOR ALL DETAILS ON THIS SHEET:

1. All concrete shall be commercial grade concrete.
2. Channels shall be constructed to provide smooth slopes and radii to outlet pipe.
3. Bases may be precast or cast in place.
4. Max. pipe diameter varies with pipe material.
5. Use on 42" and 48" diameter manhole.
6. Extend pipe into manhole and grout smooth. Pipe(s) may extend 2" max. beyond the interior manhole wall.
7. Location, elevation, diameter, slope, and number of pipe(s) varies, see project plans.
8. All precast products shall conform to the requirements of ASTM C478.
9. See Std. Dwg. RD345 for pipe to manhole connections.
10. See Std. Dwg. RD336 for manhole steps details.
11. See Std. Dwg. RD336 for tracer wire details.
12. At spring line of pipe, extend channel up to crown line on 12:1 batter.

CALC. BOOK NO. N/A

SDR DATE 14-JUL-2014

NOTE: All material and workmanship shall be in accordance with the current City of The Dalles Standard Specifications

CITY OF THE DALLES STANDARD DRAWINGS
STANDARD MANHOLE BASE SECTION

2025

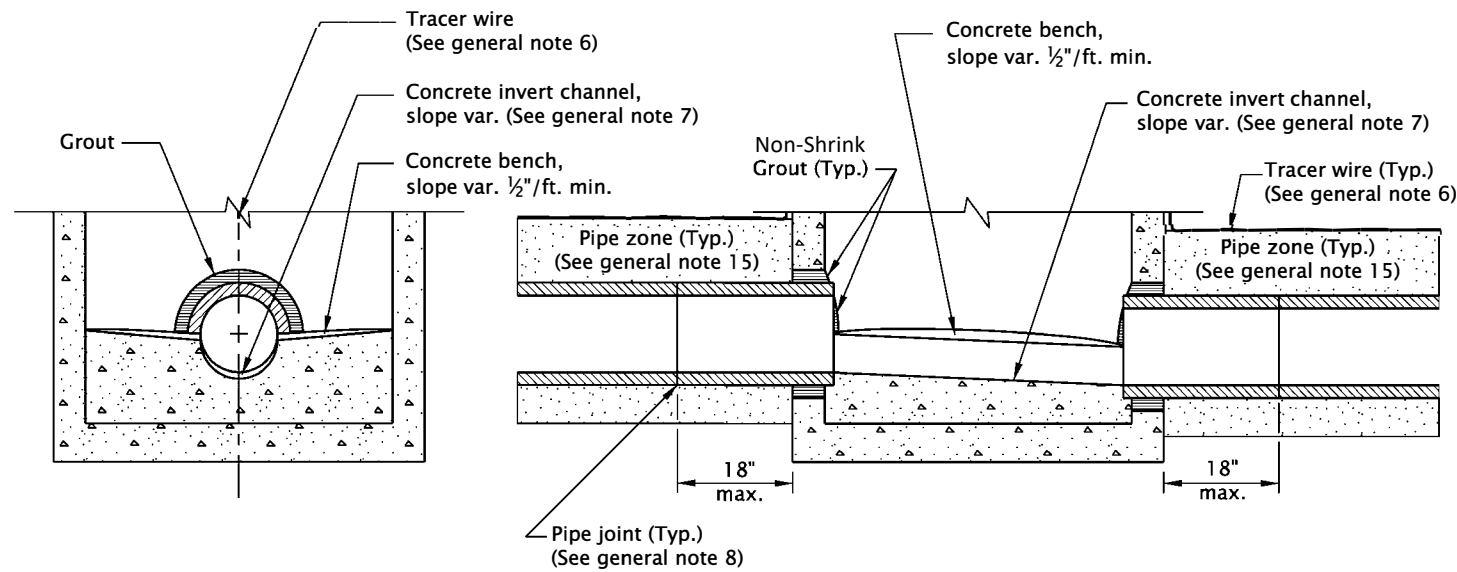
DATE	REVISION DESCRIPTION

The selection and use of this Standard Drawing, while designed in accordance with generally accepted engineering principles and practices, is the sole responsibility of the user and should not be used without consulting a Registered Professional Engineer.

RD344

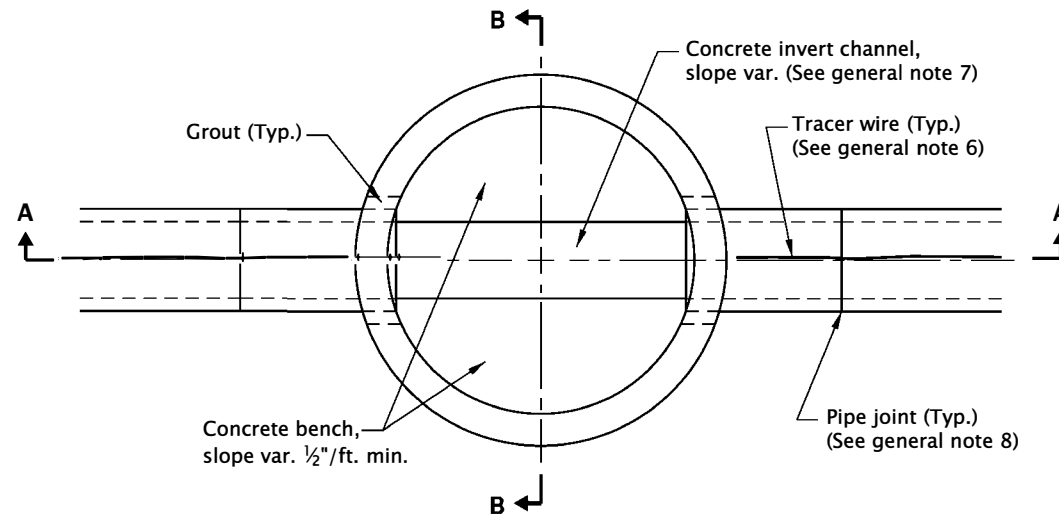
rd345.dgn 20-JUL-2020

RD345



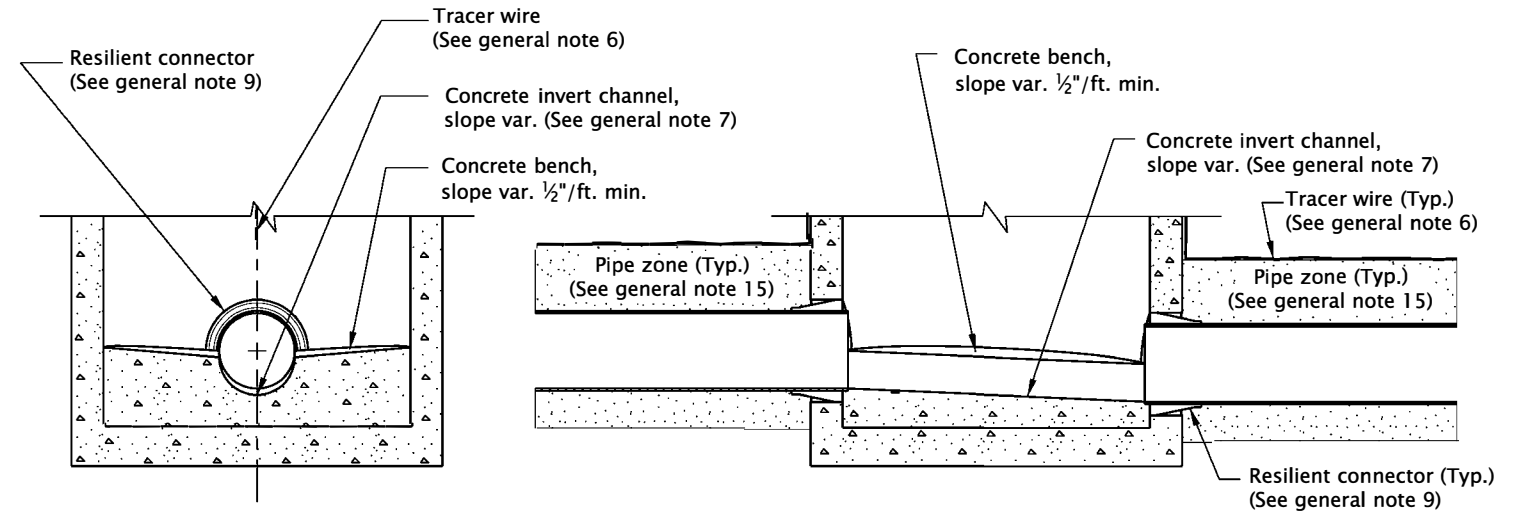
SECTION B-B

SECTION A-A



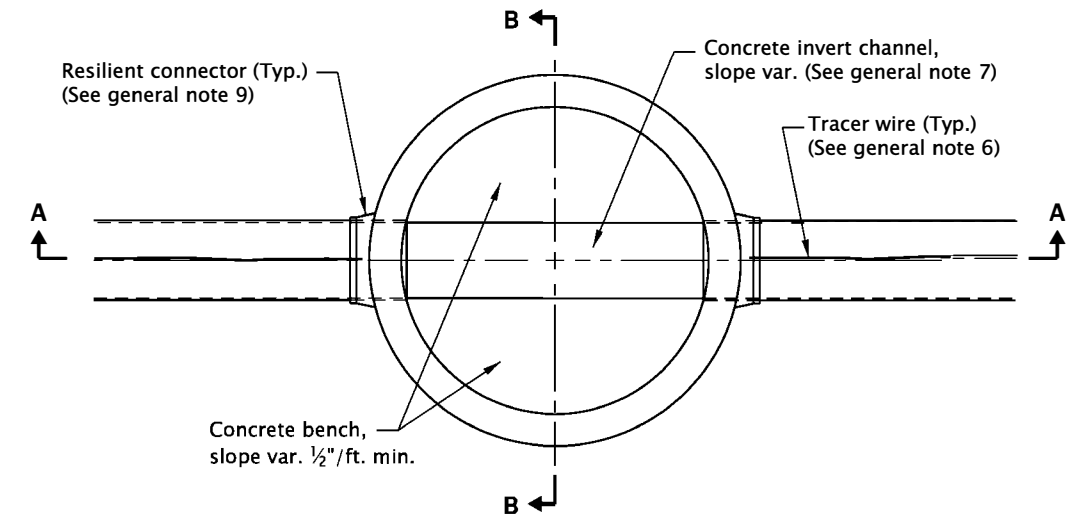
PLAN

CONNECTION OF RIGID PIPE TO MANHOLE



SECTION B-B

SECTION A-A



PLAN

CONNECTION OF FLEXIBLE PIPE TO MANHOLE

GENERAL NOTES FOR ALL DETAILS ON THIS SHEET:

1. All precast sections shall conform to requirements of ASTM C478.
2. Manhole base sections may be precast or cast-in-place.
3. All concrete shall be commercial grade concrete.
4. Location, elevation, diameter, slope, and number of pipe(s) varies, see project plans.
5. Max. pipe diameter varies with pipe material.
6. All connecting pipes shall have a tracer wire, or approved alternate. See Std. Dwg. RD336 for tracer wire details.
7. Invert channels shall be constructed to provide smooth slopes and radii to outlet pipe.

8. When flexible pipe is used, install resilient connectors conforming to requirements of ASTM C923.
9. See Std. Dwgs. RD335, RD336, and RD338 for details not shown.
10. See Std. Dwg. RD336 for manhole steps details.
11. See Std. Dwg. RD342 for shallow manholes.
12. See Std. Dwg. RD344 for manhole base section.
13. See Std. Dwg. RD356 for manhole covers and frames, manhole adjustment rings, etc.
14. Pipe zone varies, see Std. Dwg. RD300.

CALC. BOOK NO. N/A

SDR DATE 14-JUL-2014

NOTE: All material and workmanship shall be in accordance with the current City of The Dalles Standard Specifications

CITY OF THE DALLES STANDARD DRAWINGS

PIPE TO MANHOLE CONNECTIONS

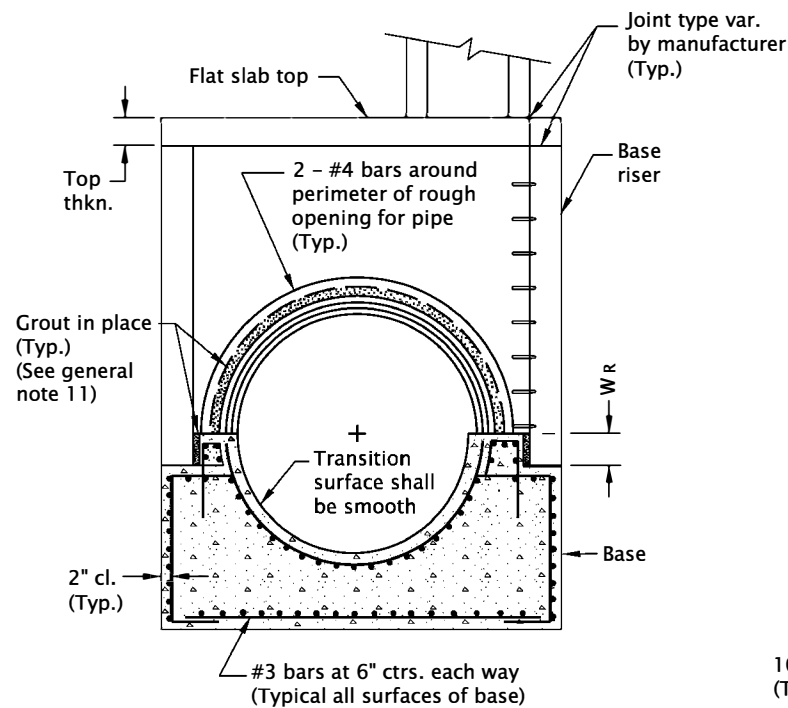
2025

DATE	REVISION	DESCRIPTION

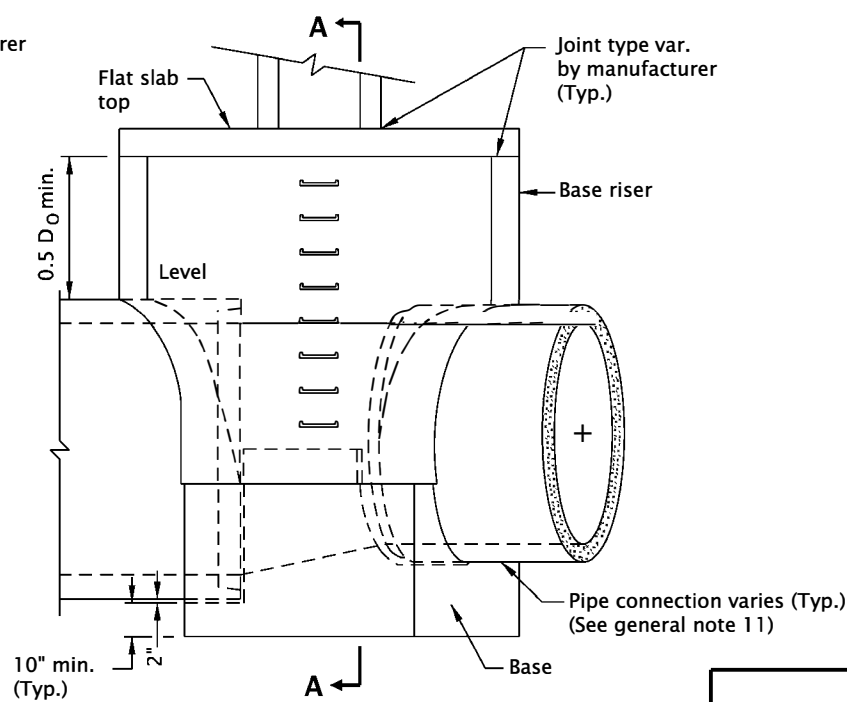
The selection and use of this Standard Drawing, while designed in accordance with generally accepted engineering principles and practices, is the sole responsibility of the user and should not be used without consulting a Registered Professional Engineer.

rd346.dgn 20-JUL-2020

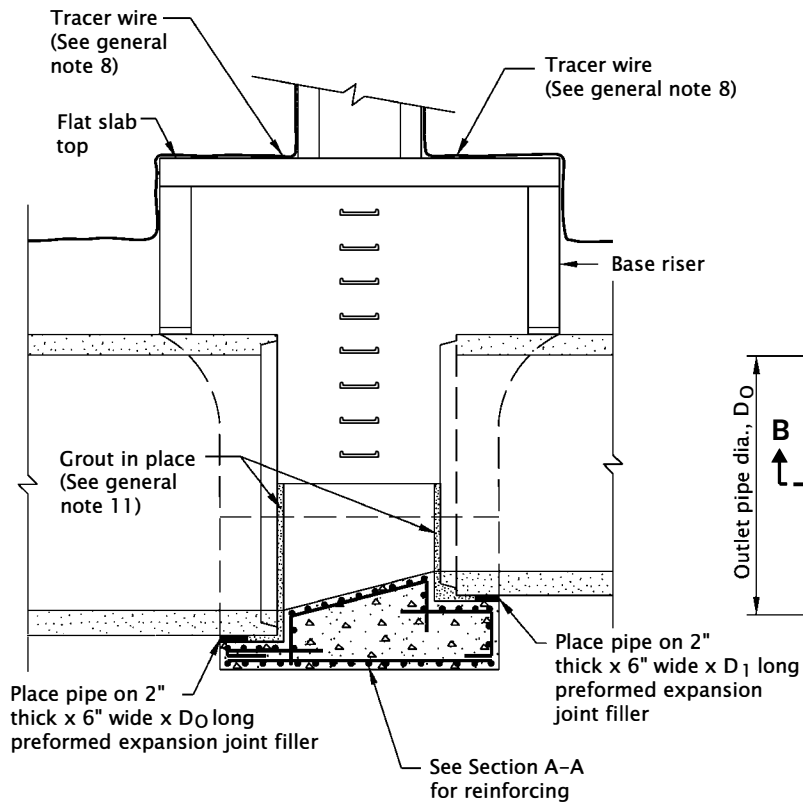
RD346



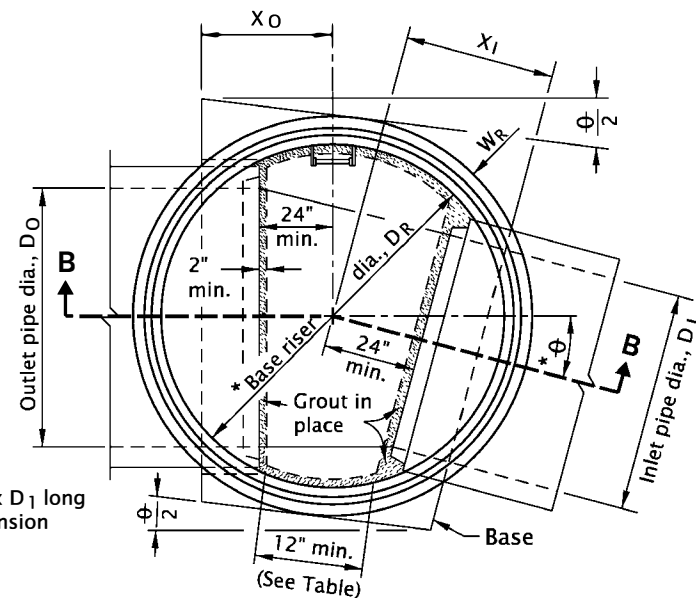
SECTION A-A



MANHOLE BASE ELEVATION



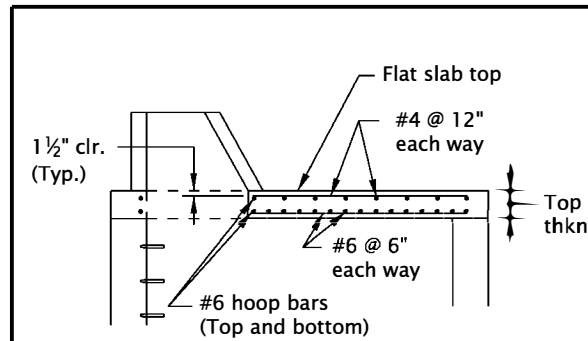
**DEVELOPED SECTION B-B
ALONG PIPE CENTERLINE**



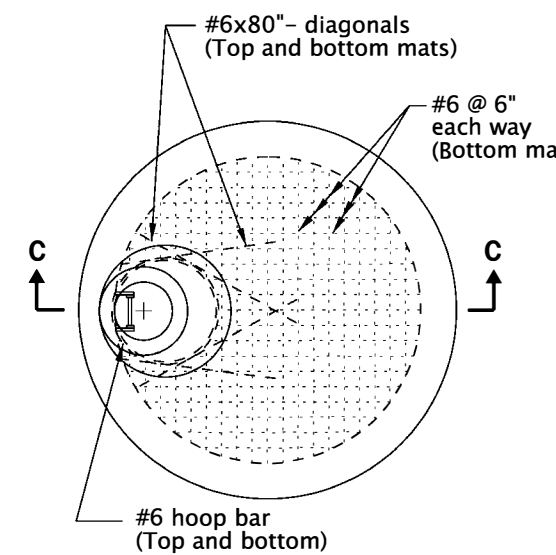
MANHOLE BASE PLAN

Dia. of largest pipe in manhole (Inch)	* Θ max when $D_1 = D_0$	* Base Riser			Base X_0 $X_1 = X_0$ when $D_1 = D_0$ (Feet)	Base X_1 when $D_1 < D_0$		
		DR (Inch)	WR (Inch)	Top Thkn. (Inch)		$D_1 = (D_0 - 6")$ (Feet)	$D_1 = (D_0 - 12")$ (Feet)	$D_1 = (D_0 - 18")$ (Feet)
30"	75°	60"	6"	10"	2.42	2.63	2.75	2.89
36"	67°	72"	7"	10"	2.75	2.97	3.15	3.29
42"	60°	72"	7"	10"	2.75	2.97	3.15	3.29
48"	54°	84"	8"	10"	3.02	3.27	3.48	3.66
54"	49°	84"	8"	10"	3.02	3.27	3.48	3.66
60"	45°	96"	9"	12"	3.25	3.54	3.78	3.99
66"	42°	96"	9"	12"	3.25	3.54	3.78	3.99
72"	39°	108"	10"	12"	3.48	3.79	4.06	4.29
78"	36°	108"	10"	12"	3.48	3.79	4.06	4.29
84"	34°	120"	11"	12"	3.69	4.03	4.32	4.57
90"	32°	120"	11"	12"	3.69	4.03	4.32	4.57
96"	30°	126"	11½"	12"	3.79	4.15	4.45	4.71

* A special design using a larger Base Riser diameter D_R may be required to obtain specified 12" min. dimension when Θ angle exceeds Θ max.



SECTION C-C



MANHOLE FLAT SLAB TOP PLAN
(Bottom reinf. mat shown)
(Manhole I.D. >4', <10' 6")

GENERAL NOTES FOR ALL DETAILS ON THIS SHEET:

- All concrete shall be Class 4000. All precast products shall conform to requirements of ASTM C478.
- All reinforcing steel shall conform to ASTM Specification A706 or AASHTO M31 (ASTM A615), Grade 60. The following splice lengths shall be used (unless shown otherwise):

Bar Size	4	5	6
Uncoated	16"	20"	24"
- All reinforcement shall be placed 2" clear of the nearest face of the concrete unless shown otherwise.
- Eccentric reducing cones or eccentric reducing flat slabs designed in accordance with AASHTO M199 shall be placed on top of the base riser as required by the contract plans. Eccentric reducing flat slabs shall be designed to support a load of 120 lb/ft in addition to the dead load of the slab, the risers above the slab, and the earth overburden above the slab.
- Base riser to be pre-cast unless otherwise shown on the plans.
- Cast-in-Place concrete, shown thus:
- See Std. Dwg. RD336 for manhole steps details, and flat slab top orientation.
- See Std. Dwg. RD336 for tracer wire details.
- See Std. Dwg. RD336 for manhole steps.
- Max. pipe diameter varies with pipe material.
- See Std. Dwg. RD345 for pipe to manhole connections.
- Location, elevation, diameter, slope, and number of pipe(s) varies, see project plans.

CALC. BOOK NO. N/A

SDR DATE 25-JUL-2017

NOTE: All material and workmanship shall be in accordance with the current City of The Dalles Standard Specifications

CITY OF THE DALLES STANDARD DRAWINGS

LARGE PRECAST MANHOLE

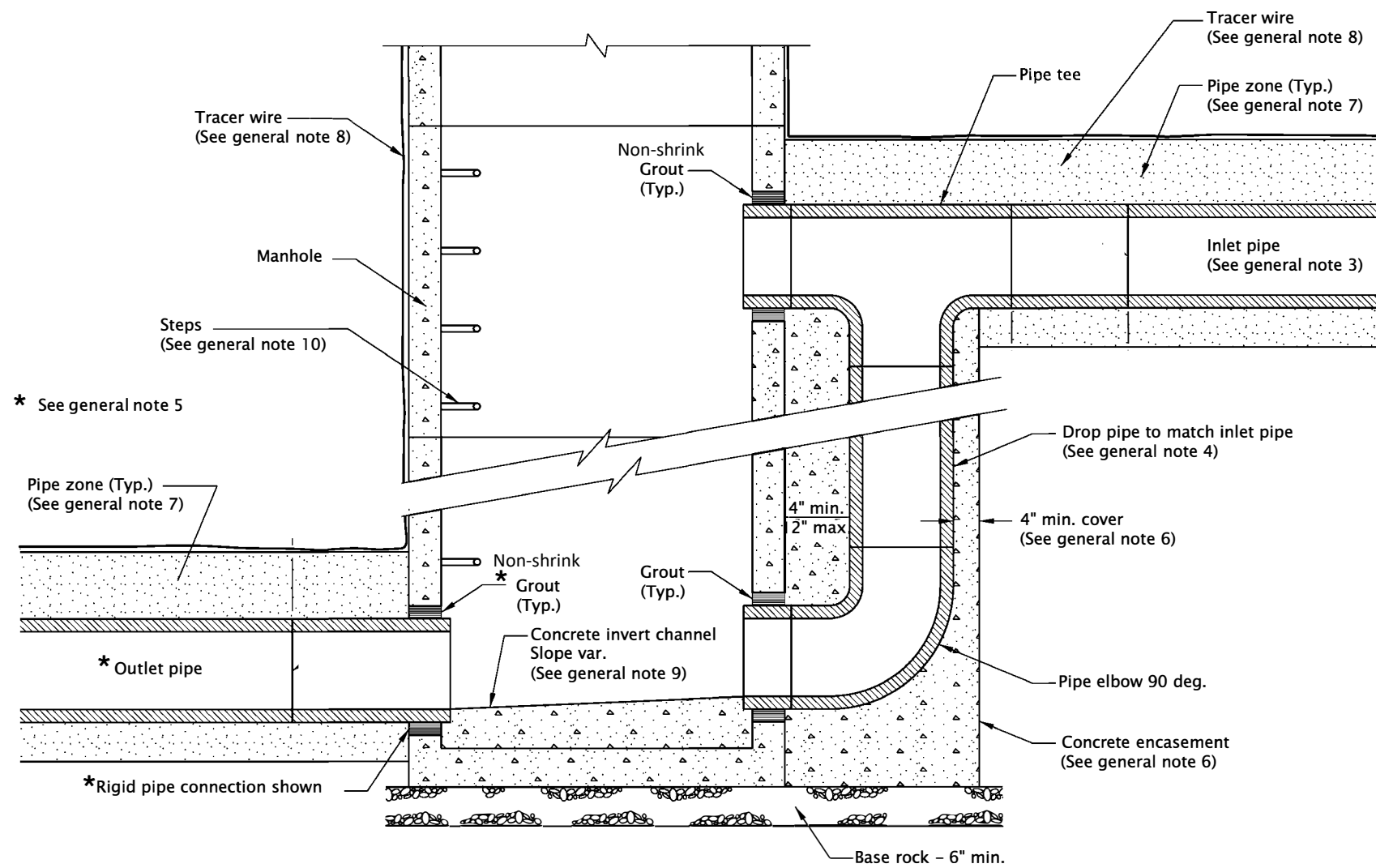
2025

DATE	REVISION	DESCRIPTION

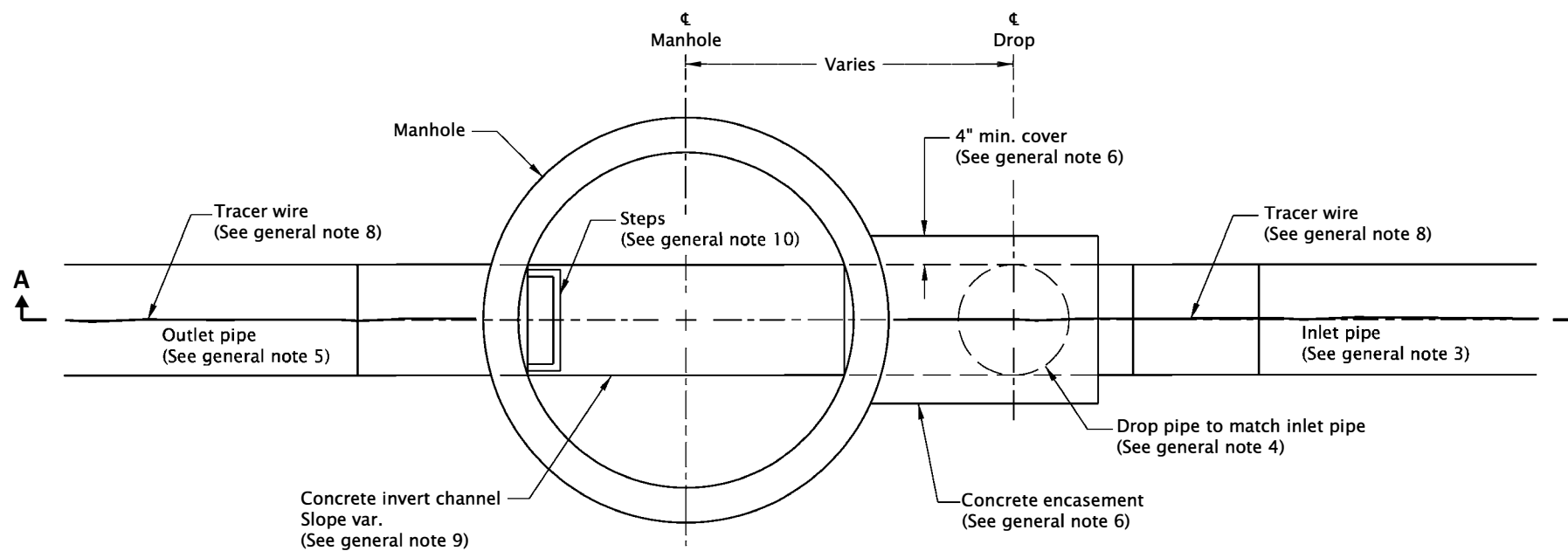
The selection and use of this Standard Drawing, while designed in accordance with generally accepted engineering principles and practices, is the sole responsibility of the user and should not be used without consulting a Registered Professional Engineer.

rd352.dgn 20-JUL-2020

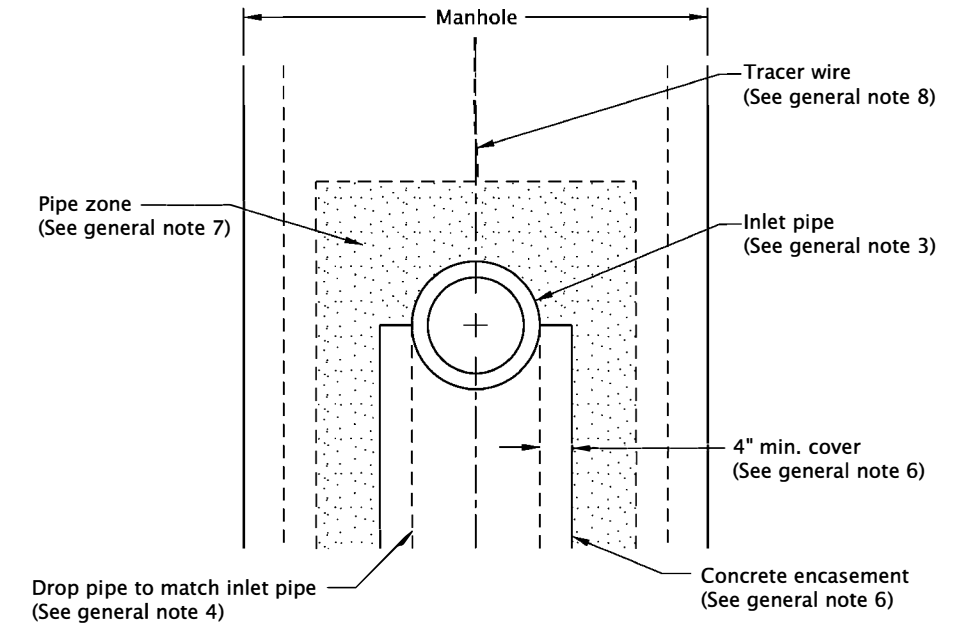
RD352



SECTION A-A



PLAN



END VIEW

GENERAL NOTES FOR ALL DETAILS ON THIS SHEET:

1. See appropriate manhole standard drawings for details not shown.
2. Location, elevation, diameter, slope, and number of pipe(s) varies, see project plans. Only 1 outside drop pipe allowed per manhole. See project plans for pipe material.
3. Inlet pipe may be rigid or flexible, maximum diameter 18".
4. Drop pipe, tee, and elbow to match inlet pipe.
5. Rigid pipe connection shown. Outlet pipe(s) may be rigid or flexible, see project plans. Max. outlet pipe diameter varies with pipe material. See Std. Dwg. RD345 for pipe to manhole connections.
6. Concrete encasement shall be commercial grade concrete. Provide 4" minimum cover over outer most parts of pipe and fittings.
7. Pipe zone varies, see Std. Dwg. RD300.
8. All connecting pipes shall have a tracer wire, or approved alternate. See Std. Dwg. RD336 for tracer wire details.
9. Invert channels shall be constructed to provide smooth slopes and radii to outlet pipe.
10. See Std. Dwg. RD336 for manhole steps details.

CALC. BOOK NO. N/A

SDR DATE 14-JUL-2014

NOTE: All material and workmanship shall be in accordance with the current City of The Dalles Standard Specifications

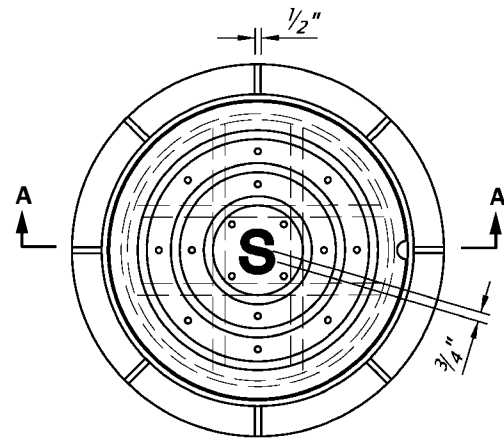
CITY OF THE DALLES STANDARD DRAWINGS

OUTSIDE DROP MANHOLES

2025

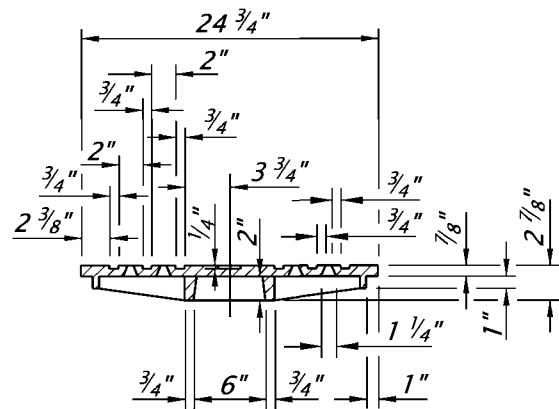
DATE	REVISION	DESCRIPTION

The selection and use of this Standard Drawing, while designed in accordance with generally accepted engineering principles and practices, is the sole responsibility of the user and should not be used without consulting a Registered Professional Engineer.

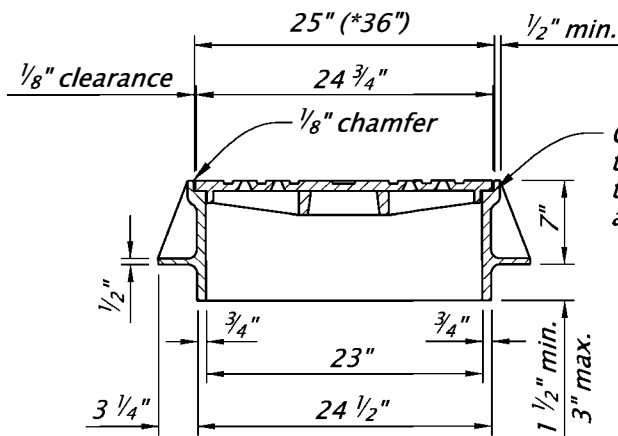


NOTE:
Coat outside of frame with asphalt where frame is to be placed in concrete, pavement, concrete gutter or walk.

PLAN



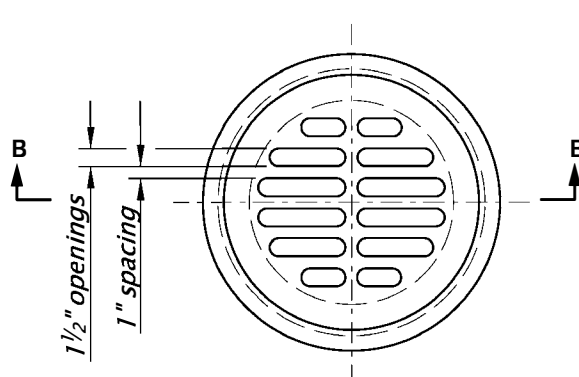
COVER SECTION A-A



FRAME SECTION A-A

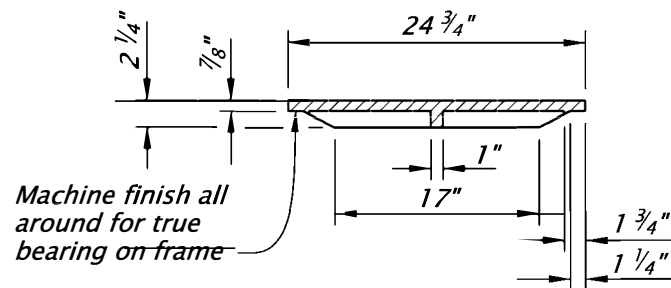
STANDARD MANHOLE COVER AND FRAME

*36 inch minimum diameter cover is required for manholes with depths of 20 feet or greater. See general note 4.



NOTE:
For use with standard manhole frame. See general note 7.

PLAN

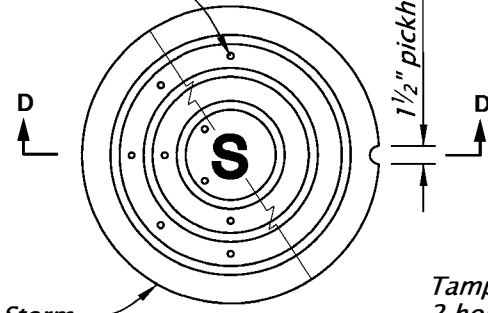


SECTION B-B

STANDARD MANHOLE GRATE

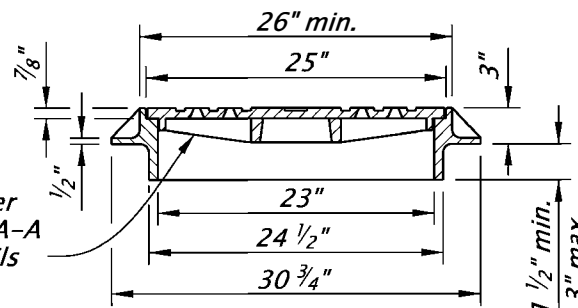
Machine finish all around for true bearing on frame

Sanitary, 2 holes maximum



PLAN

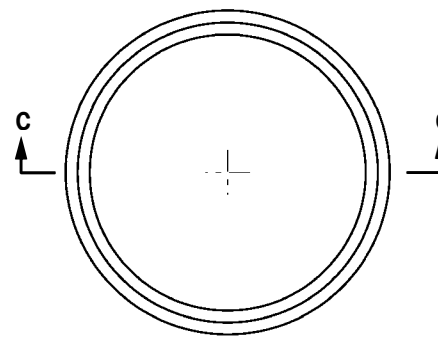
Tamperproof, 2 holes maximum for sanitary covers



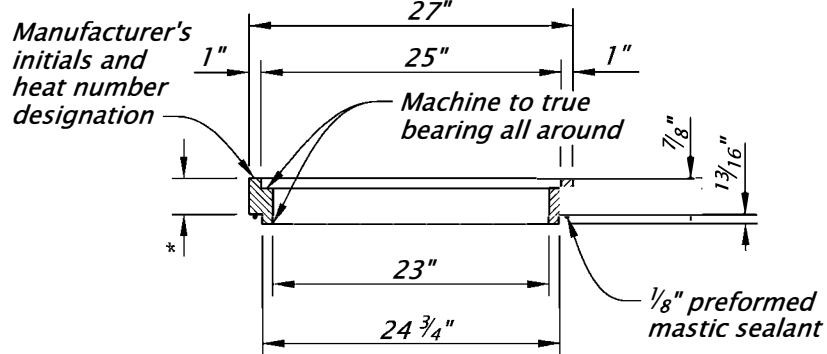
SECTION D-D

CAST IRON SUBURBAN MANHOLE COVER AND FRAME

For use on local streets only, as specified



PLAN

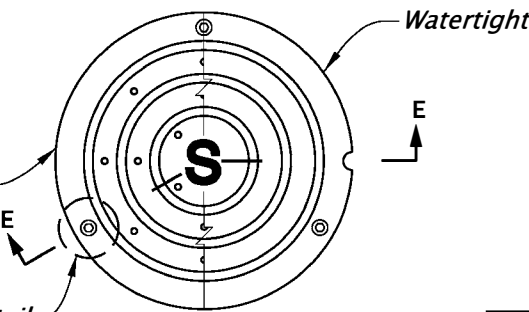


SECTION C-C

* Standard depths 1 1/2", 2", 2 1/2" and 3". Material to be grey cast iron ASTM A48, Class 35B. Tolerance on non-machined surfaces to be ±0.06". See general note 6

MANHOLE ADJUSTMENT RING

For use with Standard Manhole Frame

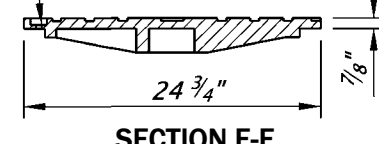


PLAN

CAST IRON TAMPERPROOF AND WATERTIGHT COVER

Frames available in standard or suburban pattern

See Bolt Down Detail



SECTION E-E

GENERAL NOTES FOR ALL DETAILS ON THIS SHEET:

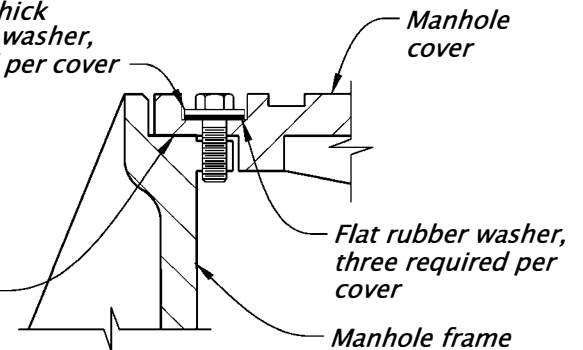
1. Tamperproof covers required on sanitary or storm drain manhole where located in pedestrian ways or easement areas. Covers for sanitary manholes shall have two holes maximum.
2. Watertight covers required if located where cover may be submerged (no holes).
3. Covers and frames shall be stamped with manufacturer's initials, heat number and point of origin.
4. See Std. Dwg. RD336 for manhole steps.
5. See Std. Dwg. RD360 for manhole frame adjustment.
6. See ODOT's QPL for alternate manhole adjustment rings.
7. Manhole grate allowed only in locations not subject to bicycle or pedestrian use.
8. See ODOT's QPL for alternate bolt-down products.

1 1/4" OD x 1/8" thick stainless steel washer, three required per cover

1/4" neoprene gasket, omit for tamperproof cover

Flat rubber washer, three required per cover

NOTE:
Three required, equally spaced, 1/2"x1 1/2" pentagonal or hexagonal head, bronze or stainless steel. Install frame so that one bolt boss is located over the manhole steps. See general note 8



BOLT DOWN DETAIL

For tamperproof and watertight covers

The selection and use of this Standard Drawing, while designed in accordance with generally accepted engineering principles and practices, is the sole responsibility of the user and should not be used without first consulting a Registered Professional Engineer.

All materials shall be in accordance with the current City of The Dalles Standard Specifications.

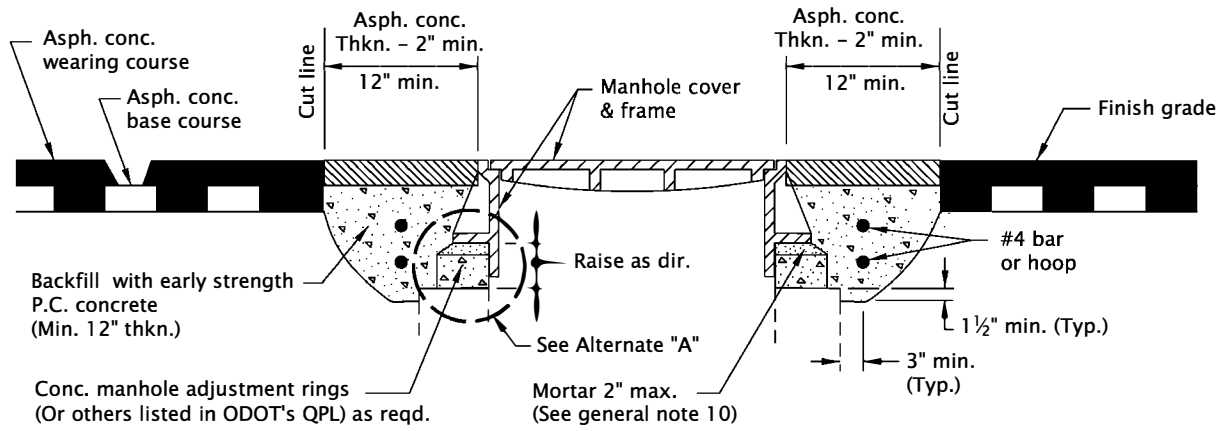
CITY OF THE DALLES STANDARD DRAWINGS

MANHOLE COVERS AND FRAMES

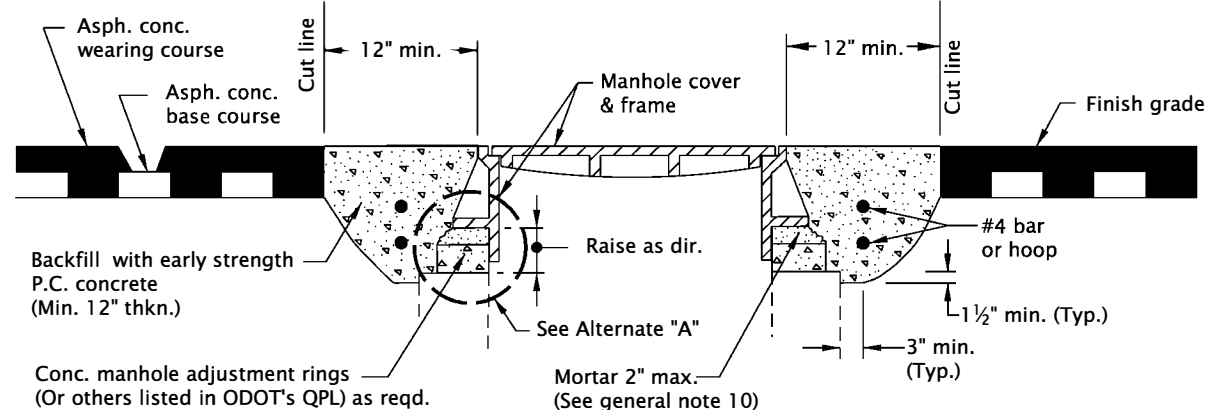
2025

DATE	REVISION	DESCRIPTION
07-2022	REVISED DETAILS AND NOTES	
CALC. BOOK NO.	N/A	SDR DATE
		21-JUN-2019

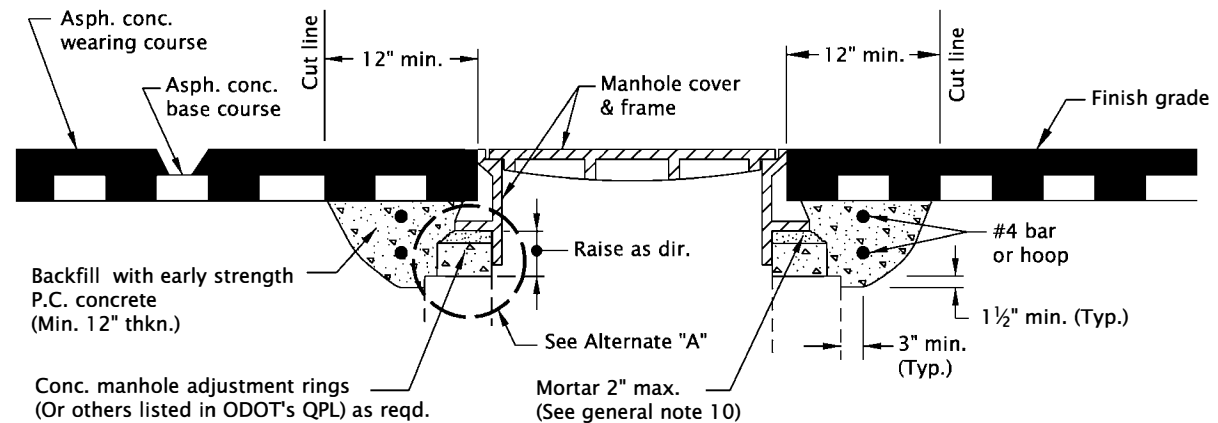
RD356



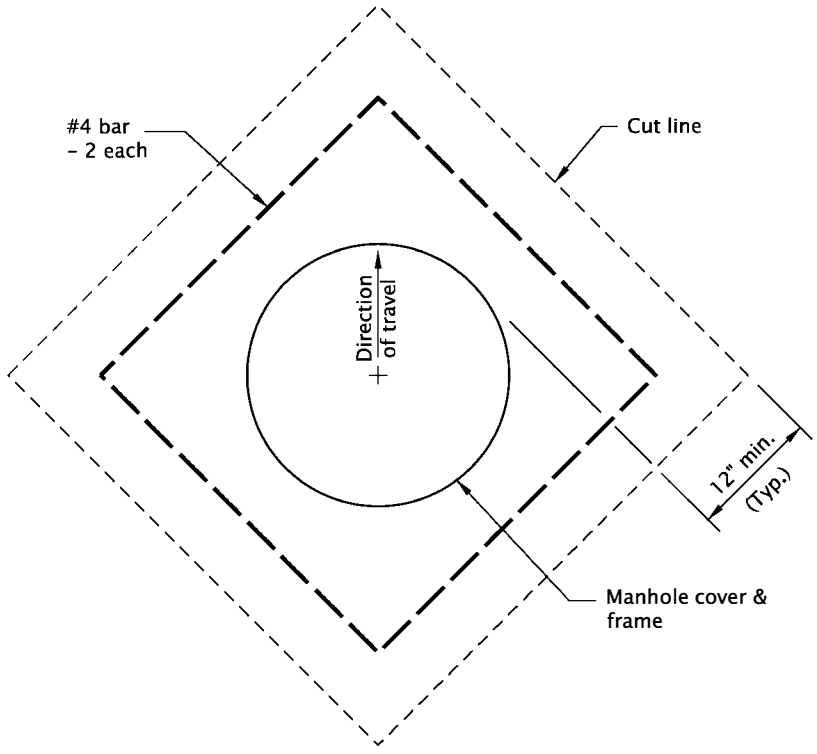
METHOD "A"



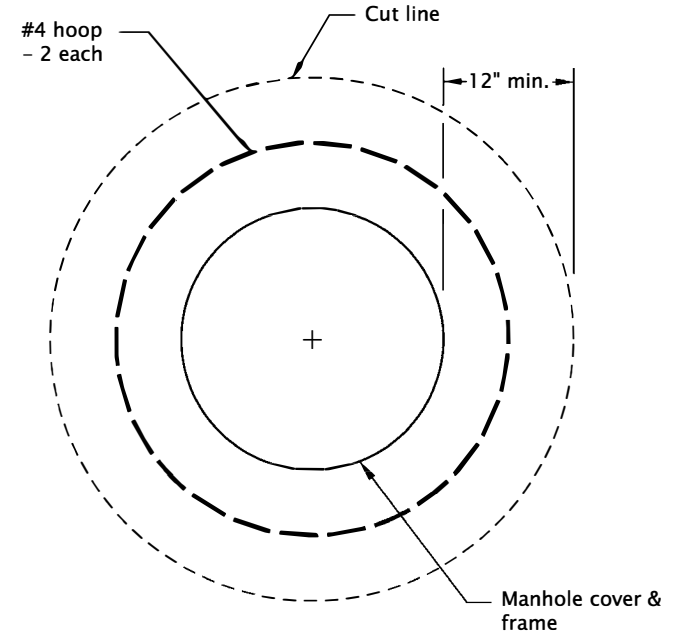
METHOD "B"



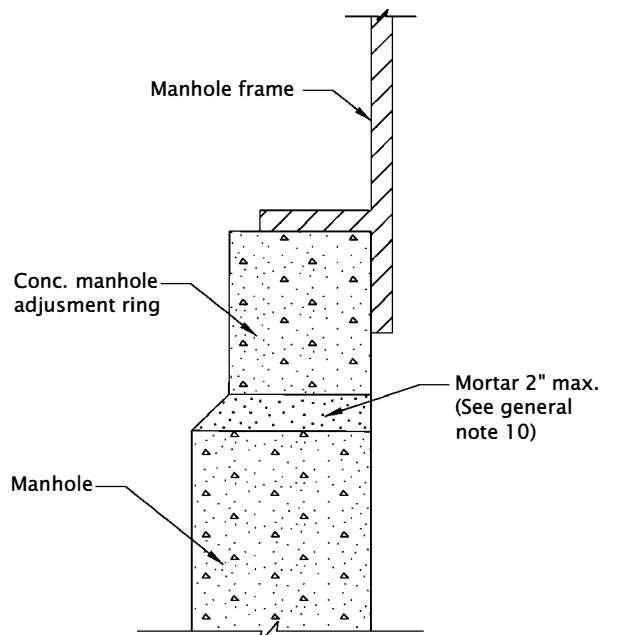
METHOD "C"



PLAN SQUARE CUT



PLAN CIRCULAR CUT



ALTERNATE "A"

GENERAL NOTES FOR ALL DETAILS ON THIS SHEET:

1. Cover manhole with building paper and const. asp. conc. base course and wearing courses.
2. Saw cut square or circular excavation around manhole 12" min. from manhole frame.
3. Raise manhole cover and frame to finish grade by installing conc. manhole adjustment rings and leveling mortar, as shown.
4. Backfill with early strength Portland Cement Concrete. All concrete shall be commercial grade concrete.
5. Protect from traffic loading until conc. has cured to 3000 psi.
6. Apply tack coat to edges of existing pavement before installing patch.
7. Finish joint with asphalt seal and sand.
8. See Std. Dwg. RD336 for manhole steps details.
9. See appropriate manhole standard drawings for details not shown.
10. Use epoxy for synthetic grade rings.
11. See Std. Dwg. RD336 for tracer wire details.
12. See Std. Dwg. RD356 for manhole covers and frames.

CALC. BOOK NO. <u>N/A</u>	SDR DATE <u>21-JUL-2015</u>
---------------------------	-----------------------------

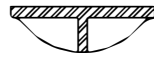
NOTE: All material and workmanship shall be in accordance with the current City of The Dalles Standard Specifications

CITY OF THE DALLES STANDARD DRAWINGS	
MANHOLE FRAME ADJUSTMENT	
2025	
DATE	REVISION DESCRIPTION

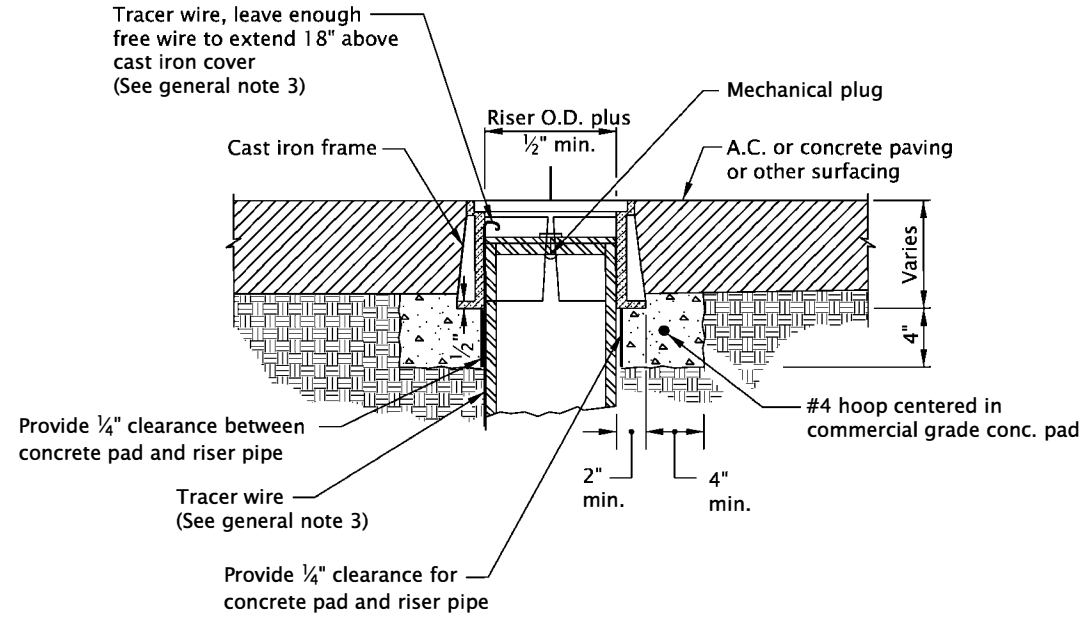
The selection and use of this Standard Drawing, while designed in accordance with generally accepted engineering principles and practices, is the sole responsibility of the user and should not be used without consulting a Registered Professional Engineer.

rd362.dgn 20-JUL-2020

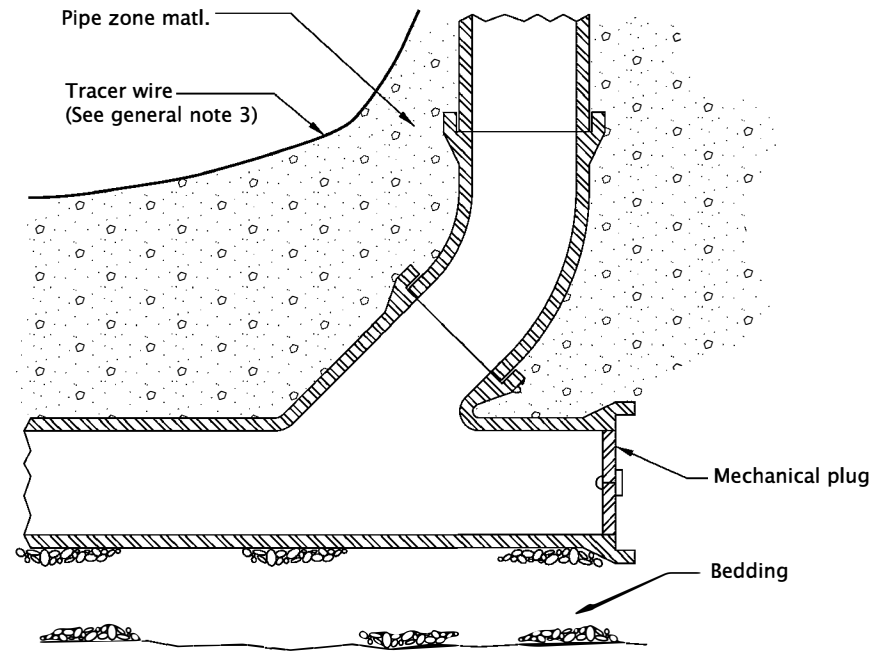
RD362



CAST IRON COVER



CAST IRON FRAME



CLEANOUT

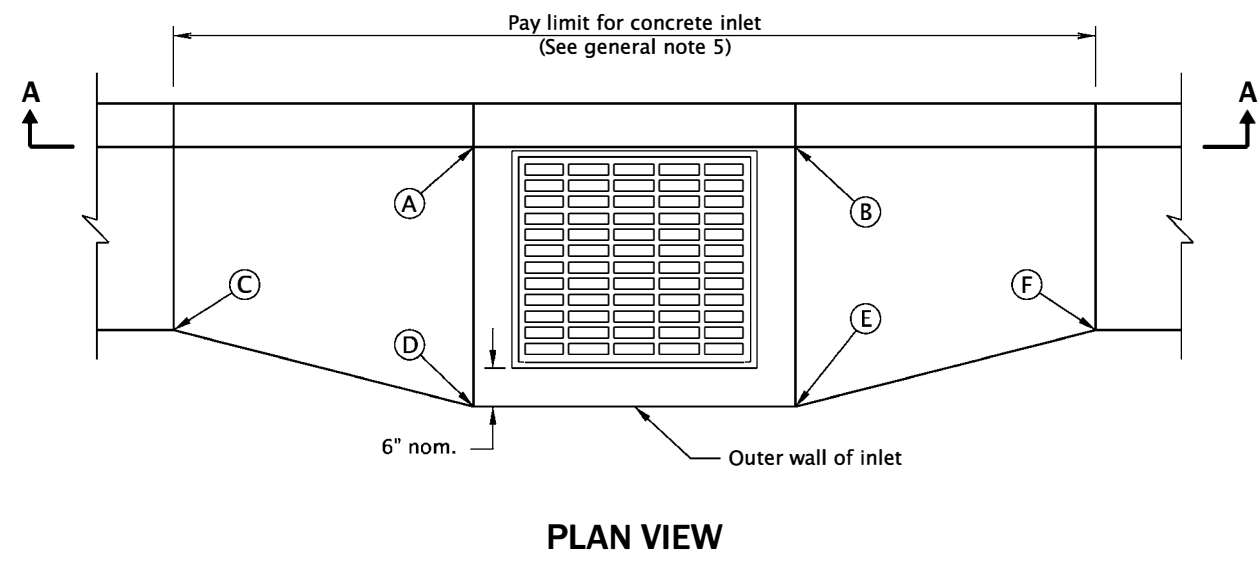
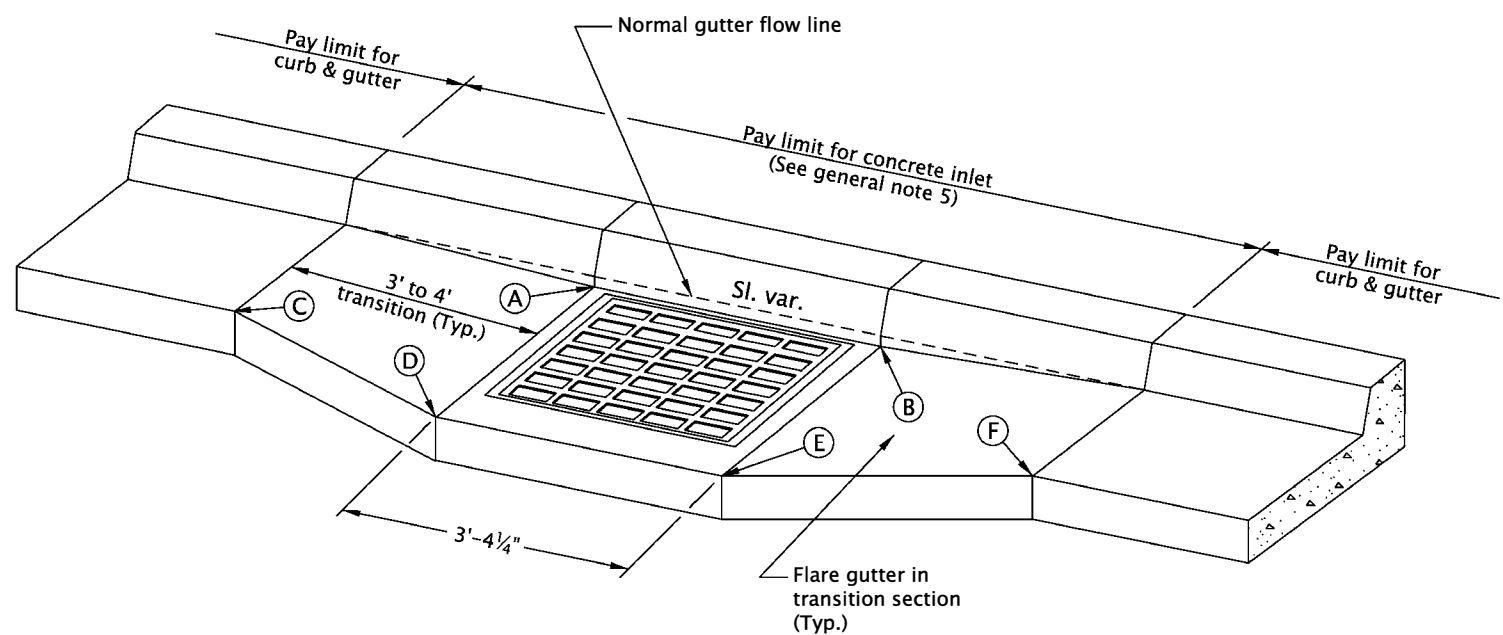
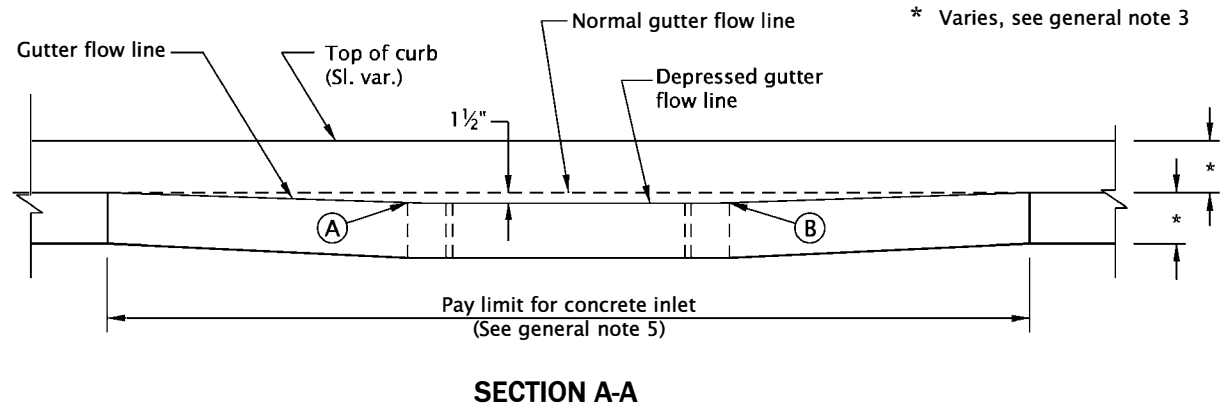
FRAMES AND COVERS

4" SERVICE CLEANOUT: OLYMPIC FOUNDRY 041814 FRAME, or approved equal
 OLYMPIC FOUNDRY 18-5122 COVER, or approved equal
 8" OR LARGER CLEANOUT: OLYMPIC FOUNDRY M1018DT FRAME AND COVER, or approved equal

CALC. BOOK NO. <u>N/A</u>	SDR DATE <u>14-JUL-2014</u>
<p><i>The selection and use of this Standard Drawing, while designed in accordance with generally accepted engineering principles and practices, is the sole responsibility of the user and should not be used without consulting a Registered Professional Engineer.</i></p>	NOTE: All material and workmanship shall be in accordance with the current City of The Dalles Standard Specifications
	CITY OF THE DALLES STANDARD DRAWINGS
	SANITARY CLEANOUT
	2025
	DATE REVISION DESCRIPTION

rd363.dgn 20-JUL-2020

- NOTES:
1. Provide 1 1/2" local depression at points A & B.
 2. Match normal pvmt. grade at points C, D, E & F.
 3. Vary transition section slopes to match above points.



- GENERAL NOTES FOR ALL DETAILS ON THIS SHEET:
1. For inlet details, see appropriate inlet standard drawing(s).
 2. For frame and grate details, see Std. Dwg. RD365.
 3. For curb details, see Std. Dwgs. RD700 & RD701.
 4. All concrete shall be commercial grade concrete.
 5. Pay limit for inlet is expanded when curb and gutter are monolithic.

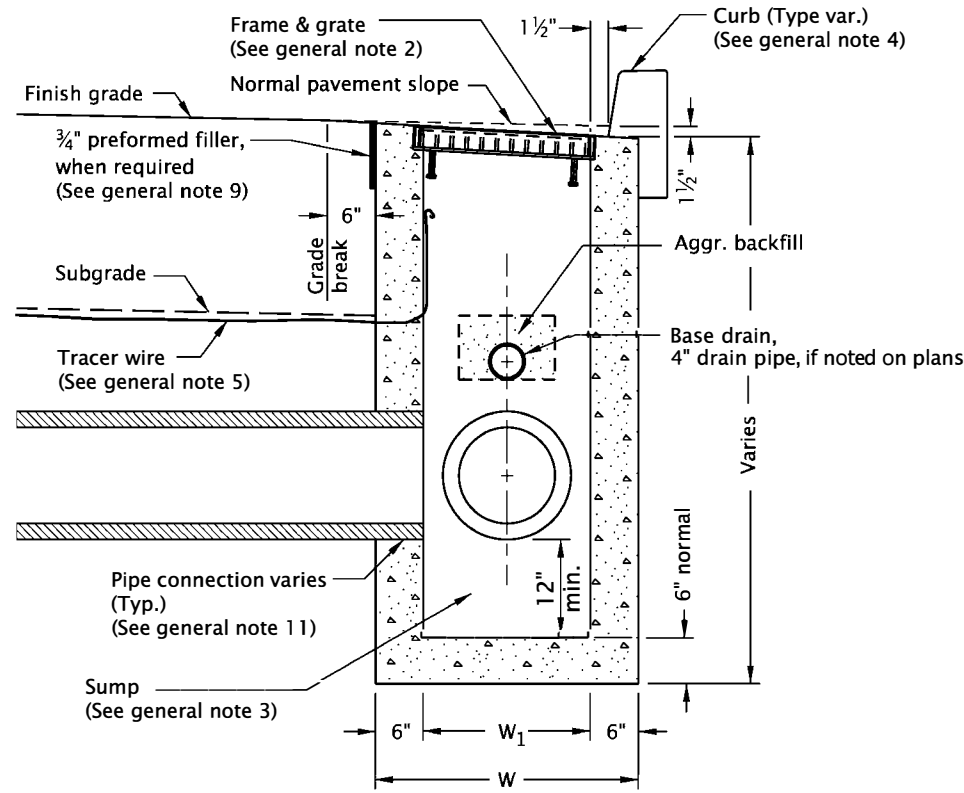
CALC. BOOK NO. N/A SDR DATE 21-JUL-2015

NOTE: All material and workmanship shall be in accordance with the current City of The Dalles Standard Specifications

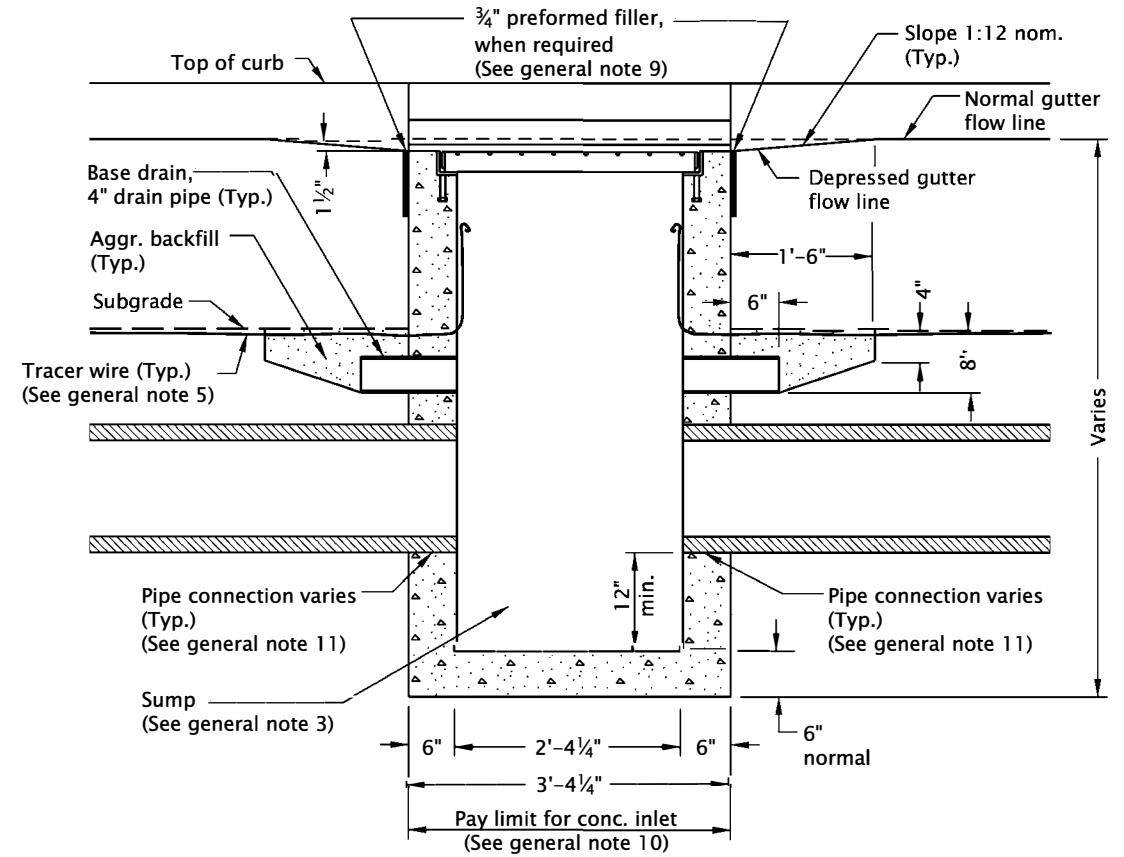
The selection and use of this Standard Drawing, while designed in accordance with generally accepted engineering principles and practices, is the sole responsibility of the user and should not be used without consulting a Registered Professional Engineer.

CITY OF THE DALLES STANDARD DRAWINGS	
GUTTER TRANSITION AT INLET	
2025	
DATE	REVISION DESCRIPTION

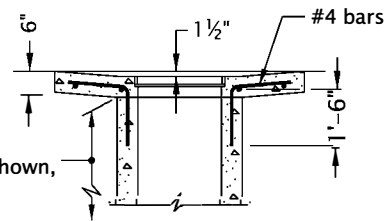
RD363



SECTION B - B



SECTION A - A

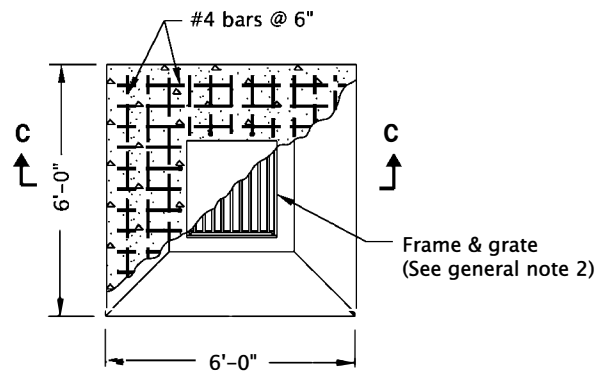


SECTION C - C

For details not shown, see inlet G-2

NOTE:

All reinforcement to be placed 2" clear of nearest face of concrete unless shown or noted otherwise

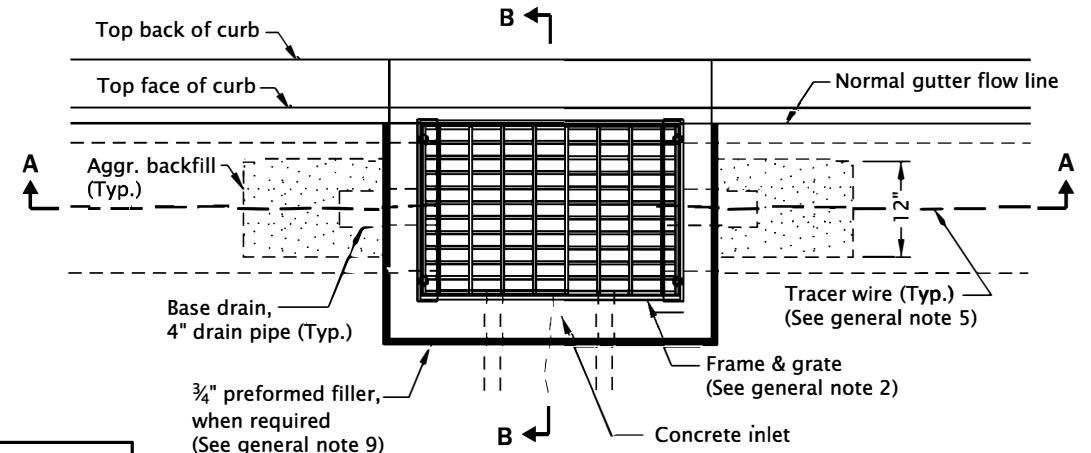


PLAN
TYPE G-2MA

TABLE A		
INLET TYPE	W	W ₁
G-1	2'-8 ⁷ / ₈ "	1'-8 ⁷ / ₈ "
G-2, G-2M, G-2MA	3'-3 ³ / ₈ "	2'-3 ³ / ₈ "

GENERAL NOTES FOR ALL DETAILS ON THIS SHEET:

- Where precast inlets are used as an alternate to cast-in-place inlets, a 4" compacted leveling bed of 3/4"-0 crushed aggregate shall be provided. All precast inlets shall conform to requirements of ASTM C913.
- Graphics show G-1 inlet with Type 2 grate. See Table A for inlet dimensions.
Type 1 grate allowed only in locations not subject to bicycle or pedestrian use.
For frame and grate details, see Std. Dwg. RD365.
- Provide 18" sump unless otherwise approved by City Engineer
- For curb details, see Std. Dwgs. RD700 & RD701.
- See Std. Dwg. RD336 for tracer wire details, or approved alternate.
- Max. pipe diameter varies with pipe material.
- Location, elevation, diameter, slope, and number of pipe(s) varies, see project plans.
- All concrete shall be commercial grade concrete.
- 3/4" preformed filler (in concrete pavement or gutter only) to extend through thickness of concrete.
- See Std. Dwg. RD363 for gutter transition section, when curb and gutter are required.
- See Std. Dwg. RD339 for pipe to structure connections.



PLAN
TYPE G-1, G-2, G-2M

CALC. BOOK NO. N/A

SDR DATE

NOTE: All material and workmanship shall be in accordance with the current City of The Dalles Standard Specifications

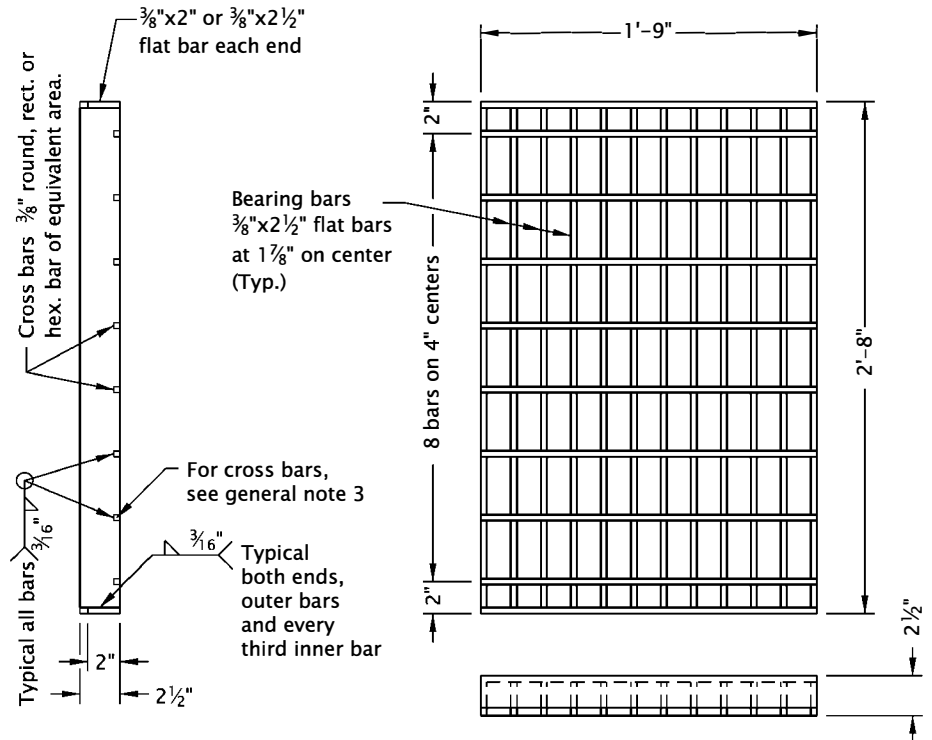
CITY OF THE DALLES STANDARD DRAWINGS

CONCRETE INLETS
TYPE G-1, G-2, G-2M, & G-2MA

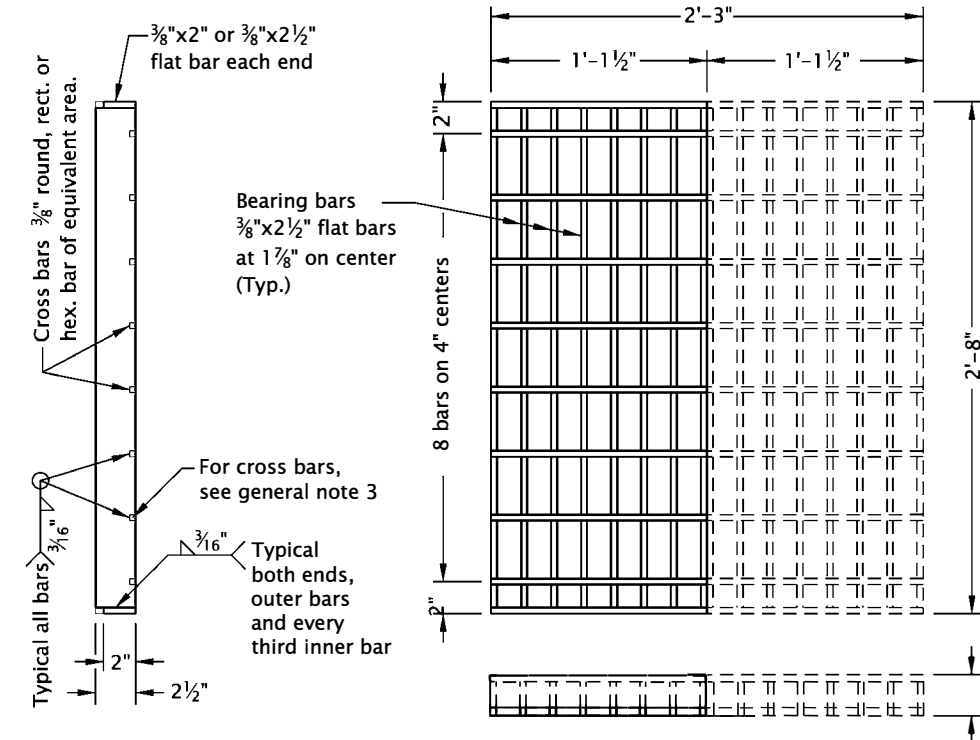
2025

DATE	REVISION DESCRIPTION

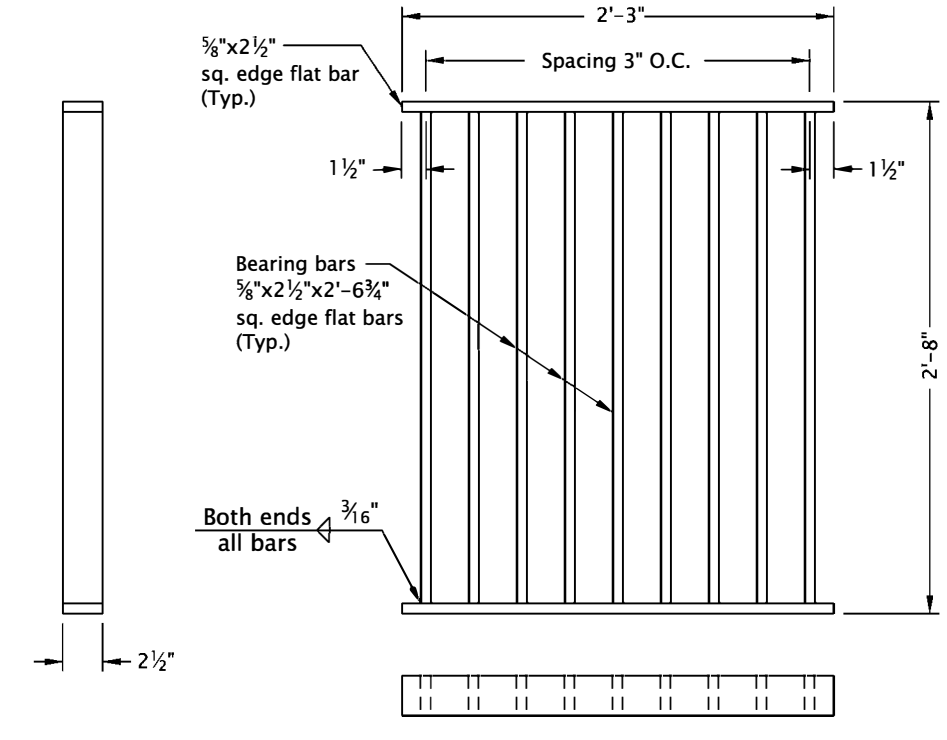
The selection and use of this Standard Drawing, while designed in accordance with generally accepted engineering principles and practices, is the sole responsibility of the user and should not be used without consulting a Registered Professional Engineer.



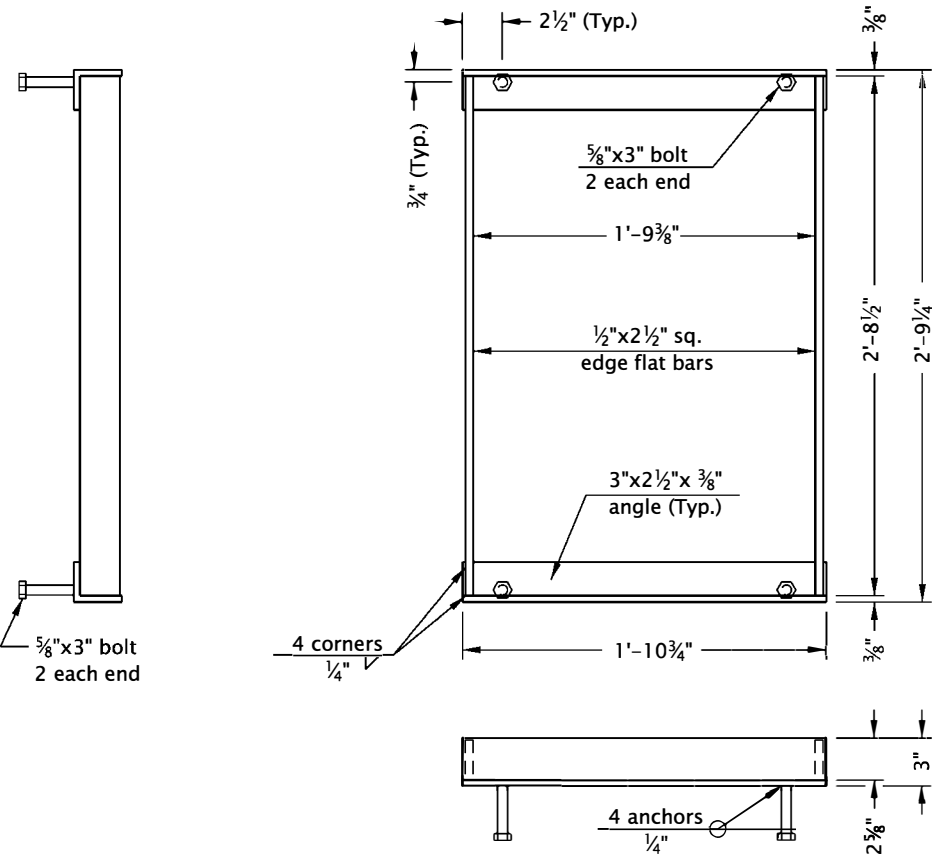
**G-1, CG-1 GRATE
(TYPE 2)**
(Bicycle-safe)



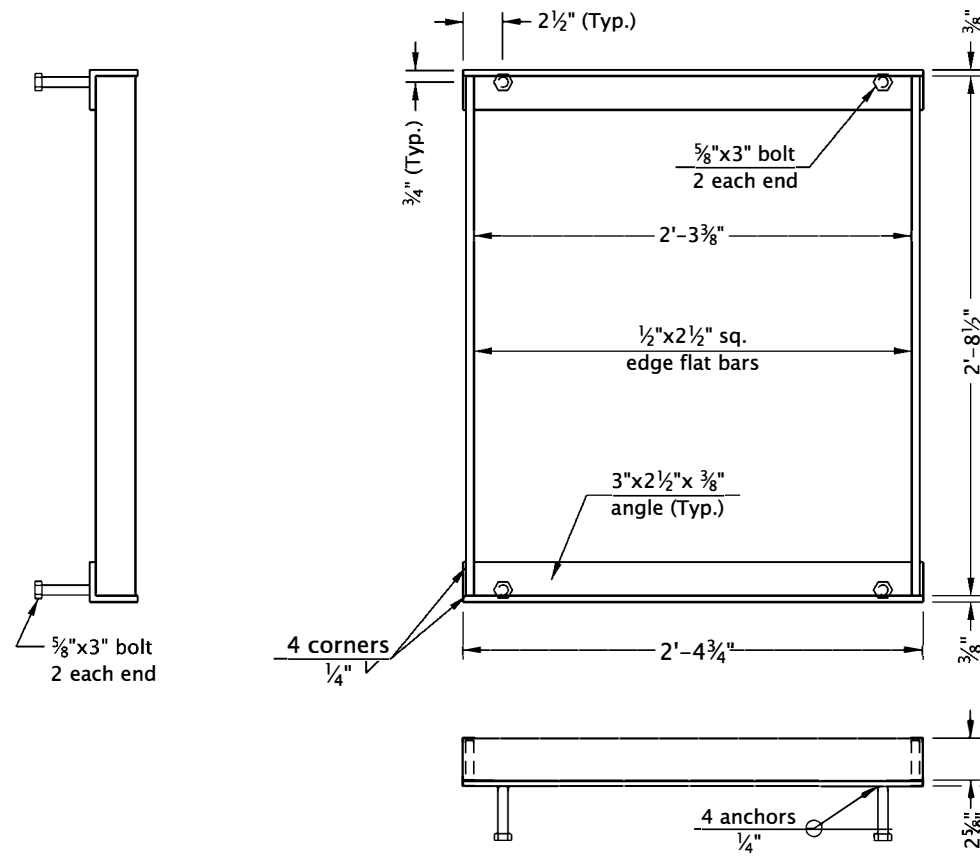
**G-2, G-2M, G-2MA, CG-2 GRATE
(TYPE 2)**
(Bicycle-safe)
(2 grates required per inlet, as shown)



**G-2, G-2M, G-2MA, CG-2 GRATE
(TYPE 1)**
(See general note 2)



G-1, CG-1 FRAME



G-2, G-2M, G-2MA, CG-2 FRAME

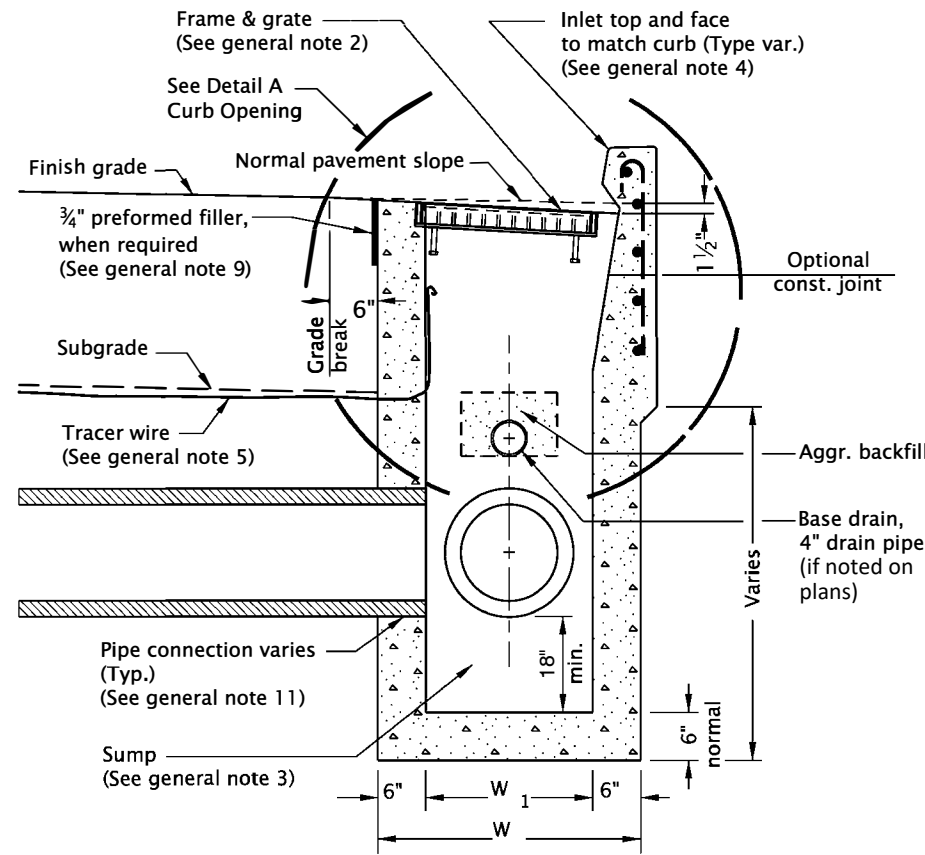
- GENERAL NOTES FOR ALL DETAILS ON THIS SHEET:
1. For inlet details, see appropriate inlet standard drawing(s).
 2. Type 1 grate allowed only in locations not subject to bicycle or pedestrian use.
 3. 3/8" cross bars shall be flush with the top of grate surface and may be fillet welded, resistance welded or electroforged to bearing bars.
 4. Hot dip galvanize after fabrication.
 5. Cast iron grate and frame are acceptable alternates. See ODOT's QPL.

CALC. BOOK NO. <u>N/A</u>	SDR DATE <u>14-JUL-2014</u>
NOTE: All material and workmanship shall be in accordance with the current City of The Dalles Standard Specifications	
CITY OF THE DALLES STANDARD DRAWINGS	
FRAMES & GRATES FOR CONCRETE INLETS	
2025	
DATE	REVISION DESCRIPTION

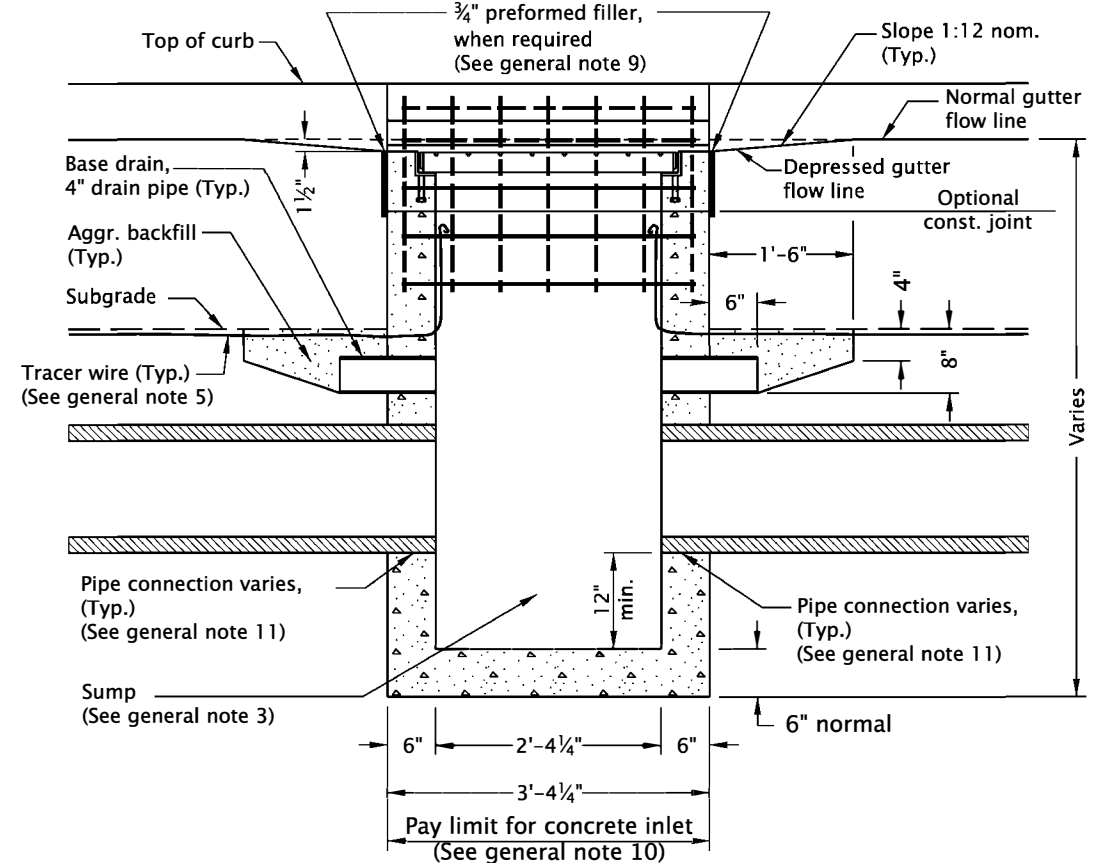
The selection and use of this Standard Drawing, while designed in accordance with generally accepted engineering principles and practices, is the sole responsibility of the user and should not be used without consulting a Registered Professional Engineer.

rd366.dgn 20-JUL-2020

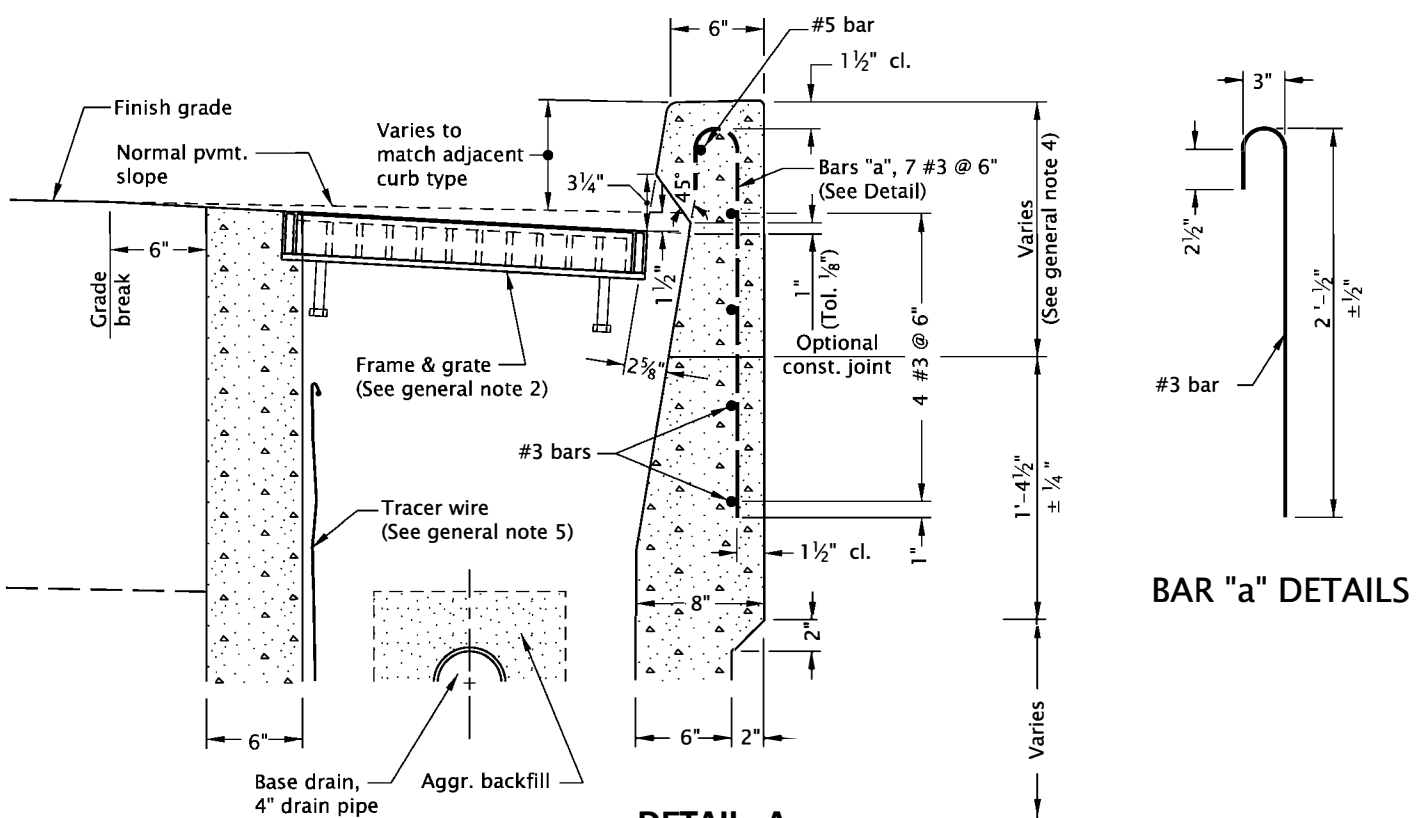
- GENERAL NOTES FOR ALL DETAILS ON THIS SHEET:**
- Where precast inlets are used as an alternate to cast-in-place inlets, a 4" compacted leveling bed of 3/4"-0 crushed aggregate shall be provided. All precast inlets shall conform to requirements of ASTM C913.
 - Graphics show CG-1 inlet with Type 2 grate. See Table A for inlet dimensions. Type 1 grate allowed only in locations not subject to bicycle or pedestrian use. For frame and grate details, see Std. Dwg. RD365.
 - Provide 18" sump unless otherwise approved by City Engineer.
 - For curb details, see Std. Dwgs. RD700 & RD701.
 - See Std. Dwg. RD336 for tracer wire details, or approved alternate.
 - Max. pipe diameter varies with pipe material.
 - Location, elevation, diameter, slope, and number of pipe(s) varies, see project plans.
 - All concrete shall be commercial grade concrete.
 - 3/4" preformed filler (in concrete pavement or gutter only) to extend through thickness of concrete.
 - See Std. Dwg. RD363 for gutter transition section, when curb and gutter are required. (Pay limit for inlet is expanded when curb and gutter are monolithic)
 - See Std. Dwg. RD339 for pipe to structure connections.



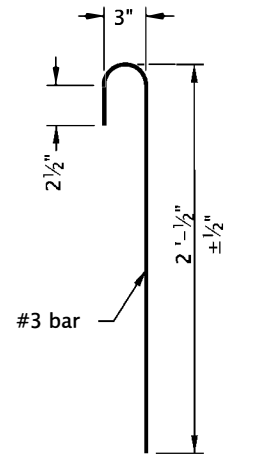
SECTION B - B



SECTION A - A



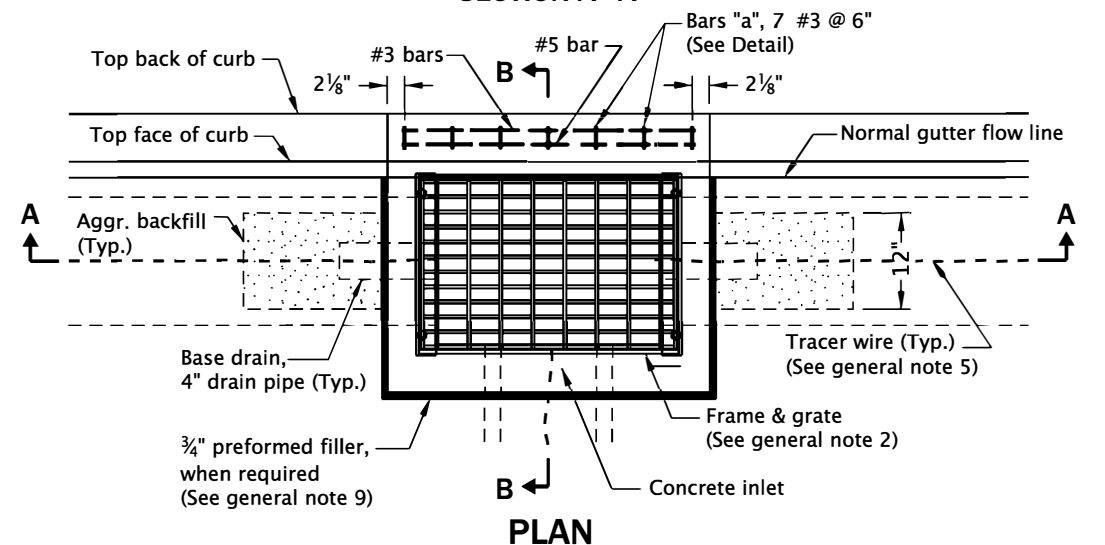
DETAIL A CURB OPENING



BAR "a" DETAILS

TABLE A		
INLET TYPE	W	W ₁
CG-1	2'-8 1/8"	1'-8 1/8"
CG-2	3'-3 3/8"	2'-3 3/8"

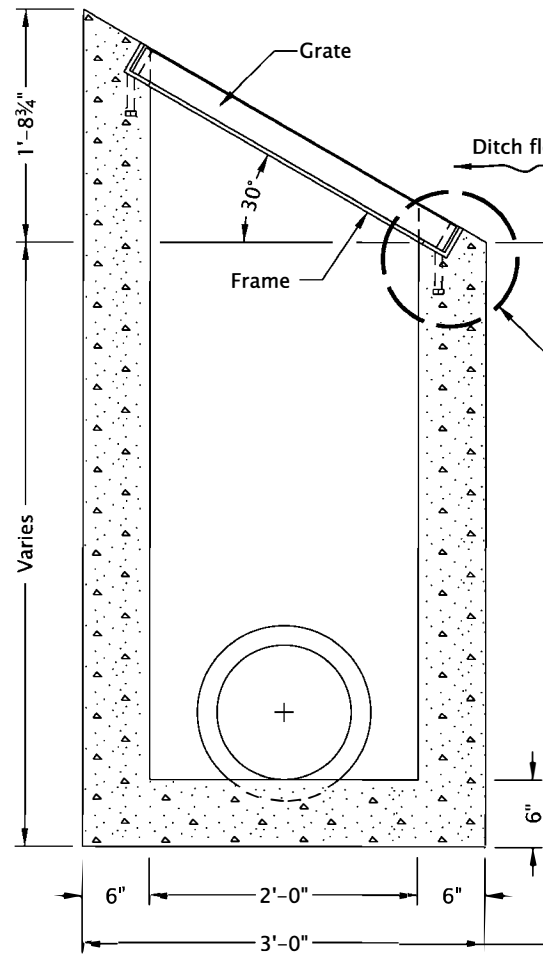
- NOTES:**
- #3 "a" bars to be placed during curb construction.
 - All bars to be placed 1 1/2" clear of nearest face of concrete unless shown or noted otherwise.
 - All bars shall be full length.



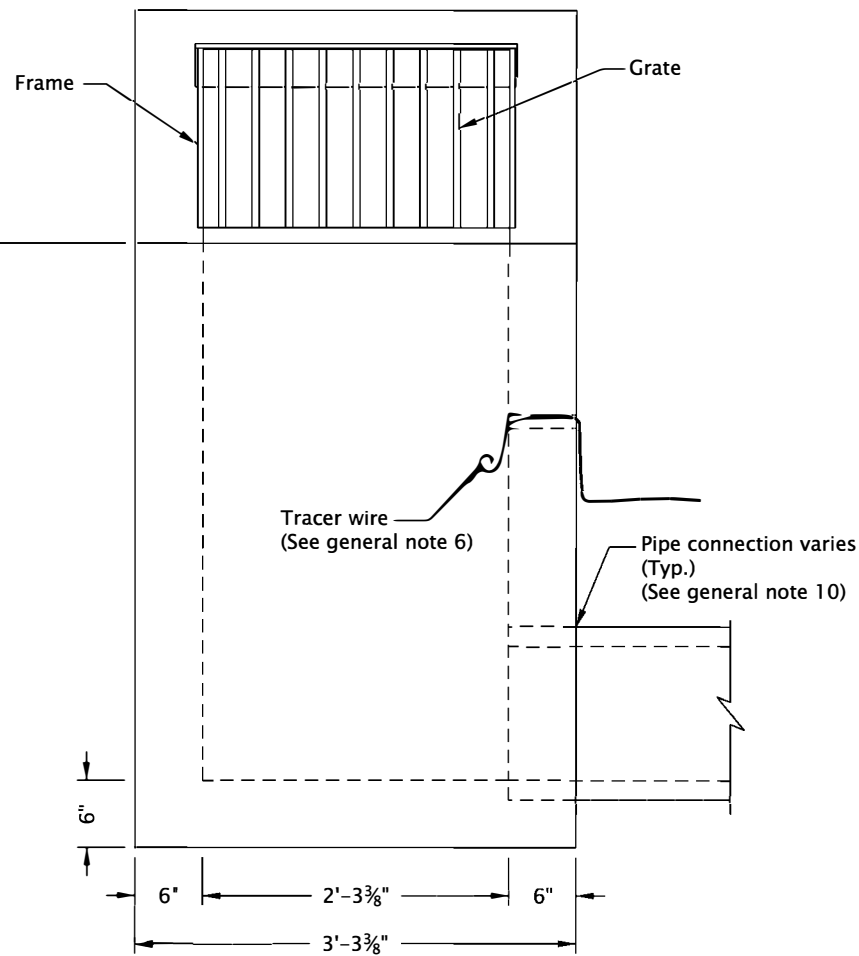
PLAN

<p>CALC. BOOK NO. <u>N/A</u></p> <p><i>The selection and use of this Standard Drawing, while designed in accordance with generally accepted engineering principles and practices, is the sole responsibility of the user and should not be used without consulting a Registered Professional Engineer.</i></p>	<p>SDR DATE <u>20-JUL-2020</u></p> <p>NOTE: All material and workmanship shall be in accordance with the current City of The Dalles Standard Specifications</p> <p>CITY OF THE DALLES STANDARD DRAWINGS</p> <p>CONCRETE INLETS</p> <p>TYPE CG-1, CG-2</p> <p>2025</p> <table border="1"> <thead> <tr> <th>DATE</th> <th>REVISION</th> <th>DESCRIPTION</th> </tr> </thead> <tbody> <tr> <td> </td> <td> </td> <td> </td> </tr> <tr> <td> </td> <td> </td> <td> </td> </tr> <tr> <td> </td> <td> </td> <td> </td> </tr> </tbody> </table>	DATE	REVISION	DESCRIPTION									
DATE	REVISION	DESCRIPTION											

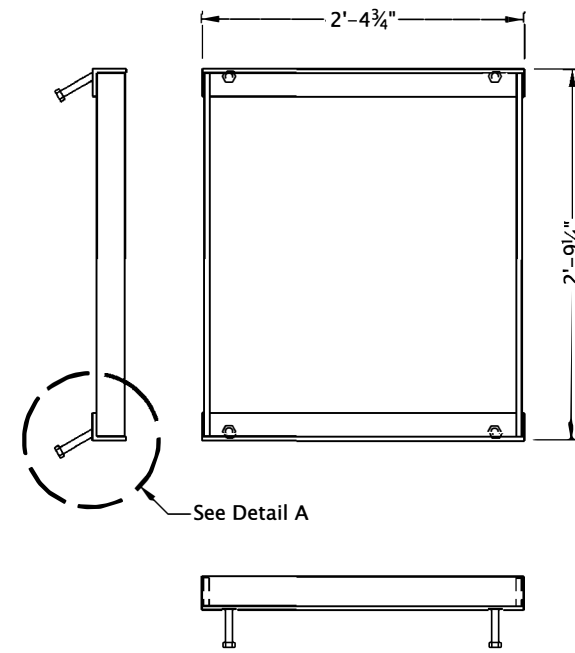
RD366



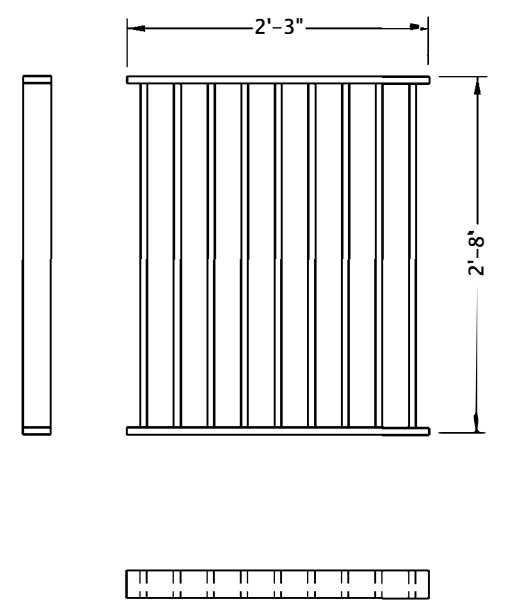
SECTION A - A



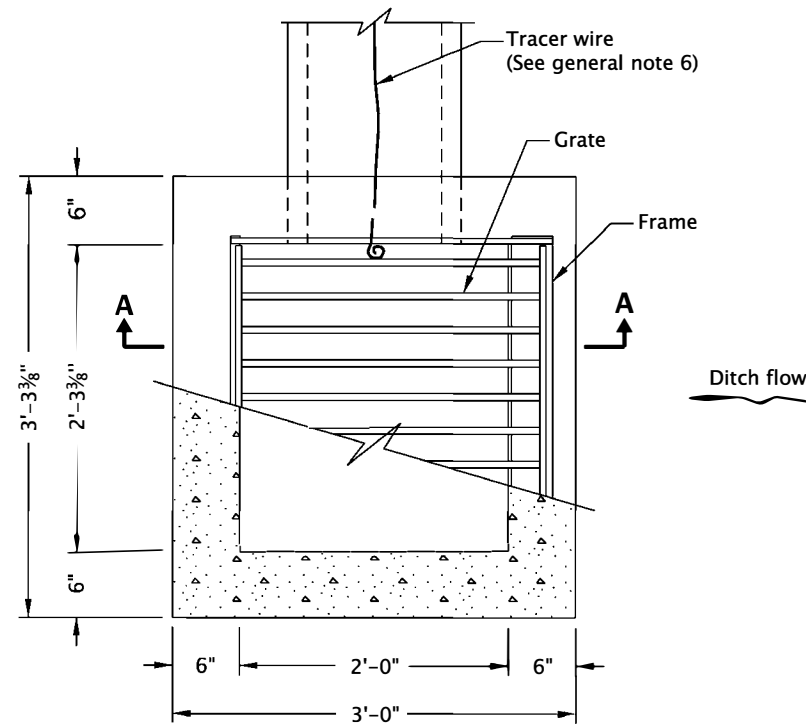
ELEVATION



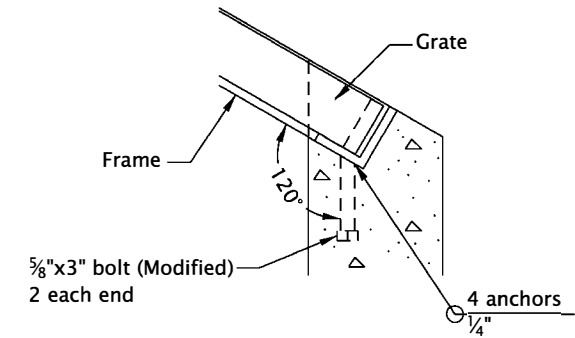
G-2 FRAME
(See general note 2)



G-2 GRATE (TYPE 1)
(See general note 2)



PLAN



DETAIL A
(Anchor bolt modification, see general note 2)

GENERAL NOTES FOR ALL DETAILS ON THIS SHEET:

1. All concrete shall be commercial grade concrete.
2. For frame & grate details not shown, see Std. Dwg. RD365.
G-2 (Type 2) grates may be used if approved by the engineer.
3. Catch basin, frame, and grates shall meet H2O loading.
4. Provide 18" sump unless otherwise approved by Engineer. For sump details, see Std. Dwg. RD364.
6. 5/8" cross bars shall be flush with the grate surface and may be fillet welded, resistance welded or electroforged to bearing bars.
6. See Std. Dwg. RD336 for tracer wire details, or approved alternate.
7. Max. pipe diameter varies with pipe material.
8. Do not use in locations where inlet can be struck by an errant vehicle, or provide shielding of inlet.
9. Inlet base may be cast-in-place or precast. Where precast inlet base is used as an alternate, a 4" compacted leveling bed of 3/4"-0 crushed aggregate shall be provided. All precast inlets shall conform to requirements of ASTM C913.
10. See Std. Dwg. RD339 for pipe to structure connections.
11. Location, elevation, diameter, slope, and number of pipe(s) varies, see project plans.

CALC. BOOK NO. N/A

SDR DATE 21-JUL-2015

NOTE: All material and workmanship shall be in accordance with the current City of The Dalles Standard Specifications

CITY OF THE DALLES STANDARD DRAWINGS

DITCH INLET
TYPE D

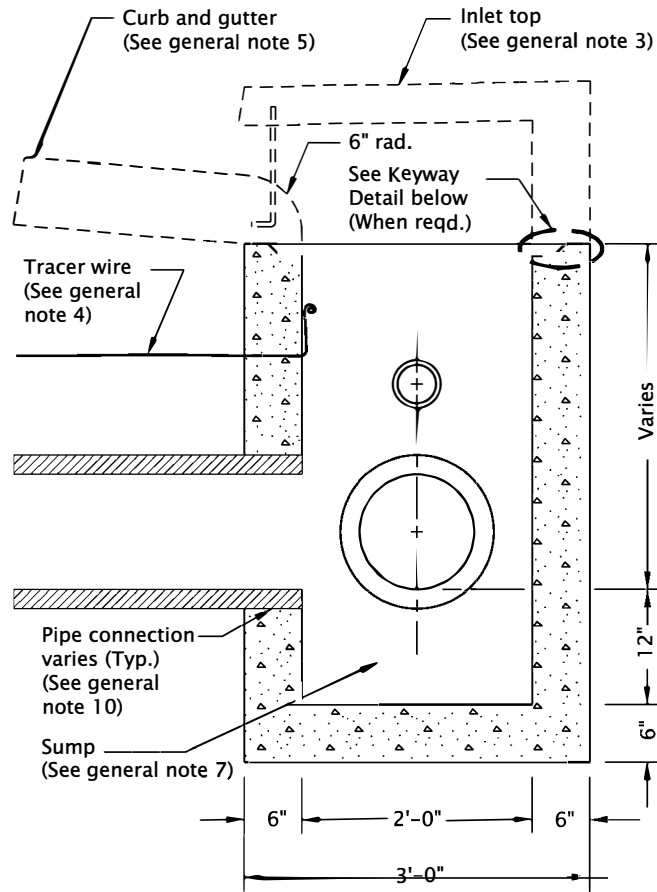
2025

DATE	REVISION DESCRIPTION

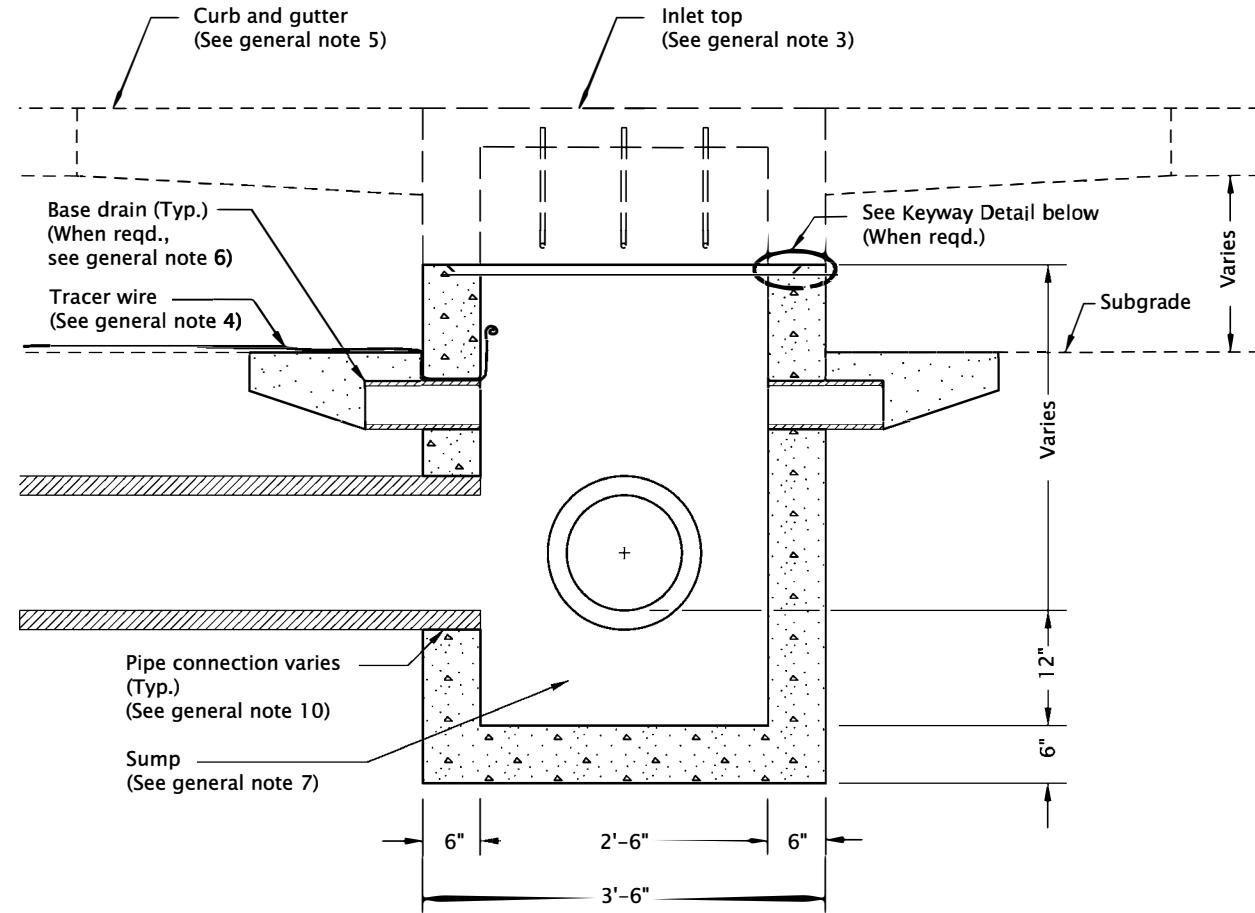
The selection and use of this Standard Drawing, while designed in accordance with generally accepted engineering principles and practices, is the sole responsibility of the user and should not be used without consulting a Registered Professional Engineer.

rd371.dgn 20-JUL-2020

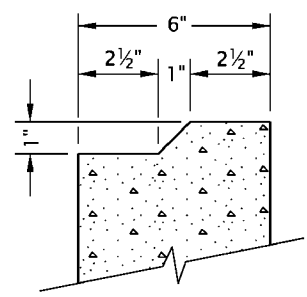
RD371



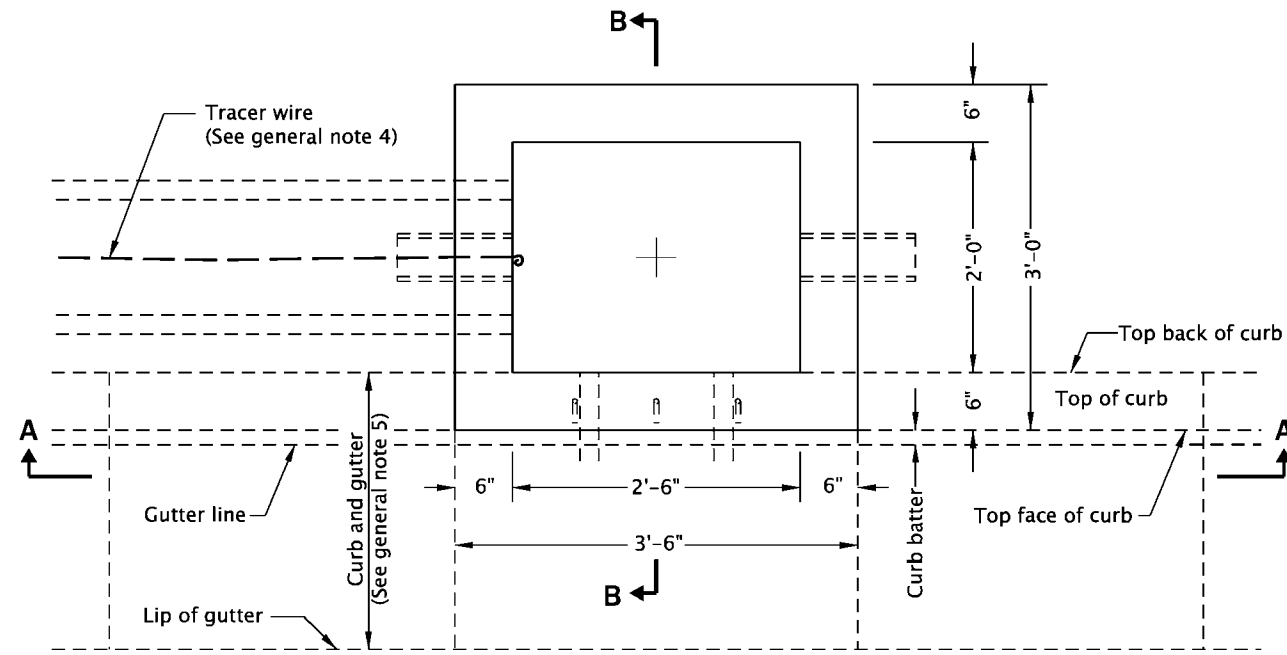
SECTION B - B



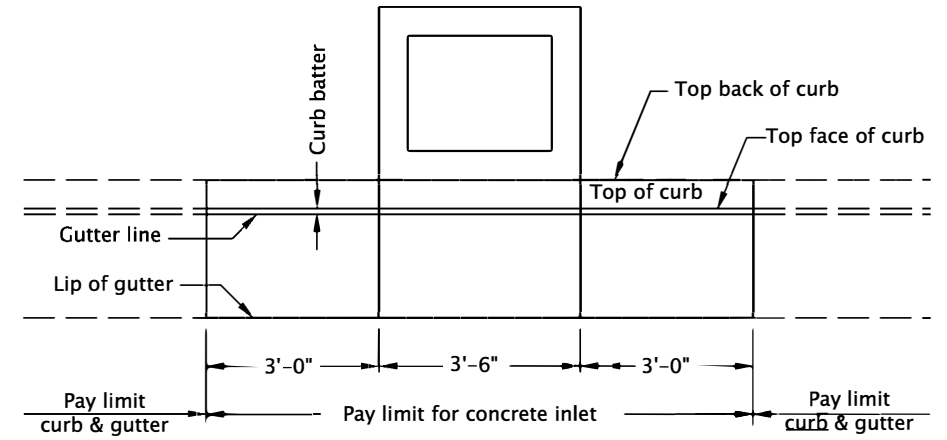
SECTION A - A



KEYWAY DETAIL



PLAN



PLAN
PAY LIMIT

GENERAL NOTES FOR ALL DETAILS ON THIS SHEET:

1. All concrete shall be commercial grade concrete.
2. Inlet base may be cast-in-place or precast. Where precast inlet base is used as an alternate, a 4" compacted leveling bed of 3/4"-0 crushed aggregate shall be provided. All precast inlets shall conform to requirements of ASTM C913.
3. See Std. Dwgs. RD372 & RD373 for inlet top details.
4. See Std. Dwg. RD336 for tracer wire details, or approved alternate.
5. See Std. Dwgs. RD700 & RD701 for curb and gutter details.
6. See Std. Dwg. RD364 for base drain details.
7. Provide 18" sump unless otherwise approved by City Engineer. For sump details, see Std. Dwg. RD364.
8. Location, elevation, diameter, slope, and number of pipe(s) varies, see project plans.
9. Max. pipe diameter varies with pipe material.
10. See Std. Dwg. RD339 for pipe to structure connections.

CALC. BOOK NO. N/A

SDR DATE 21-JUL-2015

NOTE: All material and workmanship shall be in accordance with the current City of The Dalles Standard Specifications

CITY OF THE DALLES STANDARD DRAWINGS

CONCRETE INLET BASE
TYPE CG-3

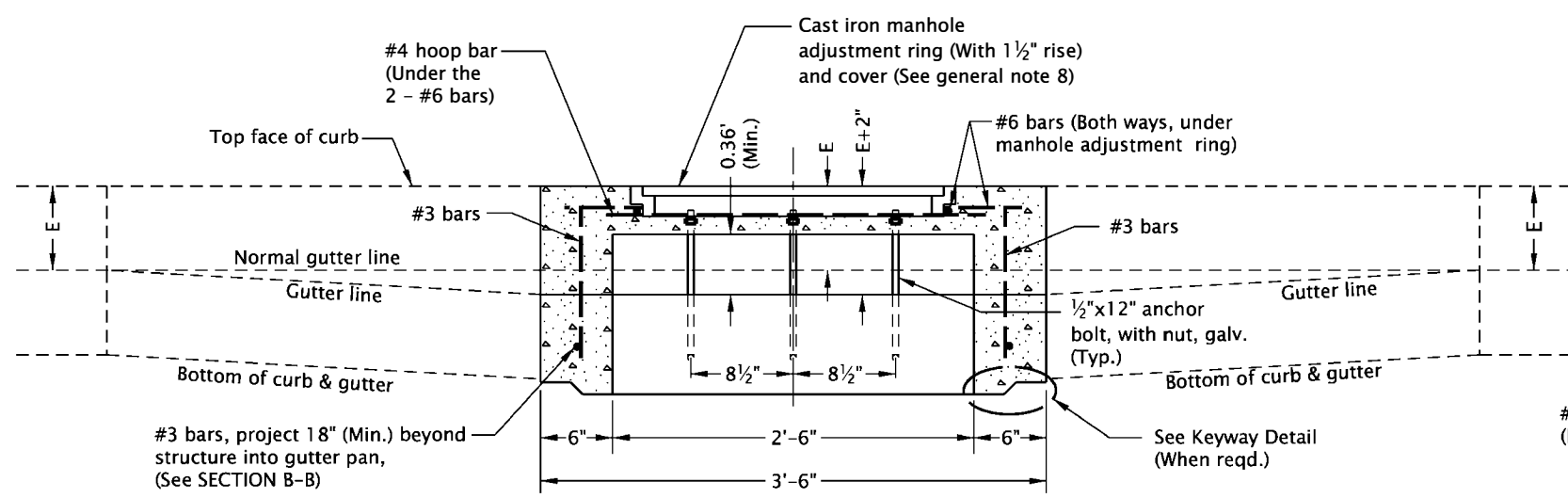
2025

DATE	REVISION	DESCRIPTION

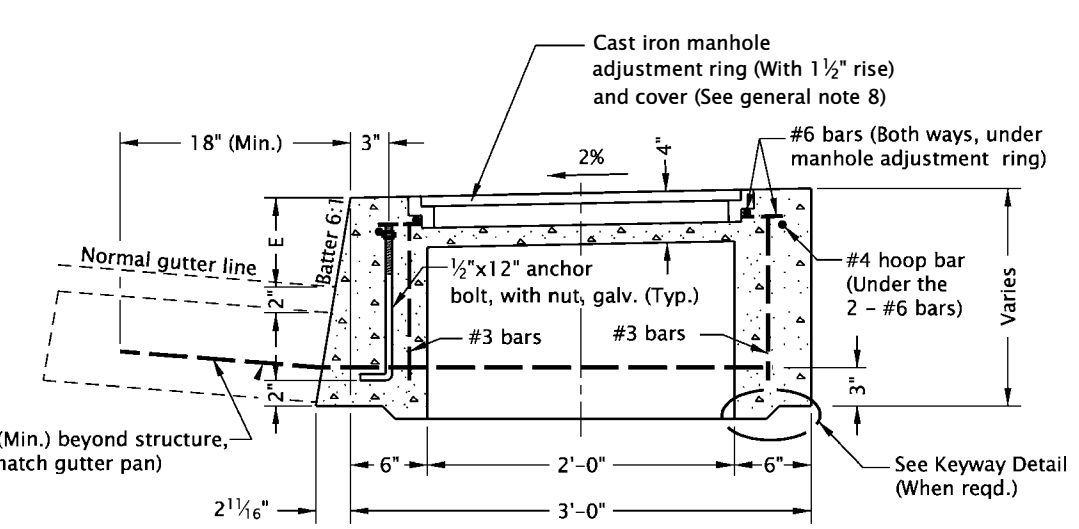
The selection and use of this Standard Drawing, while designed in accordance with generally accepted engineering principles and practices, is the sole responsibility of the user and should not be used without consulting a Registered Professional Engineer.

rd372.dgn 20-JUL-2020

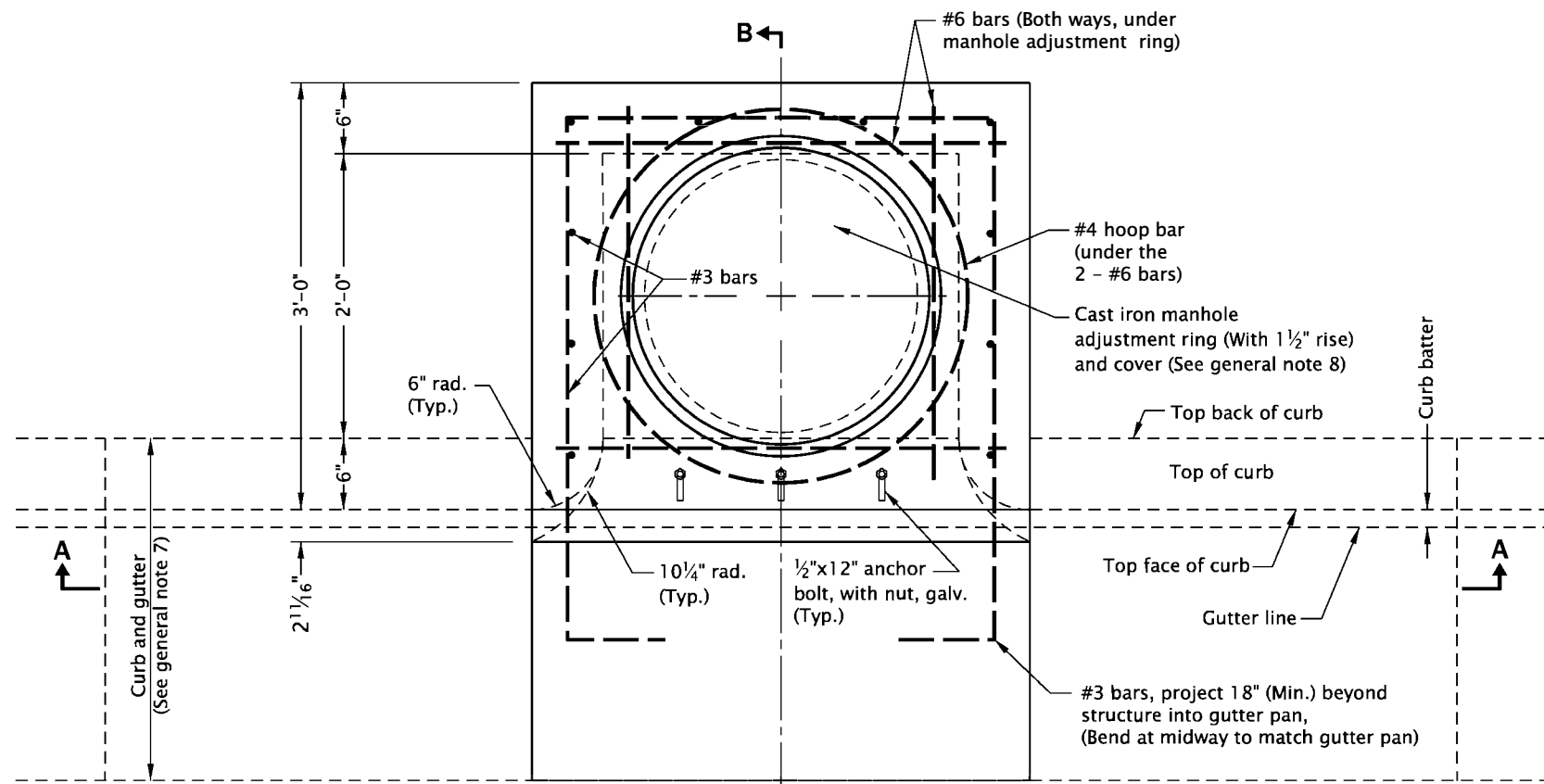
RD372



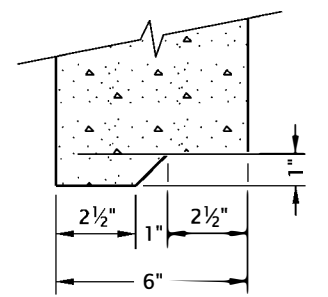
SECTION A - A



SECTION B - B



PLAN



KEYWAY DETAIL

- GENERAL NOTES FOR ALL DETAILS ON THIS SHEET:
1. All concrete shall be commercial grade concrete.
 2. Inlet top may be cast-in-place or precast. All precast inlets shall conform to requirements of ASTM C913.
 3. All reinforcement shall be 2" clear of nearest face of conc., unless otherwise shown.
 4. Vary anchor bolt length and reinforcing bar placement as required by curb exposure E (See note 7 below).
 5. See Std. Dwg. RD371 for inlet base details.
 6. See Std. Dwg. RD371 for inlet pay limit.
 7. See Std. Dwgs. RD700 & RD701 for curb and gutter details.
 8. See Std. Dwg. RD356 for cast iron manhole adjustment ring and cover.

CALC. BOOK NO. N/A SDR DATE 16-JAN-2019

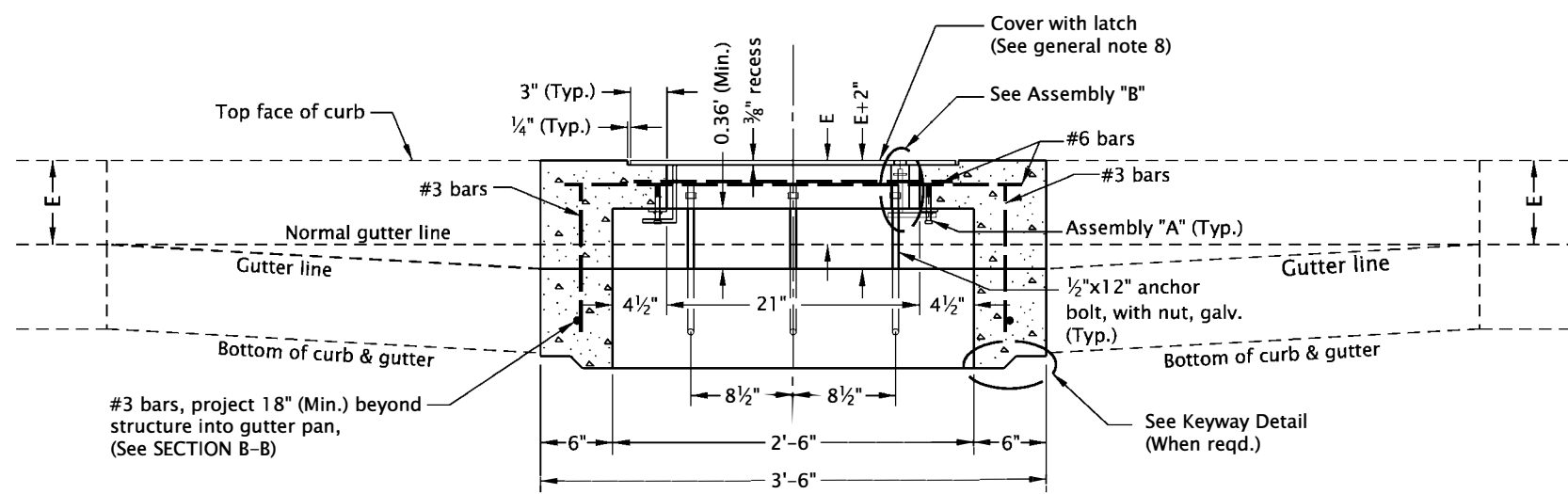
NOTE: All material and workmanship shall be in accordance with the current City of The Dalles Standard Specifications

The selection and use of this Standard Drawing, while designed in accordance with generally accepted engineering principles and practices, is the sole responsibility of the user and should not be used without consulting a Registered Professional Engineer.

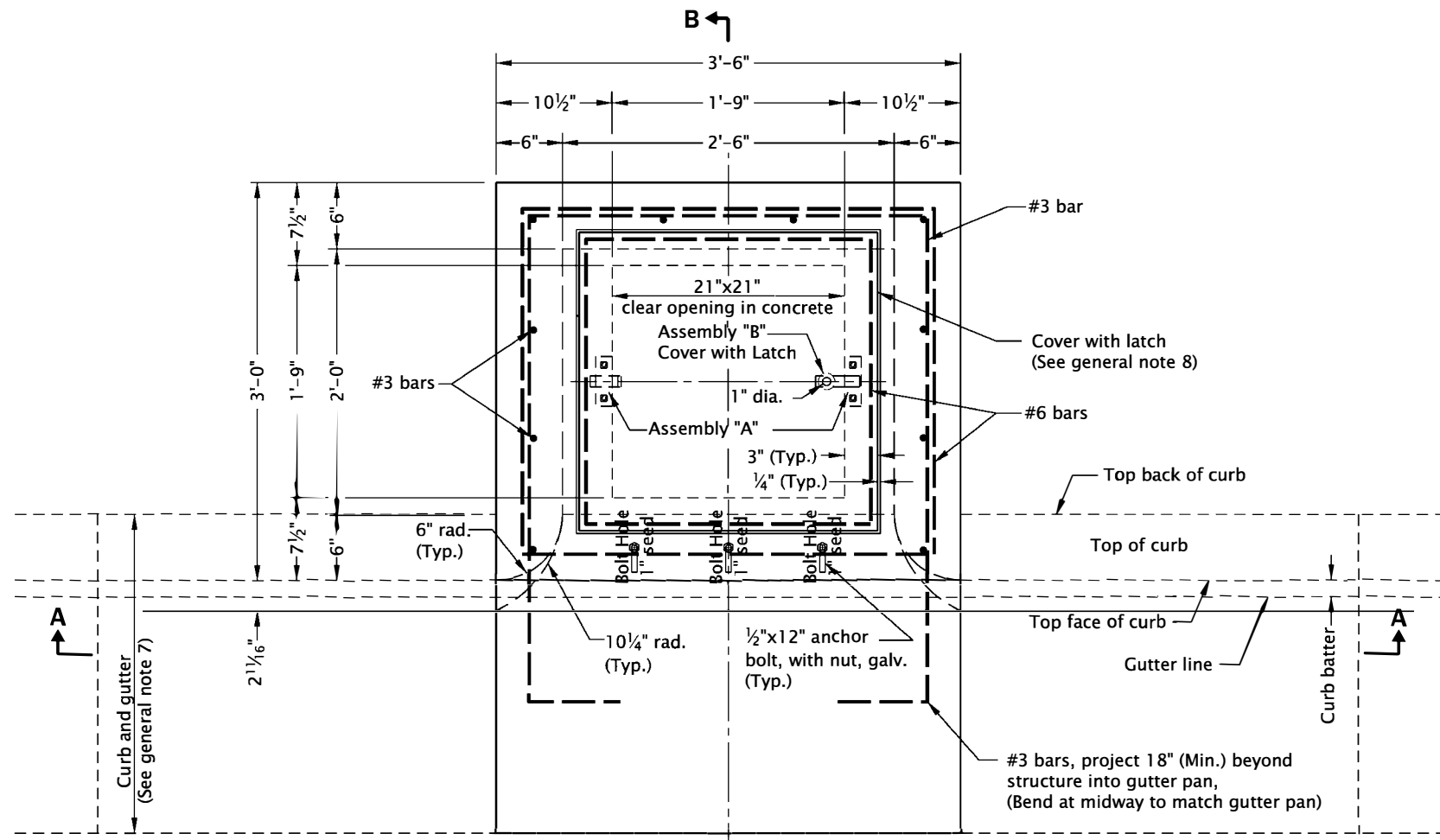
CITY OF THE DALLES STANDARD DRAWINGS

**CONCRETE INLET TOP, OPTION 1
TYPE CG-3**

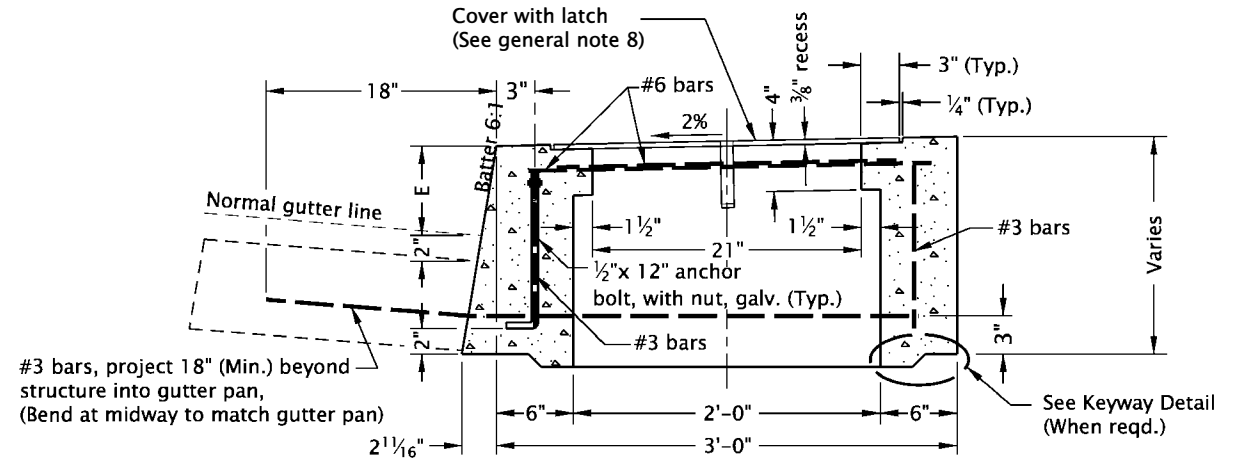
DATE	REVISION	DESCRIPTION



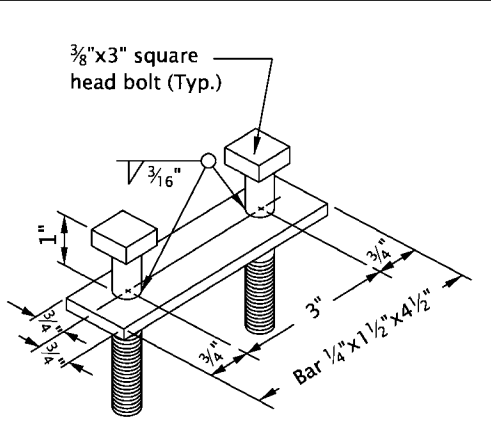
SECTION A - A



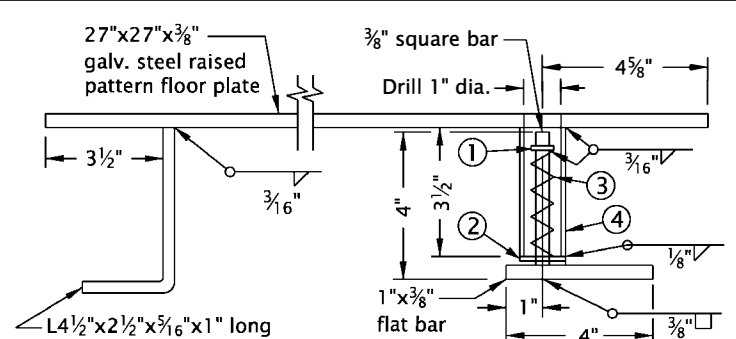
PLAN



SECTION B - B



ASSEMBLY "A"

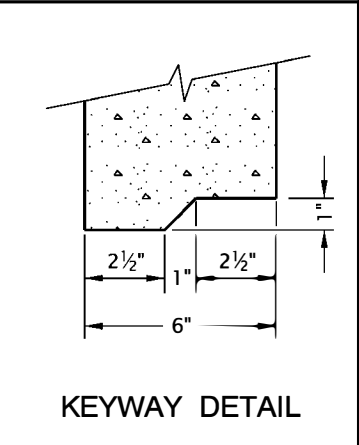


ASSEMBLY "B"
COVER WITH LATCH

- ① Washer used as spring stop. Weld washer to 3/8" square bar, 3/8" from end.
- ② 1 1/4" dia. washer used as a tube plug. Weld to tubing.
- ③ 90 lb comp. spring.
- ④ 1 1/4" x 0.125 tubing.

GENERAL NOTES FOR ALL DETAILS ON THIS SHEET:

1. All concrete shall be commercial grade concrete.
2. Inlet top may be cast-in-place or precast. All precast inlets shall conform to requirements of ASTM C913.
3. All reinforcement shall be 2" clear of nearest face of conc., unless otherwise shown.
4. Vary anchor bolt length and reinforcing bar placement as required by curb exposure E (see note 7 below).
5. See Std. Dwg. RD371 for inlet base details.
6. See Std. Dwg. RD371 for inlet pay limit.
7. See Std. Dwgs. RD700 & RD701 for curb and gutter details.
8. Provide cover with latch per Assembly A & Assembly B, hot dip galvanize after fabrication. Mount cover with latch flush with finish grade, in 3/8" deep concrete recess, with 1/4" horizontal clearance on all sides.

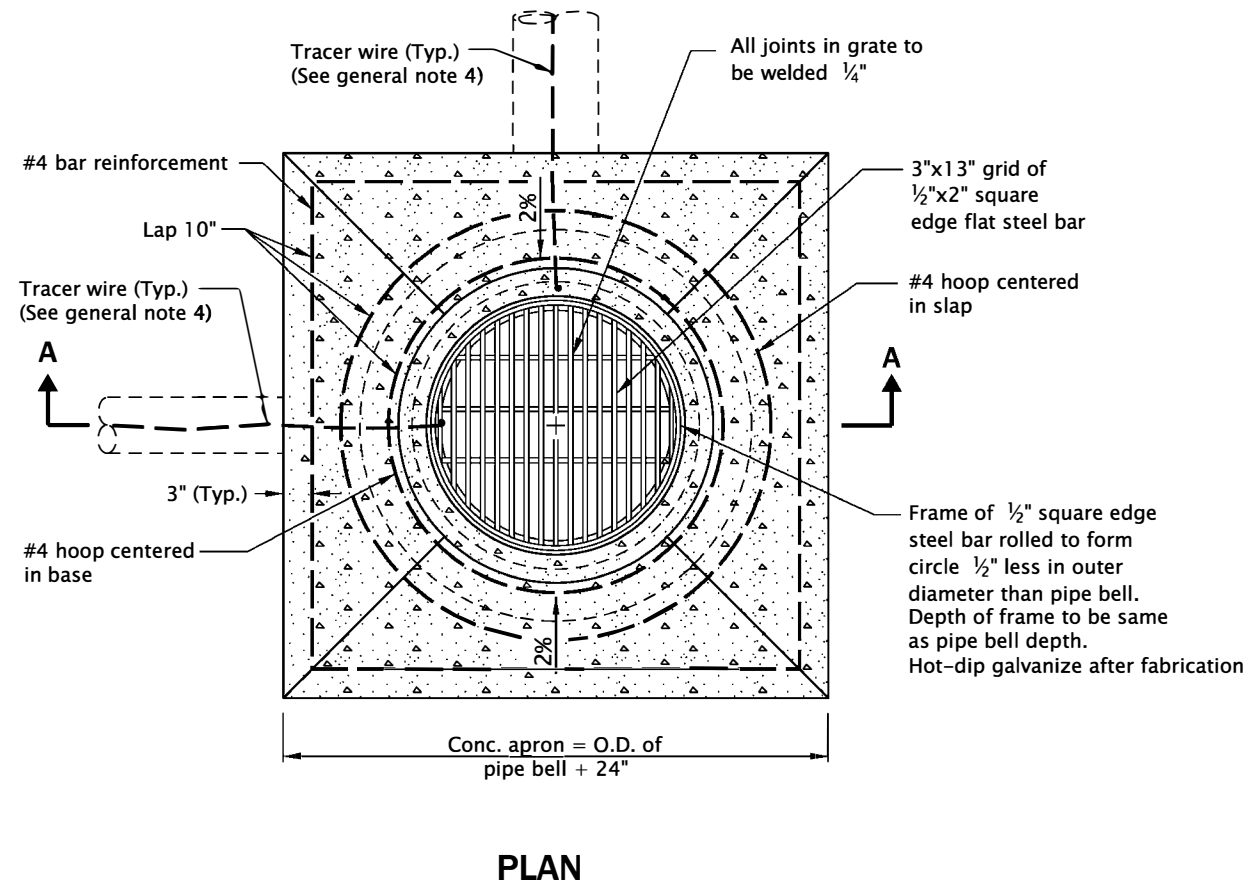
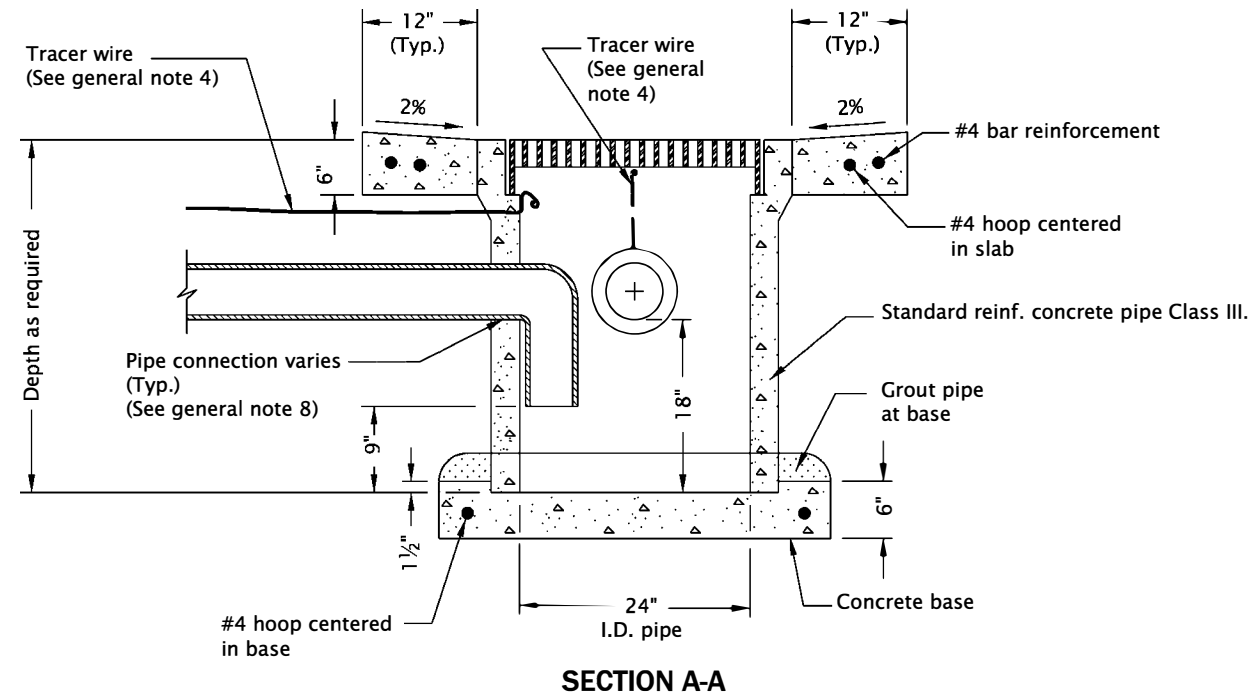


KEYWAY DETAIL

CALC. BOOK NO. N/A

The selection and use of this Standard Drawing, while designed in accordance with generally accepted engineering principles and practices, is the sole responsibility of the user and should not be used without consulting a Registered Professional Engineer.

SDR DATE <u>16-JAN-2019</u>	
NOTE: All material and workmanship shall be in accordance with the current City of The Dalles Standard Specifications	
CITY OF THE DALLES STANDARD DRAWINGS	
CONCRETE INLET TOP, OPTION 2	
TYPE CG-3	
2025	
DATE	REVISION DESCRIPTION



GENERAL NOTES FOR ALL DETAILS ON THIS SHEET:

1. Grates shall be bicycle-safe.
2. Precast concrete inlets may be used when specified or approved. All precast inlets shall conform to requirements of ASTM C913.
3. Anchor vertical leg of inlet pipe if not a glued joint.
4. See Std. Dwg. RD336 for tracer wire details.
5. All reinforcement shall be 2" clear of nearest face of conc., unless otherwise shown.
6. Max. connecting pipe diameter varies with pipe material.
7. All concrete shall be commercial grade concrete.
8. See Std. Dwg. RD339 for pipe to structure connections.
9. Location, elevation, diameter, slope, and number of pipe(s) varies, see project plans.

CALC. BOOK NO. N/A

SDR DATE 14-JUL-2014

NOTE: All material and workmanship shall be in accordance with the current City of The Dalles Standard Specifications

CITY OF THE DALLES STANDARD DRAWINGS

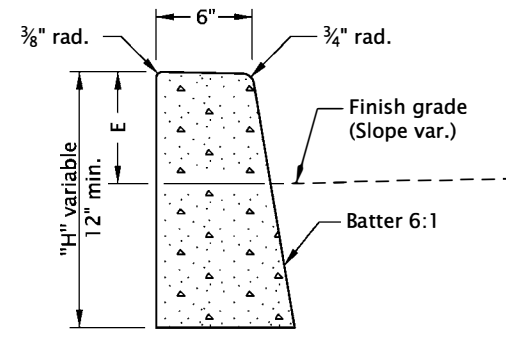
AREA DRAINAGE BASIN OR FIELD INLET

2025

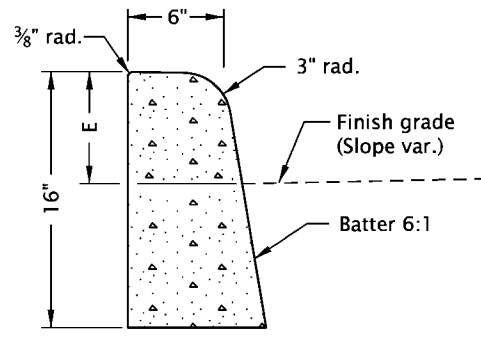
DATE	REVISION DESCRIPTION

The selection and use of this Standard Drawing, while designed in accordance with generally accepted engineering principles and practices, is the sole responsibility of the user and should not be used without consulting a Registered Professional Engineer.

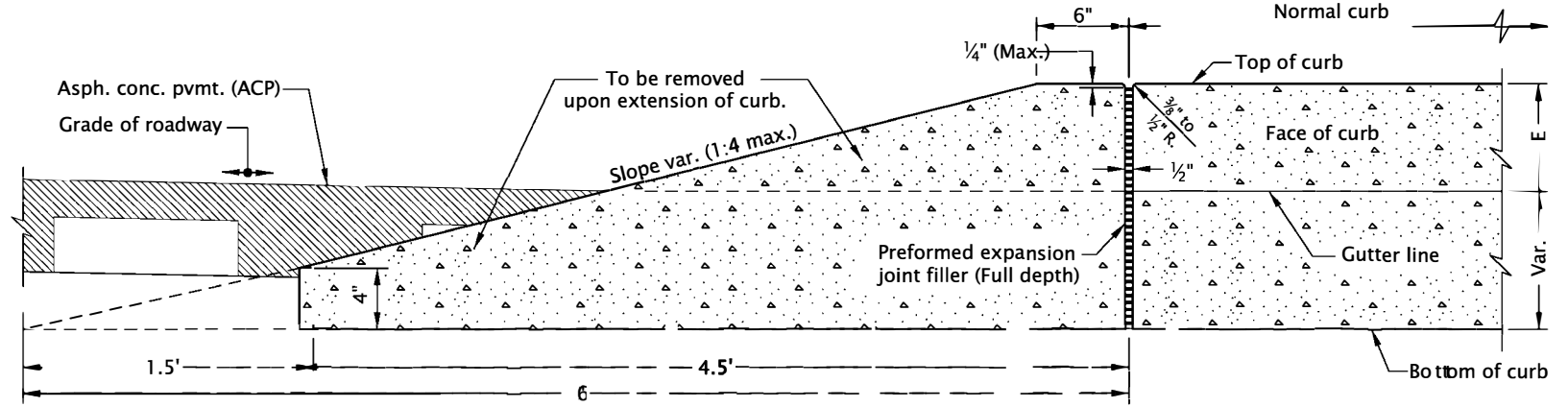
rd700.dgn 20-JUL-2020



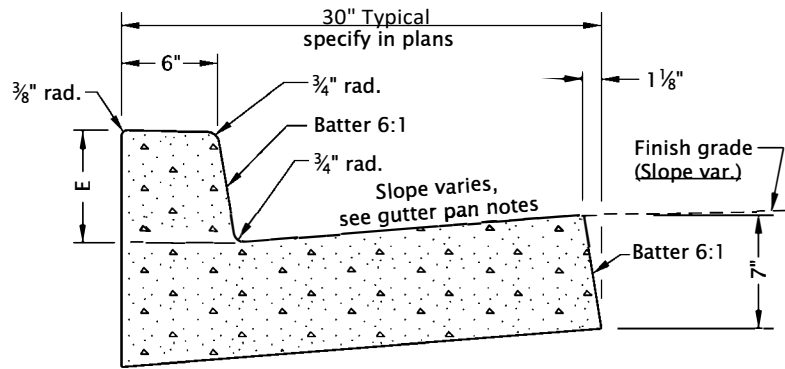
City of The Dalles Standard "H"=16" STANDARD CURB
(See general note 11)



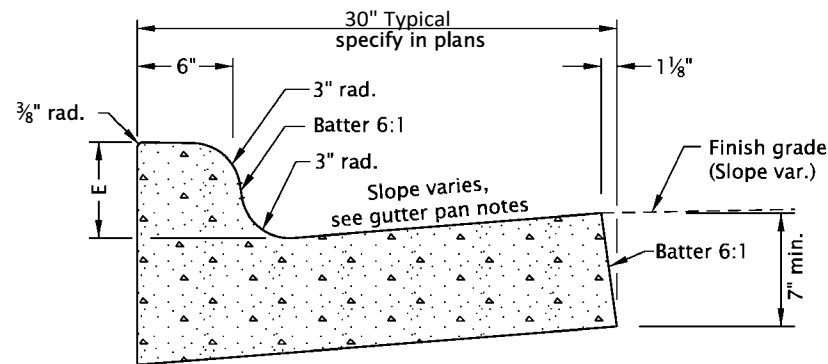
MOUNTABLE CURB
(See general note 11)



CURB ENDING DETAIL

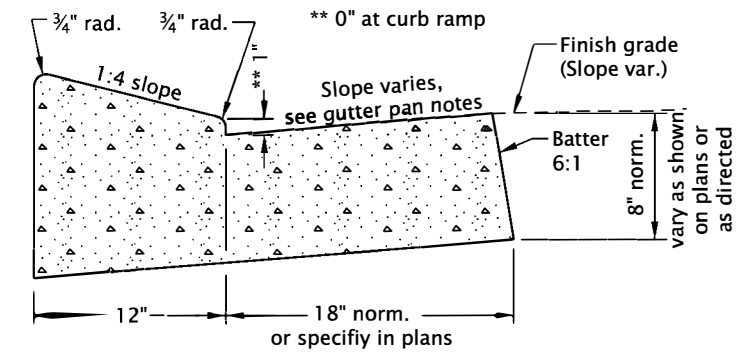


CURB AND GUTTER

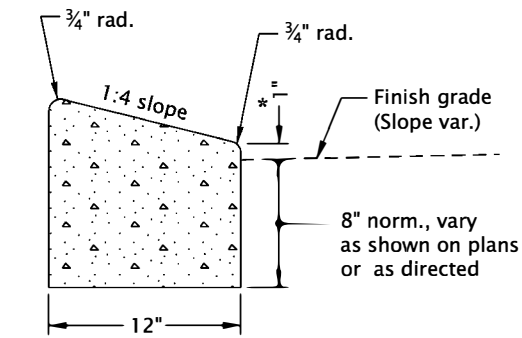


MOUNTABLE CURB AND GUTTER

GUTTER PAN NOTES:
Slope 5.0% normal.
Slope 4.0% max. at curb ramps.
Vary slope as reqd. for drainage.
Vary where shown on plans.

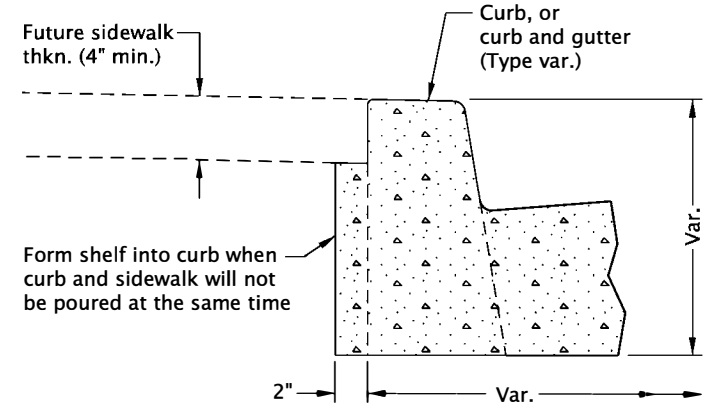


LOW PROFILE MOUNTABLE CURB AND GUTTER
(Where shown on plans)

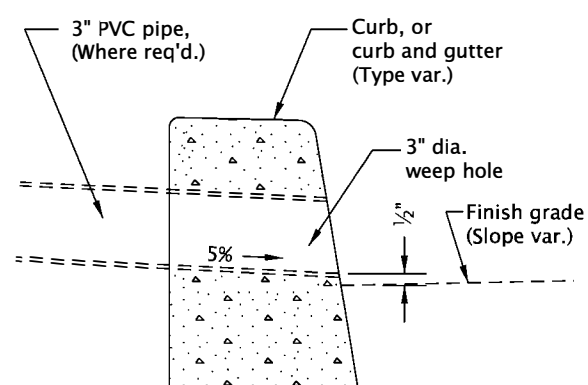


* 0" for Truck Apron

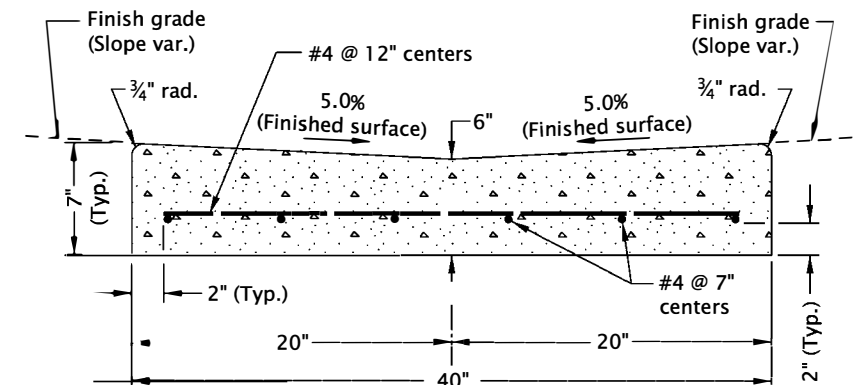
LOW PROFILE MOUNTABLE CURB
(See general note 11)



MODIFICATION FOR KEYWAY
(Where shown on plans)



WEEP HOLE DETAIL
(Where shown on plans)



VALLEY GUTTER

CALC. BOOK NO. N/A SDR DATE 20-JUL-2020

GENERAL NOTES FOR ALL DETAILS ON THIS SHEET:

1. Curb exposure "E" = 6" to 9", as measured vertically from flowline to highest point on curb. Vary as shown on plans or as directed. City of The Dalles standard "E" = 6".
2. Const. curb expansion joints at 200' maximum spacing, and at points of tangency, and at ends of each driveways.
3. Const. curb contraction joints at 15' maximum spacing, and at ends of each inlet and curb ramp.
4. Transitions shall be used to connect curbs of different exposures "E". ("E" is the total vertical dimension of those curb surfaces having a slope of 1:1 or steeper). Minimum desirable transition length shall be 20' for each 1" difference in "E".

5. Tops of all curbs shall slope toward the roadway at 1.5% max. (Max. 2.0% finished surface slope), unless otherwise shown, or as directed.
6. Dimensions are nominal, vary to conform with curb machine approved by the engineer.
7. Dimensions adjacent to radii are measured to the point of intersection of curb surfaces.
8. For sidewalk details, and monolithic curb & sidewalk, see Std. Dwgs. RD720 & RD721.
9. For drainage curbs, see Std. Dwg. RD701.
10. For curb ramp details, see Std. Dwgs. RD900 series
11. Curb and gutter is required at curb ramp.

The selection and use of this Standard Drawing, while designed in accordance with generally accepted engineering principles and practices, is the sole responsibility of the user and should not be used without consulting a Registered Professional Engineer.

NOTE: All material and workmanship shall be in accordance with the current City of The Dalles Standard Specifications

CITY OF THE DALLES STANDARD DRAWINGS

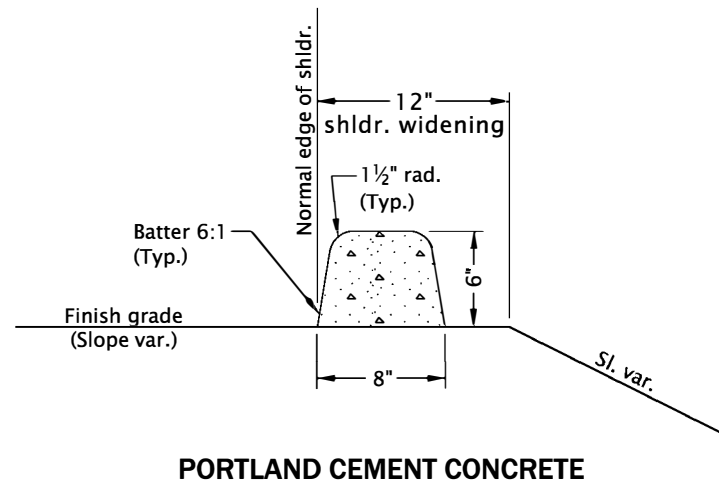
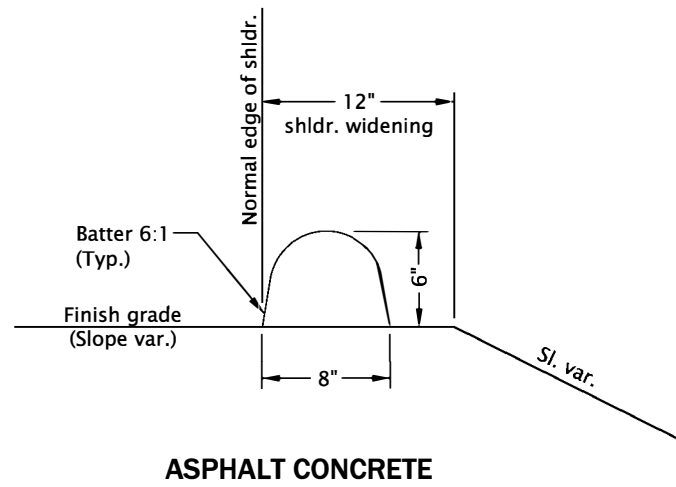
CURBS

2025

DATE	REVISION	DESCRIPTION

RD700

rd701.dgn 20-JUL-2020

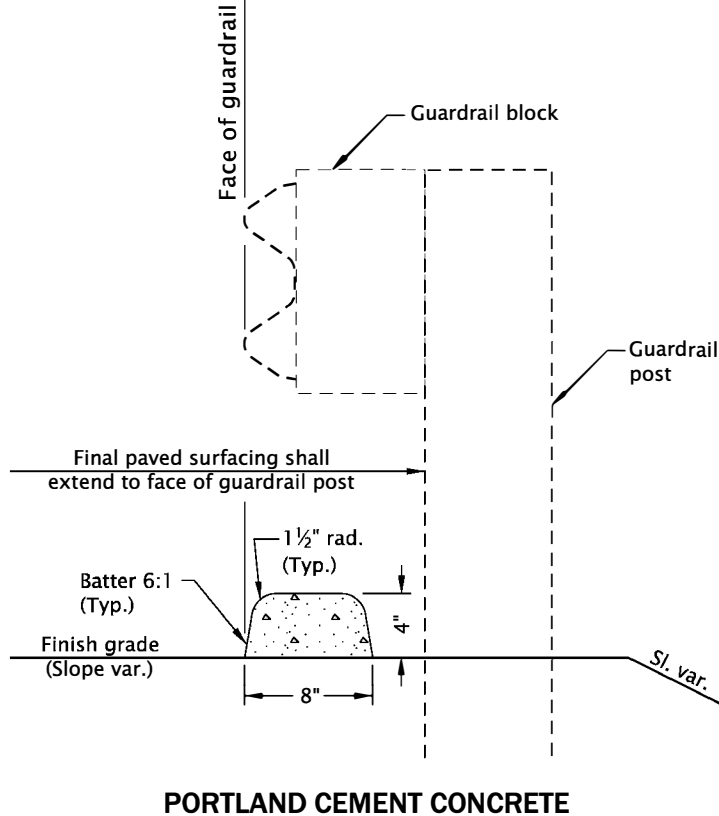
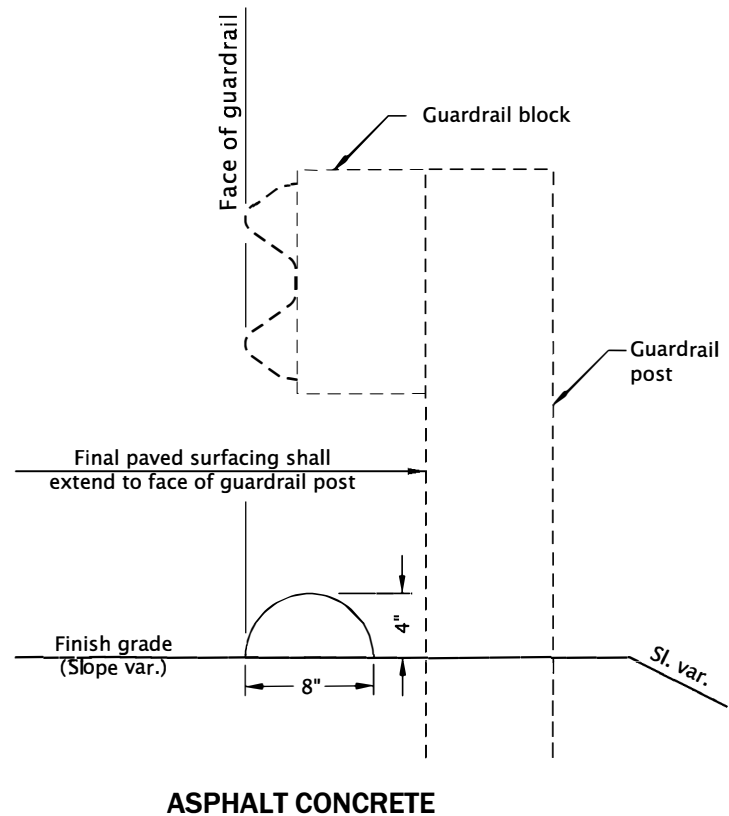


DRAINAGE CURBS
(See general note 4)

GENERAL NOTES FOR ALL DETAILS ON THIS SHEET:

1. For PCC drainage curbs, construct curb expansion joints at 200' maximum spacing, and at points of tangency.
2. For PCC drainage curbs, construct curb contraction joints at 15' maximum spacing.
3. Dimensions are nominal, vary to conform with curb machine approved by the engineer.
4. When bonding to dense graded ACP, apply epoxy cement between surfaces.
5. When drainage curb is required, curb alignment shall be the same as face of guardrail, as shown above. When a run of drainage curb, or any part thereof, is placed under guardrail, curb height shall be 4".
6. For other curb types, see Std. Dwg. RD700.
7. For guardrail details not shown, see Std. Dwg. RD400.

RD701



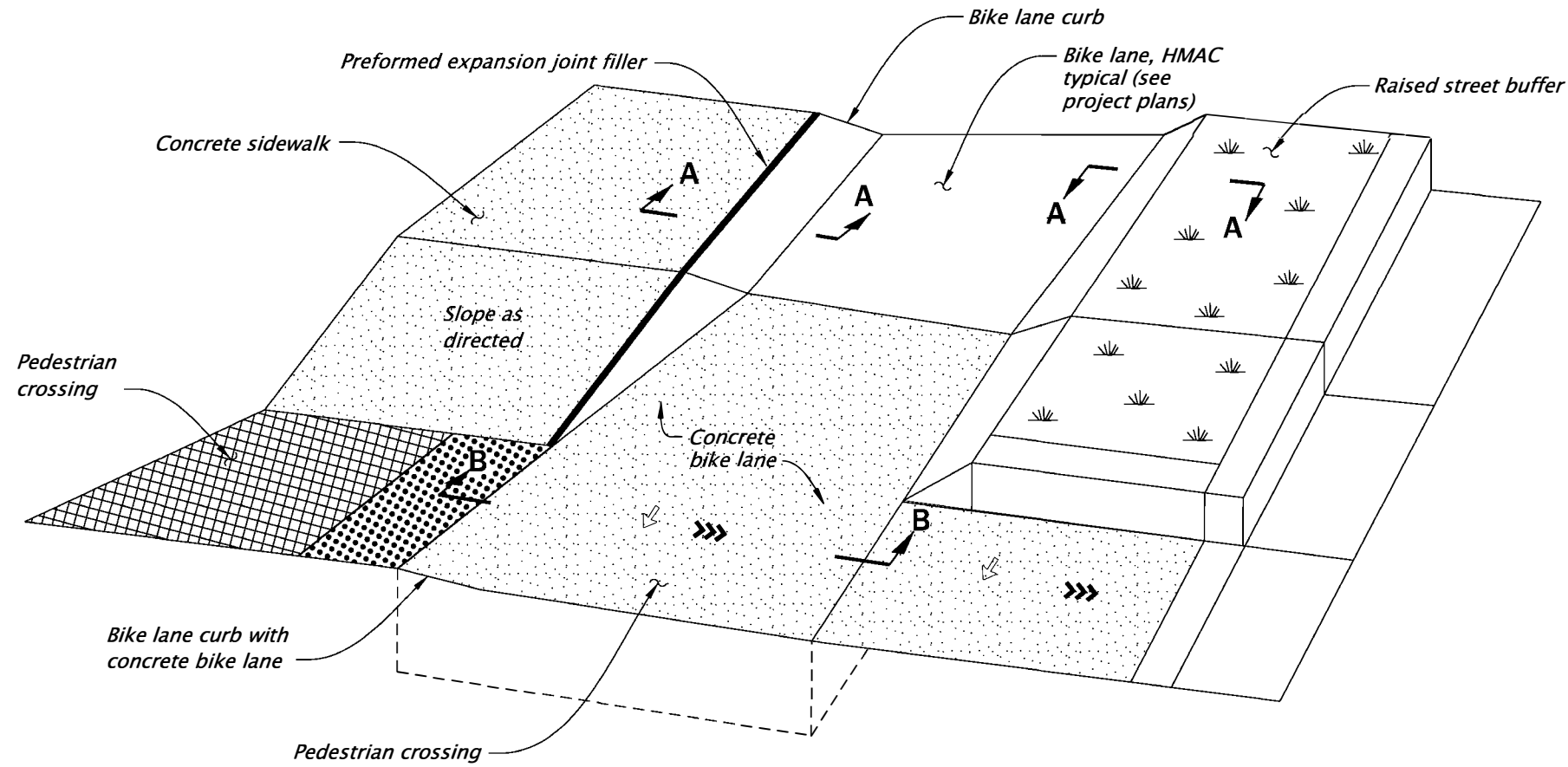
DRAINAGE CURBS UNDER GUARDRAIL
(See general note 4)

CALC. BOOK NO. N/A SDR DATE 20-JUL-2020

NOTE: All material and workmanship shall be in accordance with the current City of The Dalles Standard Specifications

<p><i>The selection and use of this Standard Drawing, while designed in accordance with generally accepted engineering principles and practices, is the sole responsibility of the user and should not be used without consulting a Registered Professional Engineer.</i></p>		CITY OF THE DALLES STANDARD DRAWINGS	
		DRAINAGE CURBS	
		2025	
DATE		REVISION	DESCRIPTION

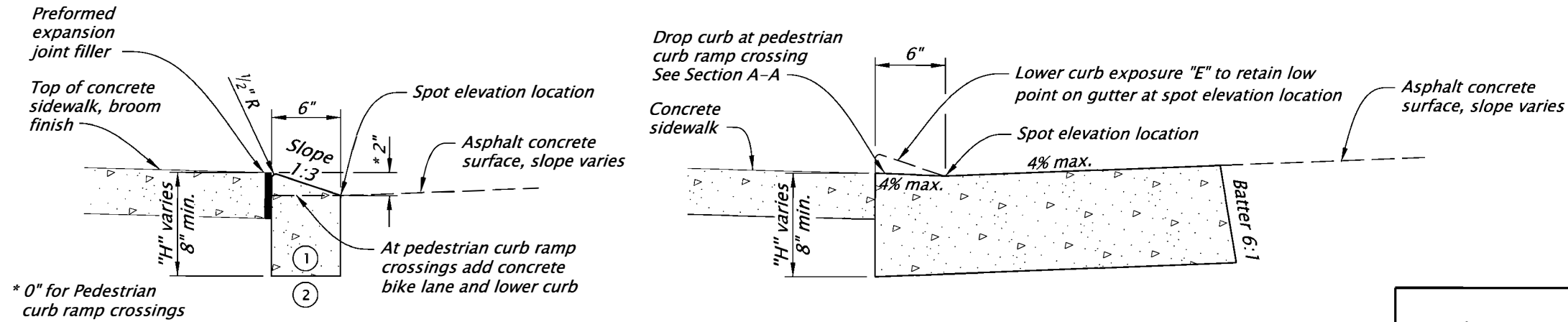
14-JAN-2022
RD702.dgn



GENERAL NOTES FOR ALL DETAILS ON THIS SHEET:

1. Bike Lane Curb details are based on applicable ODOT Standards.
2. Lower bike lane curb at all curb ramp pedestrian crossings.
3. Bike lane curb may continue across driveways or be lowered per curb ramps. See project plans.
4. On separated bike lanes (where bike lane is apart from road shoulder), gutter pan shall not end in bike lane.
5. On or along state highways, where curb and gutter is required at curb ramps, add concrete bike lane to bike lane curb at curb ramps and at inlets.
6. Omit preformed expansion joint filler at curb ramps and where landscaping is adjacent to curb.
7. Transition between curb styles to connect curbs of different exposures "E". Transition length shall be 3' for each 1" difference in "E" unless specified in project plans.
8. Check the gutter flow depth to assure that the design flood does not spread across more than 2-feet of the bike lane and does not overtop the back of sidewalk at curb ramps. Place inlet in curb at low points and at upstream side of curb ramps or perform other approved design mitigation. Transition to standard curb on each side of inlet by lowering bike lane. See dwg. no. RD367.
9. Dimensions adjacent to radii are measured to the point of intersection of curb surfaces.
10. See dwg. nos. RD720 and RD727 for monolithic curb and sidewalk details. See dwg. nos. RD900 series for curb ramp details. See dwg. no. RD1140 for layout of separated bike lane crossings details.

**BIKE LANE CURB WITH CONCRETE BIKE LANE
ISOMETRIC VIEW**



LEGEND:

- Sidewalk or other traversable surface
- Detectable warning surface (DWS)
- Level area (turning space/landing)
- Running slope, 4.0% maximum. (Maximum 4.9% finished surface slope)
- Cross slope 1.5% maximum (Maximum 2.0% finished surface slope)

**SECTION A-A
BIKE LANE CURB
(Where shown on plans)**

- ① Control joints cut at 15' intervals, minimum 2" depth
- ② Place a minimum of 6" approved granular base at 95% MPD (3/4" Minus crushed granular)

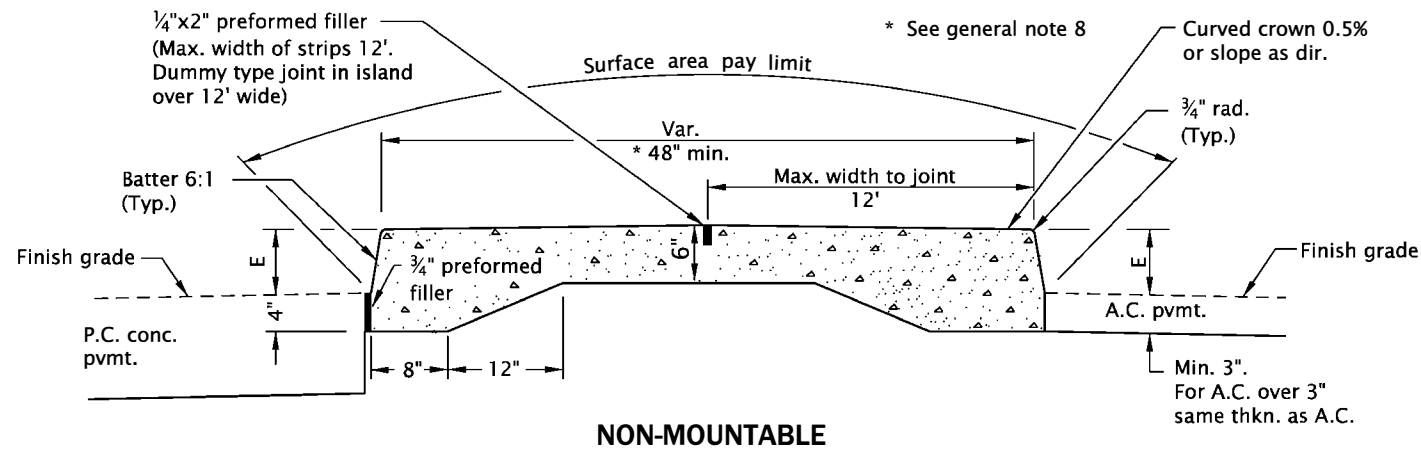
**SECTION B-B
BIKE LANE CURB WITH CONCRETE BIKE LANE
(Where shown on plans)**

The selection and use of this Standard Drawing, while designed in accordance with generally accepted engineering principles and practices, is the sole responsibility of the user and should not be used without first consulting a Registered Professional Engineer.

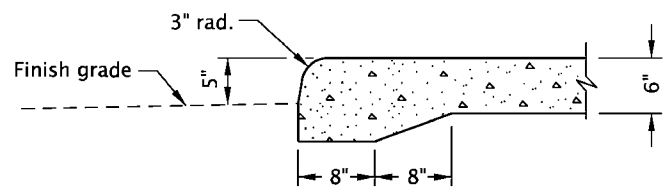
All materials shall be in accordance with the current City of The Dalles Standard Specifications.			
CITY OF THE DALLES STANDARD DRAWINGS			
BIKE LANE CURBS			
2025			
DATE	REVISION DESCRIPTION		
12-2021	NEW DRAWING CREATED		
CALC. BOOK NO.	N/A	SDR DATE	20-JUL-2020
			RD702

Effective Date: January 1, 2025– December 31, 2025

rd705.dgn 20-JUL-2020



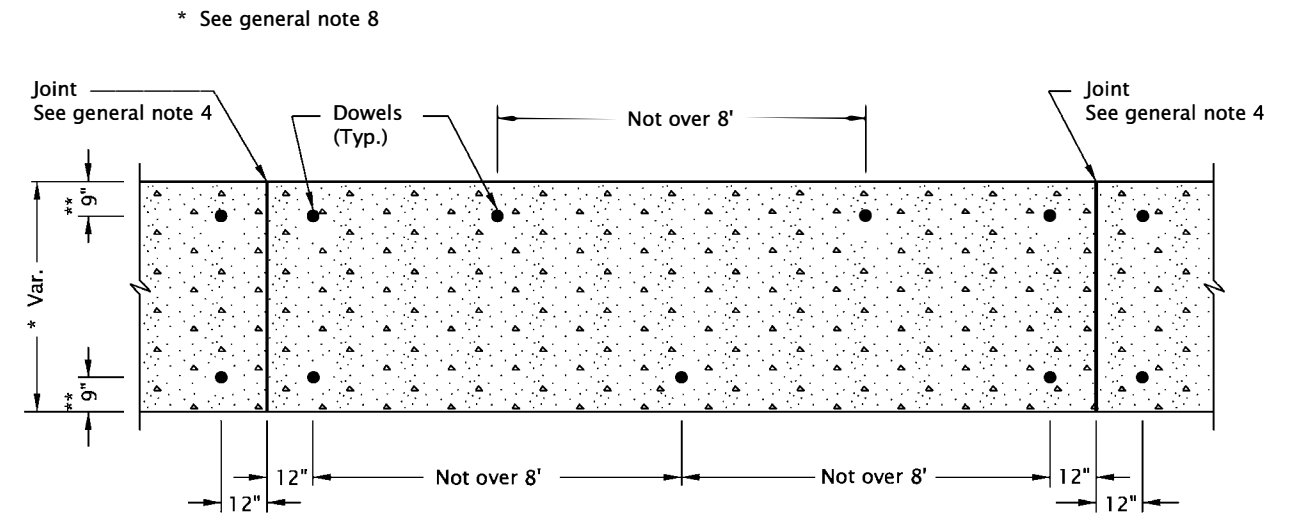
NON-MOUNTABLE



MOUNTABLE

(For surfacing details not shown, see above)

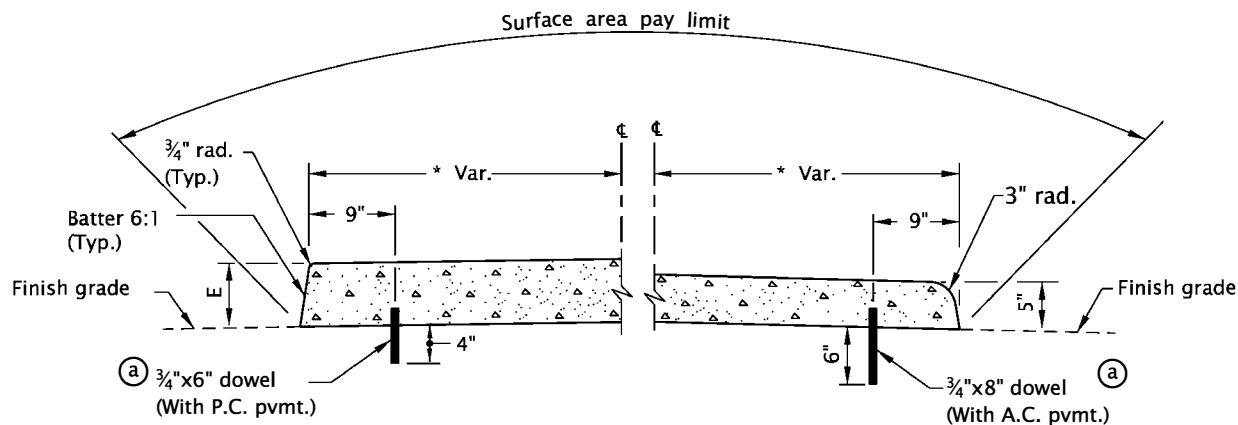
TYPE A



**DOWEL PLAN
FOR TYPE C OR TYPE CA ISLANDS & TRANSITIONS
(ON SURFACE OF NEW OR EXISTING PAVEMENT)**

** Also see below for type CA island requirement.

* See general note 8

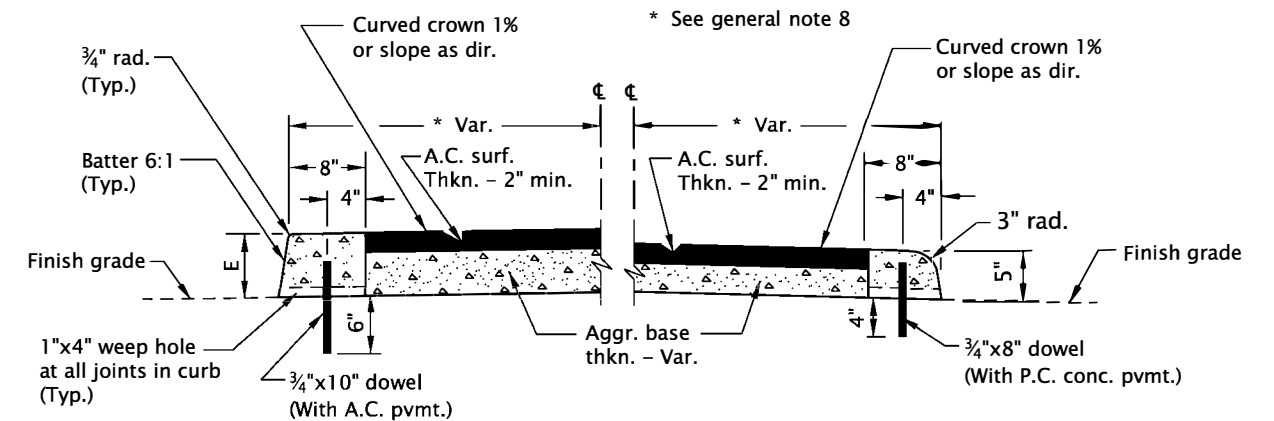


NON-MOUNTABLE

MOUNTABLE

TYPE C

(a) No dowels reqd. for Type C islands 5' wide or wider



NON-MOUNTABLE

MOUNTABLE

TYPE CA

GENERAL NOTES FOR ALL DETAILS ON THIS SHEET:

1. Curb exposure "E" = 6" normal. Vary as shown on plans or as directed. Standard batter is shown. Vary as shown on typical section or as directed.
3. Transverse joints in conc. islands to match joints in conc. pvmt. and to be of same type (Omit dowels in expansion joints).
4. Set joint spacing 200' max. for expansion and 15' max. for contraction.
5. Place preformed filler along one side of conc. islands in conc. pvmt. and around all curved ends.

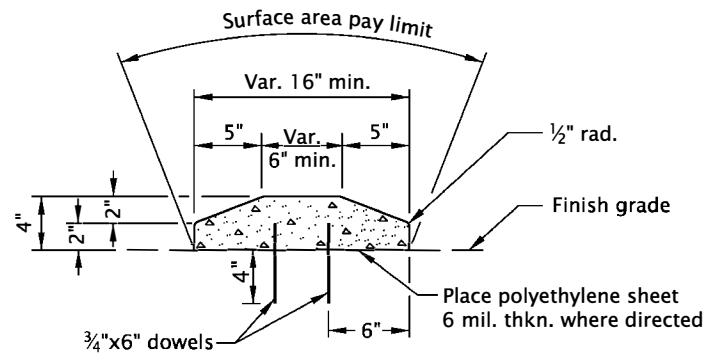
6. Dowels shall be 3/4" dia. with length as shown. In new conc. pvmt. set dowels before conc. hardens. In extg. conc. pvmt. drill holes 1 1/2" dia. and grout dowels in. In A.C. pvmt. drive dowels.
7. For transitions to traffic separators, see Std. Dwg. RD706.
8. Minimum island width is 48". For accessible route islands, see Std. Dwg. RD710.

CALC. BOOK NO. <u>N/A</u>	SDR DATE <u>16-JUL-2018</u>
NOTE: All material and workmanship shall be in accordance with the current City of The Dalles Standard Specifications	
CITY OF THE DALLES STANDARD DRAWINGS	
ISLANDS	
2025	
DATE	REVISION DESCRIPTION

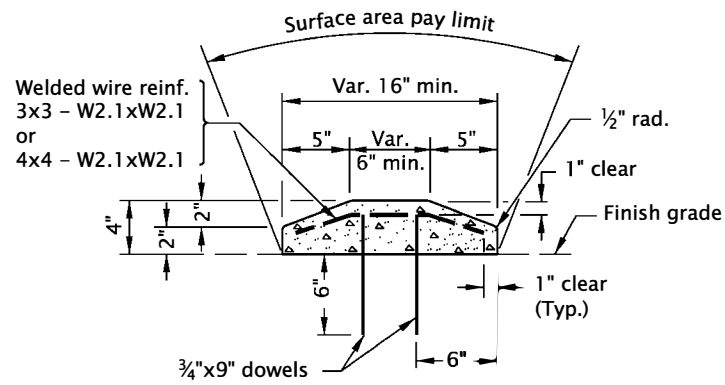
RD705

rd706.dgn 20-JUL-2020

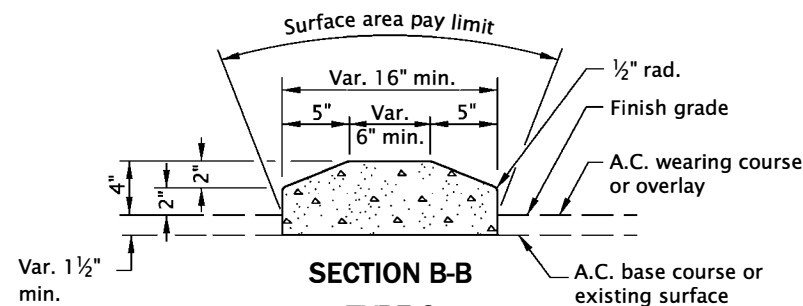
RD706



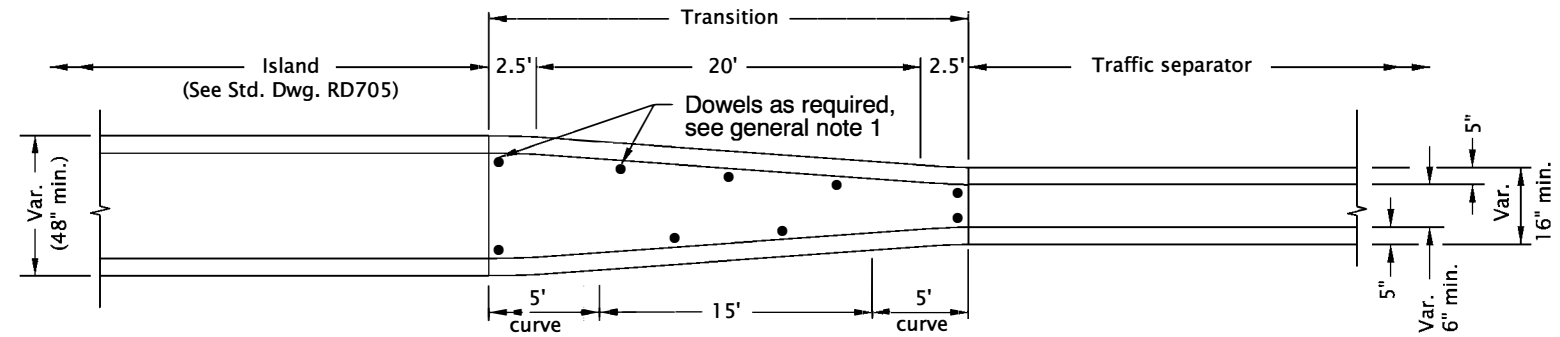
**SECTION B-B
TYPE A
TRAFFIC SEPARATOR ON P.C. CONC. PVMT.**



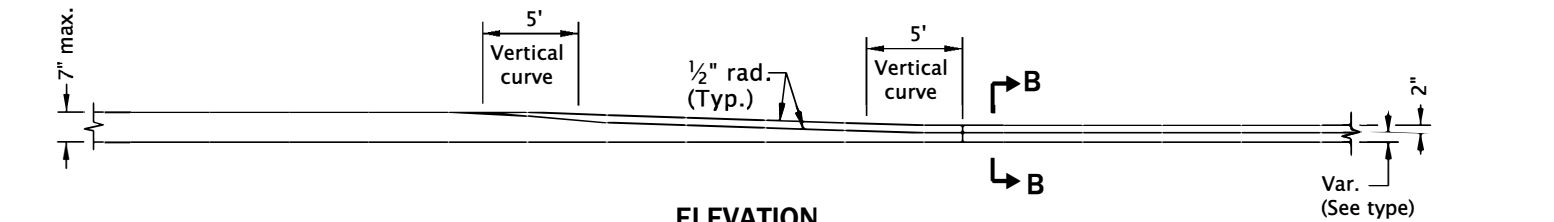
**SECTION B-B
TYPE B
TRAFFIC SEPARATOR ON EXTG. A.C. PVMT.**



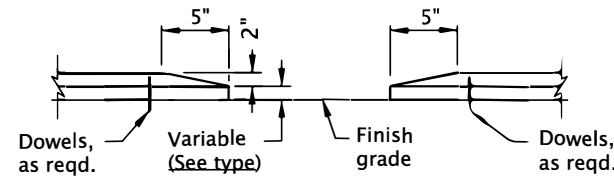
**SECTION B-B
TYPE C
TRAFFIC SEPARATOR ON NEW A.C. PVMT.
OR ON EXISTING A.C. PVMT. WITH OVERLAY**



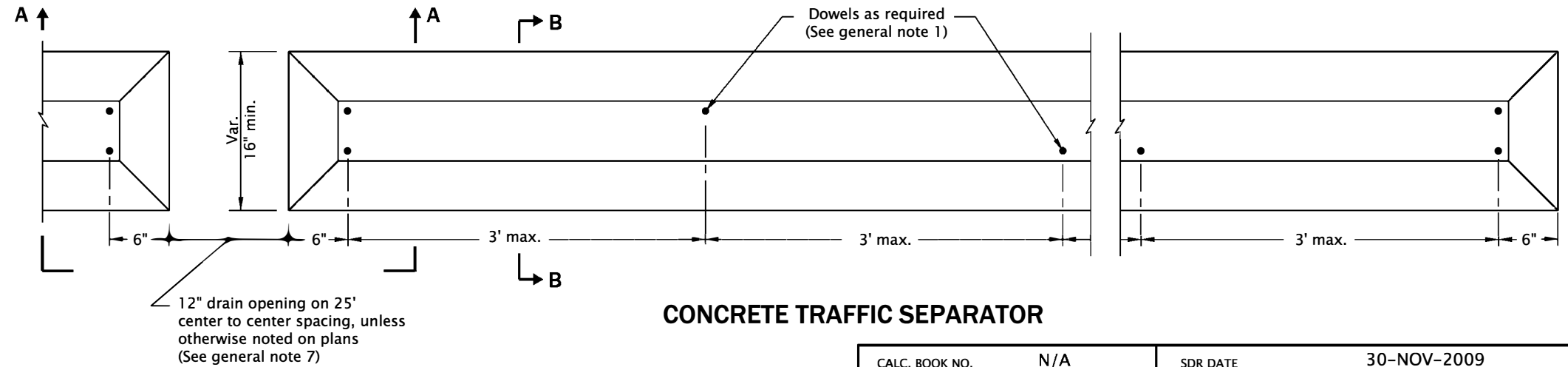
PLAN



**ELEVATION
TRANSITION FROM ISLAND TO TRAFFIC SEPARATOR**



SECTION A-A



CONCRETE TRAFFIC SEPARATOR

GENERAL NOTES FOR ALL DETAILS ON THIS SHEET:

- In transitions conform to dowel plan per Std. Dwg. RD705.
- Standard slope face is shown. Vary as shown on typical section or as directed.
- Transverse joints in conc. traffic separators and transitions to match joints in conc. pvm. and to be of same type (Omit dowels in expansion joints).
- Set joint spacing 200' max. for expansion and 15' max. for contraction.
- Place preformed filler along one side of conc. transitions in conc. pvm. and around all curved ends.

- Dowels shall be 3/4" dia. with length as shown. In new conc. pvm. set dowels before conc. hardens. In extg. conc. pvm. drill holes 1 1/2" dia. and grout dowels in. In A.C. pvm. drive dowels.
- Site conditions normally require a project specific drain opening spacing design, which considers roadway conditions (sheet flow limits, cross slope, superelevation, profile, pavement type, lane and shoulder widths, etc.).

CALC. BOOK NO. N/A SDR DATE 30-NOV-2009

NOTE: All material and workmanship shall be in accordance with the current City of The Dalles Standard Specifications

CITY OF THE DALLES STANDARD DRAWINGS

**TRAFFIC SEPARATORS
AND TRANSITIONS**

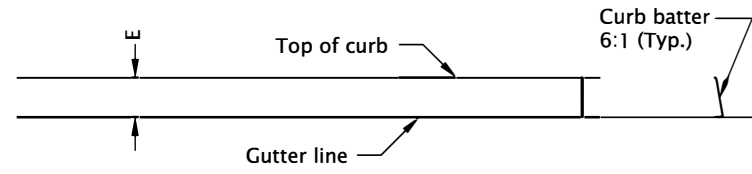
2025

DATE	REVISION	DESCRIPTION

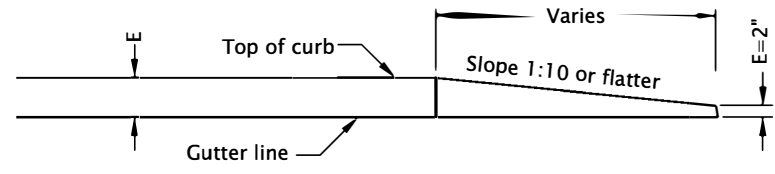
The selection and use of this Standard Drawing, while designed in accordance with generally accepted engineering principles and practices, is the sole responsibility of the user and should not be used without consulting a Registered Professional Engineer.

rd707.dgn 20-JUL-2020

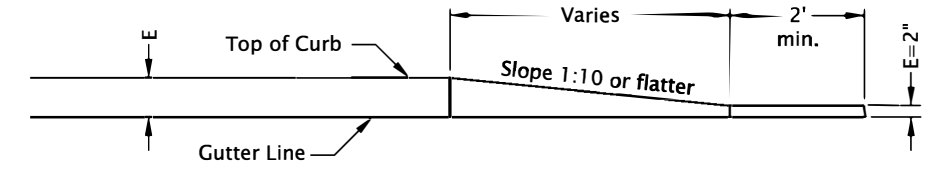
RD707



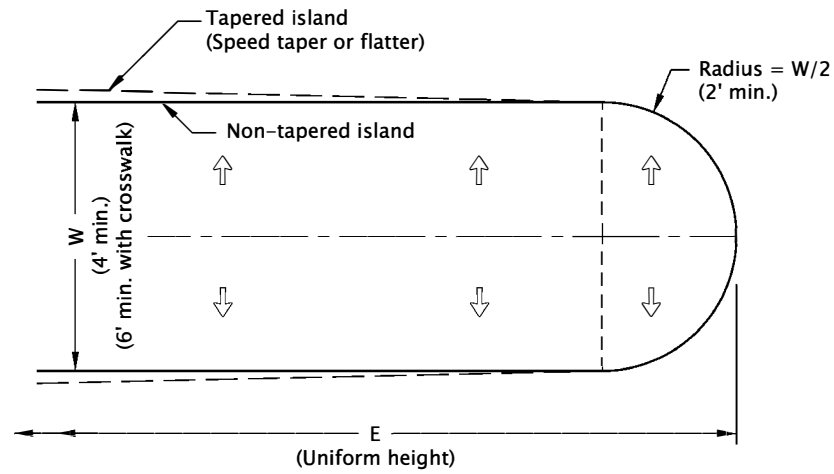
ELEVATION



ELEVATION

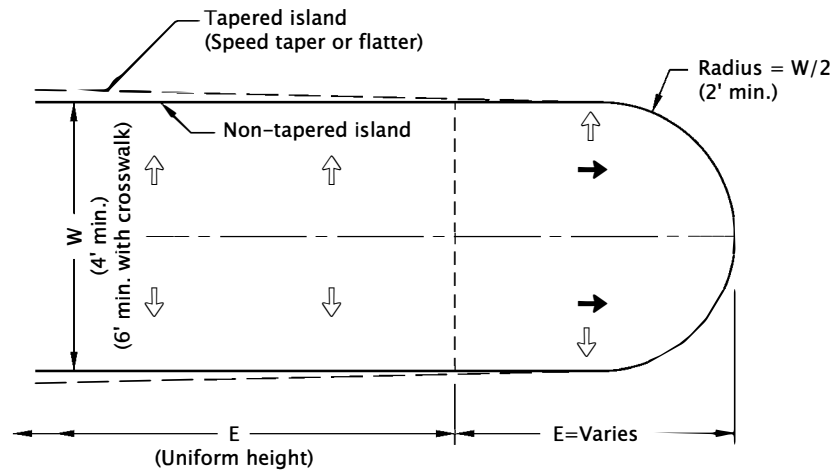


ELEVATION



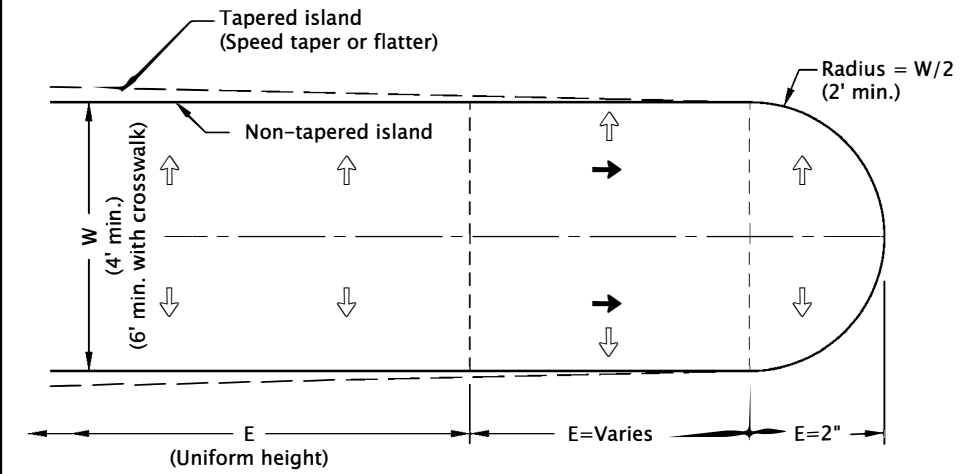
PLAN

OPTION "A"



PLAN

OPTION "B"



PLAN

OPTION "C"

GENERAL NOTES FOR ALL DETAILS ON THIS SHEET:

1. Curb type and median width as shown on plans or as directed.
2. Curb exposure "E" = 6" normal. Vary as shown on plans or as directed.
3. Standard batter is shown. Vary as shown on typical section or as directed.
4. See Std. Dwgs. RD700, RD701, RD705, RD706 & RD710 for additional details.
5. Site conditions normally require a project specific design, which considers roadway conditions (sheet flow limits, cross slope, superelevation, profile, pavement type, lane and shoulder widths, etc.).
6. See Std. Dwg. RD710 for accessible route islands.

- ↗ Slope (2.0% normal)
- Slope (varies)
- E Curb exposure

CALC. BOOK NO. N/A

SDR DATE 22-JUL-2016

NOTE: All material and workmanship shall be in accordance with the current City of The Dalles Standard Specifications

CITY OF THE DALLES STANDARD DRAWINGS

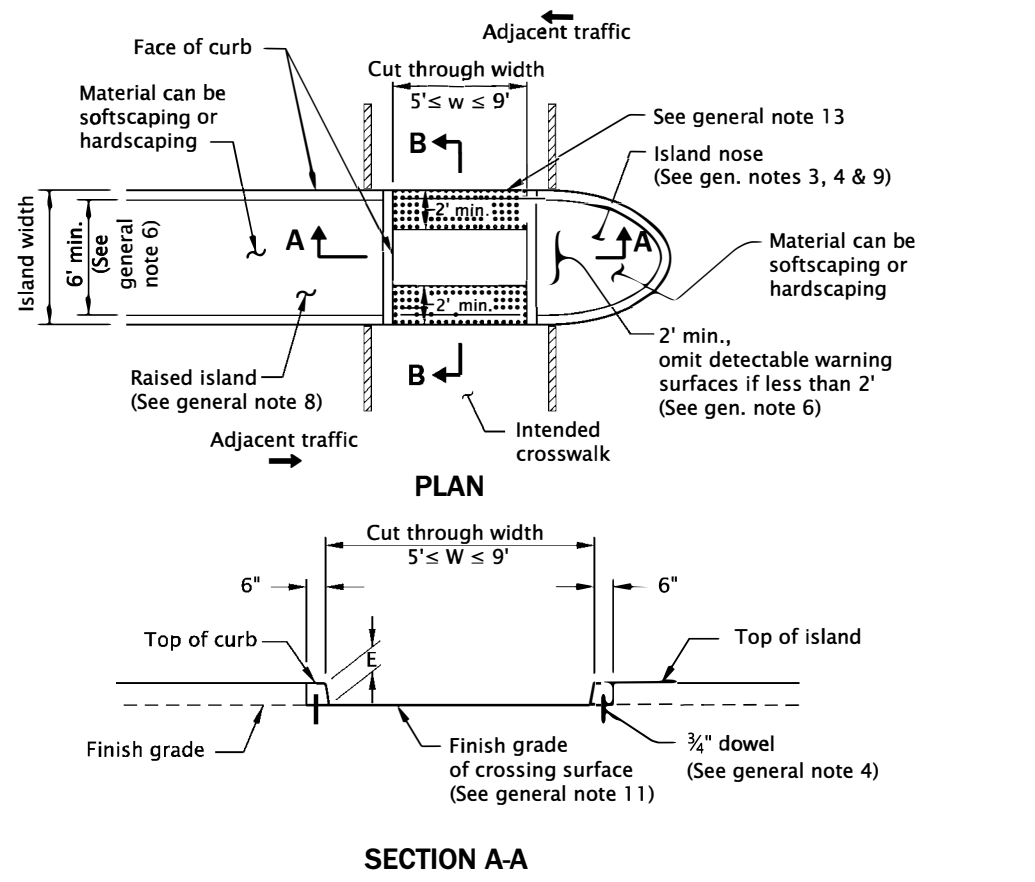
ISLAND NOSE TREATMENTS

2025

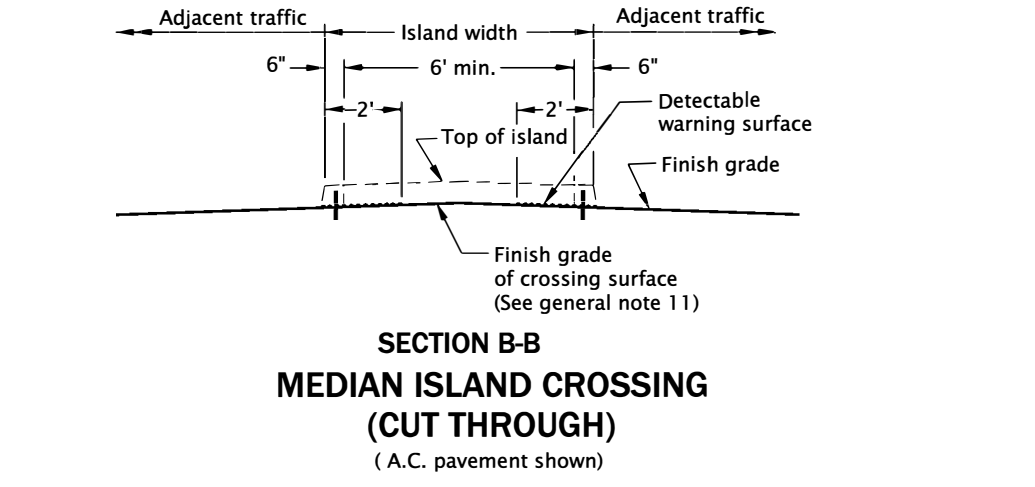
DATE	REVISION DESCRIPTION

The selection and use of this Standard Drawing, while designed in accordance with generally accepted engineering principles and practices, is the sole responsibility of the user and should not be used without consulting a Registered Professional Engineer.

rd710.dgn 19-JUL-2021

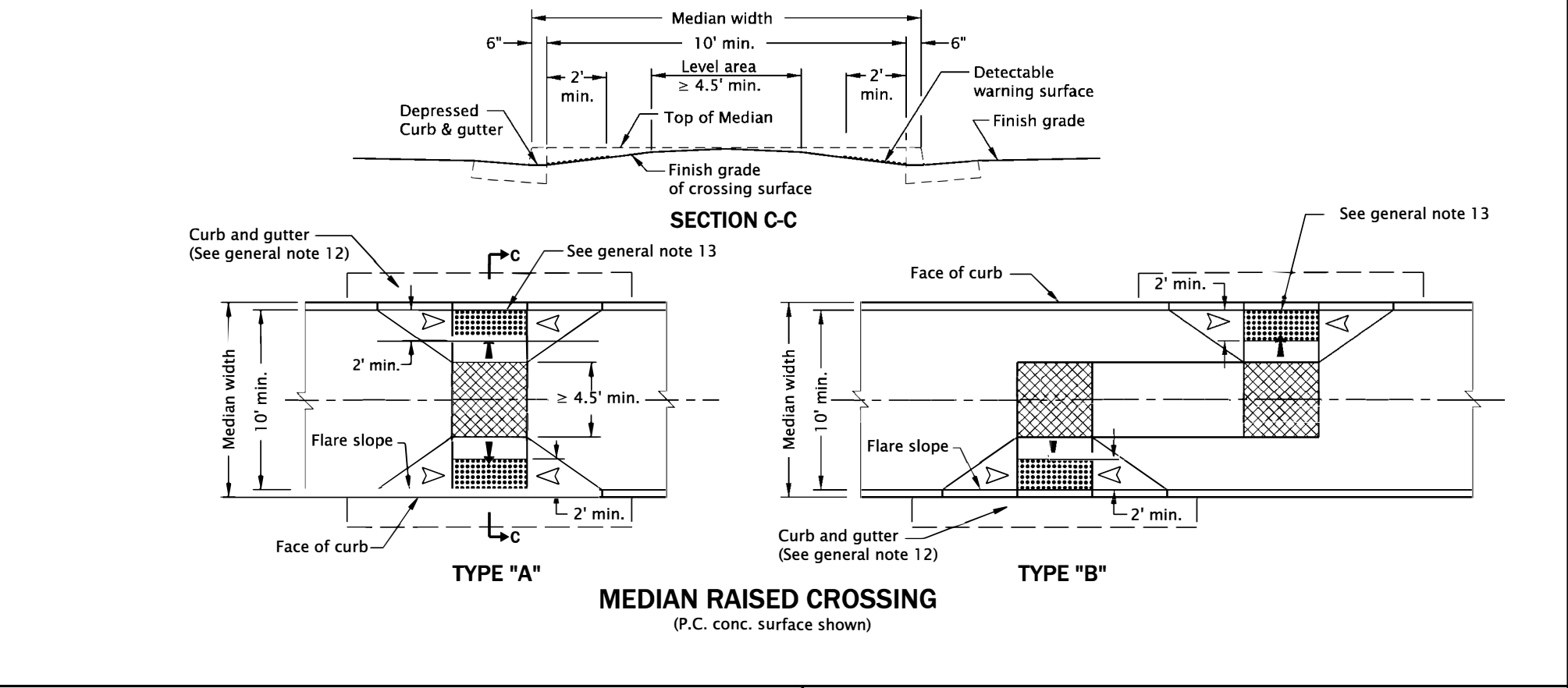


SECTION A-A

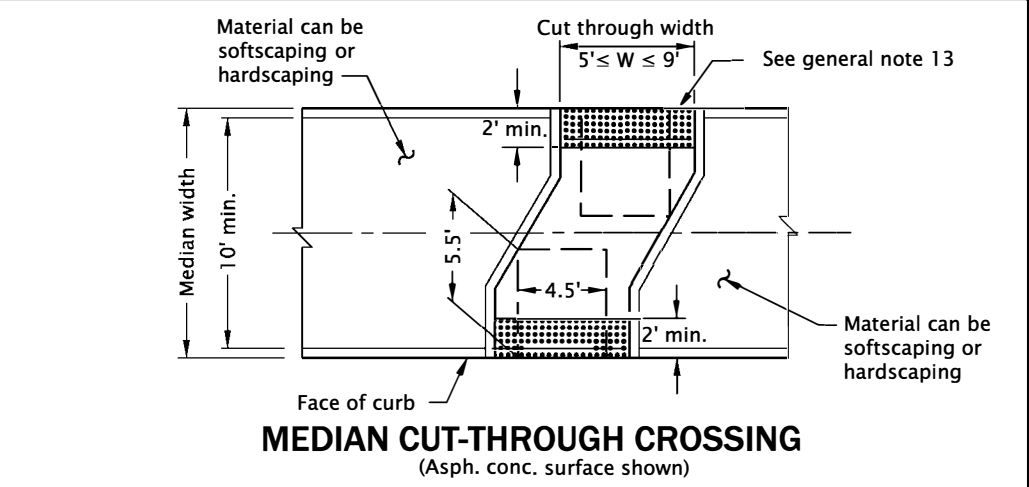


SECTION B-B
MEDIAN ISLAND CROSSING
(CUT THROUGH)
(A.C. pavement shown)

- GENERAL NOTES FOR ALL DETAILS ON THIS SHEET:**
1. Accessible route islands are based on applicable ODOT Standards.
 2. Place detectable warning surface at the back of curb for a minimum depth of 2 feet at curb ramp that is adjacent to traffic. For details not shown, see Std. Dwgs. RD902 through RD908.
 3. The minimum area of islands that contain signal poles, pedestals, etc., shall be 75 square feet. Square feet to be measured to outer perimeter of entire island.
 4. For cut through islands, dowel each island segment to the pavement with a minimum of two 3/4" diameter dowels. Dowel the nose section of the raised median island with a minimum of two 3/4" diameter dowels. Place dowels as directed. See Std. Dwg RD705.
 5. Align curb ramps for lowered or partially lowered island and cut through island with the crosswalk.
 6. Detectable warning surfaces shall be separated by a 2-foot minimum length of walkway without detectable warnings. Where no curb, the detectable warning surface shall be placed at the edge of roadway.



SECTION C-C
TYPE "A"
TYPE "B"
MEDIAN RAISED CROSSING
(P.C. conc. surface shown)



MEDIAN CUT-THROUGH CROSSING
(Asph. conc. surface shown)

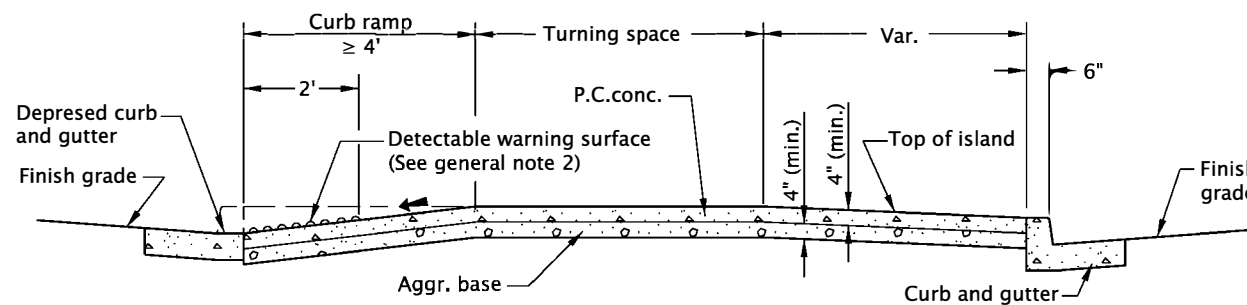
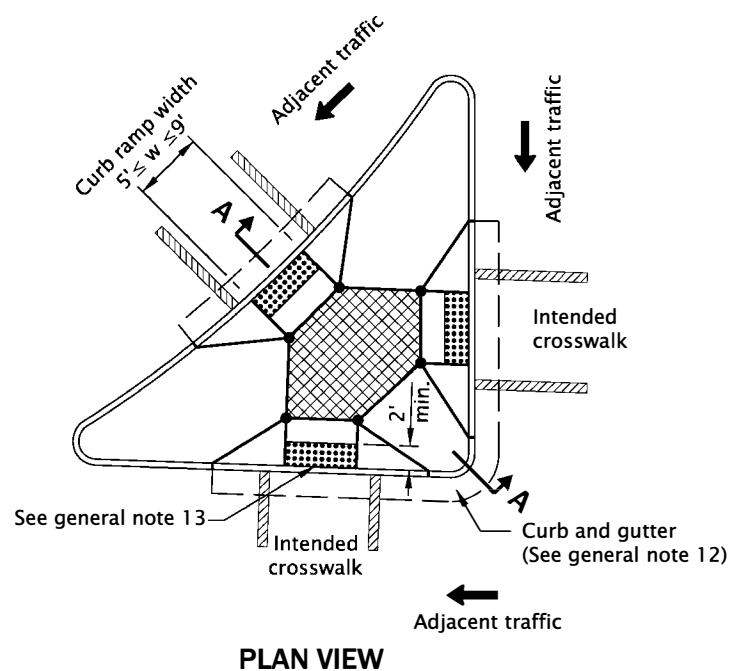
- LEGEND:**
- Marked or intended crossing location
 - Level area (Turning space/landing)
Unobstructed 4.5' x 4.5'
With obstruction 4.5' x 5.5' (Longer dimension in direction of pedestrian street crossing). For the purposes of this application, a max. 2.0% finished surface slope (for drainage) is considered level.
 - Detectable warning surface
 - Cross slope 1.5% max.
(Max. 2.0% finished surface slope)
 - Running slope 7.5% max.
(Max. 8.3% finished surface slope)
 - Flare slope
(Max. 10.0% finished surface slope)
 - Zero curb exposure
 - Clear space 4.5' x 5.5'
(Longer dimension in direction of pedestrian street crossing)

7. Grade breaks at the top and bottom of curb ramp runs shall be perpendicular to the direction of the ramp run. Grade breaks shall not be permitted on the surface of ramp runs and turning spaces. Surface slopes that meet at grade breaks shall be flush.
8. Curb type and island width as shown on plans or as directed.
Type A or Type CA islands are acceptable alternates, see Std. Dwg. RD705.
9. See project plans for details not shown.
See Std. Dwg. RD707 for island nose treatment.
See Std. Dwg. RD705 for expansion and contraction joint spacing.
See Std. Dwgs. RD700, RD701, RD705, RD706 & RD755 for additional details.
See TM Standard Drawings for signal pole, pedestrian pedestal, crosswalk markings, and related details.
10. Details intended for pedestrian route only. For multi-use path, see project plans for specific details.
11. When crossing surface grade is < 5%, a level area is not required.
12. Curb and gutter is required at curb ramps.
13. Raised islands in crossings shall have accessible ramps at both sides or be cut through with the street.

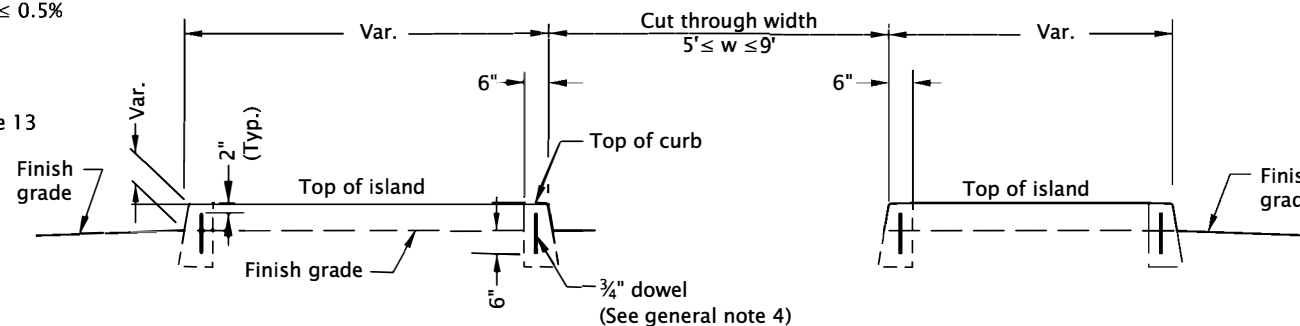
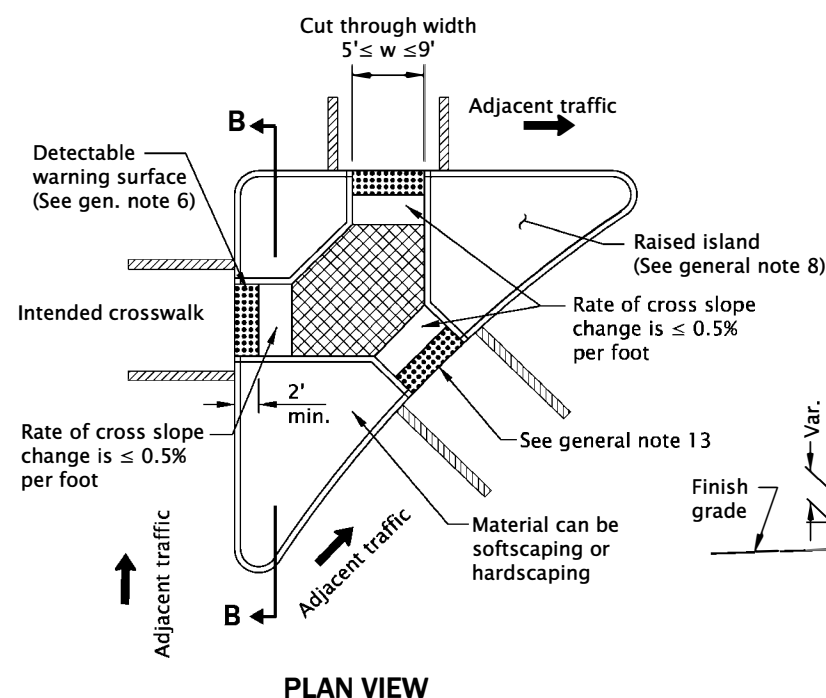
CALC. BOOK NO. <u>N/A</u>		SDR DATE <u>19-JUL-2021</u>	
NOTE: All material and workmanship shall be in accordance with the current City of The Dalles Standard Specifications			
CITY OF THE DALLES STANDARD DRAWINGS			
ACCESSIBLE ROUTE ISLANDS			
2025			
DATE	REVISION	DESCRIPTION	
07-2021		REVISED DETAILS AND NOTES	

The selection and use of this Standard Drawing, while designed in accordance with generally accepted engineering principles and practices, is the sole responsibility of the user and should not be used without consulting a Registered Professional Engineer.

rd711.dgn 19-JUL-2021



SECTION A-A
PARTIALLY LOWERED ISLAND DETAIL
 (Use perpendicular curb ramp inspection form)



SECTION B-B
CUT THROUGH ISLAND DETAIL
RAISED RIGHT TURN CHANNELIZATION ISLAND

GENERAL NOTES FOR ALL DETAILS ON THIS SHEET:

1. Accessible route islands are based on applicable ODOT Standards.
2. Place detectable warning surface at the back of curb for a minimum depth of 2' at curb ramp that is adjacent to traffic. For details not shown, see Std. Dwgs. RD902 through RD908.
3. The min. area of islands that contain signal poles, pedestals, etc., shall be 75 sq. ft. Square feet to be measured to outer perimeter of entire island.
4. For cut through islands dowel each island segment to the pvmt. with a min. of 2, 3#4" dia. dowels. Dowel the nose section of the raised median island with a minimum of 2, 3#4" dia. dowels. Place dowels as directed. See Std. Dwg RD705.
5. Align curb ramps for lowered or partially lowered island and cut through island with the crosswalk.
6. Detectable warning surfaces shall be separated by a 2.0 ft minimum length of walkway without detectable warnings. Where no curb, the detectable warning surface shall be placed at the edge of roadway.
7. Grade breaks at the top and bottom of curb ramp runs shall be perpendicular to the direction of the ramp run. Grade breaks shall not be permitted on the surface of ramp runs and turning spaces. Surface slopes that meet at grade breaks shall be flush.
8. Curb type and island width as shown on plans or as directed.
Type A or Type CA islands are acceptable alternates, see Std. Dwg. RD705.
9. See project plans for details not shown.
See Std. Dwg. RD707 for island nose treatment.
See Std. Dwg. RD705 for expansion and contraction joint spacing.
See Std. Dwgs. RD700, RD701, RD705, RD706 & RD755 for additional details.
See TM Standard Drawings for signal pole, pedestrian pedestal, crosswalk markings, and related details.
10. Details intended for pedestrian route only. For multi-use path, see project plans for specific details.
11. When crossing surface grade is $\pm 5\%$, a level area is not required.
12. Curb and gutter is required at curb ramps.
13. Raised islands in crossings shall have accessible ramps at both sides or be cut through with the street.

LEGEND:

- Marked or intended crossing location
- Level area (Turning space/landing)
Unobstructed 4.5' x 4.5'
With obstruction 4.5' x 5.5' (Longer dimension in direction of pedestrian street crossing).
For the purposes of this application, a max. 2.0% finished surface slope (for drainage) measured perpendicular in two directions is considered level.
- Detectable warning surface
- Cross slope 1.5% max.
(Max. 2.0% finished surface slope)
- Running slope 7.5% max.
(Max. 8.3% finished surface slope)
- Zero curb exposure

CALC. BOOK NO. N/A SDR DATE 19-JUL-2021

NOTE: All material and workmanship shall be in accordance with the current City of The Dalles Standard Specifications

CITY OF THE DALLES STANDARD DRAWINGS

ACCESSIBLE ROUTE CHANNELIZED ISLANDS

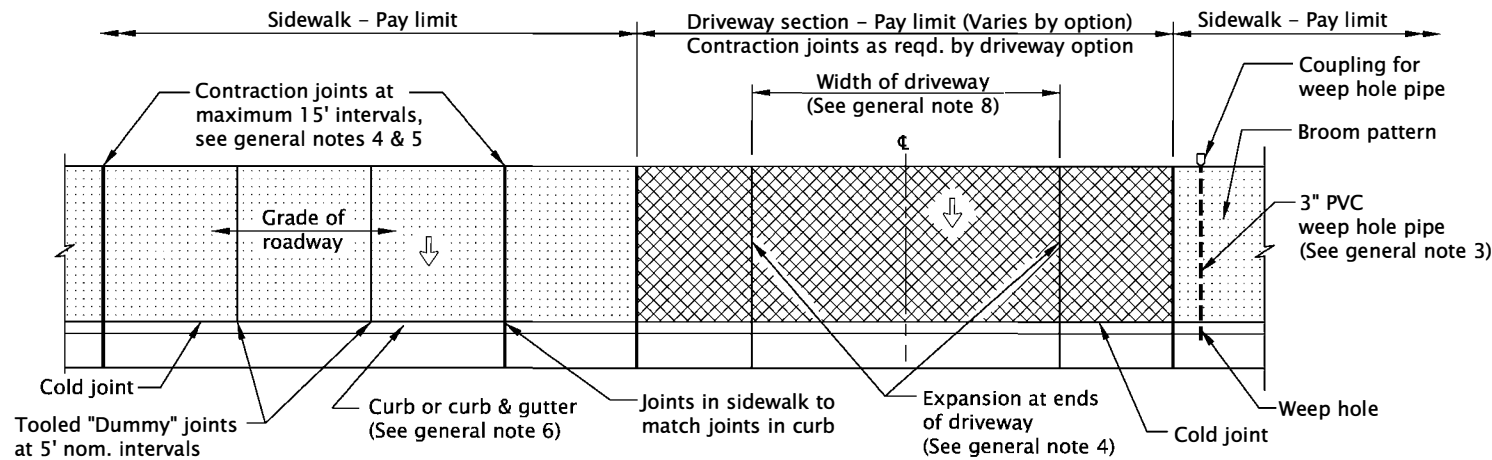
2025

DATE	REVISION	DESCRIPTION
07-2020	DRAWING CREATED	
07-2021	REVISED NOTES	

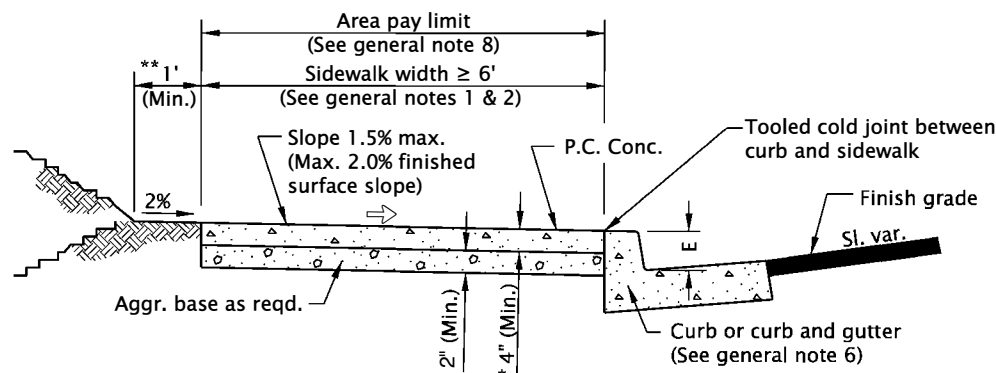
The selection and use of this Standard Drawing, while designed in accordance with generally accepted engineering principles and practices, is the sole responsibility of the user and should not be used without consulting a Registered Professional Engineer.

rd720.dgn 20-JUL-2020

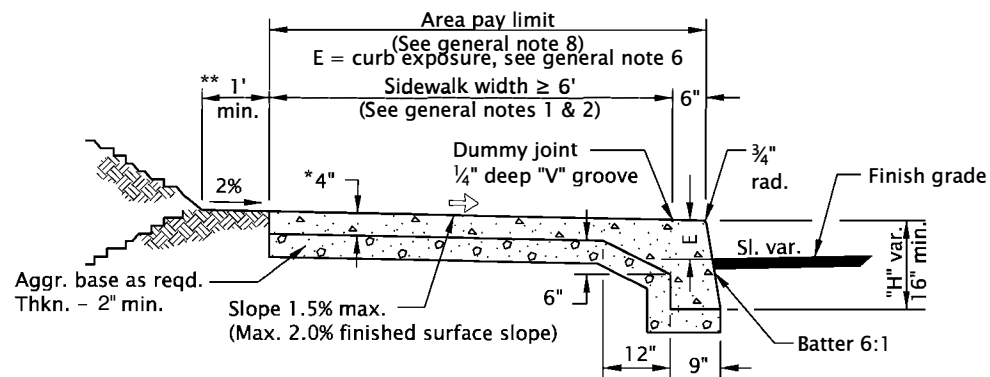
RD720



TYPICAL PLAN VIEW - CURB LINE SIDEWALK



TYPICAL CURB SIDEWALK CROSS SECTION



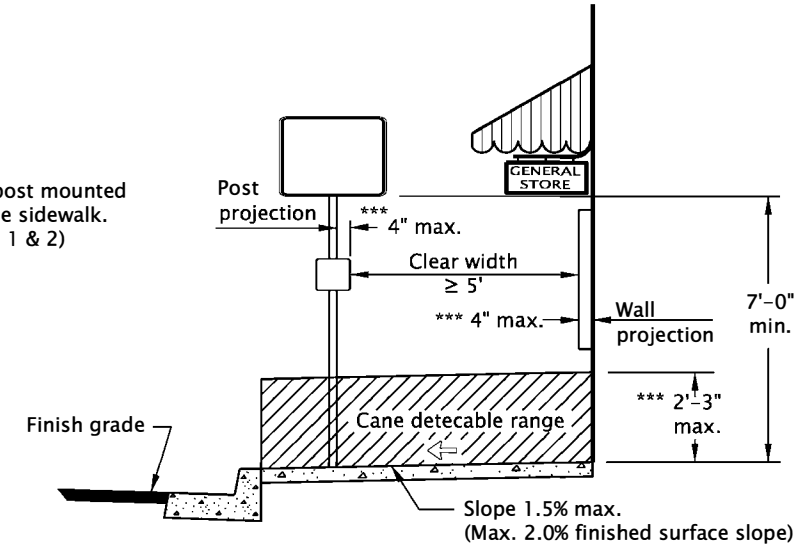
TYPICAL MONOLITHIC CURB & SIDEWALK CROSS SECTION

MUST BE APPROVED BY CITY ENGINEER; E = curb exposure, see general note 6

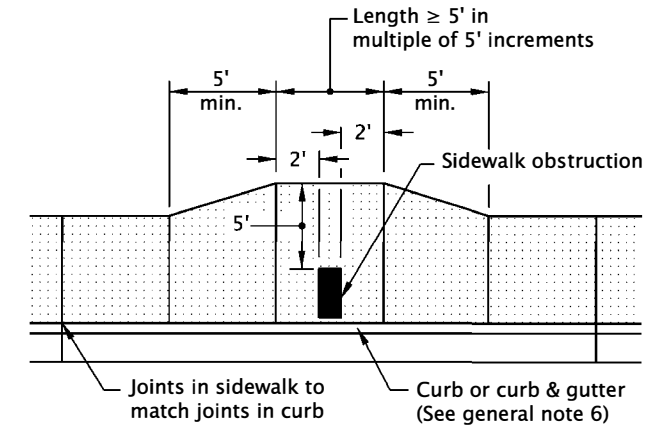
- * Min. 4" or as specified in plans. A thickness ≥ 6 " if sidewalk is intended as portion of a driveway or mountable curb is used.
- ** Provide compacted backfill adjacent to curb and sidewalk

*** Objects with base below 2'-3" may protrude any distance as long as the 5' circulation path is maintained. When an object with a base higher than 2'-3" protrudes further than 4" provide a detection below protrusion to delineate edge.

Building, wall, or post mounted obstruction outside sidewalk. (See general notes 1 & 2)



CLEAR CIRCULATION PATH



REQUIRED SIDEWALK WIDENING AROUND OBSTRUCTIONS

GENERAL NOTES FOR ALL DETAILS ON THIS SHEET:

1. Include additional paved or unpaved 2' shy distance to vertical faces higher than 5' such as retaining walls, sound walls, fences and buildings.
2. Curb type and sidewalk width as shown on plans or as directed. 5' wide sidewalk allowed as infill. On sidewalks 8' and wider, provide a longitudinal joint at the midpoint.
3. Install 3" pvc weep hole pipes in sidewalks where shown on plans, and allowed by jurisdiction. Place contraction joint over top of pipe. See Std. Dwg. RD700 for weep hole details.
4. Provide expansion joints around poles, posts, boxes, at ends of each driveway, and other fixtures which protrude through or against the structures. For sidewalk, monolithic curb & sidewalk, const. expansion joints at 45' maximum spacing. See Std. Dwg. RD722 for expansion joints details.
5. Const. contraction joints at 15' maximum spacing, and at ends of each curb ramp. See Std. Dwg. RD722 for contraction joints details.
6. For curb details, see Std. Dwg. RD700 & RD701. City of The Dalles standard E=6".

7. Sidewalk details are based on applicable ODOT standards.
8. Fully lowered sidewalk shown; see project plans for the driveway design specified. For driveway details not shown, see Std. Dwg. RD725, RD730, RD735, RD740, RD745 & RD750.
9. See project plans for details not shown.

LEGEND

- Sidewalk pay limit.
- Driveway pay limit, varies by option, (See general note 8).
- Cross slope 1.5% max. (Max. 2.0% finished surface slope) (Normal sidewalk cross slope)

CALC. BOOK NO. N/A

SDR DATE 21-JUN-2019

NOTE: All material and workmanship shall be in accordance with the current City of The Dalles Standard Specifications

CITY OF THE DALLES STANDARD DRAWINGS

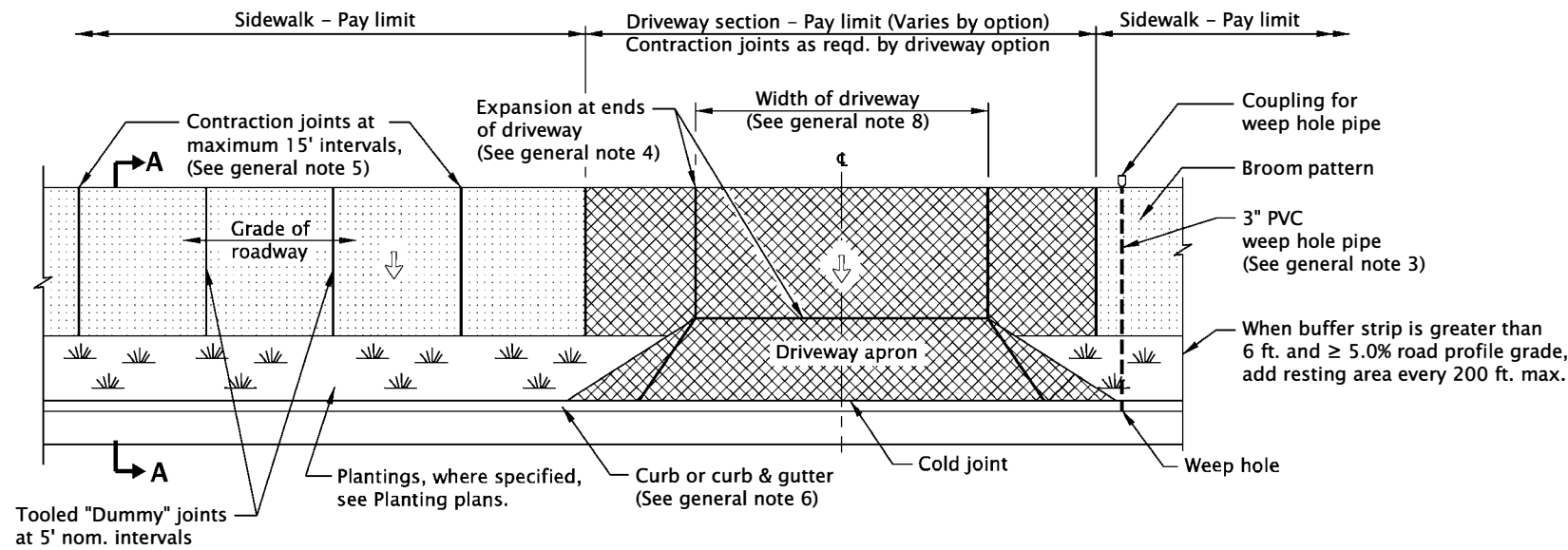
CURB LINE SIDEWALKS

2025

DATE	REVISION DESCRIPTION

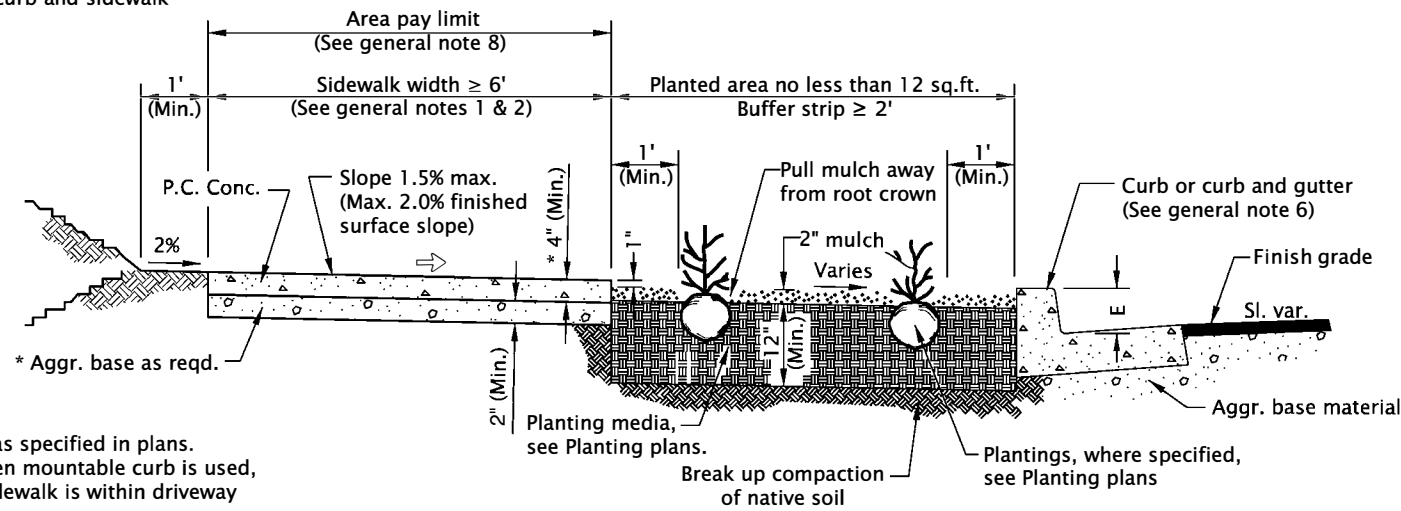
The selection and use of this Standard Drawing, while designed in accordance with generally accepted engineering principles and practices, is the sole responsibility of the user and should not be used without consulting a Registered Professional Engineer.

rd721.dgn 20-JUL-2020



TYPICAL PLAN VIEW - SEPARATED SIDEWALK

Provide compacted backfill adjacent to curb and sidewalk



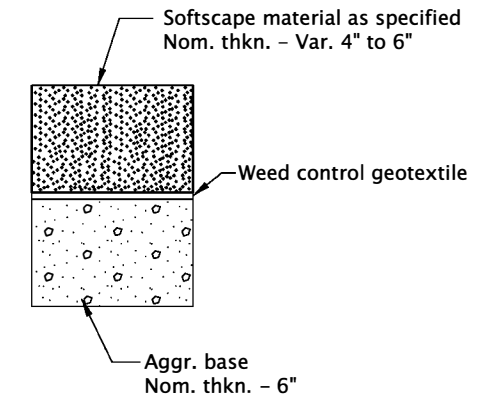
SECTION A-A

TYPICAL SETBACK SIDEWALK CROSS SECTION

E = curb exposure, see general note 6

GENERAL NOTES FOR ALL DETAILS ON THIS SHEET:

1. Include additional paved or unpaved 2' shy distance to vertical faces higher than 5' such as retaining walls, sound walls, fences and buildings.
2. Curb type and sidewalk width as shown on plans or as directed. 5' sidewalk width allowed as infill. On sidewalks 8' and wider, provide a longitudinal joint at the midpoint.
3. Install 3" pvc weep hole pipes in sidewalks where shown on plans, and allowed by jurisdiction. Place contraction joint over top of pipe. See Std. Dwg. RD700 for weep hole details.
4. Provide expansion joints around poles, posts, boxes, at ends of each driveway, and other fixtures which protrude through or against the structures. For sidewalk, monolithic curb & sidewalk, const. expansion joints at 45' maximum spacing. See Std. Dwg. RD722 for expansion joint details.
5. Const. contraction joints at 15' maximum spacing, and at ends of each curb ramp. See Std. Dwg. RD722 for contraction joint details.
6. Curb and gutter shown; see project plans for the curb design specified. For curb details, see Std. Dwgs. RD700 & RD701. City of The Dalles standard E=6".
7. Sidewalk details are based on ODOT applicable standards.
8. Driveway encroaches into sidewalk shown; see project plans for the driveway design specified. For driveway details not shown, see Std. Dwgs. RD725, RD730, RD735, RD740, RD745 & RD750.
9. See project plans for details not shown.
10. Provide plantings in areas 12 SF or greater, as shown or directed. Treat areas less than 12 SF with mulch surfacing.



NON-PLANTED SOFTSCAPE CROSS SECTION

NOTES:

1. Use softscape materials allowed by jurisdiction.
2. Approved softscape materials:
 - a) Loose, durable round rock 2"-4" in diameter
 - b) Lava rock 2"-4" diameter
 - c) Wood chips/bark mulch
 - d) Sand
3. No crushed aggregate or pea gravel allowed.
4. Install softscape material flush with the top of sidewalk.

LEGEND

- Sidewalk pay limit.
- Driveway pay limit, varies by option, (See general note 8).
- Cross slope 1.5% max. (Max. 2.0% finished surface slope) (Normal sidewalk cross slope)

CALC. BOOK NO. N/A

SDR DATE 20-JUL-2020

NOTE: All material and workmanship shall be in accordance with the current City of The Dalles Standard Specifications

CITY OF THE DALLES STANDARD DRAWINGS

SEPARATED SIDEWALKS

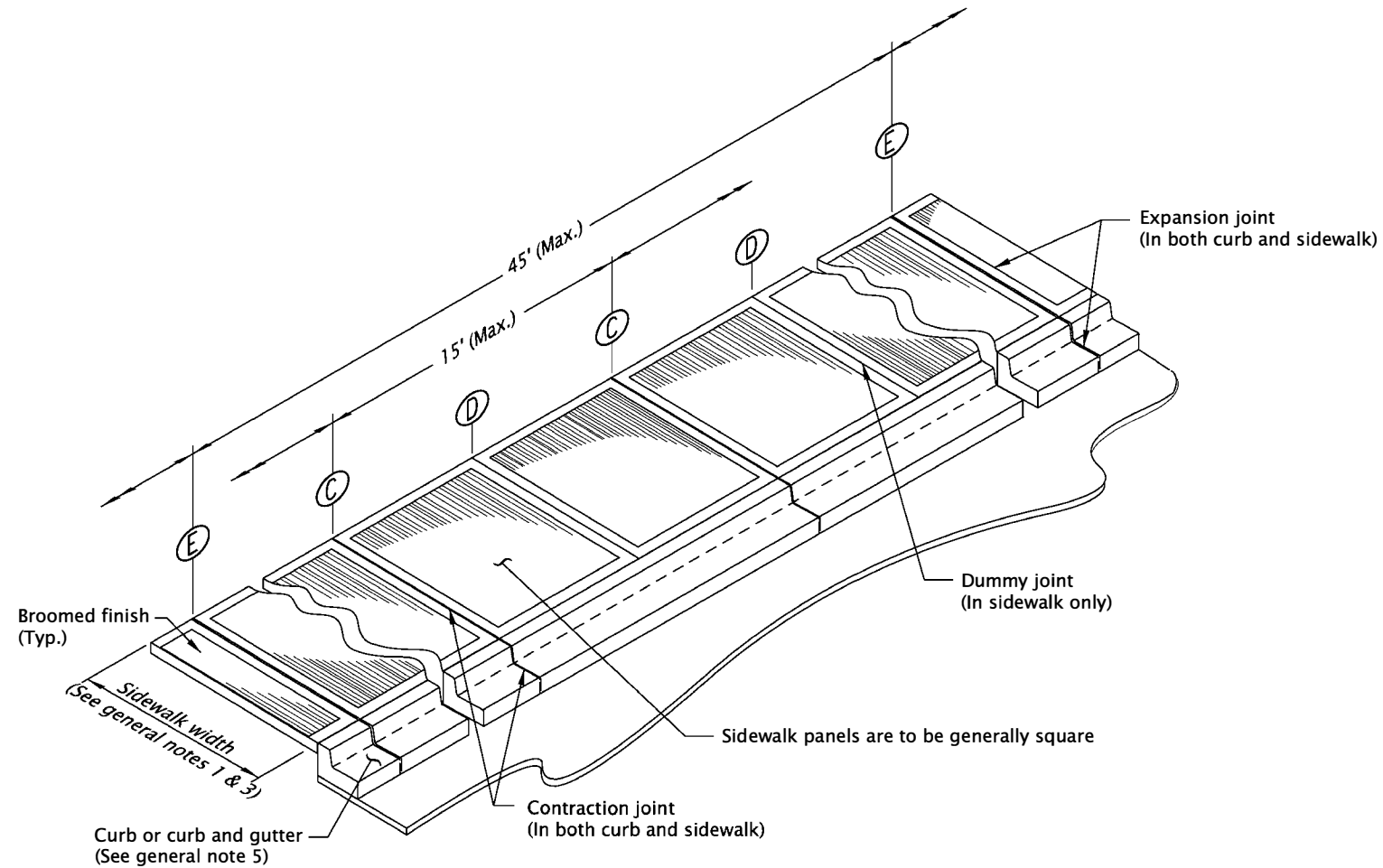
2025

DATE	REVISION DESCRIPTION

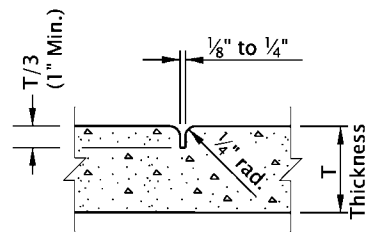
The selection and use of this Standard Drawing, while designed in accordance with generally accepted engineering principles and practices, is the sole responsibility of the user and should not be used without consulting a Registered Professional Engineer.

RD721

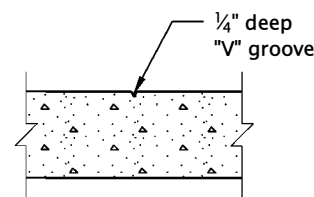
rd722.dgn 20-JUL-2020



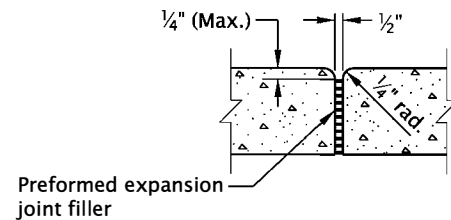
JOINT DETAIL
(Curb line sidewalk with curb and gutter shown)



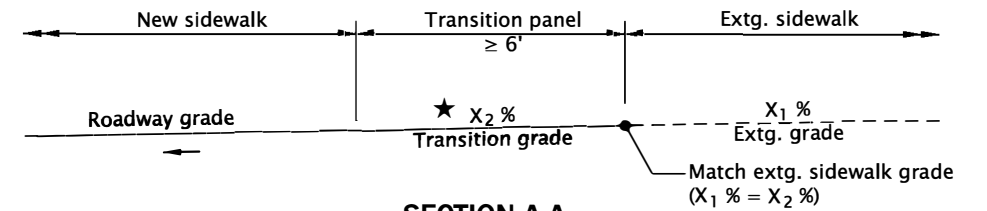
C CONTRACTION JOINT
(See general note 6)



D DUMMY JOINT

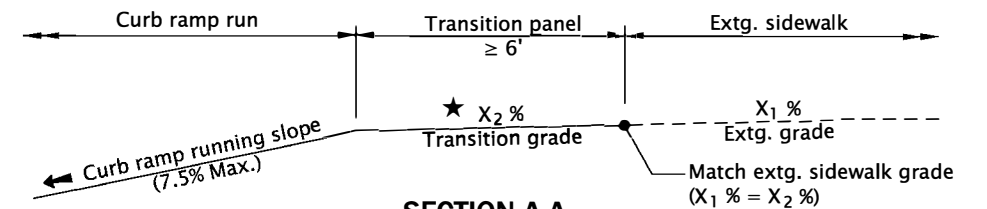


E EXPANSION JOINT
(See general notes 2 & 5)

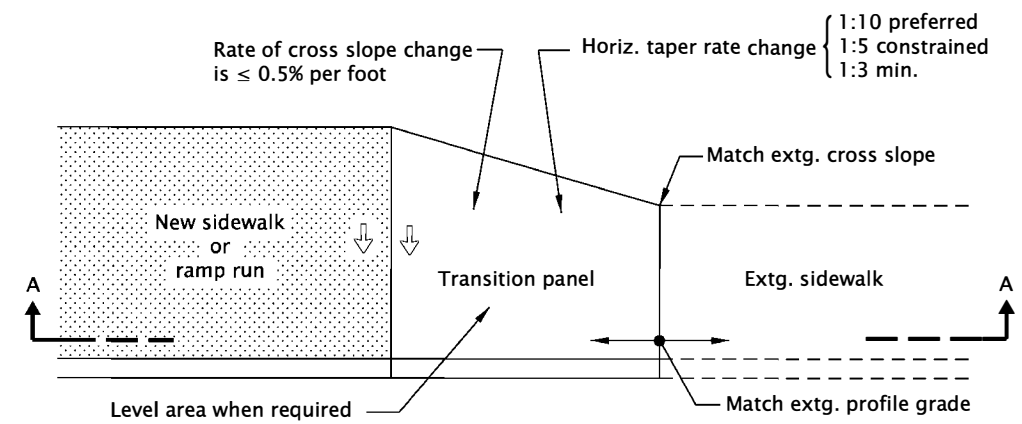


SECTION A-A
(SIDEWALK TRANSITION PANEL SHOWN)

★ Project the existing sidewalk profile grade through transition panel to new sidewalk or curb ramp run.



SECTION A-A
(CURB RAMP TRANSITION PANEL SHOWN)



PLAN
SIDEWALK AND CURB RAMP TRANSITION PANELS

GENERAL NOTES FOR ALL DETAILS ON THIS SHEET:

1. See Std. Dwgs. RD720 & RD721 for concrete sidewalk details. See project plans for sidewalk width, placement and design specified.
2. Provide expansion joints around poles, boxes, at ends of each driveway and other fixtures which protrude through or against the structures. For sidewalk, monolithic curb and sidewalk, construction expansion joints at 45' max. spacing.
3. On sidewalks 8' and wider, provide a longitudinal joint at the midpoint of sidewalk panel.
4. See Std. Dwgs. RD700 & RD701 for concrete curb details. See project plans for the curb design specified.
5. For curb ramps, do not place expansion joints within the limits of curb ramps and between separate concrete pours.
6. Const. contraction joints at 15' max. spacing, and at each curb ramp, driveway, sidewalk and curb.

LEGEND:

- New sidewalk or ramp run
- Slope 1.5% max. (Max. 2.0% finished surface slope) (Normal sidewalk cross slope)
- Slope 7.5% max. (Max. 8.3% finished surface slope)
- Zero exposure

CALC. BOOK NO. N/A

SDR DATE 20-JUL-2020

NOTE: All material and workmanship shall be in accordance with the current City of The Dalles Standard Specifications

CITY OF THE DALLES STANDARD DRAWINGS

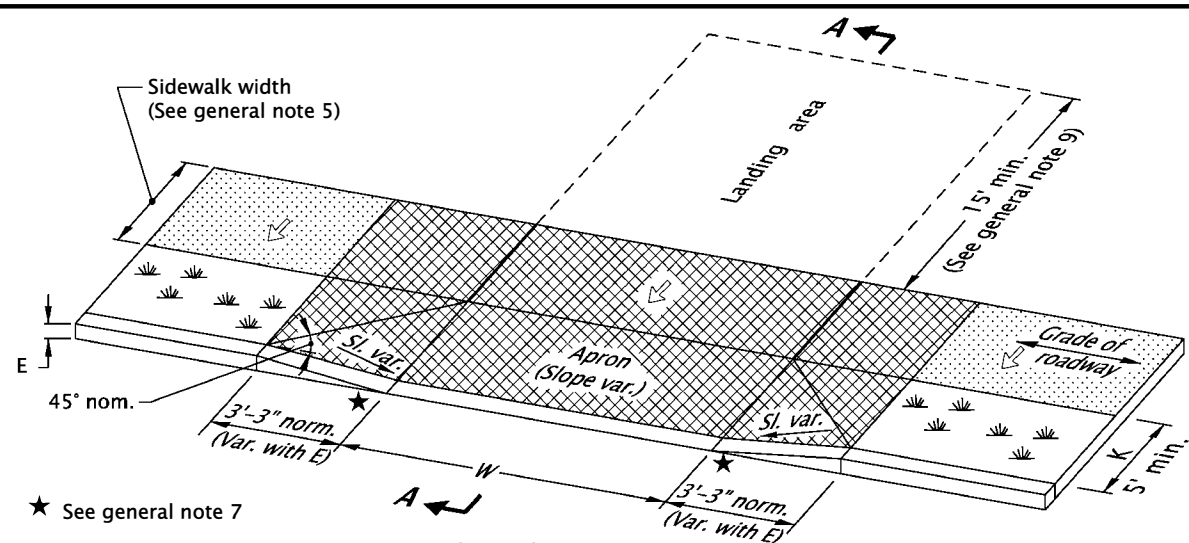
SIDEWALK JOINTS AND TRANSITION PANELS

2025

DATE	REVISION	DESCRIPTION

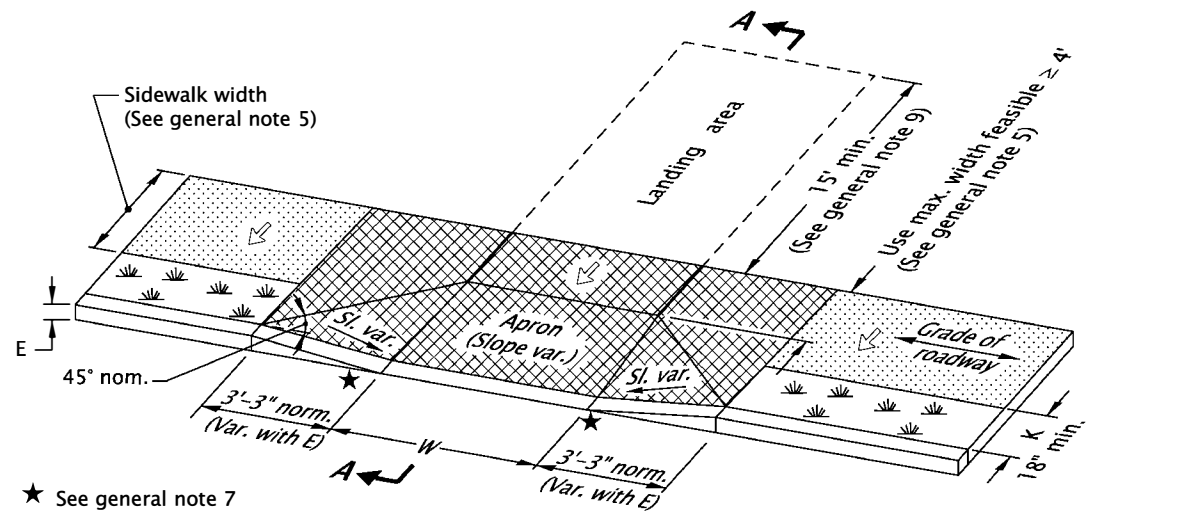
RD722

rd740.dgn 20-JUL-2020

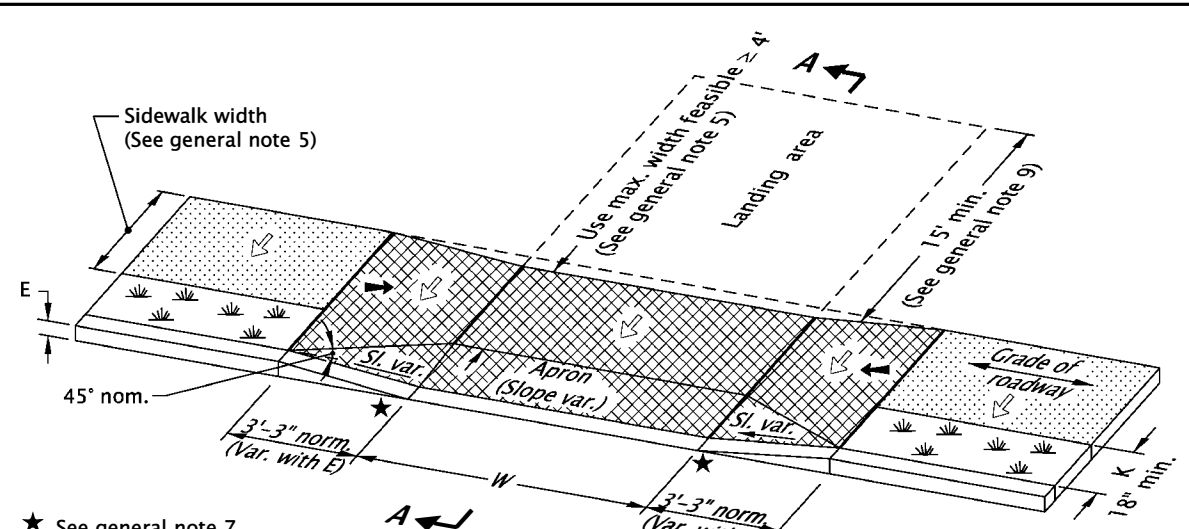


**OPTION H
TYPICAL SEPARATED SIDEWALK DRIVEWAY**

(Use one of the options below if slope requirements shown in Section A-A cannot be met)



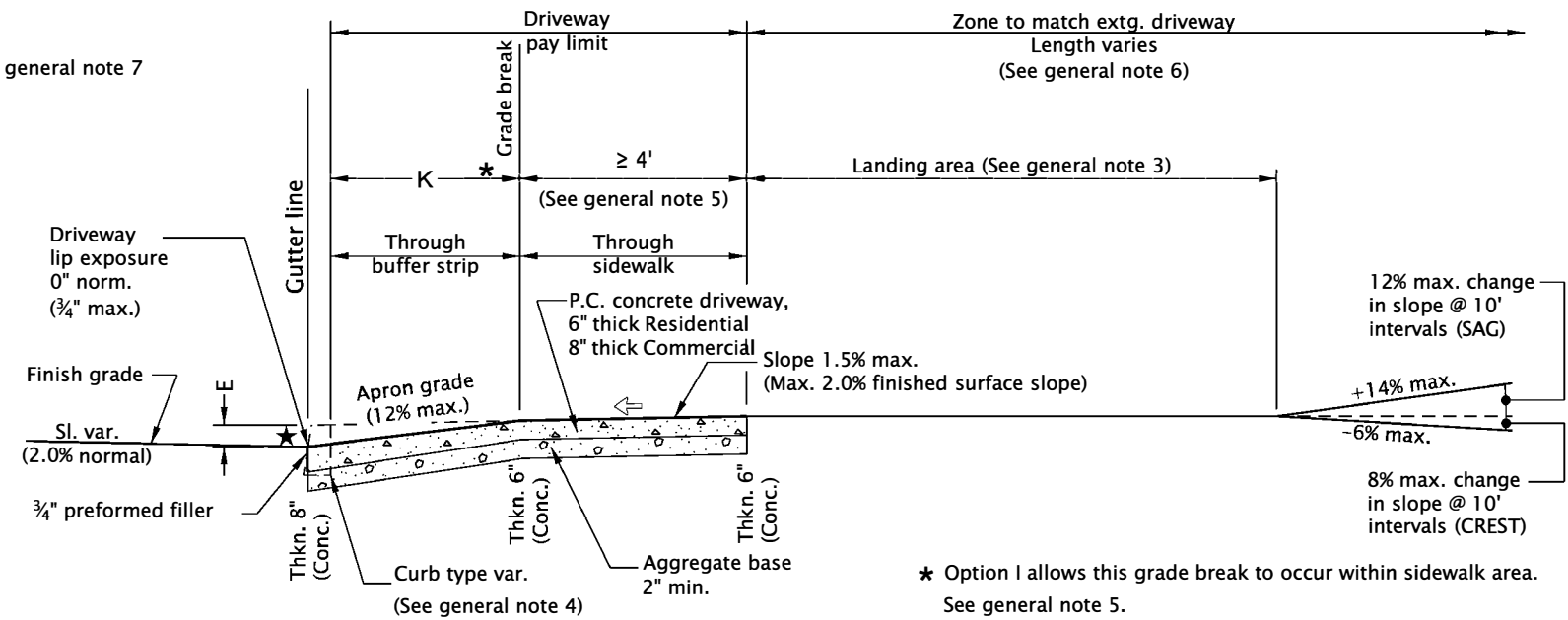
**OPTION I
DRIVEWAY ENCLOSES INTO SIDEWALK**



**OPTION J
LOWERED SIDEWALK**

RD740

★ See general note 7



SECTION A-A

GENERAL NOTES FOR ALL DETAILS ON THIS SHEET:

1. Details are based on applicable ODOT Standards.
2. Only use details approved by City.
3. The following dimensions are as shown on plans, or as directed: driveway width, driveway slope, sidewalk width, buffer strip width, curb exposure, driveway lip exposure, landing area length and width. See project plans for details not shown.
4. Curb, gutter, and sidewalk types varies, see plans. See Std. Dwgs. RD700 & RD701 for curb details. See Std. Dwg. RD721 for sidewalk details. See Std. Dwg. RD722 for joint details.
5. A greater than or equal 4' unobstructed clear passage with cross slope 1.5% max. (Max. 2.0% finished surface slope) is required behind driveway apron.
6. Where existing driveway is in good condition, and meets slope requirements, construct only as much landing area as required for satisfactory connection with new work.
7. Check the gutter flow depth at driveway locations to assure that the design flood does not overtop the back of sidewalk at driveway. If overtopping occurs place an inlet at upstream side of driveway or perform other approved design mitigation.
8. Construct a full depth expansion joints with 1#2" (In) preformed joint filler at ends of each driveway. Tooled joints are required at all driveway slope break lines.
9. 15' min. of the driveway behind the sidewalk should be surfaced to prevent tracking of gravel onto the sidewalk.

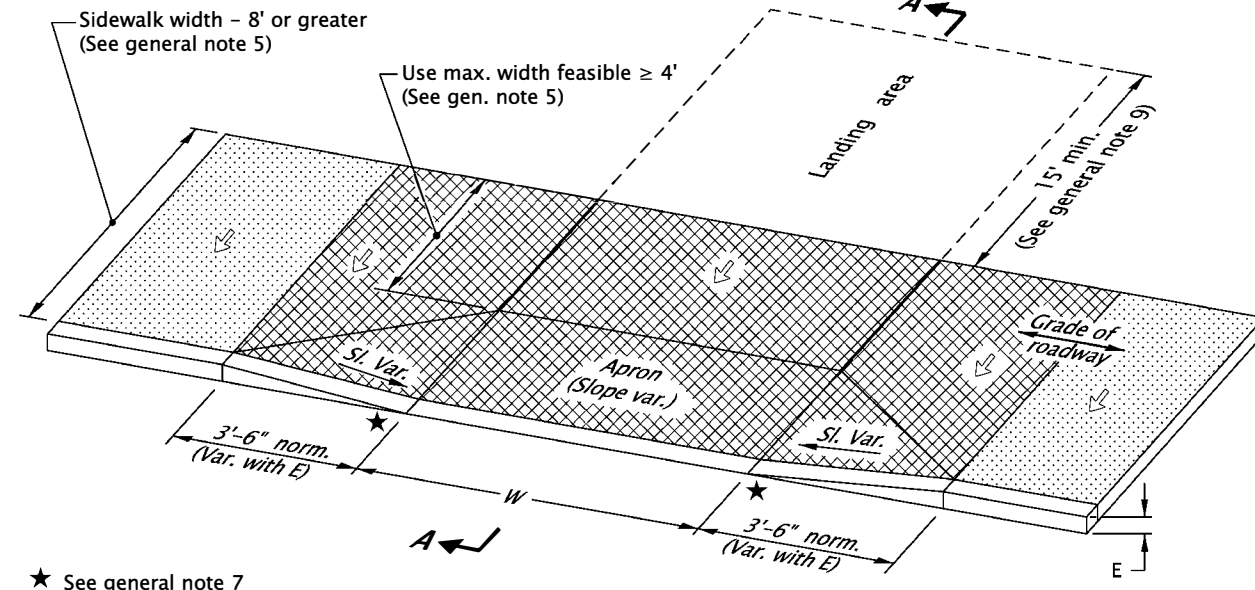
LEGEND:

- Sidewalk
- Driveway pay limit (See project plans for details not shown)
- Cross slope 1.5% max. (Max. 2.0% finished surface slope) (Normal sidewalk cross slope)
- Running slope 7.5% max. (Max. 8.3% finished surface slope)

- W Width of driveway
- K Buffer strip width
- E Curb exposure

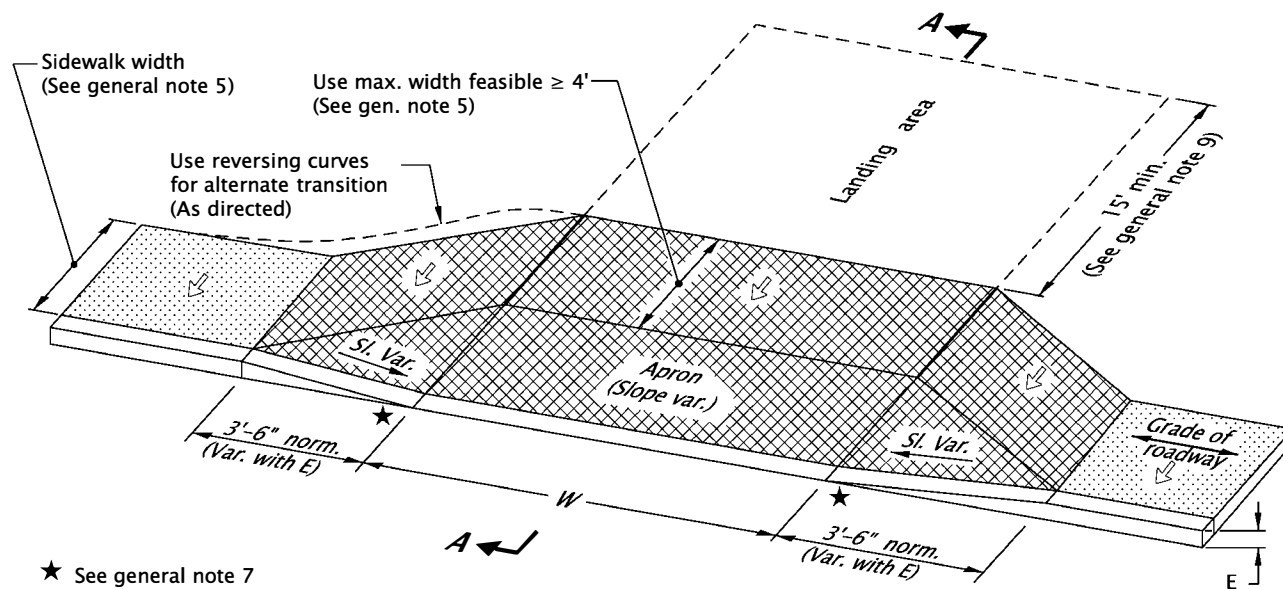
CALC. BOOK NO. <u>N/A</u>	SDR DATE <u>20-JUL-2020</u>
NOTE: All material and workmanship shall be in accordance with the current City of The Dalles Standard Specifications	
CITY OF THE DALLES STANDARD DRAWINGS	
SEPARATED SIDEWALK DRIVEWAYS OR ALLEYS (OPTIONS H, I & J)	
2025	
DATE	REVISION DESCRIPTION

The selection and use of this Standard Drawing, while designed in accordance with generally accepted engineering principles and practices, is the sole responsibility of the user and should not be used without consulting a Registered Professional Engineer.



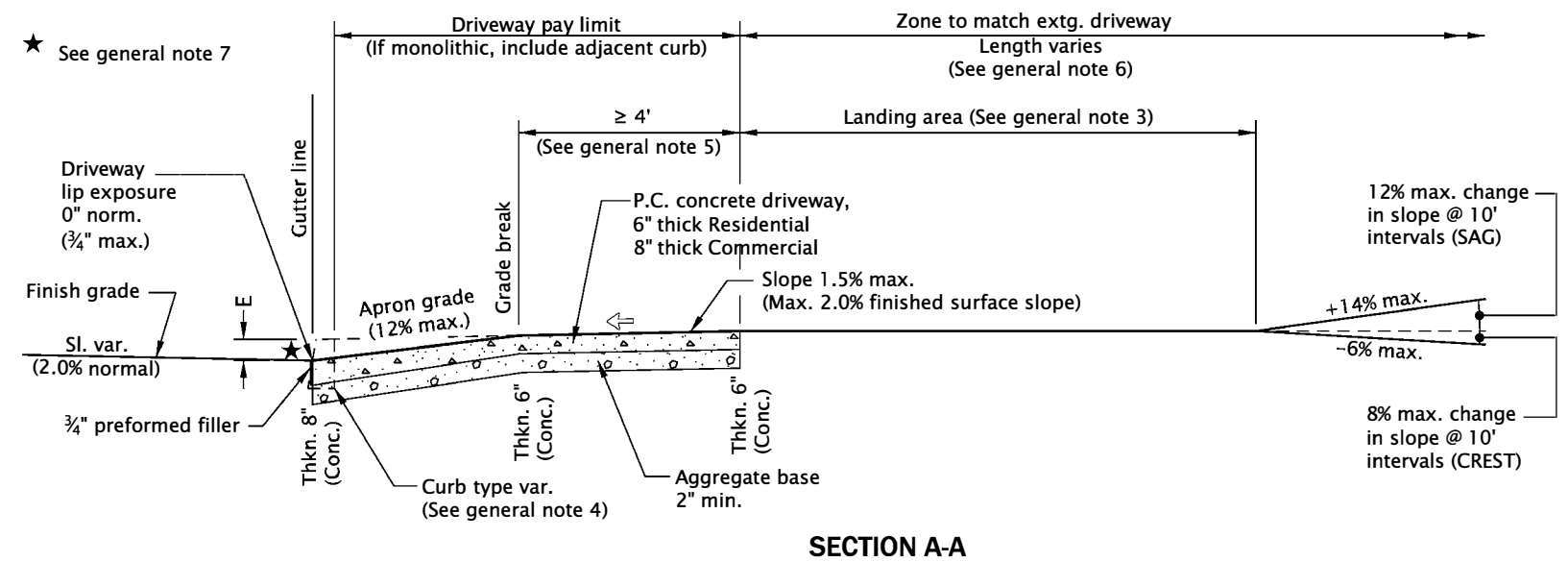
★ See general note 7

**OPTION K
DRIVEWAY IN WIDE (8' OR GREATER) SIDEWALK**



★ See general note 7

**OPTION L
SIDEWALK WRAPPED AROUND DRIVEWAY**



SECTION A-A

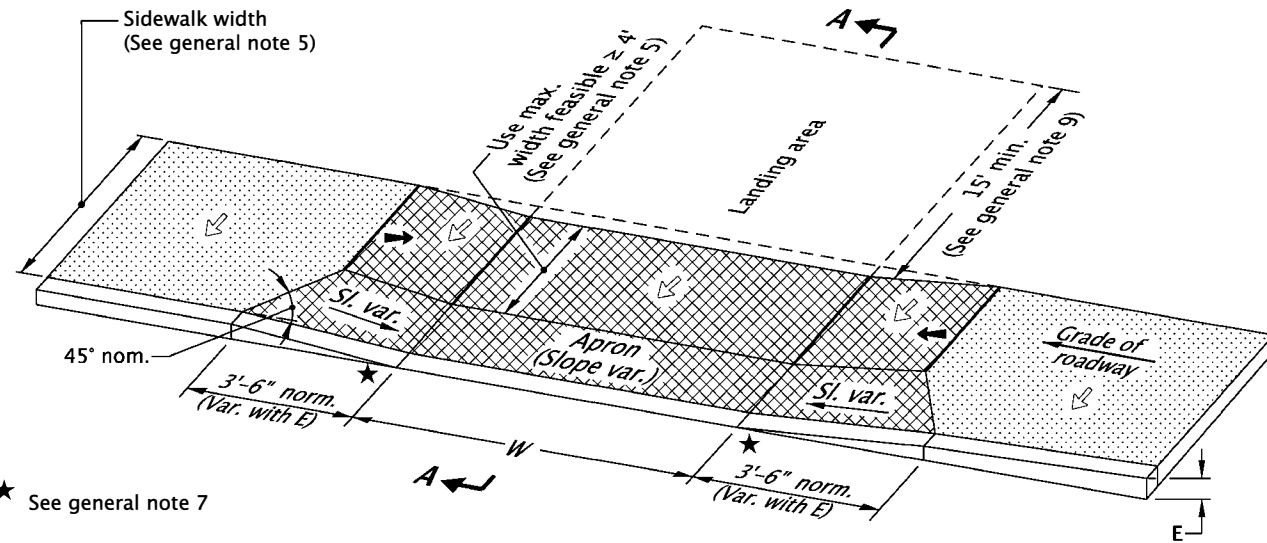
GENERAL NOTES FOR ALL DETAILS ON THIS SHEET:

- Details are based on applicable ODOT Standards.
- Only use details approved by City.
- The following dimensions are as shown on plans, or as directed: driveway width, driveway slope, sidewalk width, curb exposure, driveway lip exposure, landing area length and width. See project plans for details not shown.
- Curb, gutter, and sidewalk types varies, see plans. See Std. Dwg. RD700 & RD701 for curb details. See Std. Dwg. RD720 for sidewalk details. See Std. Dwg. RD722 for joint details.
- A greater than or equal 4' unobstructed clear passage with cross slope 1.5% max. (Max. 2.0% finished surface slope) is required behind driveway apron.
- Where existing driveway is in good condition, and meets slope requirements, construct only as much landing area as required for satisfactory connection with new work.
- Check the gutter flow depth at driveway locations to assure that the design flood does not overtop the back of sidewalk at driveway. If overtopping occurs place an inlet at upstream side of driveway or perform other approved design mitigation.
- Construct a full depth expansion joints with 1/2" preformed joint filler at ends of each driveway. Tooled joints are required at all driveway slope break lines.
- 15' min. of the driveway behind the sidewalk should be surfaced to prevent tracking of gravel onto the sidewalk.
- Monolithic curb & sidewalk shall retain thickened edge through lowered profile, to accommodate driveway use. See Std. Dwg. RD720 for details.

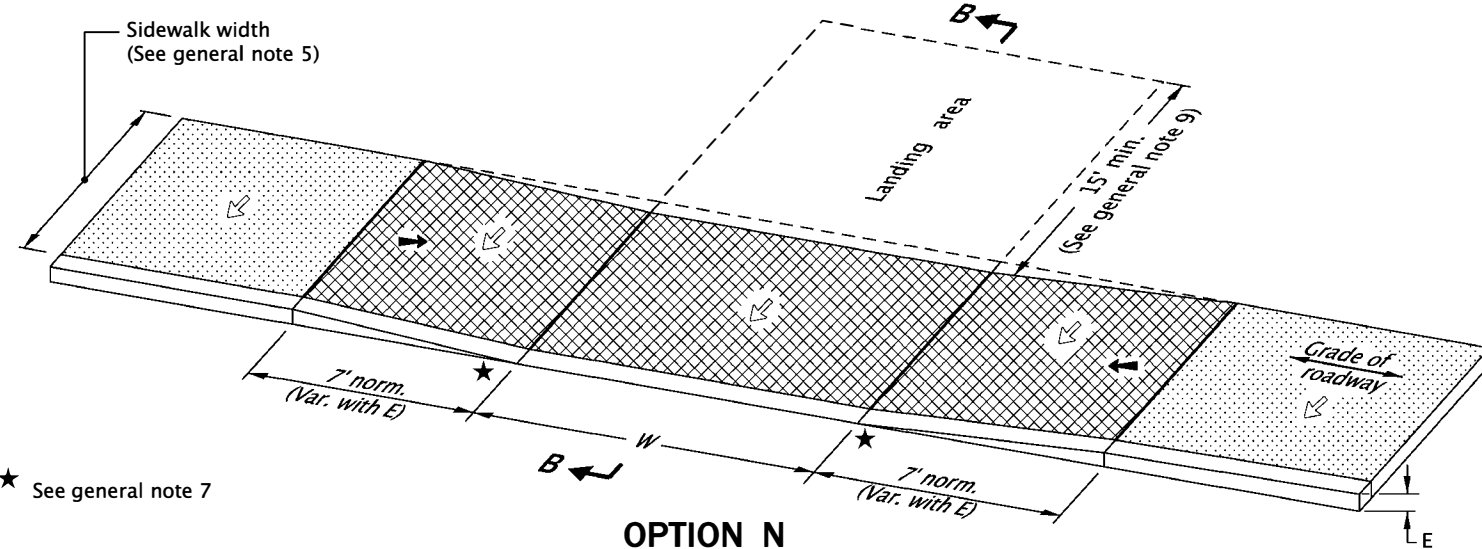
LEGEND:

- Sidewalk
- Driveway pay limit (If monolithic, include adjacent curb) (See project plans for details not shown)
- Cross slope 1.5% max. (Max. 2.0% finished surface slope) (Normal sidewalk cross slope)
- W** Width of driveway
- E** Curb exposure

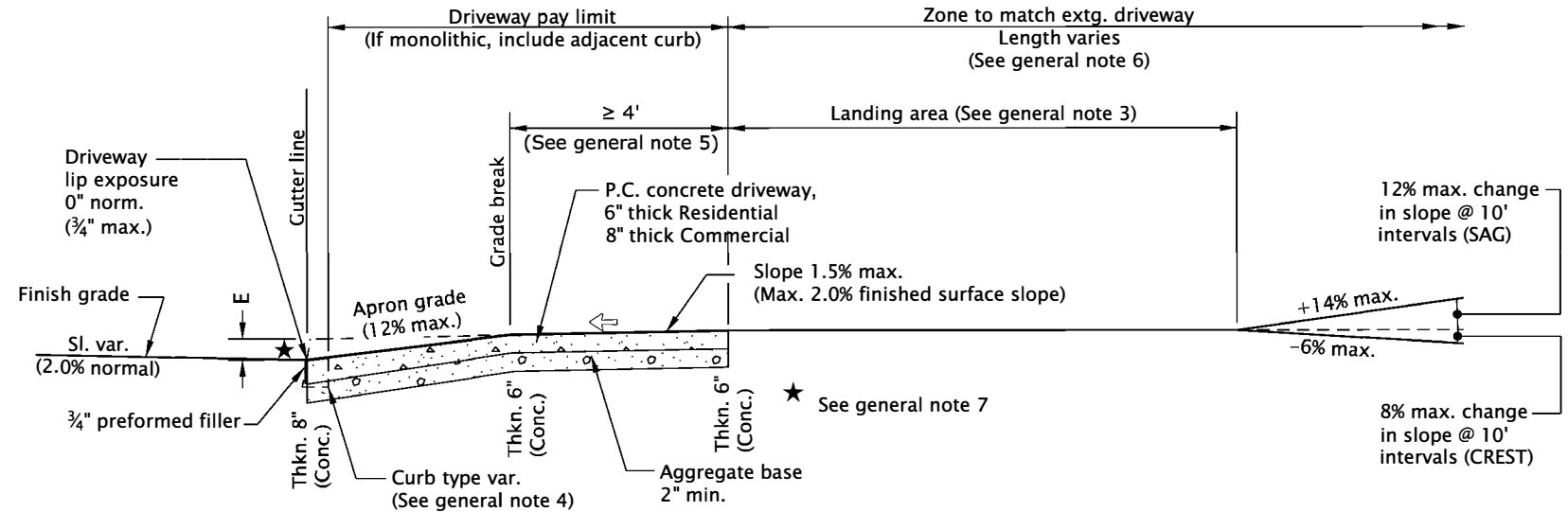
CALC. BOOK NO.	N/A	SDR DATE	19-JUL-2021
<p><i>The selection and use of this Standard Drawing, while designed in accordance with generally accepted engineering principles and practices, is the sole responsibility of the user and should not be used without consulting a Registered Professional Engineer.</i></p>		NOTE: All material and workmanship shall be in accordance with the current City of The Dalles Standard Specifications	
		<p>CITY OF THE DALLES STANDARD DRAWINGS</p> <p>CURB LINE SIDEWALK DRIVEWAYS OR ALLEYS (OPTIONS K & L)</p> <p>2025</p>	
DATE	07-2021	REVISION	REVISION DESCRIPTION



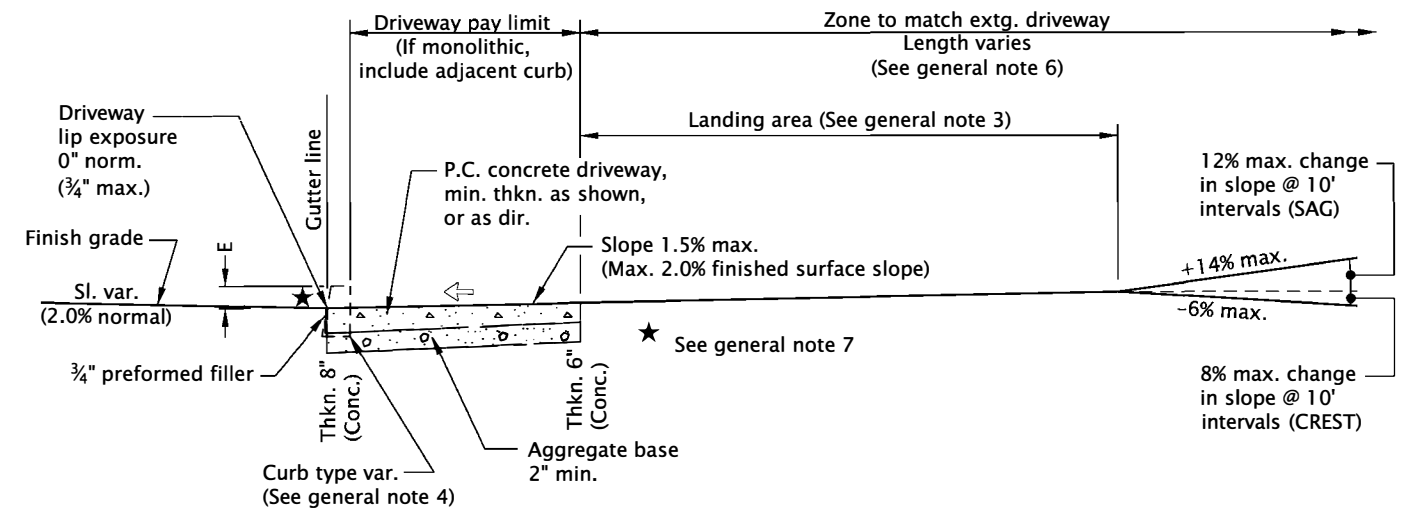
**OPTION M
PARTIALLY LOWERED SIDEWALK**



**OPTION N
FULLY LOWERED SIDEWALK**



SECTION A-A



SECTION B-B

GENERAL NOTES FOR ALL DETAILS ON THIS SHEET:

- Details are based on applicable ODOT Standards.
- Only use details approved by City.
- The following dimensions are as shown on plans, or as directed: driveway width, driveway slope, sidewalk width, curb exposure, driveway lip exposure, landing area length and width. See project plans for details not shown.
- Curb, gutter, and sidewalk types varies, see plans. See Std. Dwgs. RD700 & RD701 for curb details. See Std. Dwg. RD720 for sidewalk details. See Std. Dwg. RD722 for joint details.
- A greater than or equal 4' unobstructed clear passage with cross slope 1.5% max. (Max. 2.0% finished surface slope) is required behind driveway apron.
- Where existing driveway is in good condition, and meets slope requirements, construct only as much landing area as required for satisfactory connection with new work.
- Check the gutter flow depth at driveway locations to assure that the design flood does not overtop the back of sidewalk at driveway. If overtopping occurs place an inlet at upstream side of driveway or perform other approved design mitigation.
- Construct a full depth expansion joints with 1#2" (In) preformed joint filler at ends of each driveway. Tooled joints are required at all driveway slope break lines.
- 15' min. of the driveway behind the sidewalk should be surfaced to prevent tracking of gravel onto the sidewalk.
- Monolithic curb & sidewalk shall retain thickened edge through lowered profile, to accommodate driveway use. See Std. Dwg. RD720 for details.

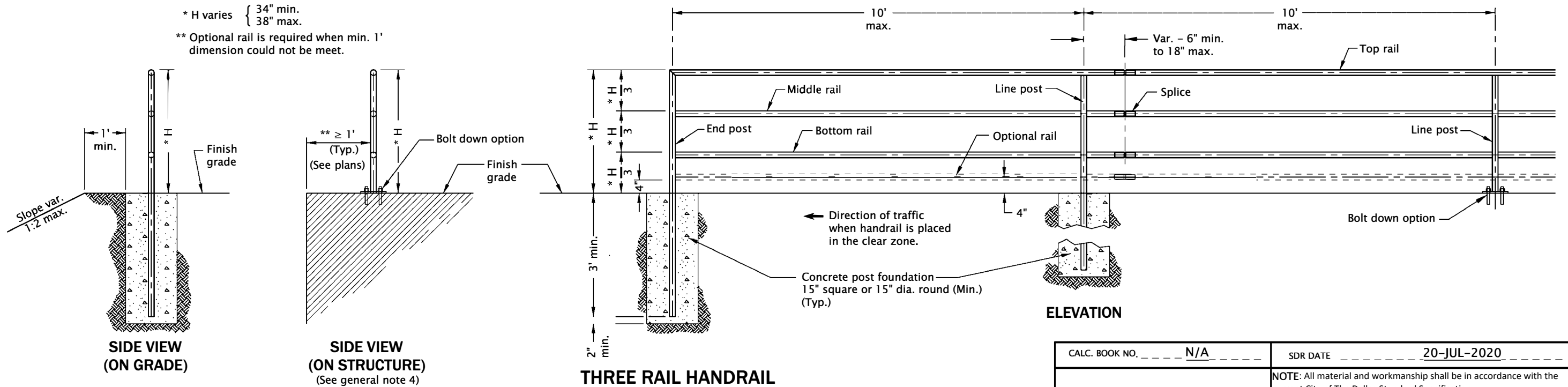
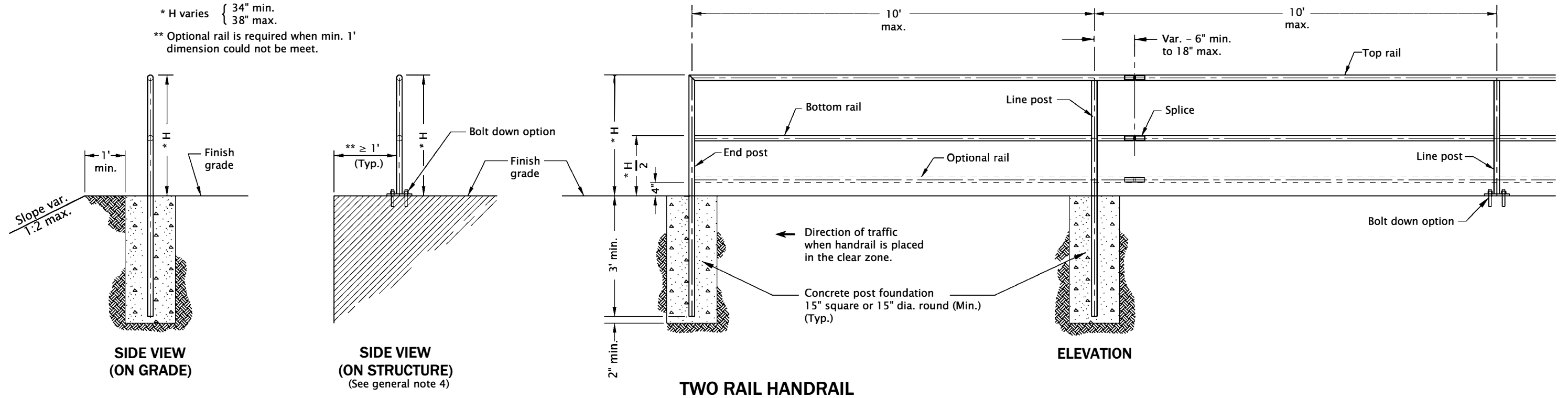
LEGEND:

- Sidewalk
- Driveway pay limit (If monolithic, include adjacent curb) (See project plans for details not shown)
- Cross slope 1.5% max. (Max. 2.0% finished surface slope) (Normal sidewalk cross slope)
- Running slope 7.5% max. (Max. 8.3% finished surface slope)
- W** Width of driveway
- E** Curb exposure

CALC. BOOK NO. <u>N/A</u>	SDR DATE <u>20-JUL-2020</u>
NOTE: All material and workmanship shall be in accordance with the current City of The Dalles Standard Specifications	
CITY OF THE DALLES STANDARD DRAWINGS	
CURB LINE SIDEWALK DRIVEWAYS OR ALLEYS (OPTIONS M & N)	
2025	
DATE	REVISION DESCRIPTION

The selection and use of this Standard Drawing, while designed in accordance with generally accepted engineering principles and practices, is the sole responsibility of the user and should not be used without consulting a Registered Professional Engineer.

rd770.dgn 20-JUL-2020



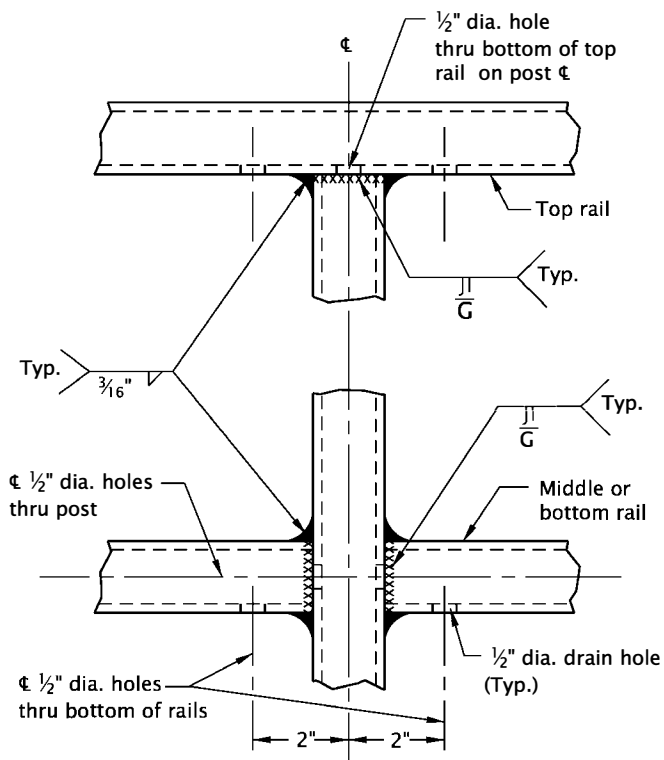
GENERAL NOTES FOR ALL DETAILS ON THIS SHEET:

1. Handrail details are based on applicable ODOT Standards.
2. See Std. Dwg. RD771 for details not shown.
3. Hot-dip galvanize all metal parts after fabrication.
4. Structure varies, see project plans.
5. Handrail height (H) shall be constant within a ramp run or stairway.
6. All concrete shall be commercial grade concrete.
7. See Std. Dwg. RD120 for concrete stairway.
8. See project plans for details not shown.

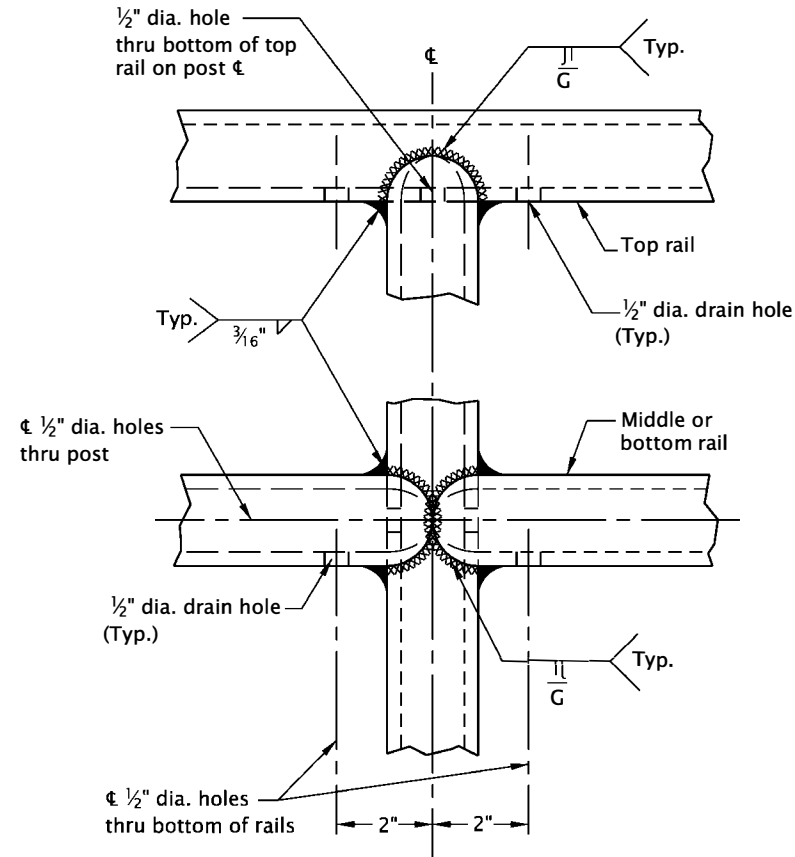
CALC. BOOK NO. <u> N/A </u>	SDR DATE <u> 20-JUL-2020 </u>
NOTE: All material and workmanship shall be in accordance with the current City of The Dalles Standard Specifications	
CITY OF THE DALLES STANDARD DRAWINGS	
METAL HANDRAIL	
2025	
DATE	REVISION DESCRIPTION

The selection and use of this Standard Drawing, while designed in accordance with generally accepted engineering principles and practices, is the sole responsibility of the user and should not be used without consulting a Registered Professional Engineer.

rd771.dgn 20-JUL-2020



WELD DETAILS FOR STEEL TUBING



WELD DETAILS FOR STEEL PIPE

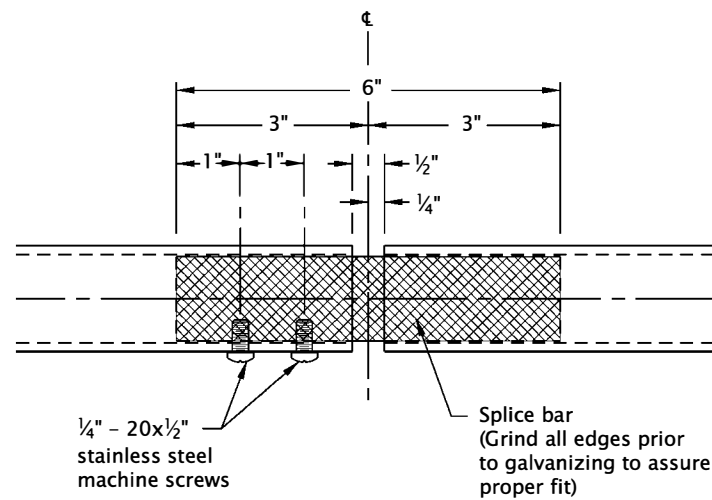
MATERIAL TABLES

STEEL PIPE POST & RAIL MEMBERS				ROUND SPLICE BAR
NOM. DIA.	SCH.	O.D.	I.D.	O.D.
1 1/4"	40	1.660"	1.380"	1 1/4"
1 1/2"	10	1.900"	1.682"	1 1/2"
	40	1.900"	1.610"	

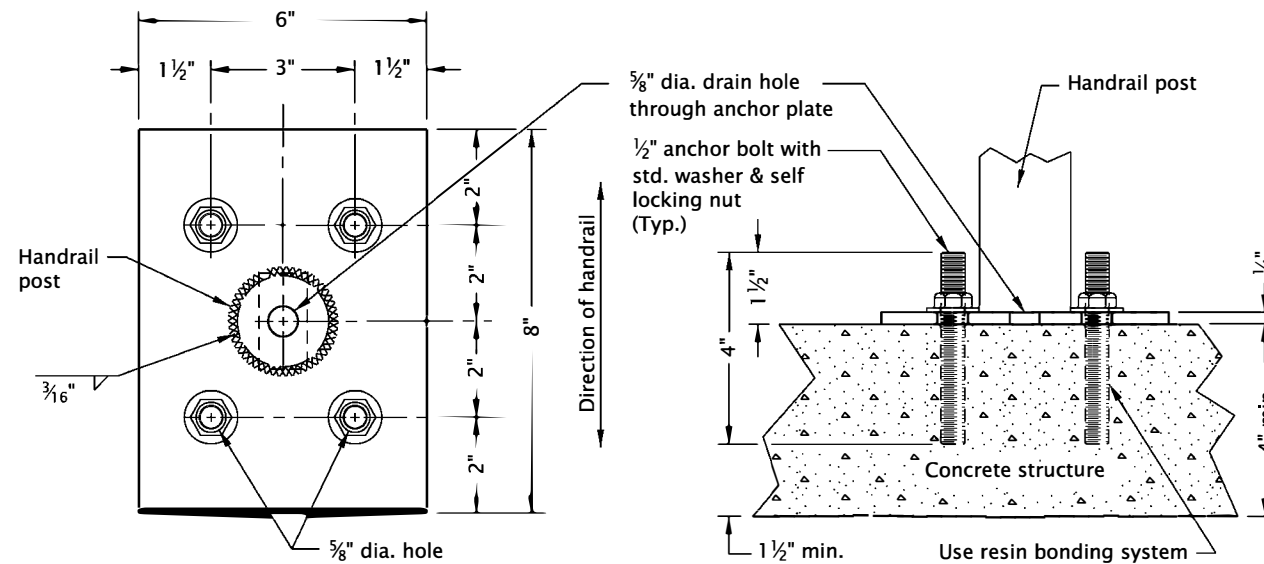
SQUARE STRUCTURAL STEEL TUBING POST & RAIL MEMBERS		SQUARE SPLICE BAR
Outside Dimensions	Wall Thickness	Outside Dimensions
1 1/2"x1 1/2"	1/8"	1"x1"
	3/16"	3/4"x3/4"

GENERAL NOTES FOR ALL DETAILS ON THIS SHEET:

- Handrail details are based on applicable ODOT Standards.
- Select materials from tables. Posts and rails shall be identical material. Structural steel tubing shall conform to ASTM specification A500, grade B.
- Posts shall be vertical. The top rail shall be continuous over a minimum of two posts.
- On structure, the railing shall conform to the vertical alignment of the structure. Rails shall have a splice in the post space occurring at expansion joints.
- On grade, rails shall have splices at intervals not to exceed 100'.
- Hot-dip galvanize all metal parts after fabrication.
- See Std Dwg. RD770 for details not shown.
- See Std Dwg. RD120 for concrete stairway.
- See project plans for details not shown.



SPLICE DETAIL



PLAN VIEW

SIDE VIEW

ANCHOR PLATE FOR BOLT DOWN OPTION

CALC. BOOK NO. N/A

SDR DATE 20-JUL-2020

NOTE: All material and workmanship shall be in accordance with the current City of The Dalles Standard Specifications

CITY OF THE DALLES STANDARD DRAWINGS

METAL HANDRAIL DETAILS

2025

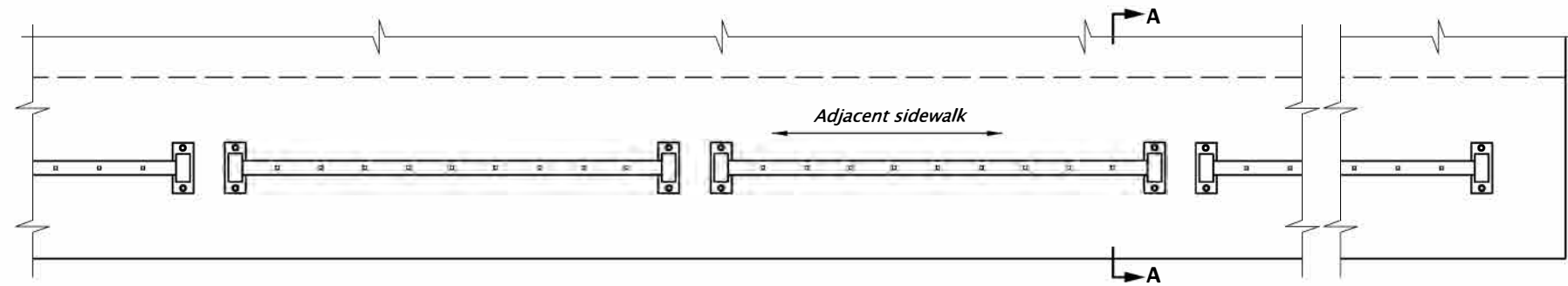
DATE	REVISION	DESCRIPTION

The selection and use of this Standard Drawing, while designed in accordance with generally accepted engineering principles and practices, is the sole responsibility of the user and should not be used without consulting a Registered Professional Engineer.

RD771

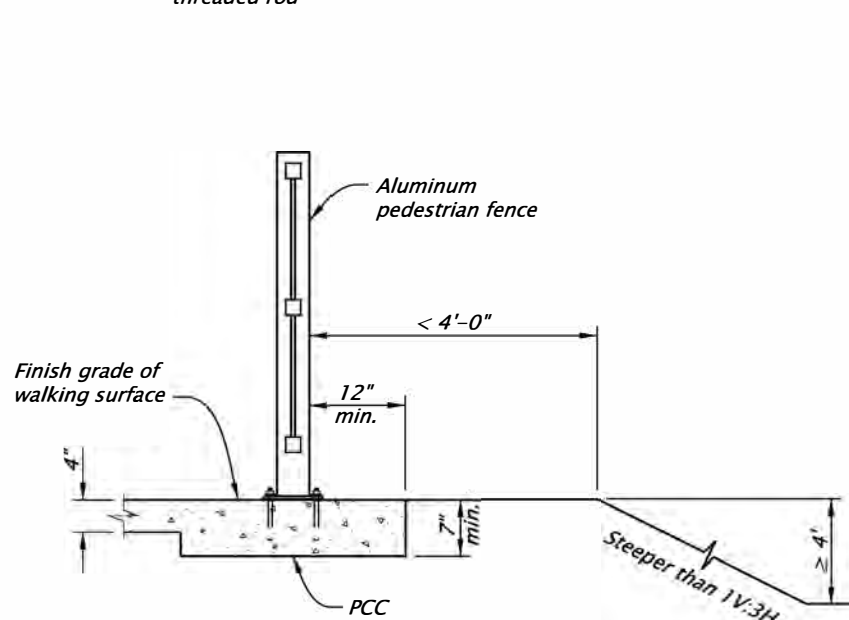
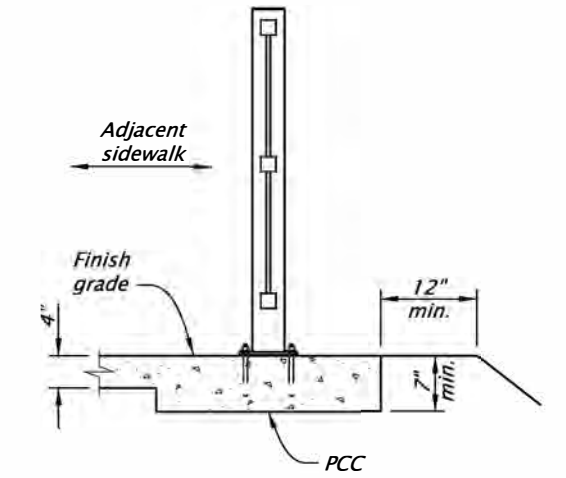
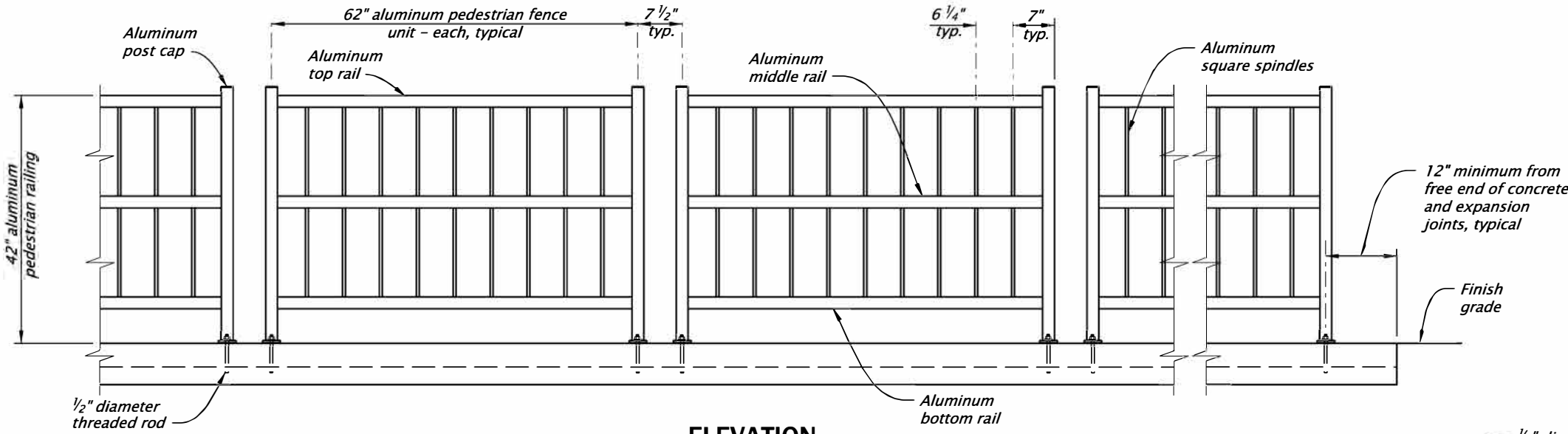
19-JAN-2024

RD780.dgn

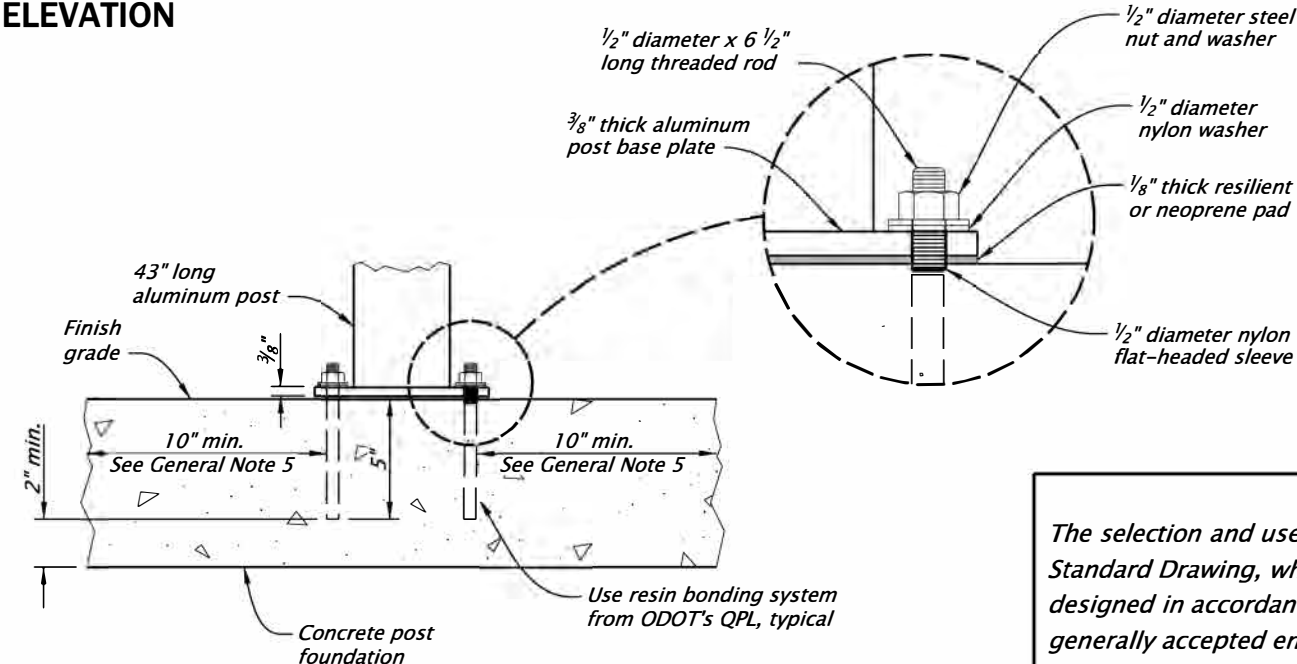


GENERAL NOTES FOR ALL DETAILS ON THIS SHEET:

1. See Std. Dwgs. RD781 and RD782 for details not shown.
2. Structure varies, see project plans.
3. All concrete shall be commercial grade concrete.
4. See project plans for details not shown.
5. 10 inch minimum required between threaded rod and outer edge of concrete footing.



WHEN PEDESTRIAN FENCE IS REQUIRED FOR WALKING SURFACES



The selection and use of this Standard Drawing, while designed in accordance with generally accepted engineering principles and practices, is the sole responsibility of the user and should not be used without first consulting a Registered Professional Engineer.

All materials shall be in accordance with the current City of The Dalles Standard Specifications.

CITY OF THE DALLES STANDARD DRAWINGS

ALUMINUM PEDESTRIAN FENCE (MASH, TL-2)

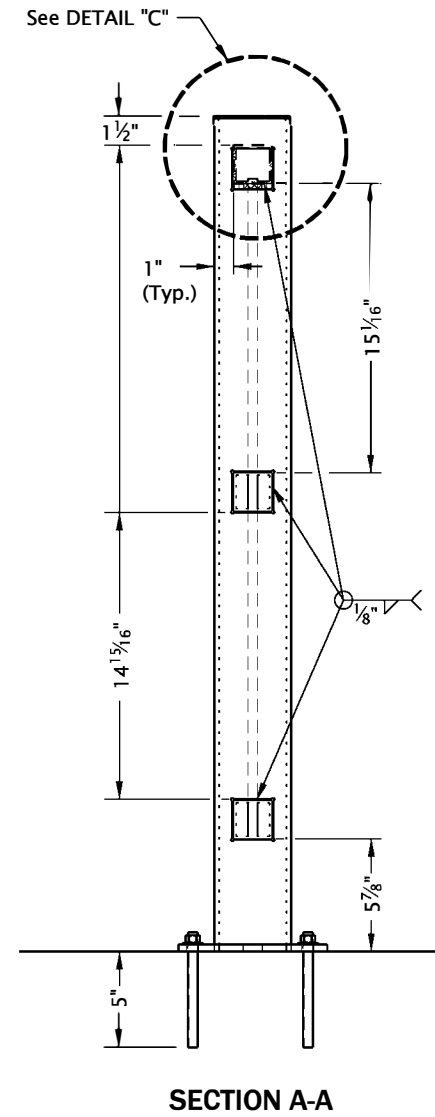
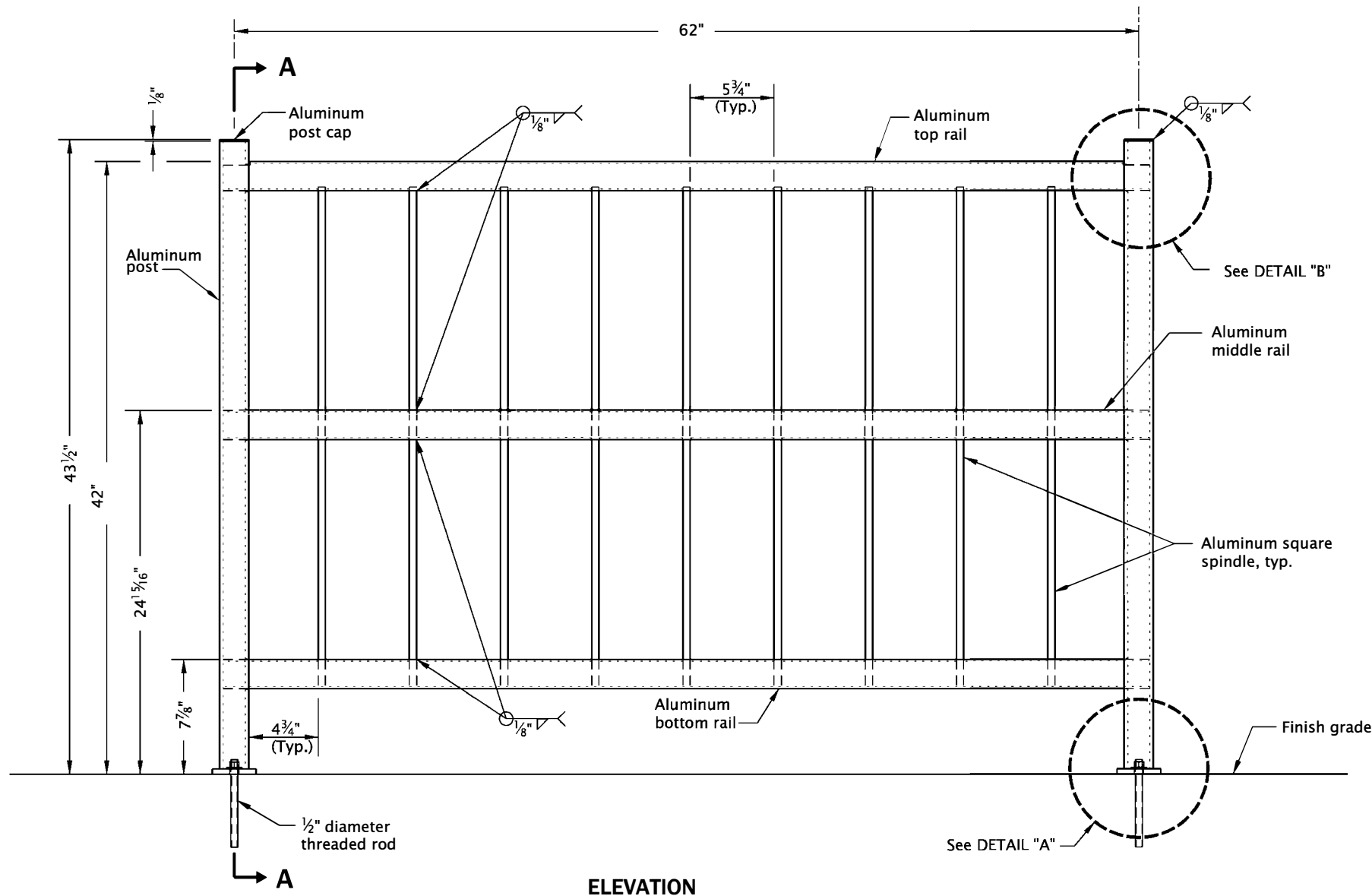
2025

DATE	REVISION DESCRIPTION
07-2020	NEW DRAWING CREATED
07-2021	REVISED DETAILS AND NOTES
01-2023	REVISED NOTE
12-2023	REVISED DETAILS AND NOTES, UPDATED CAD DRAWING STANDARDS

CALC. BOOK NO.	N/A	SDR DATE	19-JAN-2024	RD780
----------------	-----	----------	-------------	-------

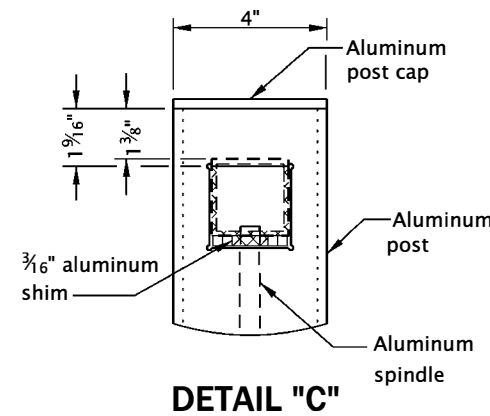
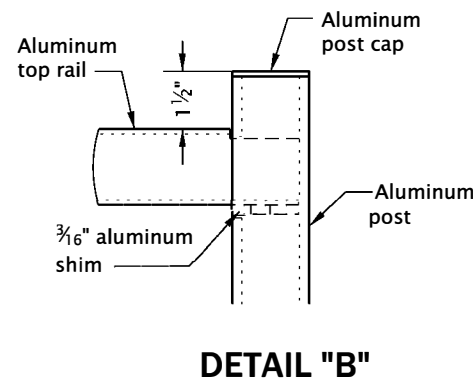
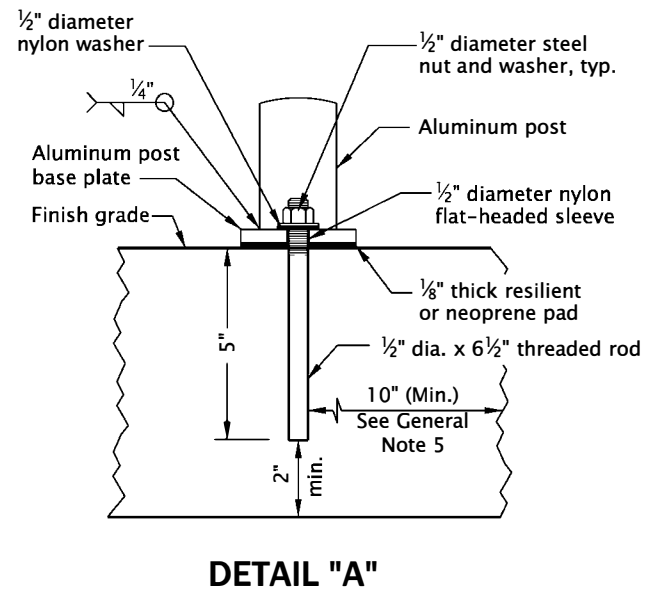
Effective Date: January 1, 2025 - December 31, 2025

RD781.dgn 19-JAN-2024



- GENERAL NOTES FOR ALL DETAILS ON THIS SHEET:
1. See Std. Dwgs. RD780 & RD782 for details not shown.
 2. Structure varies, see project plans.
 3. All concrete shall be commercial grade concrete.
 4. See project plans for details not shown.
 5. 10 inch minimum required between threaded rod and outer edge of concrete footing.

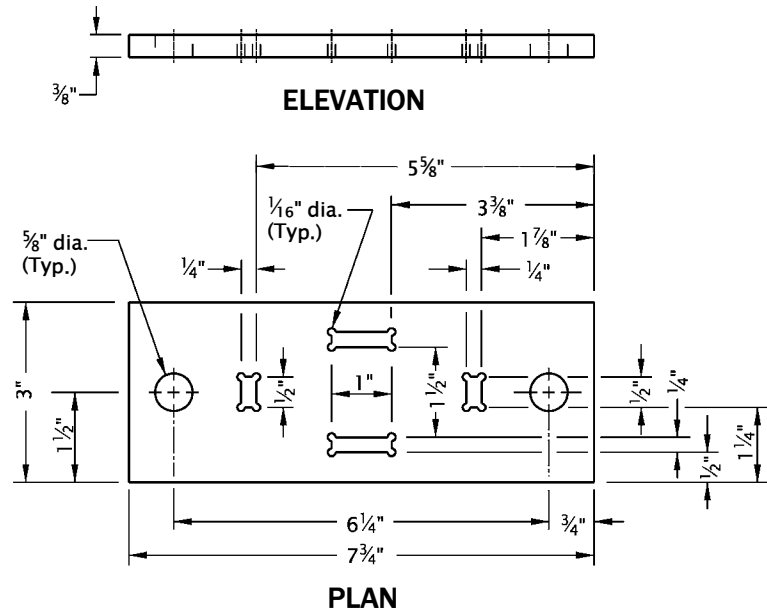
ALUMINUM PEDESTRIAN FENCE UNIT DETAILS



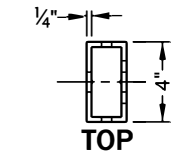
The selection and use of this Standard Drawing, while designed in accordance with generally accepted engineering principles and practices, is the sole responsibility of the user and should not be used without first consulting a Registered Professional Engineer.

All materials shall be in accordance with the current City of The Dalles Standard Specifications.	
CITY OF THE DALLES STANDARD DRAWINGS	
ALUMINUM PEDESTRIAN FENCE UNIT DETAILS	
2025	
DATE	REVISION DESCRIPTION
07-2020	NEW DRAWING CREATED
07-2021	REVISED DETAILS AND NOTES
01-2024	REVISED DETAIL A NOTE
CALC. BOOK NO.	SDR DATE
N/A	19-JAN-2024
RD781	

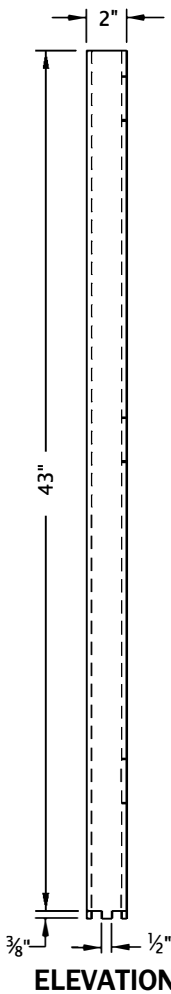
Effective Date: January 1, 2025 – December 31, 2025



ALUMINUM POST BASE PLATE

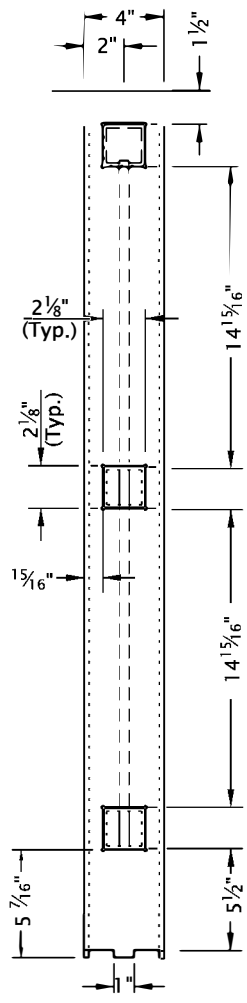


TOP



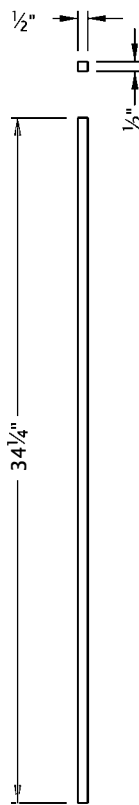
ELEVATION

ALUMINUM POST
(2"X4"X1/4" - 43" LONG)



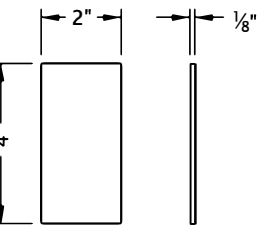
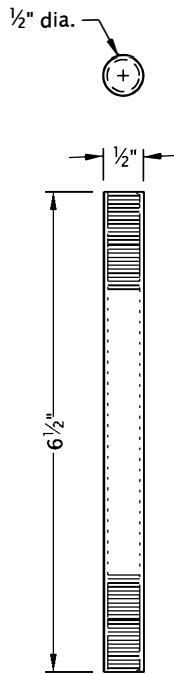
SIDE

ALUMINUM SPINDLE
(1/2"X1/2" SQUARE - 32 1/8" LONG)

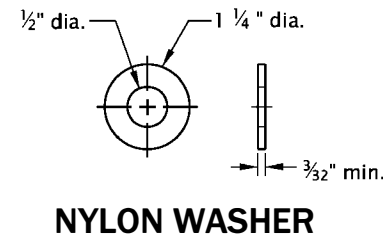


ALUMINUM SPINDLE

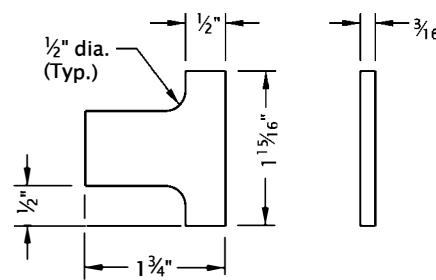
THREADED ROD
(1/2" DIAMETER UNC - 6 1/2" LONG)



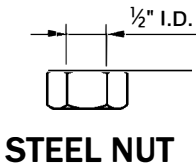
ALUMINUM POST CAP



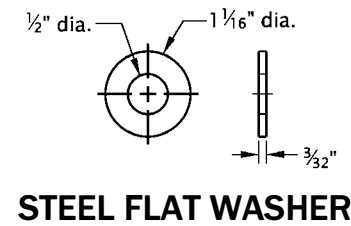
NYLON WASHER



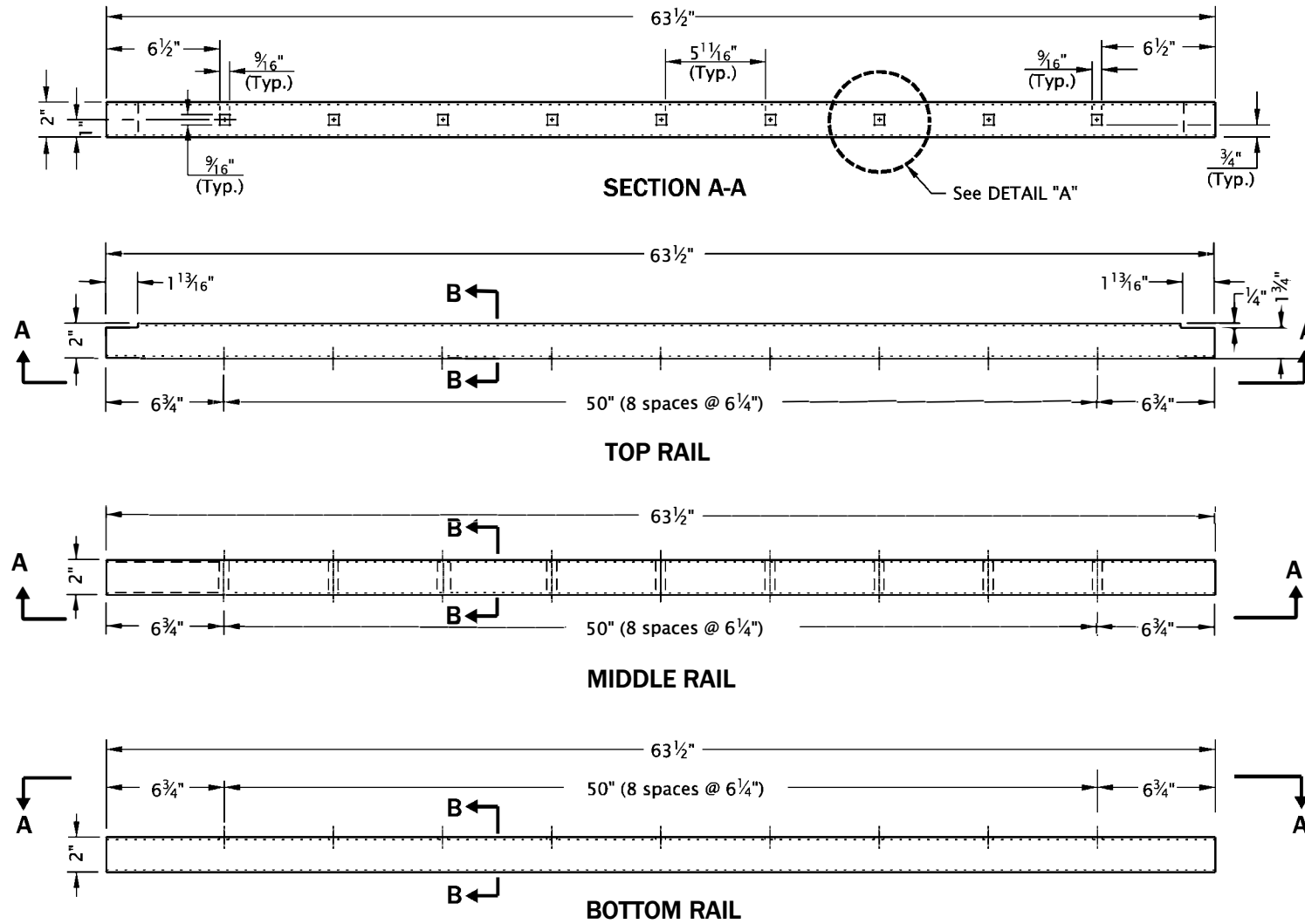
ALUMINUM SHIM



STEEL NUT



STEEL FLAT WASHER



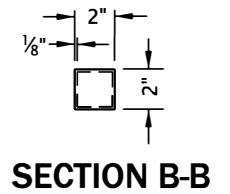
SECTION A-A

TOP RAIL

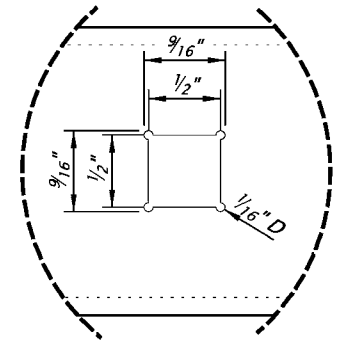
MIDDLE RAIL

BOTTOM RAIL

ALUMINUM RAIL ELEVATION



SECTION B-B



DETAIL "A"

GENERAL NOTES FOR ALL DETAILS ON THIS SHEET:

1. See Std. Dwg. RD780 for details not shown.
2. All aluminum welds should follow the aluminum design standard manual 2010 by using 5356 filler material.
3. All concrete shall be commercial grade concrete.
4. Structure varies, see project plans for details not shown.

The selection and use of this Standard Drawing, while designed in accordance with generally accepted engineering principles and practices, is the sole responsibility of the user and should not be used without first consulting a Registered Professional Engineer.

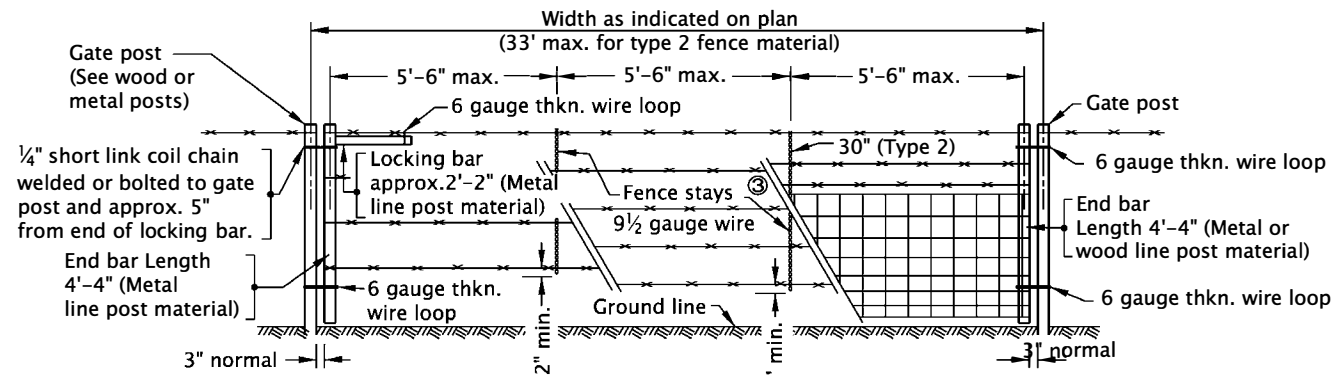
All materials shall be in accordance with the current City of The Dalles Standard Specifications.

CITY OF THE DALLES STANDARD DRAWINGS
ALUMINUM PEDESTRIAN FENCE
COMPONENT DETAILS
2025

DATE	REVISION DESCRIPTION
07-2020	NEW DRAWING CREATED
07-2021	REVISED DETAILS AND NOTES
01-2024	REVISED DETAILS AND NOTES

CALC. BOOK NO. - - - - -	N/A - - - - -	SDR DATE - 19-JAN-2024 -	RD782
--------------------------	---------------	--------------------------	--------------

rd810.dgn 20-JUL-2020



- NOTES:
 ① Match adjoining fence type.
 ② For details not shown see fence type.
 ③ For wooden stays, see Type 1 fence details.

TYPE 1 Fence material ①②
TYPE 1-5W Fence material ①②
TYPE 2 Fence material ①②

GATEWAY

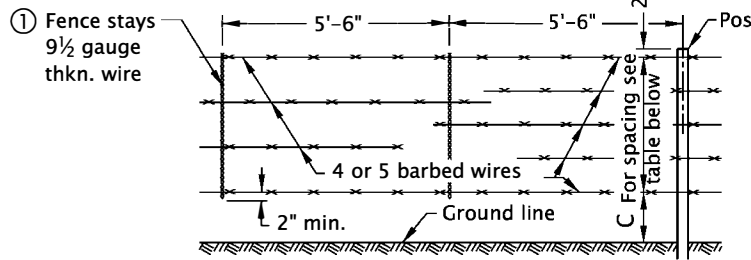
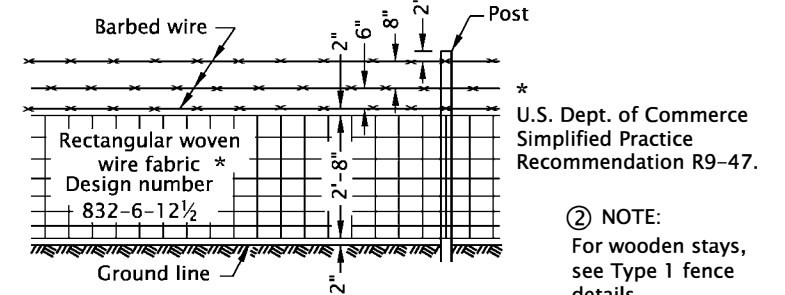


TABLE OF DIMENSIONS

FENCE	C	SPACING	NO. OF WIRES
Type 1	14"	12"	4
Type 1-5W	10"	10"	5

- ① NOTE:
 Wooden Stays to be used in areas of heavy snowfall or snow drifts over 36". Stays to be 2"x2"x52" min. length, sound, untreated Douglas Fir, Western Hemlock or Western Pine, spaced as shown for wire stays and to rest firmly on the ground.
 Horizontal wires to be stapled are: single wires and a minimum of 4 wires for woven wire fabric.

TYPES 1, & 1-5W

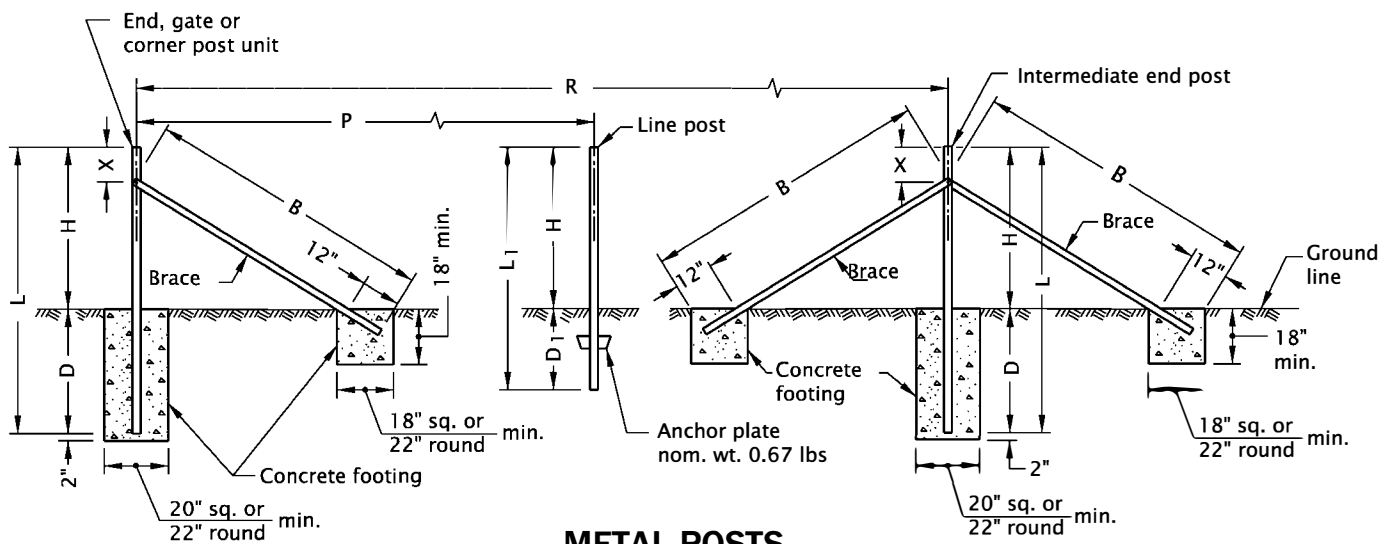


② TYPE 2

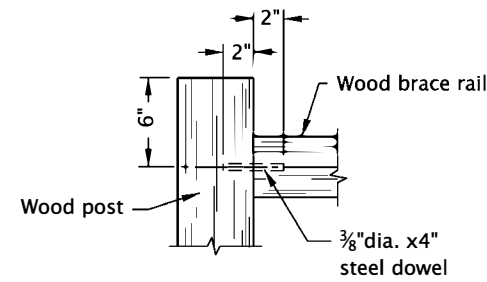
TABLE 1 (For wood posts)

FENCE	R (ft)	UNITS REQUIRED
Types { 1, 1-5W & 2	20 or Less	* None
	20-330	A
	Over 330	A & B

* Unit A required at gate post.
 Either Unit A or Units A & B are required in existing fence line at intersection with new fence line.



METAL POSTS



BRACE RAIL CONNECTION

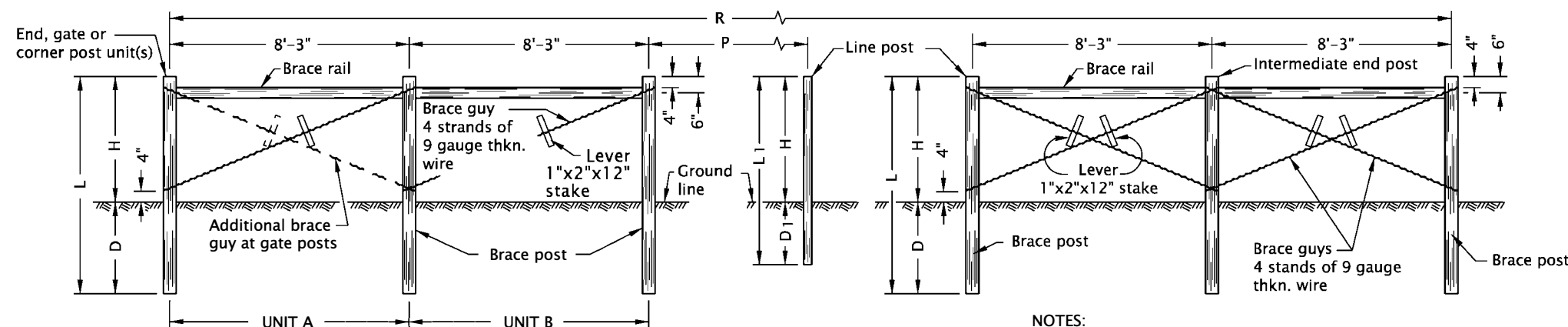
TABLE 2

FENCE	R max.	P	L min.	L1 min.	H	D min.	D1 min.	B min.	X min.-max.
All Types	660'	16'-6"	7'-6"	6'-6"	4'-4"	3'-2"	2'-2"	7'-8"	9"-22"

TABLE 3

MEMBER	WOOD		SHAPE	WEIGHT PER (ft) nominal	SIZE nominal
	* ROUND	SQUARE			
	DIAMETER OF SMALL END (in) min.-max.	SIZE nominal (in) min. avg.			
Line Post	3" to 4"	3"	† 3"x3"	Tee Channel (a) or U-bar	1.33 lb ASTM A-702
Brace or Brace Rail	3 1/2" to 5 1/2"	4"	4"x4"	Tubular	(b)
				(a) Angle	3.19 lb 2"x2"x1/4"
Other Post	4" to 7"	5"	† 5"x5"	Tubular	b 2 3/8" O.D.
				(a) Angle	4.1 lb 2 1/2"x2 1/2"x1/4"

* Max. taper 1":48".
 † Max. allowable size 1" additional in each dimension.
 (a) In accordance with ASTM A 702.
 (b) In accordance with AASHTO M 181.



WOOD POSTS

- NOTES:
 1. For dimensions indicated by letter see Table 2.
 2. Line post spacing same as dimension P.
 3. For cross sectional dimensions of members see Table 3.

- GENERAL NOTES FOR ALL DETAILS ON THIS SHEET:
 1. For dimensions indicated by letter see Table 2.
 2. Line post spacing same as dimension P.
 3. For shapes, weights and dimensions of members see Table 3.

4. All concrete shall be commercial grade concrete.
 5. See Std. Dwg. RD820 for fence gates.
 6. See project plans for details not shown.
 7. Add fence grounding as required.

The selection and use of this Standard Drawing, while designed in accordance with generally accepted engineering principles and practices, is the sole responsibility of the user and should not be used without consulting a Registered Professional Engineer.

CALC. BOOK NO. N/A SDR DATE 13-JAN-2020

NOTE: All material and workmanship shall be in accordance with the current City of The Dalles Standard Specifications.

CITY OF THE DALLES STANDARD DRAWINGS

BARBED AND WOVEN WIRE FENCES
 2025

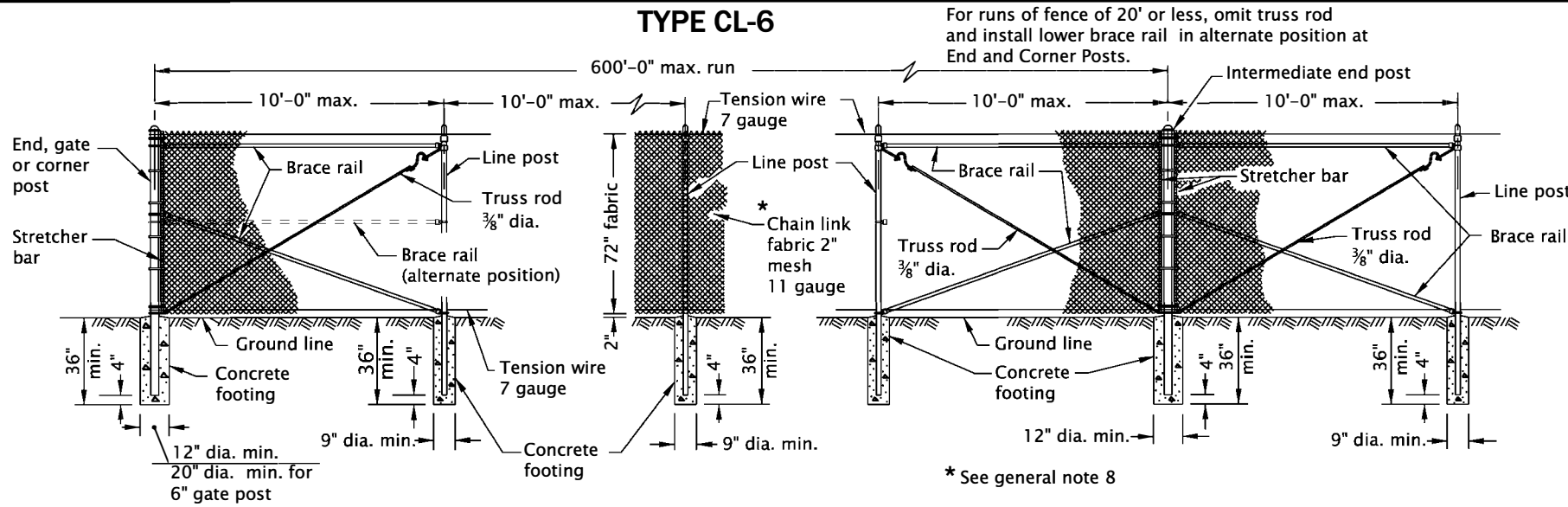
DATE	REVISION	DESCRIPTION

RD810

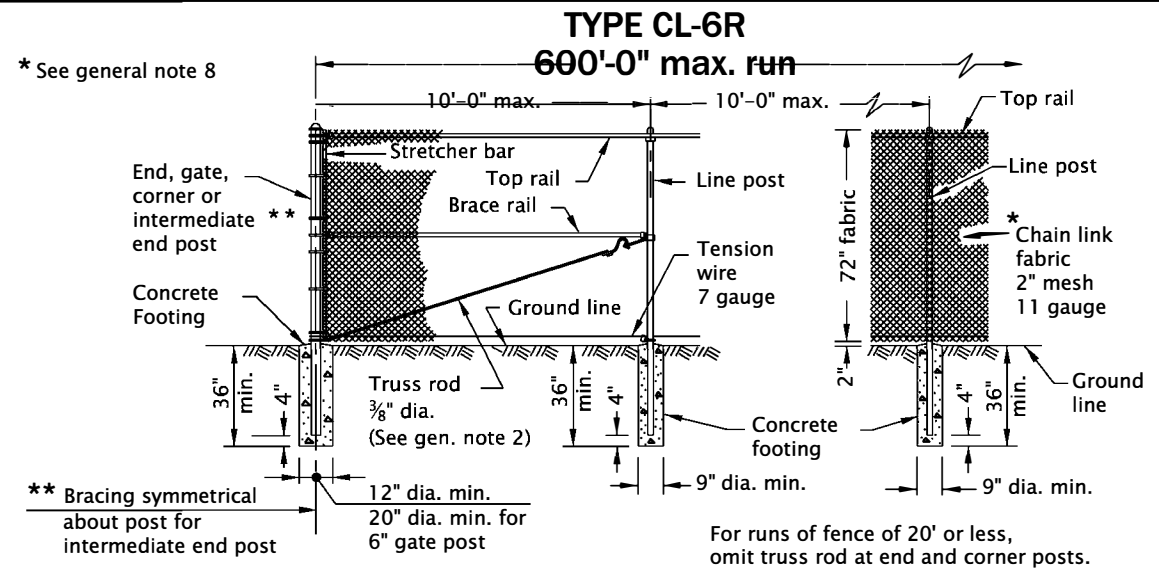
rd15.dgn 20-JUL-2020

RD815

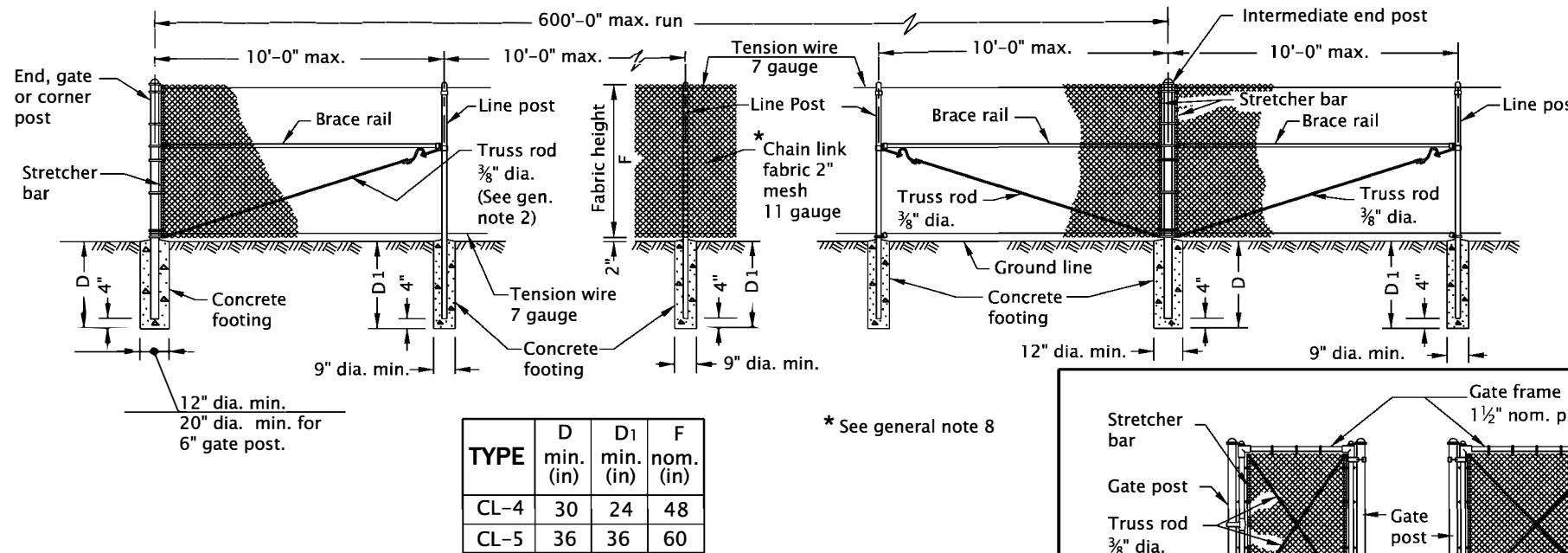
TYPE CL-6



TYPE CL-6R

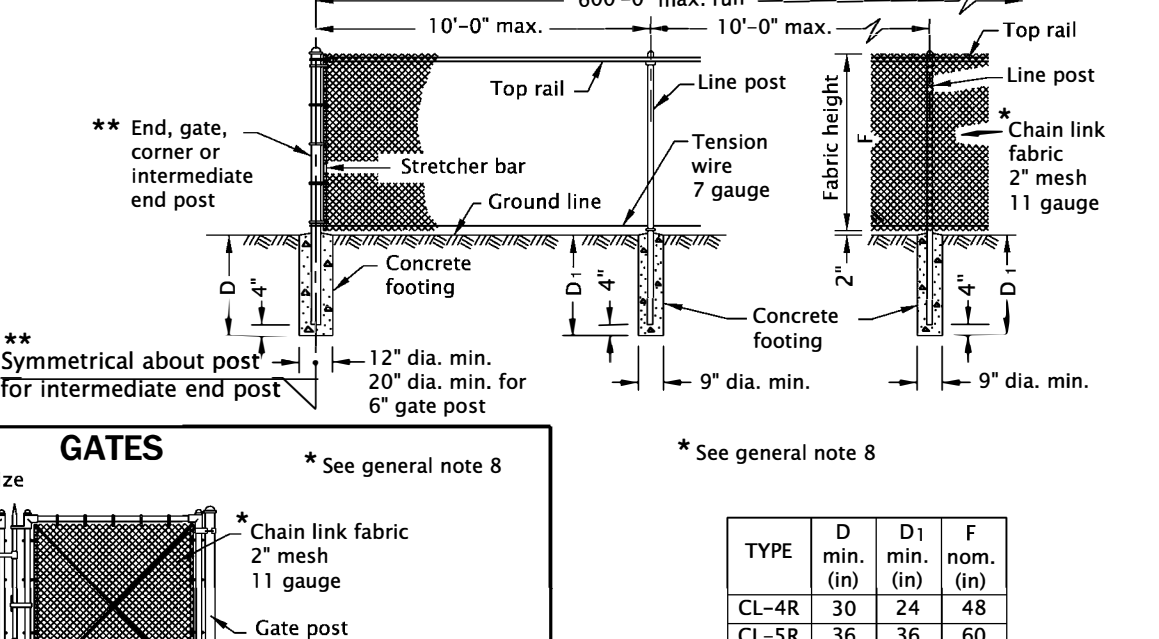


TYPES CL-4 & CL-5



TYPE	D min. (in)	D1 min. (in)	F nom. (in)
CL-4	30	24	48
CL-5	36	36	60

TYPES CL-4R & CL-5R



TYPE	D min. (in)	D1 min. (in)	F nom. (in)
CL-4R	30	24	48
CL-5R	36	36	60

GATES

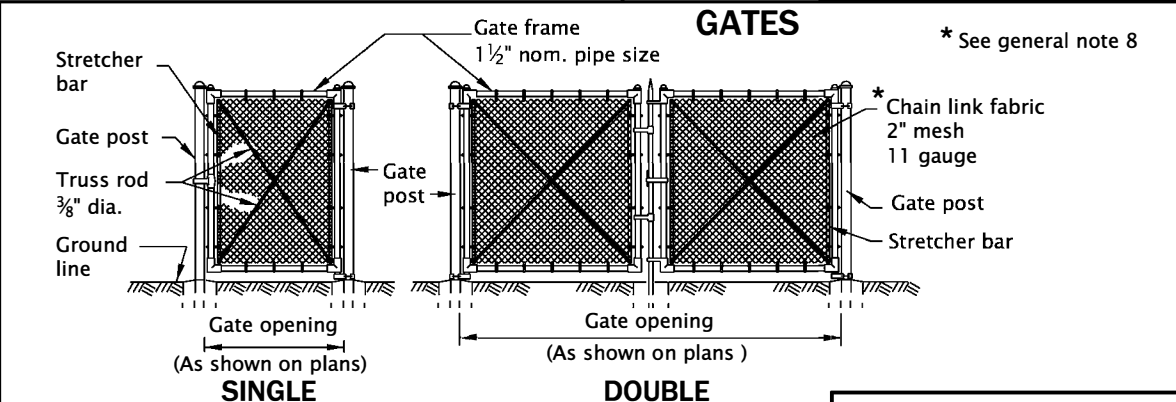


TABLE 1

TYPE	MEMBER											
	BRACE AND TOP RAILS		LINE POSTS				END, CORNER & INTERMEDIATE END POST		GATE OPENING (ft)		GATE POSTS	
	TUBULAR	TUBULAR	H-SECTION		TUBULAR		SINGLE GATE	DOUBLE GATE	TUBULAR			
CL-4 & CL-4R CL-5 & CL-5R	Fence Industry (in) 1 5/8	Norm. Dia. (in) 1 1/4	Fence Industry (in) 1 7/8	Norm. Dia. (in) 1 1/2	Size (in) 1 7/8 x 1 5/8	Wt. lb/ft 2.72	Fence Industry (in) 2 3/8	Norm. Dia. (in) 2	Up thru 6	Up thru 12	Fence Industry (in) 2 7/8	Norm. Dia. (in) 2 1/2
CL-6 & CL-6R	1 5/8	1 1/4	2 3/8	2	2 1/4 x 2	4.10	2 7/8	2 1/2	7 thru 13	13 thru 26	4	3 1/2
									14 thru 18	27 thru 36	6 3/8	6

NOTE: For CL-6, CL-6R, CL-8, CL-8R, CL-10 & CL-10R, the hardware is minimum and does not include slat wind loading.

- GENERAL NOTES FOR ALL DETAILS ON THIS SHEET:
- Do not use top rail where fence can be struck by an errant vehicle.
 - Fittings shown are illustrative of use and not specific as to design.
 - Gate posts on each side of a gate opening to be the same size. At a double gate installation with unequal width gates, size of both posts to be as indicated for a single gate installation of the wider gate width.
 - For cross sectional dimensions of members, see Table 1.
 - Posts and rails with sections not shown that meet the requirements of AASHTO M181 are acceptable alternates. See ODOT's QPL for acceptable alternates.
 - All concrete shall be commercial grade concrete.
 - All chain link fabric top and bottom selvage shall be knuckled finish.
 - Chain link fabric for the fence to be installed with pickets shall be 9 gauge wire woven in 3 1/2" by 5 1/2" diamond mesh.
 - See project plans for details not shown.
 - Add fence grounding as required.

The selection and use of this Standard Drawing, while designed in accordance with generally accepted engineering principles and practices, is the sole responsibility of the user and should not be used without consulting a Registered Professional Engineer.

CALC. BOOK NO. N/A

SDR DATE 13-JAN-2020

NOTE: All material and workmanship shall be in accordance with the current City of The Dalles Standard Specifications

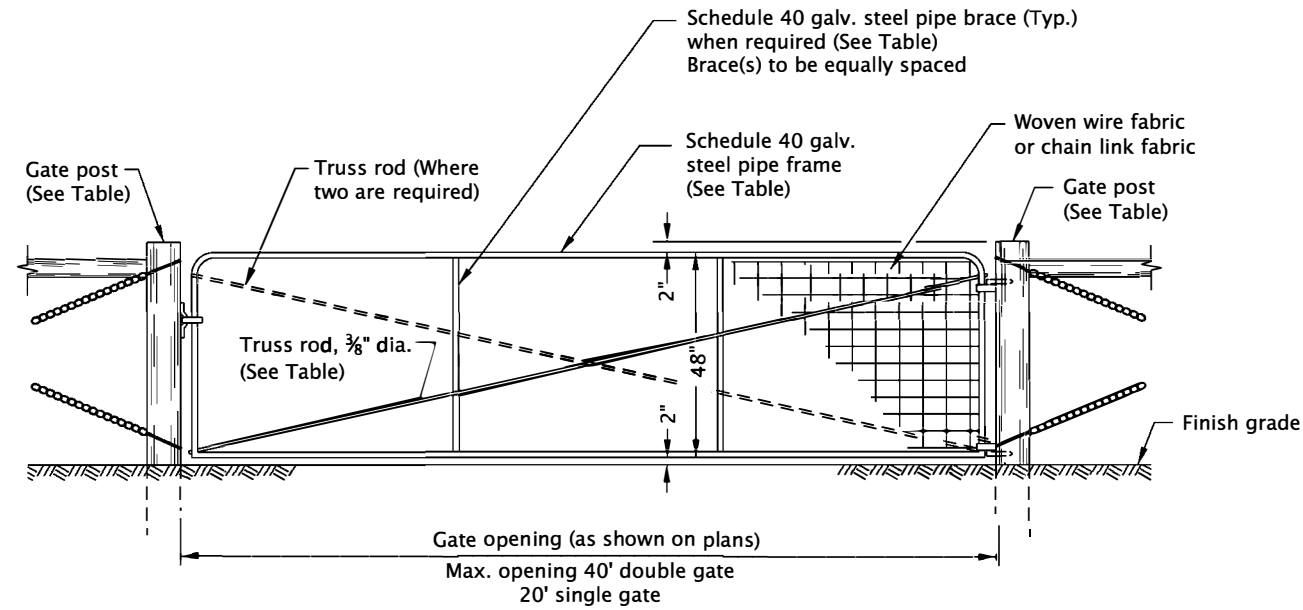
CITY OF THE DALLES STANDARD DRAWINGS

CHAIN LINK FENCE

2025

DATE	REVISION	DESCRIPTION

rd820.dgn 20-JUL-2020



GATE COMPONENTS							GATE POSTS ① ②						
GATE OPENING (ft)		SCHEDULE 40 GALV. STEEL PIPE FRAME		SCHEDULE 40 GALV. STEEL PIPE BRACE			TRUSS RODS	WOOD			STEEL		
SINGLE GATE	DOUBLE GATE	NOM. DIA. (in)	MIN. WT. (lb/ft)	NUMBER	NOM. DIA. (in)	MIN. WT. (lb/ft)		* ROUND			SQUARE	SCHEDULE 40 GALV. STEEL PIPE	
								DIA. OF SMALL END (in)				NOM. SIZE (in)	NOM. DIA. (in)
							Min.	Max.	Min. Avg.				
UP thru 6	UP thru 12	1	1.68	-	-	-	-	5	7	6	6x6	2½	5.79
7 thru 11	13 thru 22	1¼	2.27	1	1	1.68	1	5	7	6	6x6	3½	9.11
12 thru 16	23 thru 32	1½	2.72	2	1¼	2.27	2	7	9	8	8x8	6	18.97
17 thru 20	33 thru 40	2	3.65	2	1¼	2.27	2	9	11	10	10x10	6	18.97

① Gate posts on each side of a gate opening to be the same size. At a double gate installation with unequal width gates, size of both posts to be as indicated for single gate installation of the wider gate width.

② For length, setting and bracing details see end posts, Std. Dwg. RD810.

* Max. taper 1" in 4'

GENERAL NOTES FOR ALL DETAILS ON THIS SHEET:

- Gates shown are for use with Fence Types 1, 1-5W and 2.
- See Std. Dwg. RD810 for details not shown.
- See project plans for details not shown.
- Add fence grounding as required.

CALC. BOOK NO. N/A

SDR DATE 13-JAN-2020

NOTE: All material and workmanship shall be in accordance with the current City of The Dalles Standard Specifications

CITY OF THE DALLES STANDARD DRAWINGS

FENCE GATES

2025

DATE	REVISION	DESCRIPTION


The selection and use of this Standard Drawing, while designed in accordance with generally accepted engineering principles and practices, is the sole responsibility of the user and should not be used without consulting a Registered Professional Engineer.


RD820


CURB RAMP INDEX


STD. DWG. NO.	STD. DWG. TITLE
RD900	Curb Ramp Components And Legend
RD901	Curb Ramp Legend And Corner Identification
RD902	Detectable Warning Surface Details
RD904	Detectable Warning Surface Placement For Curb Ramps
RD905	Detectable Warning Surface Placement For Directional Curbs
RD906	Detectable Warning Surface Placement For Accessible Route Island
RD908	Detectable Warning Surface Placement For Rail
RD909	Detectable Guide Strip Placement At Bike Ramps
RD910, RD912	Perpendicular Curb Ramp
RD913	Perpendicular Curb Ramp With Closure
RD916	Perpendicular Curb Ramp Single Ramp
RD920	Parallel Curb Ramp
RD922	Parallel Curb Ramp Single Ramp
RD930, RD932 & RD936	Combination Curb Ramp
RD938	Combination Curb Ramp Single Ramp
RD940	Blended Transition Curb Ramp Single Ramp
RD950 & RD952	End Of Walk Curb Ramp
RD960	Unique Curb Ramp


LEGEND:


 Marked or intended crossing location


 Sidewalk or other traversable surface


 Detectable warning surface (DWS)


 Level area (Turning space/landing)


 Cross slope 1.5% max.
(Max. 2.0% finished surface slope)
(Normal sidewalk cross slope)

 Running slope 4.0% max.
(Max. 4.9% finished surface slope)

 Running slope 7.5% max.
(Max. 8.3% finished surface slope)

 Counter slope 4.0% max. ascending or descending
(Max. 5.0% finished surface slope)
Slope as required for drainage

 Flare slope
(Max. 10.0% finished surface slope)

 4'x4' clear space

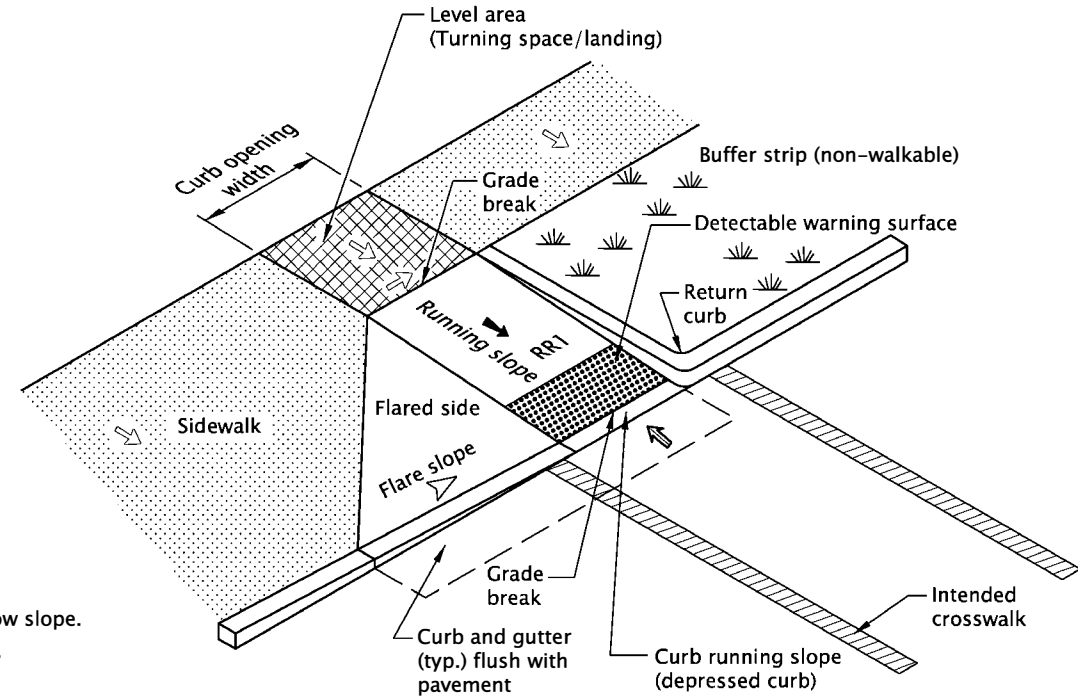
RR1 Ramp Run Position 1

INTERSECTION CONDITION TYPES

MB = Midblock, less than or equal to roadway grade finished gutter flow slope.

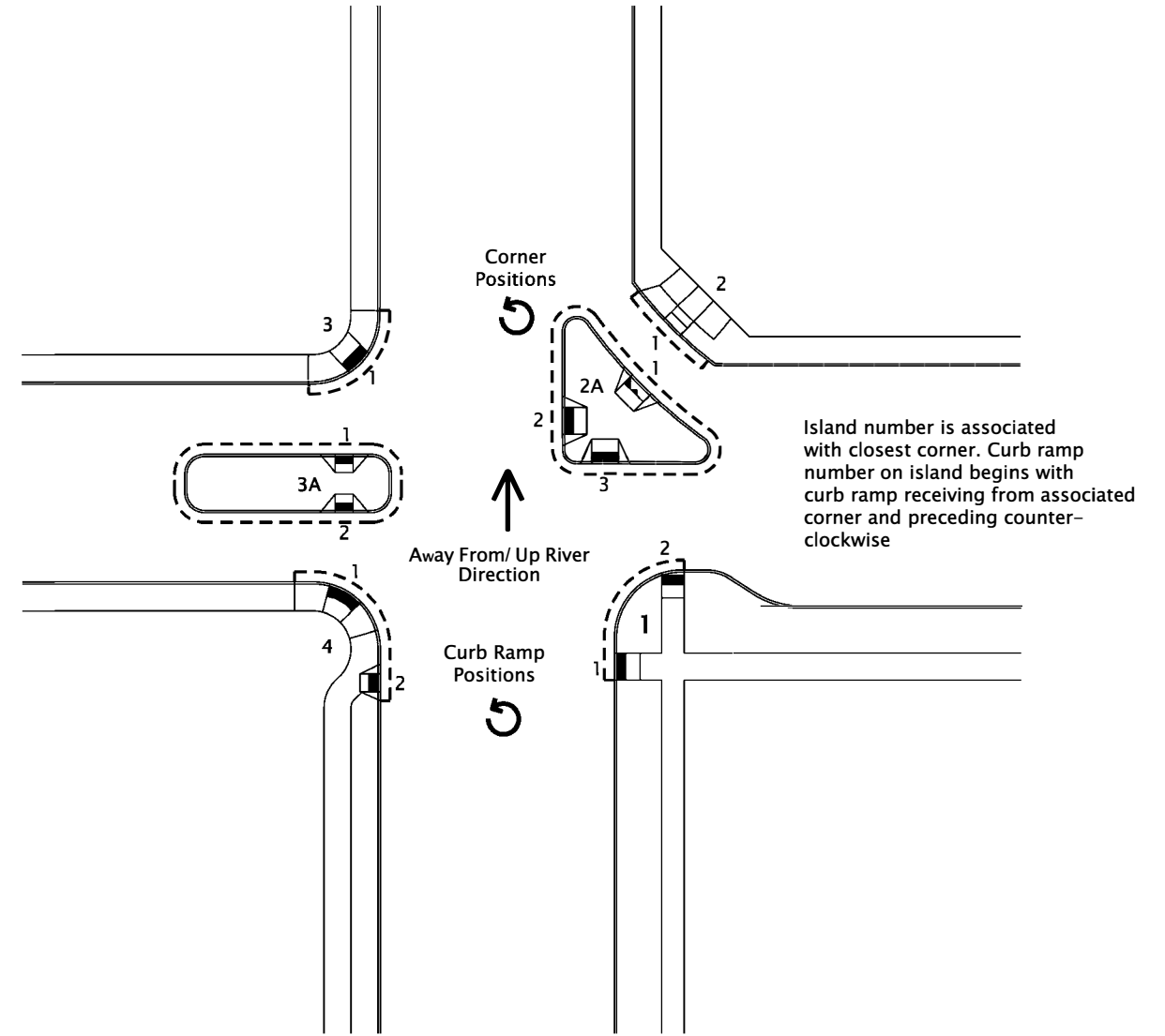
SU = Signalized or Uncontrolled, max. 5.0% finished gutter flow slope.

SY = Stop or Yield, max. 2.0% finished gutter flow slope.



TYPICAL CURB RAMP SYSTEM COMPONENTS
(PERPENDICULAR TYPE SHOWN)

<p><i>The selection and use of this Standard Drawing, while designed in accordance with generally accepted engineering principles and practices, is the sole responsibility of the user and should not be used without first consulting a Registered Professional Engineer.</i></p>		<p>All materials shall be in accordance with the current City of The Dalles Standard Specifications.</p>	
		<p>CITY OF THE DALLES STANDARD DRAWINGS</p> <p>CURB RAMP COMPONENTS AND LEGEND</p> <p>2025</p>	
DATE	REVISION DESCRIPTION		
07-2020	NEW DRAWING CREATED		
07-2021	REVISED DETAILS AND NOTES		
01-2022	REVISED LEGEND		
11-2023	REVISED LEGEND		
CALC. BOOK NO.	N/A	SDR DATE	19-JAN-2024
			RD900



Corner Position is based on traveling in the increasing mile point direction, beginning with the first corner on the right and proceeding counter-clockwise around the intersection, numbering consecutive 1 through the end of corners. An "A" is added to the number for an island. For example an island between corner positions 1 and 2 and is closer to corner 2 has a corner position number of 2A (See corner position and curb ramp position diagram).

Curb Ramp Position is a number given to each curb ramp beginning with Corner Position 1. The first curb ramp encountered in the increasing mile point direction is number ramp 1. Then proceeds counter-clockwise around the corner, numbering in consecutive order. Proceed following the pedestrian route and in Corner Position Number order (see corner position and curb ramp position diagram).

STANDARD ABBREVIATION FOR CURB RAMP DETAILS

- FG = Finish Grade (Elevation ft.) i.e. FG XXX.XX'
- TFC = Top Face of Curb (Elevation ft.)
- TBC = Top Back of Curb (Elevation ft.)
- BFC = Bottom Face of Curb (Elevation ft.)
- gtr. = Gutter (Elevation ft.)
- GS = Gutter Slope (%), i.e. X.X%
- E = Curb Exposure (Inch), i.e. X"
- CS = Counter Slope on gutter pan (%)
- RRN = Ramp Run Number, i.e. RRX
- cl.sp. = Clear Space
- TS = Turning Space
- XS = Cross Slope
- LA = Level Area
- DWS = Detectable Warning Surface
- PAR = Pedestrian Access Route

INTERSECTION CONDITION TYPES

- MB = Midblock
- SU = Signalized or Uncontrolled
- SY = Stop or Yield

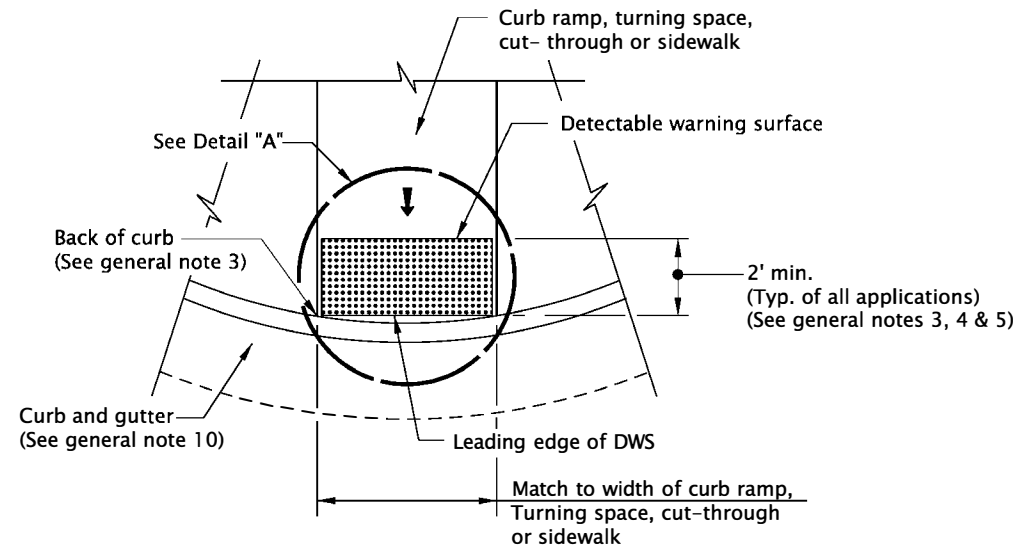
CORNER POSITION AND CURB RAMP POSITION DIAGRAM

(See ODOT Exhibit A for additional ramp and ramp run numbering conventions.)

CALC. BOOK NO. <u>N/A</u>		SDR DATE <u>07-SEPT-2021</u>	
NOTE: All material and workmanship shall be in accordance with the current City of The Dalles Standard Specifications			
CITY OF THE DALLES STANDARD DRAWINGS			
CURB RAMP LEGEND AND CORNER IDENTIFICATION			
2025			
DATE	REVISION DESCRIPTION		
07-2020	DRAWING CREATED		
09-2021	REVISED NOTES		

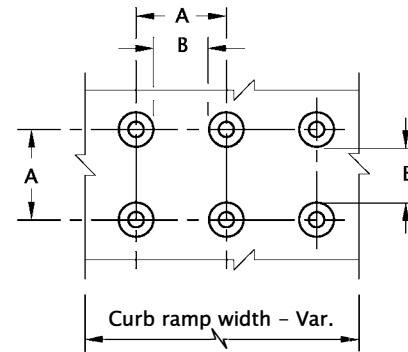
The selection and use of this Standard Drawing, while designed in accordance with generally accepted engineering principles and practices, is the sole responsibility of the user and should not be used without consulting a Registered Professional Engineer.

rd902.dgn 19-JUL-2021

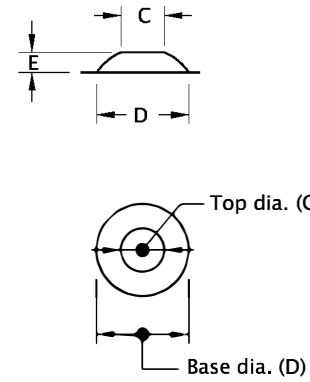


DETECTABLE WARNING SURFACE DETAIL

	A	B	C	D	E
MIN.	1.60"	0.65"	0.45"	0.90"	0.20"
MAX.	2.40"	--	0.91"	1.40"	0.20"

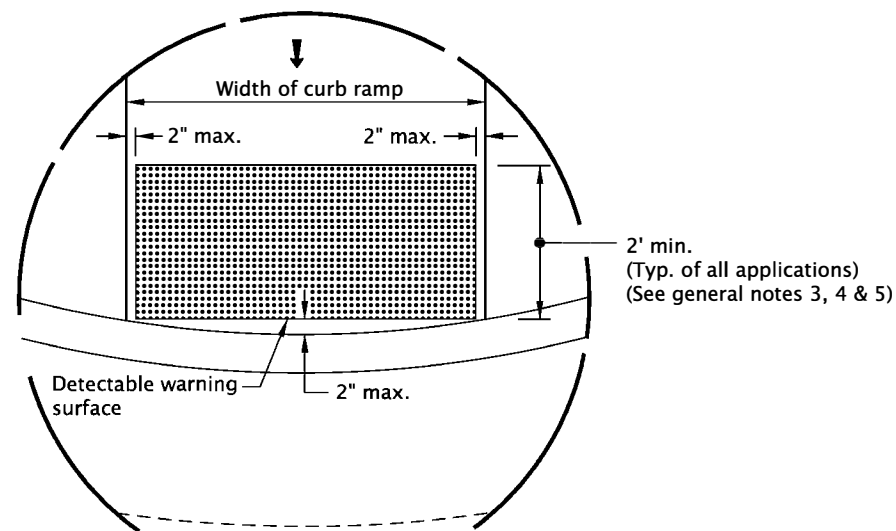


TRUNCATED DOME SPACING



TRUNCATED DOME

TRUNCATED DOME DETAILS



DETAIL "A"

GENERAL NOTES FOR ALL DETAILS ON THIS SHEET:

1. Detectable warning surface details & locations are based on applicable COTD Standards.
2. See project plans for details not shown. See Std. Dwgs. RD700 & RD701 for curbs.
3. The detectable warning surface shall extend the full width of the curb ramp opening, shared use path, blended transition, turning space, or other roadway entrance as applicable. A gap of up to 2 inches on each side of the detectable warning surface is permitted (measured at the leading edge of the detectable warning surface panel as shown in Detail "A").
4. Detectable warning surface shall be placed at the back of curb for a minimum depth of 2 ft. in the direction of pedestrian travel at curb ramps that are adjacent to traffic. Detectable warning surface may be radial or rectangular, but must comply with the truncated dome size and spacing standards. Detectable warning surface across a grade break is prohibited. Place abutting panels within 1/4 inch of each other and install anchors, as specified by manufacturers, along cut edge.
5. Color to be safety yellow if no color specified in construction note. Alternative colors require a design exception on or along state highways.
6. Detectable warning surface shall be used in the following locations:
 - a) Curb ramps at street crossings.
 - b) Crossing islands (Accessible Route Islands).
 - c) Rail crossings.
7. Where public transportation stations (rail, bus, etc.) use platform boarding, detectable warning surface shall be placed along the full edge length of the station, when not protected by platform screens or guards, (see Std. Dwg. RD908).
8. Detectable warning surface shall not be used on the following locations:
 - a) End of sidewalk transitions that are not at a crosswalk, (see Std. Dwgs. RD950, RD952 and RD960).
 - b) Driveways, unless constructed with curb return or are signalized.
 - c) Parking lots, access aisles and passenger loading zones where curb ramp does not lead to vehicular way.
9. Where no curb is present, the detectable warning surface shall be placed at the edge of the roadway.
10. Curb and gutter is required at curb ramps.

LEGEND:

- Detectable warning surface
- Cross slope 1.5% max.
(Max. 2.0% finished surface slope)
(Normal sidewalk cross slope)
- Running slope 7.5% max.
(Max. 8.3% finished surface slope)

CALC. BOOK NO. N/A	SDR DATE 19-JUL-2021
---------------------------	-----------------------------

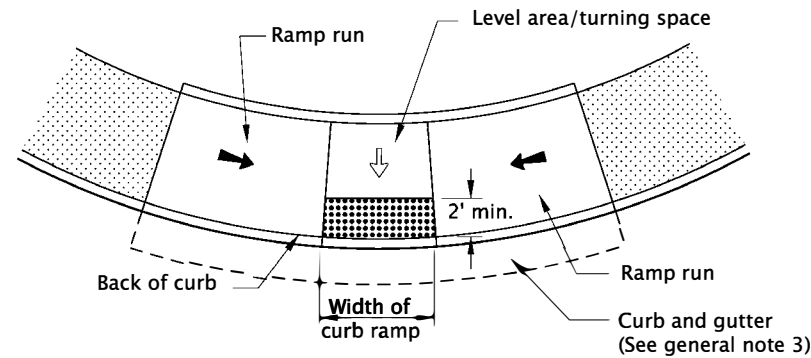
NOTE: All material and workmanship shall be in accordance with the current City of The Dalles Standard Specifications

The selection and use of this Standard Drawing, while designed in accordance with generally accepted engineering principles and practices, is the sole responsibility of the user and should not be used without consulting a Registered Professional Engineer.

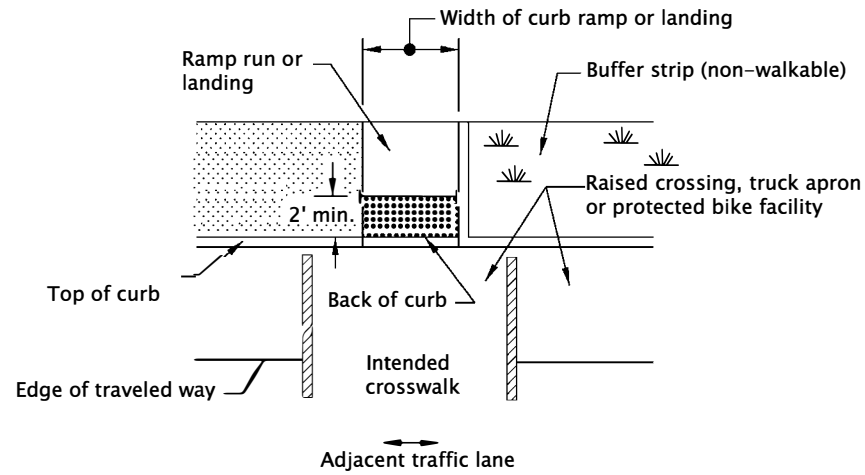
CITY OF THE DALLES STANDARD DRAWINGS
DETECTABLE WARNING SURFACE DETAILS

2025	
DATE	REVISION DESCRIPTION
07-2020	DRAWING CREATED
07-2021	REVISED DETAIL AND NOTES

rd 904.dgn 20-JUL-2020



PARALLEL CURB RAMP



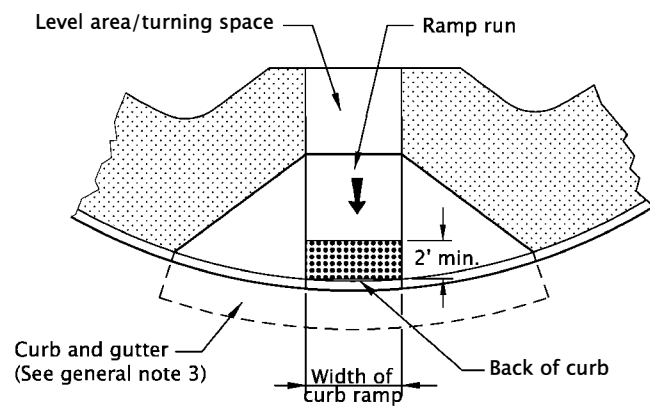
RAISED CROSSING, TRUCK APRON OR PROTECTED BIKE FACILITY

GENERAL NOTES FOR ALL DETAILS ON THIS SHEET:

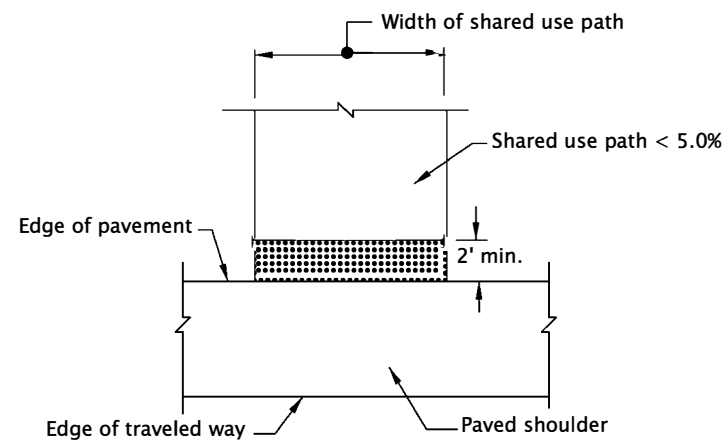
1. Detectable warning surface details & locations are based on applicable COTD Standards.
2. See project plans for details not shown.
See Std. Dwgs. RD700 & RD701 for curbs.
See Std. Dwg. RD902 for detectable warning surface installation details.
3. Curb and gutter is required at curb ramps.
4. Detectable warning surface placement for perpendicular ramps vary as shown.

LEGEND:

- Marked or intended crossing location
- Sidewalk
- Detectable warning surface
- Cross slope 1.5% max.
(Max. 2.0% finished surface slope)
(Normal sidewalk cross slope)
- Running slope 7.5% max.
(Max. 8.3% finished surface slope)



**PERPENDICULAR CURB RAMP
GRADE BREAK IN FRONT OF CURB**



SHARED-USE PATH CONNECTION

CALC. BOOK NO. N/A SDR DATE 20-JULY-2020

NOTE: All material and workmanship shall be in accordance with the current City of The Dalles Standard Specifications

The selection and use of this Standard Drawing, while designed in accordance with generally accepted engineering principles and practices, is the sole responsibility of the user and should not be used without consulting a Registered Professional Engineer.

**CITY OF THE DALLES STANDARD DRAWINGS
DETECTABLE WARNING SURFACE
PLACEMENT FOR CURB RAMPS**

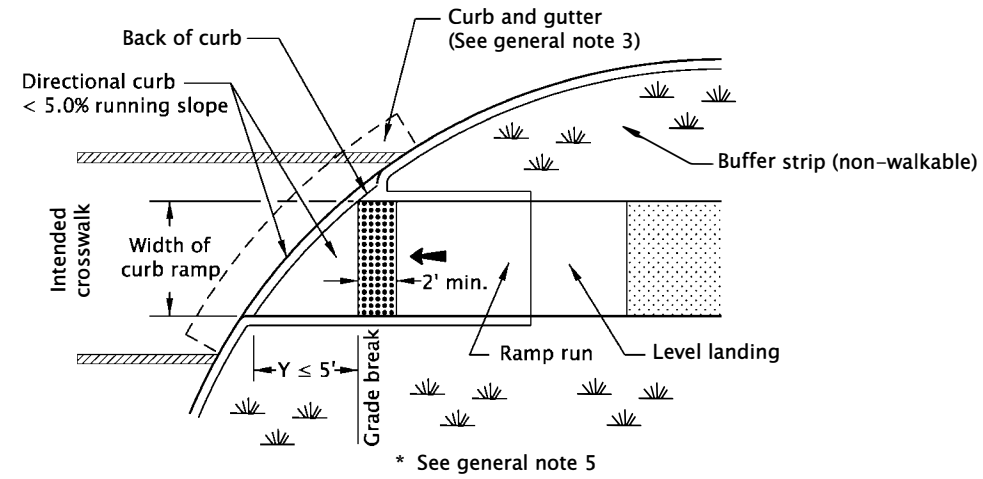
2025

DATE	REVISION DESCRIPTION
07-2020	DRAWING CREATED

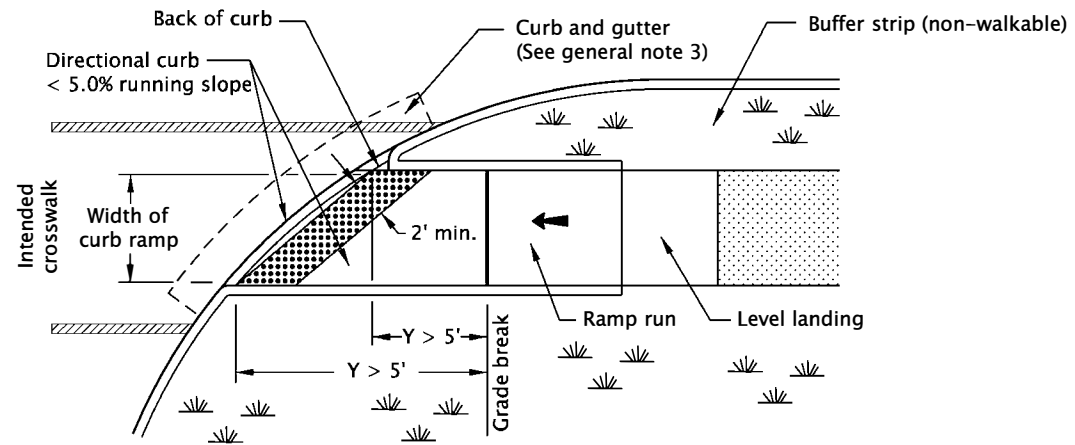
RD904

rd905.dgn 20-JUL-2020

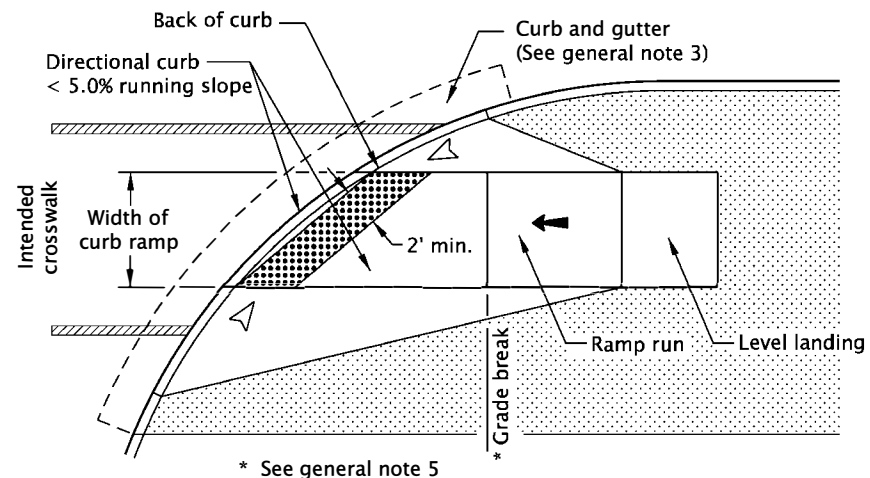
RD905



**CURB RAMP CROSSING
GRADE BREAK ≤ 5 FT. FROM BACK OF CURB**



**CURB RAMP CROSSING
GRADE BREAK > 5 FT. FROM BACK OF CURB**








**CURB RAMP CROSSING
DIRECTIONAL CURB WITH FLARED CONSTRUCTION**

GENERAL NOTES FOR ALL DETAILS ON THIS SHEET:

1. Detectable warning surface details & locations are based on applicable COTD Standards. See project plans for details not shown.
2. See Std. Dwgs. RD700 & RD701 for curbs.
See Std. Dwg. RD902 for detectable warning surface installation details.
3. Curb and gutter is required at curb ramps.
4. Detectable warning surface placement for perpendicular ramps vary as shown.
5. Detectable warning surface placement across the grade break is prohibited.

LEGEND:

-  Marked or intended crossing location
-  Sidewalk
-  Detectable warning surface
-  Running slope 7.5% max. (Max. 8.3% finished surface slope)
-  Flare slope (Max. 10.0% finished surface slope)

CALC. BOOK NO. N/A SDR DATE 20-JULY-2020

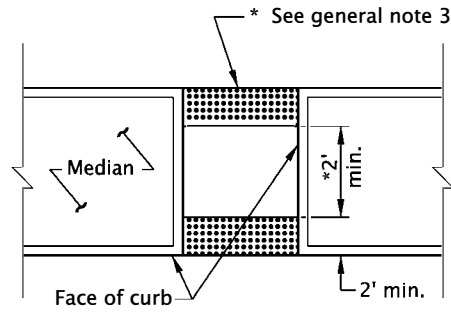
NOTE: All material and workmanship shall be in accordance with the current City of The Dalles Standard Specifications

The selection and use of this Standard Drawing, while designed in accordance with generally accepted engineering principles and practices, is the sole responsibility of the user and should not be used without consulting a Registered Professional Engineer.

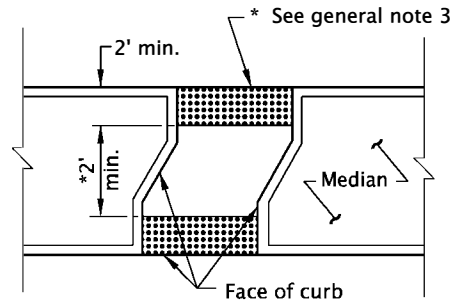
**CITY OF THE DALLES STANDARD DRAWINGS
DETECTABLE WARNING SURFACE
PLACEMENT FOR
DIRECTIONAL CURBS
2025**

DATE	REVISION	DESCRIPTION
07-2020	DRAWING CREATED	

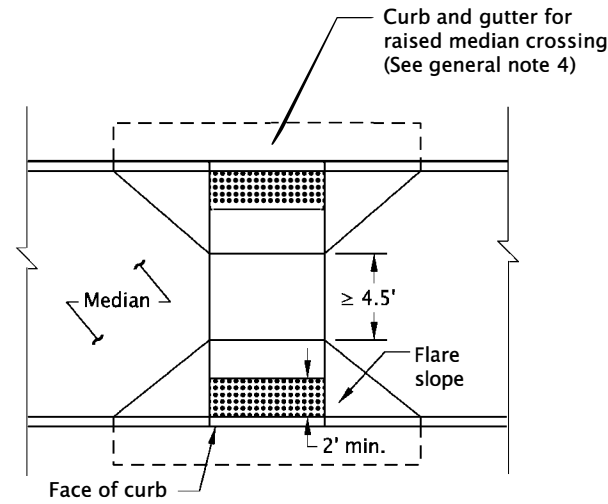
rd906.dgn 20-JUL-2020



* Omit detectable warning surfaces if less than 2'



CUT-THROUGH
(Asph. conc. surface shown)




RAISED MEDIAN
(P.C. conc. surface shown)

MEDIAN CROSSING

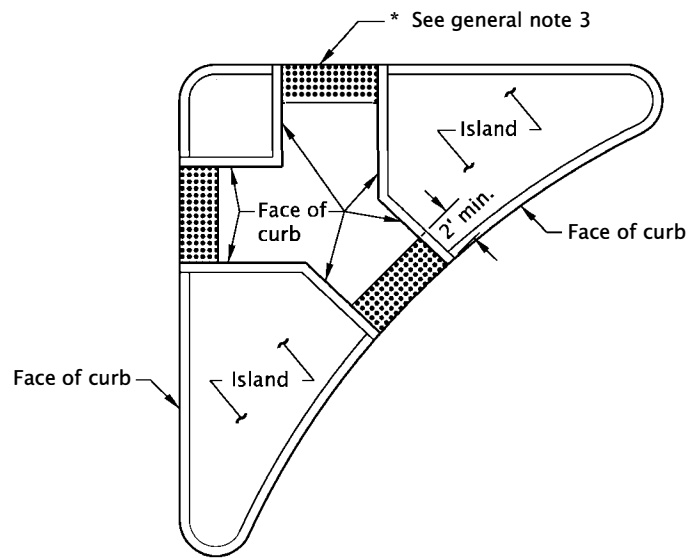
GENERAL NOTES FOR ALL DETAILS ON THIS SHEET:

1. Detectable warning surface details & locations are based on applicable COTD Standards.
2. See project plans for details not shown.
See Std. Dwgs. RD700 & RD701 for curbs.
See Std. Dwgs. RD710 & RD711 for accessible route island.
See Std. Dwg. RD902 for detectable warning surface installation details.
3. Detectable warning surfaces shall be separated by a 2.0 ft minimum length of walkway without detectable warnings. Where the island has no curb, the detectable warning surface shall be placed at the edge of roadway.
4. Curb and gutter is required at curb ramps.
5. Details intended for pedestrian route only. For protected bike lanes on multi-use paths, see project plans for specific details.

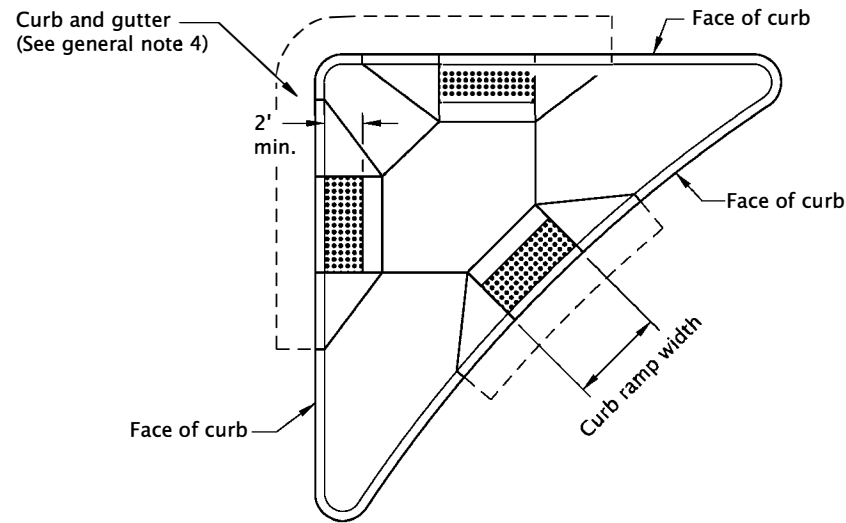
LEGEND:

 Detectable warning surface

* Omit detectable warning surfaces if less than 2'



CUT-THROUGH ISLAND
(Asph. conc. surface shown)



RAISED ISLAND
(P.C. conc. surface shown)

RIGHT TURN CHANNELIZATION ISLAND

CALC. BOOK NO. N/A SDR DATE 20-JULY-2020

NOTE: All material and workmanship shall be in accordance with the current City of the Dalles Standard Specifications

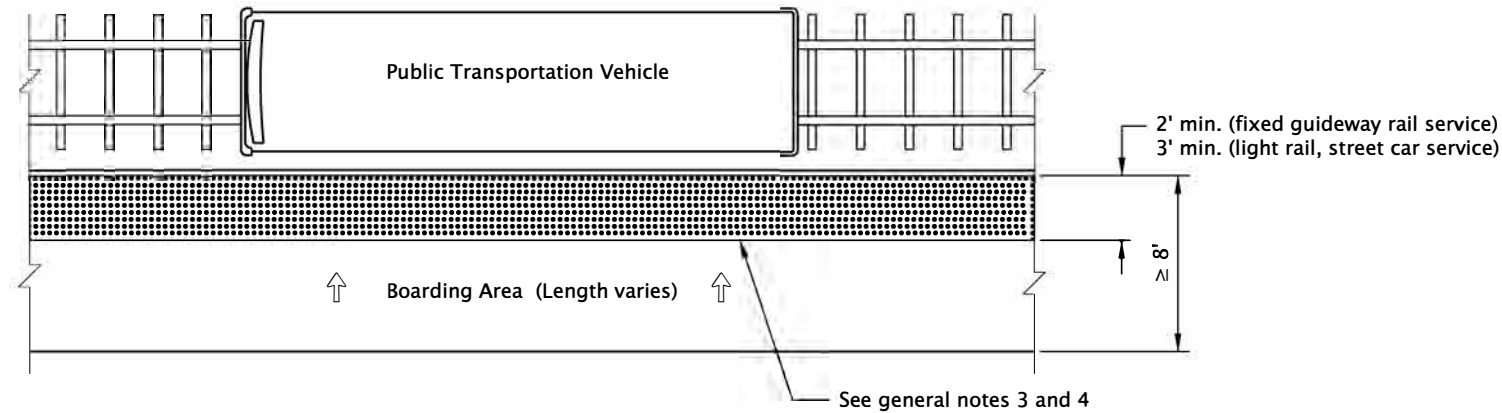
The selection and use of this Standard Drawing, while designed in accordance with generally accepted engineering principles and practices, is the sole responsibility of the user and should not be used without consulting a Registered Professional Engineer.

**CITY OF THE DALLES STANDARD DRAWINGS
DETECTABLE WARNING SURFACE
PLACEMENT
FOR ACCESSIBLE ROUTE ISLAND**

2025

DATE	REVISION	DESCRIPTION
07-2020	DRAWING CREATED	

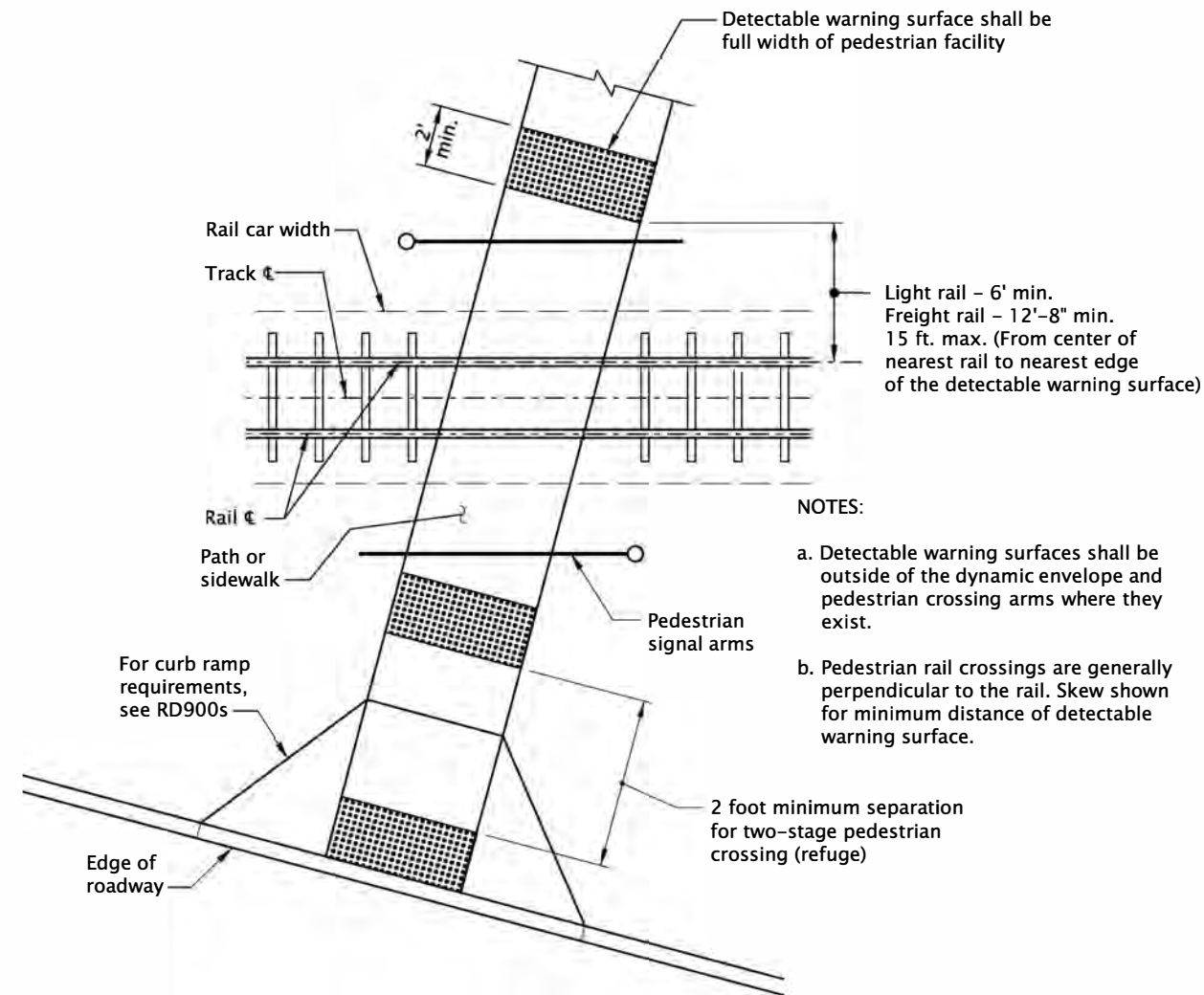
RD906



LEGEND:
 Detectable warning surface
 Cross slope 1.5% max.
 (Max. 2.0% finished surface slope)

PUBLIC TRANSPORTATION STATION
 Rail or Transit Service

See general notes 3 and 4

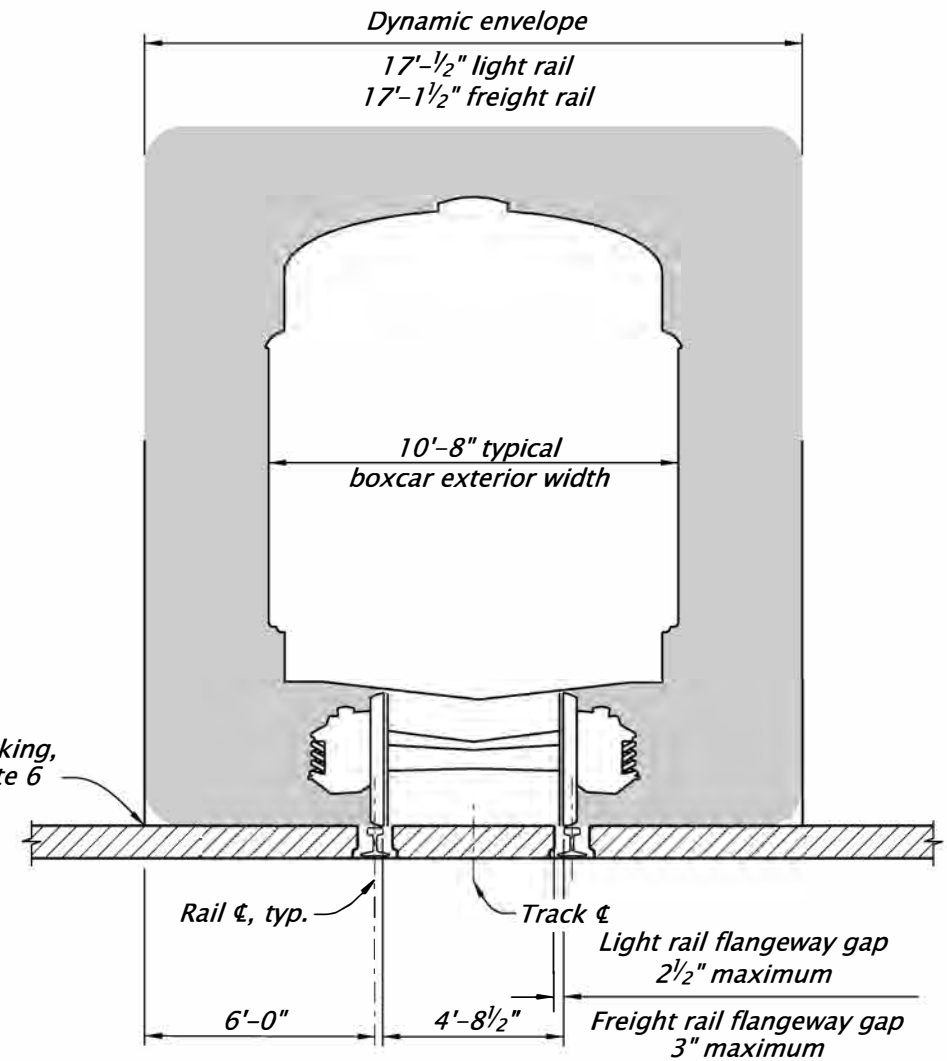


AT-GRADE RAIL CROSSING

- NOTES:**
- Detectable warning surfaces shall be outside of the dynamic envelope and pedestrian crossing arms where they exist.
 - Pedestrian rail crossings are generally perpendicular to the rail. Skew shown for minimum distance of detectable warning surface.

GENERAL NOTES FOR ALL DETAILS ON THIS SHEET:

- Detectable warning surface details and locations are based on applicable COTD Standards.
- See project plans for details not shown. See Std. Dwg. RD902 for detectable warning surface installation details.
- Place detectable warning surface along the full length of the rail station, when not protected by screens or guards on raised platforms, sidewalk, and street level boarding areas.
- Place detectable warning surface along the full length of the transit station, when not protected by screens or guards on raised platforms and sidewalk boarding areas.
- Detectable warning surfaces shall be outside of the dynamic envelope.
- Dynamic envelope shall be clear of all fixed obstructions unless otherwise shown on Rail Crossing Order.



RAIL TRACK SECTION VIEW

The selection and use of this Standard Drawing, while designed in accordance with generally accepted engineering principles and practices, is the sole responsibility of the user and should not be used without first consulting a Registered Professional Engineer.

All materials shall be in accordance with the current City of The Dalles Standard Specifications.

CITY OF THE DALLES STANDARD DRAWINGS

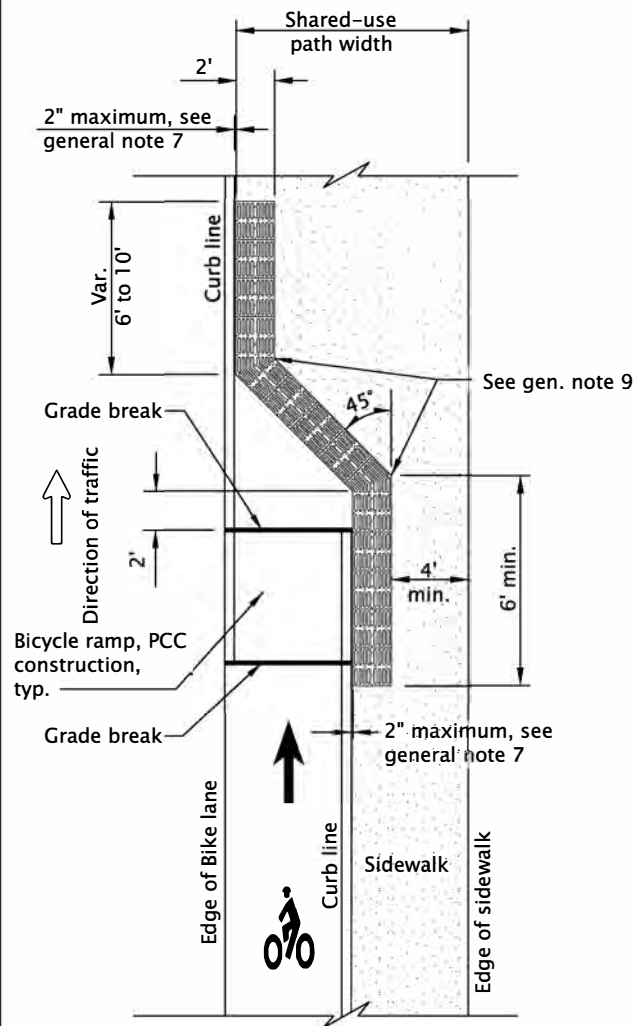
DETECTABLE WARNING SURFACE PLACEMENT FOR RAIL

2025

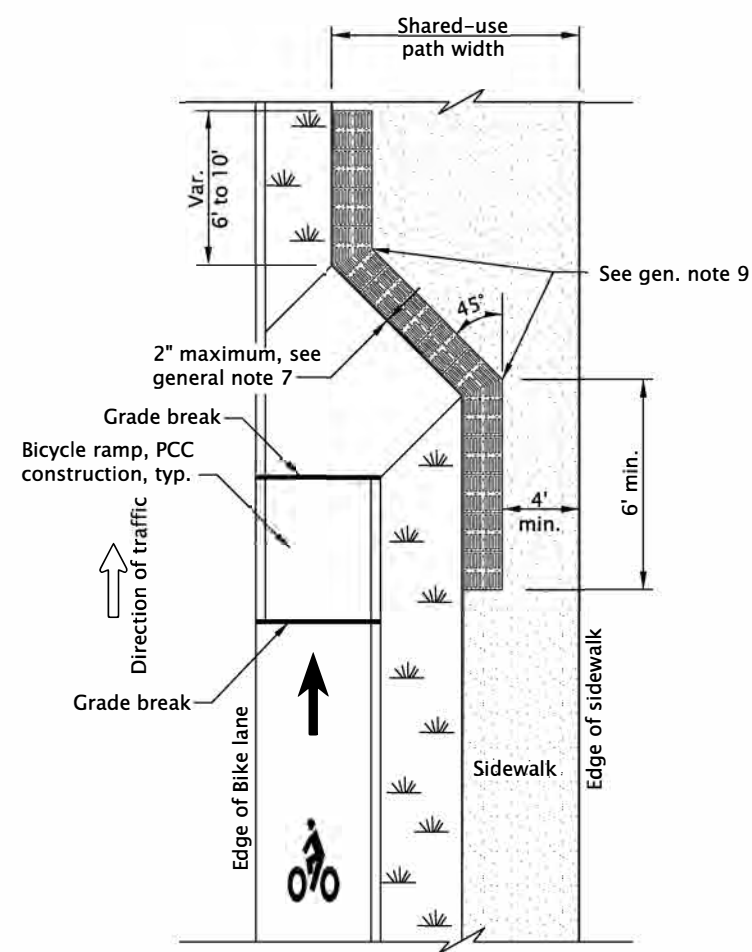
DATE	REVISION DESCRIPTION
07-2020	NEW DRAWING CREATED
07-2022	REVISED DETAILS AND NOTES

CALC. BOOK NO.	N/A	SDR DATE	15-JUL-2022	RD908
----------------	-----	----------	-------------	--------------

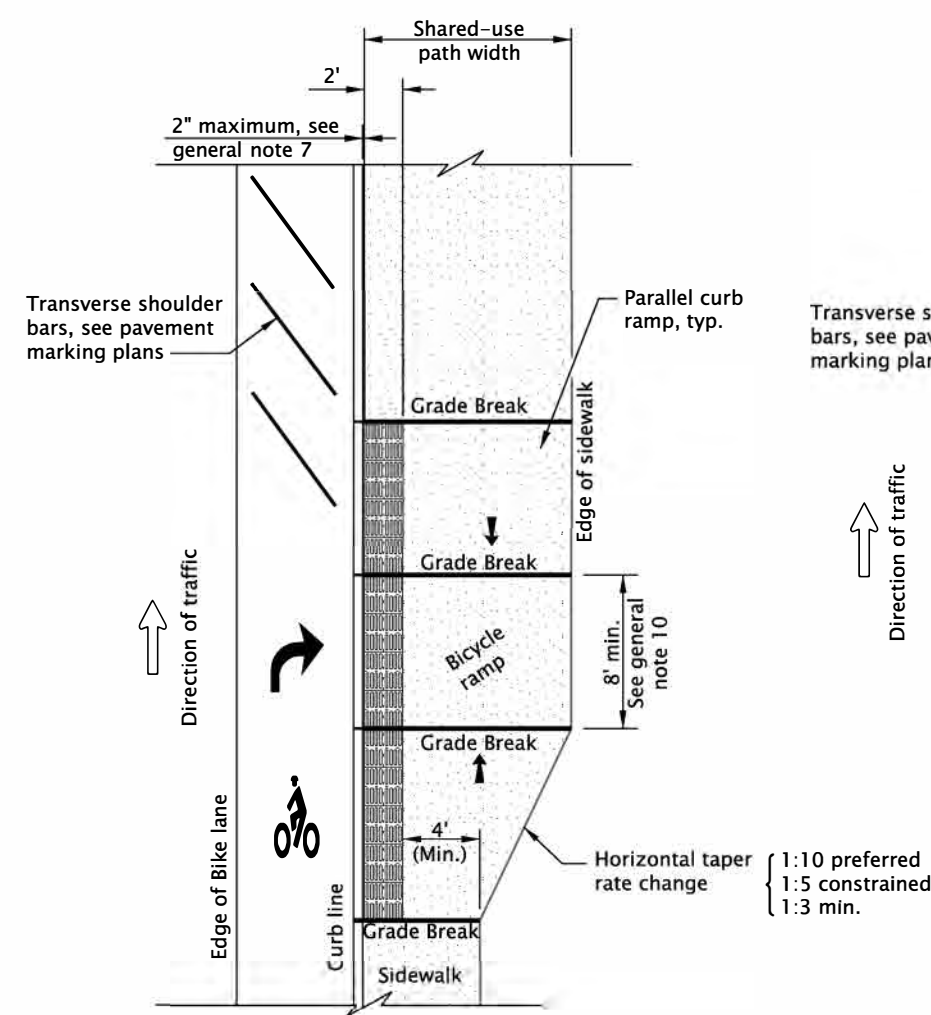
RD909.dgn 14-JAN-2022



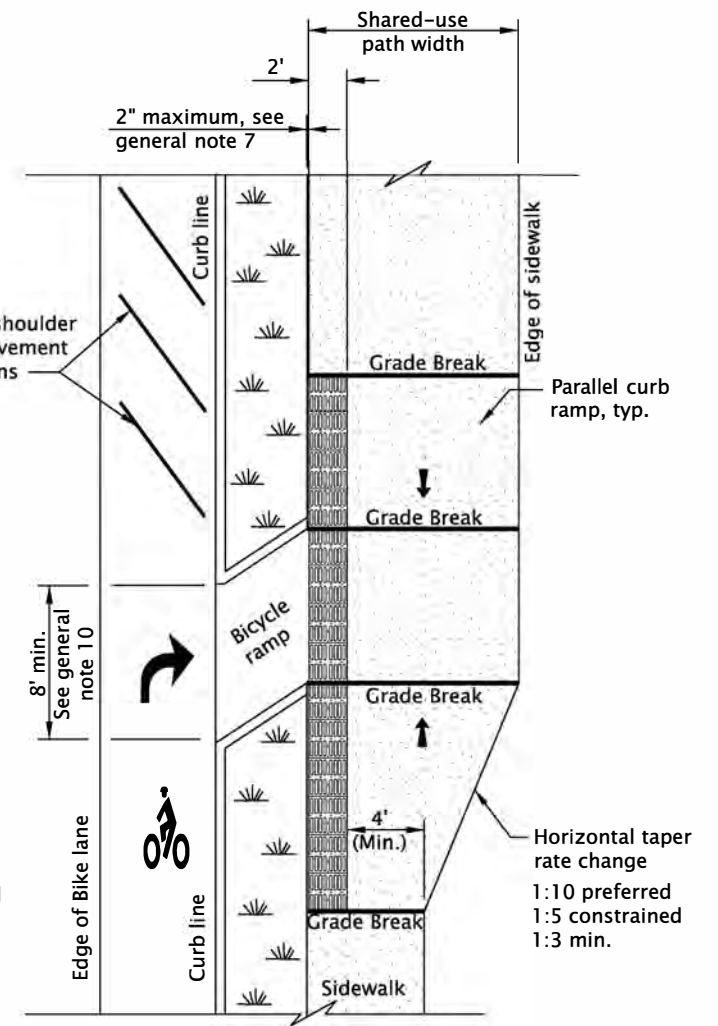
OPTION "BR-1"
BICYCLE LANE DROP TO CURB LINE SIDEWALK



OPTION "BR-2"
BICYCLE LANE DROP TO SEPARATED SIDEWALK



OPTION "BR-3"
BICYCLE LANE PARALLEL RAMP APPROACH



OPTION "BR-4"
BICYCLE LANE ANGLED RAMP APPROACH

LEGEND:

- Detectable guide strip
- Sidewalk
- Running slope 7.5% maximum (maximum 8.3% finished surface slope)

GENERAL NOTES FOR ALL DETAILS ON THIS SHEET:

1. Bicycle ramp details are based on applicable COTD Standards. If curb ramp serves both bicycles and pedestrians, do not use this drawing. See Std. Dwg. RD902.
2. See project plans for details not shown. See Std. Dwgs. RD700 and RD702 for curbs. See Std. Dwgs. RD720 & RD721 for sidewalks. See Std. Dwg. RD920 for parallel curb ramp details. See Std. Dwg. RD1140 for separated bike lanes. See Std. Dwg. TM500 for transverse shoulder bars details.
3. Site conditions normally require a project specific design. See project plans for details not shown.
4. Curb ramps for shared use paths intersecting a roadway shall be full width of path, excluding flares.

5. Detectable guide strip color shall be blue if no color specified. Color shall be contrasting to the surrounding area, light on dark, or dark on light. Blue markings are reserved for accessibility features. Alternative colors require a design exception on or along state highways.
6. Agency review and approval required for detectable guide strip products.
7. Detectable guide strip shall be placed a maximum of 2-inches from the edge of the sidewalk.
8. Place abutting panels within 1/4-inch of each other and install anchors, as specified by manufacturers, along cut edge.
9. Miter panels at 45 degree angle. Detectable guide strips may be cut to meet necessary shape as shown.
10. When a curb ramp is used to provide bicycle access from a roadway to a sidewalk, the curb ramp opening will be ≥ 8' wide.

All materials shall be in accordance with the current City of The Dalles Standard Specifications.

CITY OF THE DALLES STANDARD DRAWINGS

DETECTABLE GUIDE STRIP PLACEMENT AT BIKE RAMPS

2025

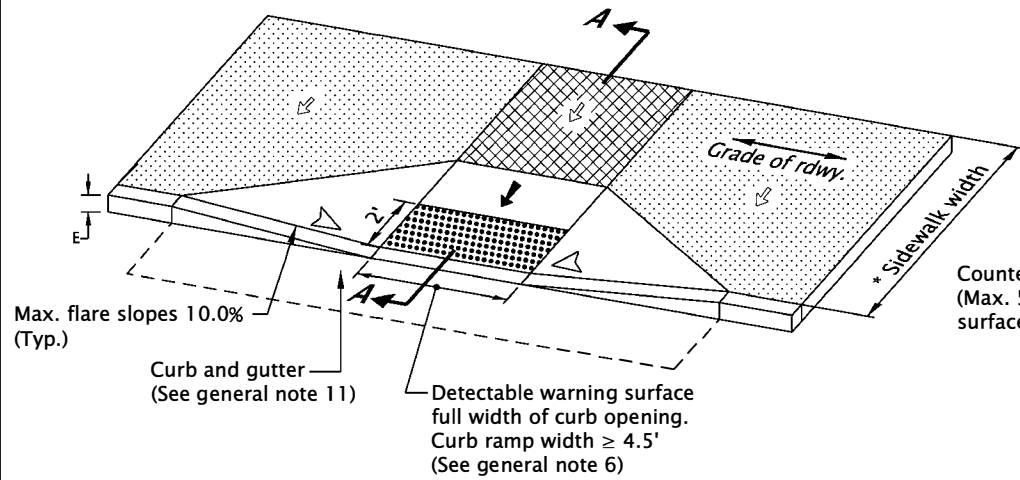
DATE	REVISION	DESCRIPTION
12-2021	NEW DRAWING CREATED	

CALC. BOOK NO. N/A
SDR DATE 14-JAN-2022
RD909

Effective Date: January 1, 2025 – December 31, 2025

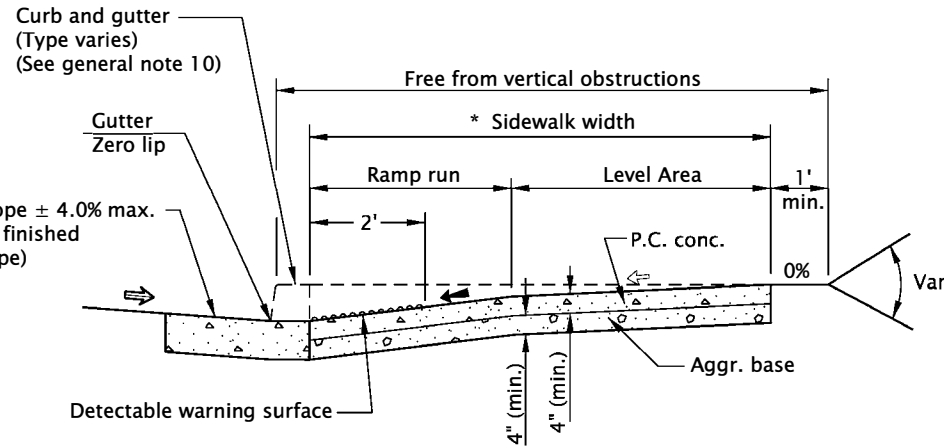
14-JAN-2022

RD910.dgn



PERPENDICULAR CURB RAMP DETAIL

(Use "Parallel Curb Ramp Detail" or "Combination Curb Ramp Detail" when reqd. turning space cannot be obtained)



SECTION A-A

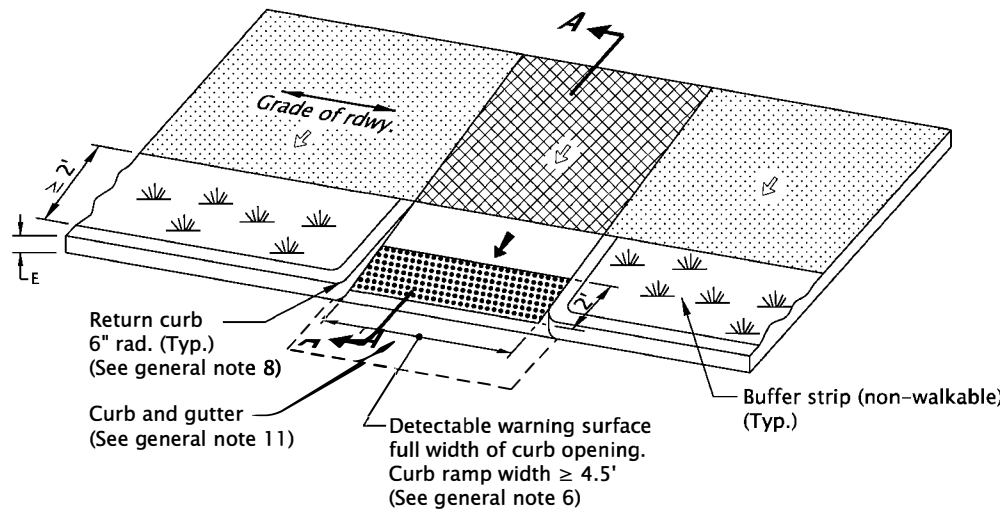
* NOTE: Minimum width of 14.25 feet sidewalk for E=7"

GENERAL NOTES FOR ALL DETAILS ON THIS SHEET:

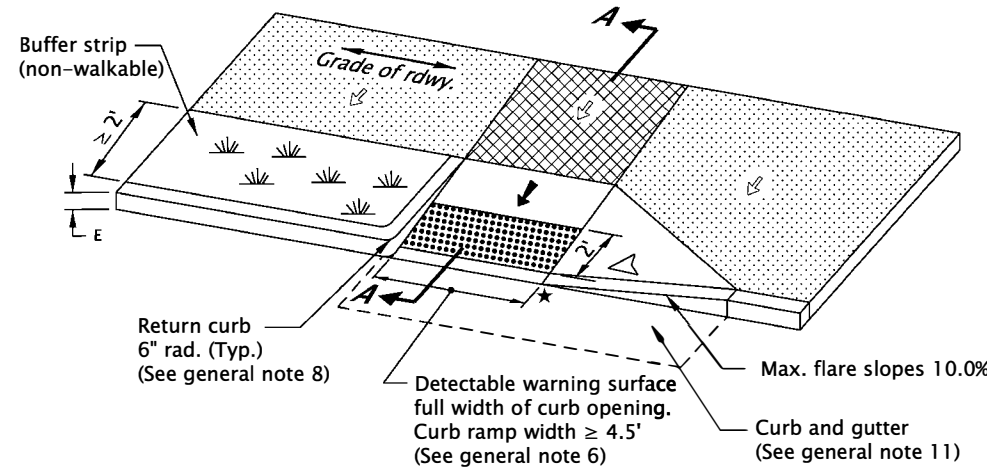
1. Curb ramp details are based on applicable COTD Standards.
2. See Std. Dwgs. RD700 & RD701 for curbs.
See Std. Dwgs. RD720 & RD721 for sidewalks.
See Std. Dwgs. RD902 through RD908 for detectable warning surface installation details.
See Std. Dwgs. RD912 through RD916 for curb ramp placement options.
3. Site conditions normally require a project specific design. See project plans for details not shown.
4. Tooled dummy joints are required at all curb ramp grade break lines, (see Std. Dwg. RD722).
5. Curb ramp slopes shown are relative to the true level horizon (zero bubble).
6. Place detectable warning surface at the back of curb for a minimum depth of 2' in the direction of pedestrian travel full width of curb ramp opening that is adjacent to traffic.
7. Grade breaks at the top and bottom of curb ramp runs shall be perpendicular to the direction of the ramp run. Grade breaks shall not be permitted on the surface of ramp runs and turning spaces. Surface slopes that meet at grade breaks shall be flush.
8. Return curb may be provided in lieu of flared slope only if protected from traverse travel by landscaping, see Std. Dwg. RD721. Return curb shall not reduce width of approaching sidewalk.
9. Curb ramps for shared use paths intersecting a roadway shall be full width of path, excluding flares. When a curb ramp is used to provide bicycle access from a roadway to a sidewalk, the curb ramp opening will be ≥ 8' wide, (see Std. Dwg. RD909 for additional details).
10. Place an inlet at upstream side of curb ramp or perform other approved design mitigation. Check the gutter flow depth at curb ramp locations to assure that the design flood does not overtop the back of sidewalk.
11. Curb and gutter is required at curb ramps.

LEGEND:

- Sidewalk
- Detectable warning surface
- Level area (Turning space/landing)
Unobstructed 4.5' x 4.5'
With obstruction 4.5' x 5.5' (Longer dimension in direction of pedestrian street crossing).
For the purposes of this application, a max. 2.0% finished surface slope (for drainage) measured perpendicular in two directions is considered level.
- Cross slope 1.5% max.
(Max. 2.0% finished surface slope)
(Normal sidewalk cross slope)
- Running slope 7.5% max.
(Max. 8.3% finished surface slope)
- Counter slope 4.0% max. ascending or descending,
(Max. 5.0% finished surface slope)
Slope as required for drainage
- Flare slope
(Max. 10% finished surface slope)



THROUGH BUFFER STRIP

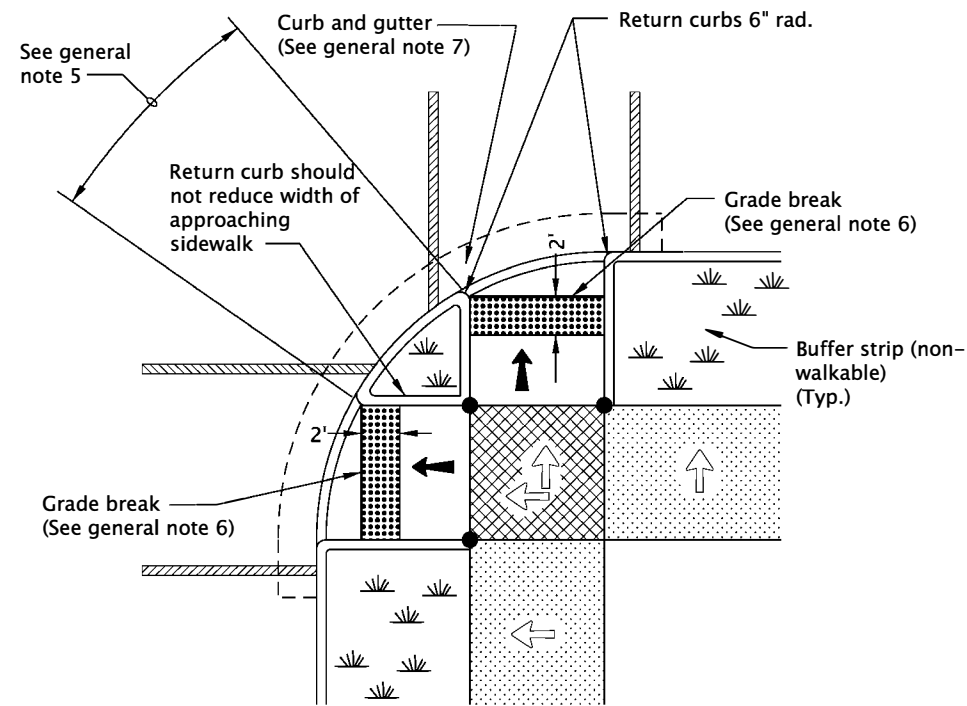


WITH SINGLE FLARE

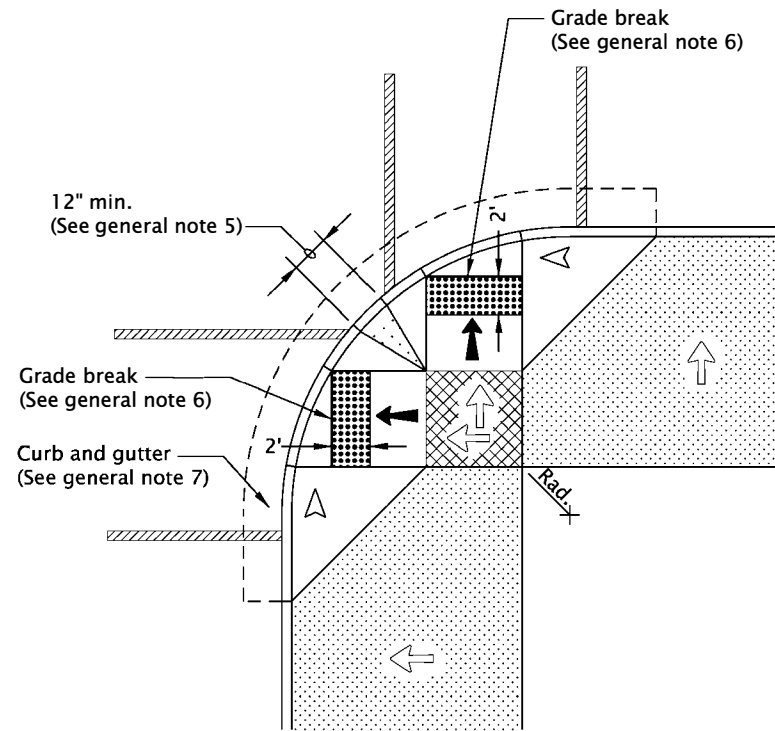
The selection and use of this Standard Drawing, while designed in accordance with generally accepted engineering principles and practices, is the sole responsibility of the user and should not be used without first consulting a Registered Professional Engineer.

All materials shall be in accordance with the current City of The Dalles Standard Specifications.	
CITY OF THE DALLES STANDARD DRAWINGS	
PERPENDICULAR CURB RAMP	
2025	
DATE	REVISION DESCRIPTION
12-2021	NEW DRAWING CREATED
01-2022	REVISED NOTES
CALC. BOOK NO.	SDR DATE 14-JAN-2022
N/A	RD910

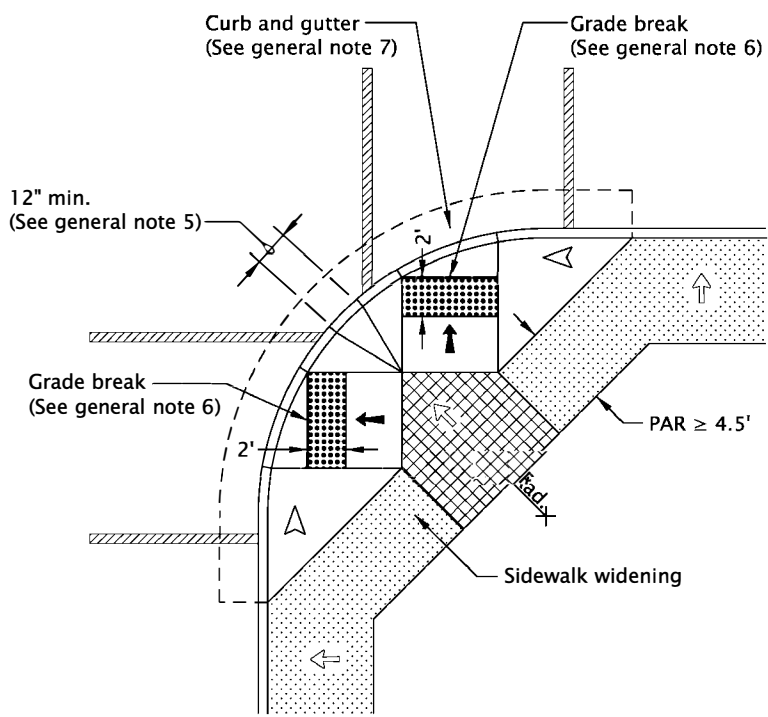
rd912.dgn 19-JUL-2021



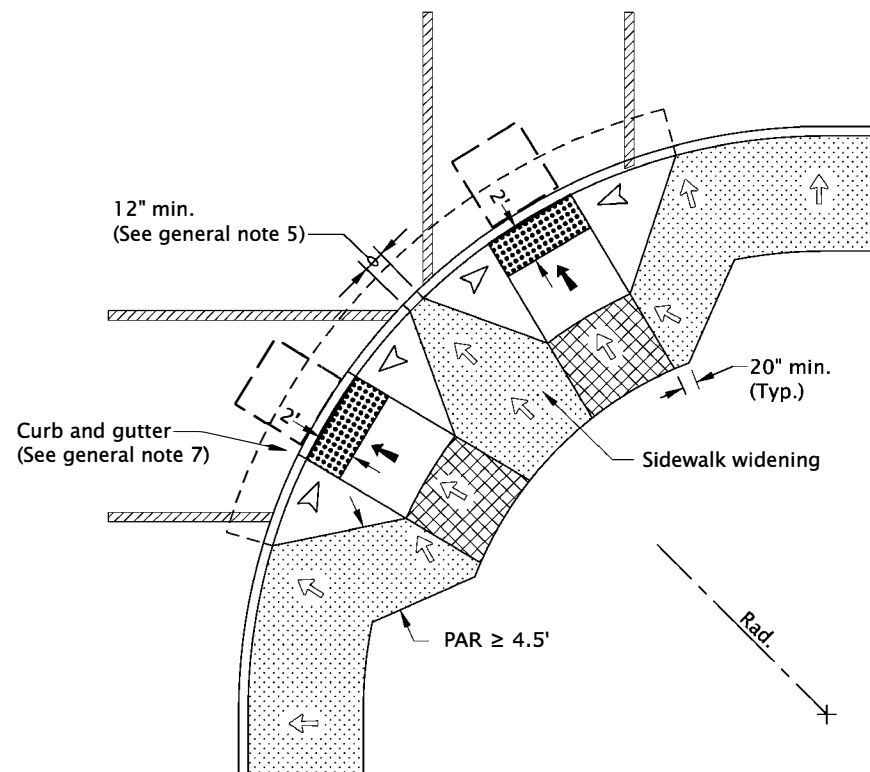
**WITH LANDSCAPED BUFFER STRIP
OPTION "PR-1"**



**FOR WIDE SIDEWALKS
OPTION "PR-2"**



**FOR NARROW SIDEWALKS
OPTION "PR-3"**



**FOR NARROW SIDEWALKS
OPTION "PR-4"**

GENERAL NOTES FOR ALL DETAILS ON THIS SHEET:

1. Curb ramp details are based on applicable COTD Standards. See project plans for details not shown.
2. See Std. Dwgs. RD700 & RD701 for curbs. See Std. Dwgs. RD720 & RD721 for sidewalks. See Std. Dwg. RD910 for perpendicular curb ramp details. See Std. Dwgs. RD902 through RD908 for detectable warning surface installation details.
3. Tooled dummy joints are required at all curb ramp grade break lines, (see Std. Dwg. RD722).
4. Curb ramp slopes shown are relative to the true level horizon (zero bubble).
5. When 2 curb ramps are immediately adjacent, the curb exposure (E) between the adjacent side flares may range between 3" and full design exposure.
6. Grade breaks at the top and bottom of curb ramp runs shall be perpendicular to the direction of the ramp run. Grade breaks shall not be permitted on the surface of ramp runs and turning spaces. Surface slopes that meet at grade breaks shall be flush.
7. Curb and gutter is required at curb ramps.

LEGEND:

- Marked or intended crossing location
- Sidewalk
- Detectable warning surface
- Level area (Turning space/landing)
Unobstructed 4.5' x 4.5'
With obstruction 4.5' x 5.5' (Longer dimension in direction of pedestrian street crossing).
For the purposes of this application, a max. 2.0% finished surface slope (for drainage) measured perpendicular in two directions is considered level.
- Cross slope 1.5% max.
(Max. 2.0% finished surface slope)
(Normal sidewalk cross slope)
- Running slope 7.5% max.
(Max. 8.3% finished surface slope)
- Flare slope
(Max. 10% finished surface slope)
- Zero curb exposure
- 4' x 4' clear space
- PAR Pedestrian Access Route

CALC. BOOK NO. N/A

SDR DATE 19-JUL-2021

NOTE: All material and workmanship shall be in accordance with the current City of The Dalles Standard Specifications

CITY OF THE DALLES STANDARD DRAWINGS

PERPENDICULAR CURB RAMP

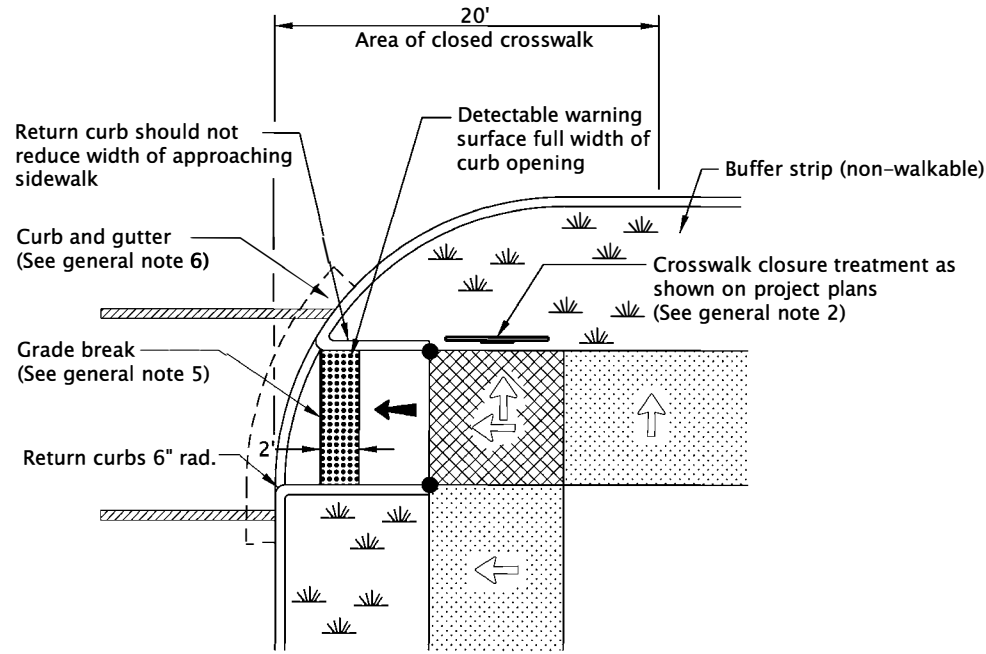
2025

DATE	REVISION	DESCRIPTION
07-2020	DRAWING CREATED	
07-2021	REVISED DETAIL AND NOTES	

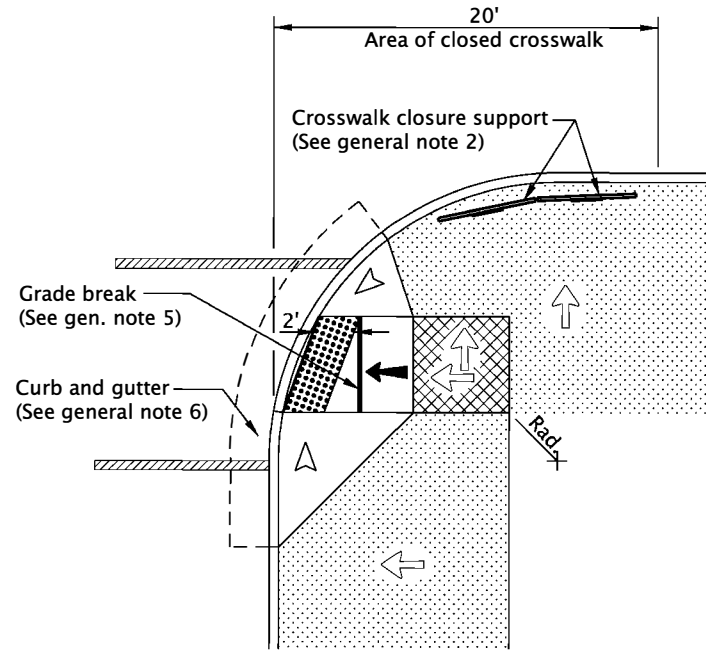
The selection and use of this Standard Drawing, while designed in accordance with generally accepted engineering principles and practices, is the sole responsibility of the user and should not be used without consulting a Registered Professional Engineer.

14-JAN-2022

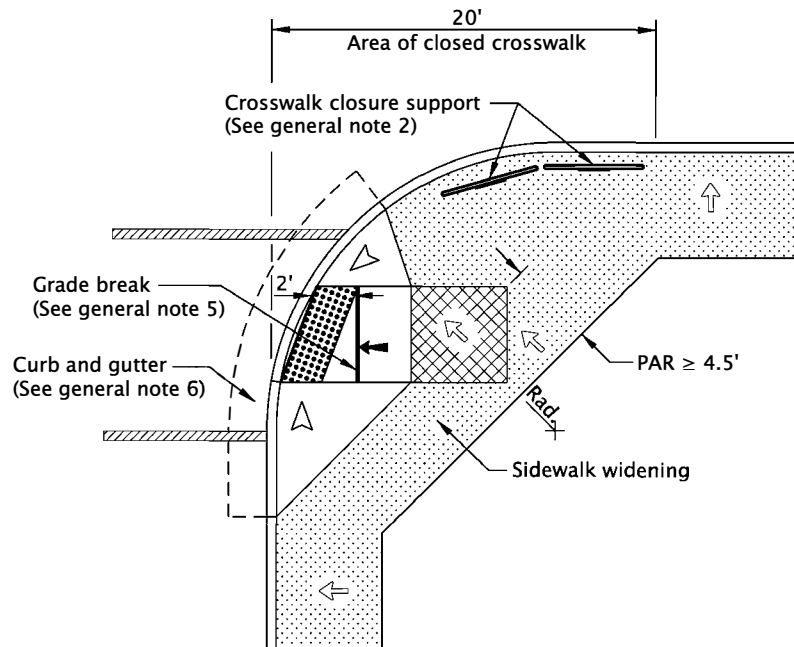
RD913.dgn



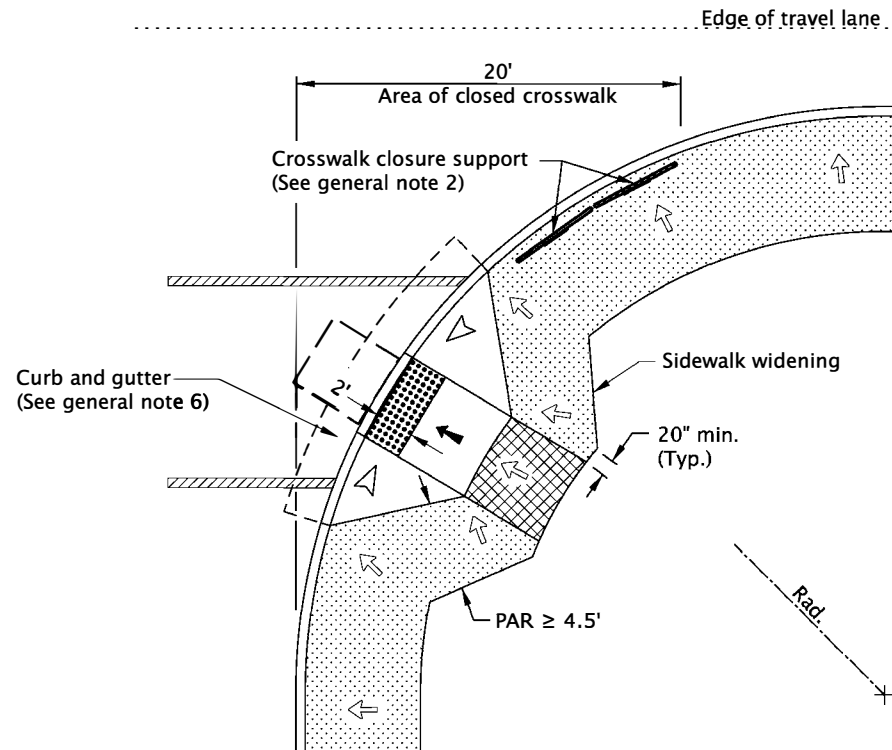
**CROSSWALK CLOSURE WITH LANDSCAPE BUFFER STRIP
OPTION "PR-5"**



**CROSSWALK CLOSURE FOR WIDE SIDEWALK
OPTION "PR-6"**



**CROSSWALK CLOSURE FOR NARROW SIDEWALK
OPTION "PR-7"**



**CROSSWALK CLOSURE
OPTION "PR-8"**

GENERAL NOTES FOR ALL DETAILS ON THIS SHEET:

1. Curb ramp details are based on applicable COTD Standards.
2. See project plans for details not shown.
See Std. Dwgs. RD700 & RD701 for curbs.
See Std. Dwgs. RD720 & RD721 for sidewalks.
See Std. Dwg. RD910 for perpendicular curb ramp details.
See Std. Dwgs. RD902 through RD908 for detectable warning surface installation details.
See Std. Dwg. TM240 for crosswalk closure detail.
3. Tooled dummy joints are required at all curb ramp grade break lines, (see Std. Dwg. RD722).
4. Curb ramp slopes shown are relative to the true level horizon (zero bubble).
5. Grade breaks at the top and bottom of curb ramp runs shall be perpendicular to the direction of the ramp run. Grade breaks shall not be permitted on the surface of ramp runs and turning spaces. Surface slopes that meet at grade breaks shall be flush.
6. Curb and gutter is required at curb ramps.

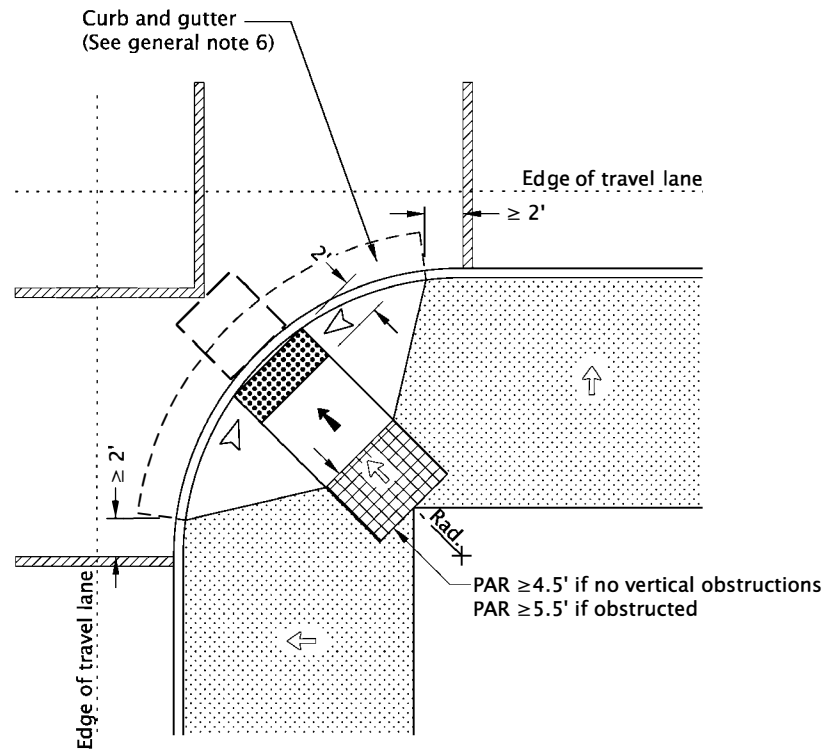
LEGEND:

- Marked or intended crossing location
- Sidewalk
- Detectable warning surface
- Level area (Turning space/landing)
Unobstructed 4.5' x 4.5'
With obstruction 4.5' x 5.5' (Longer dimension in direction of pedestrian street crossing).
For the purposes of this application, a max. 2.0% finished surface slope (for drainage) measured perpendicular in two directions is considered level.
- Cross slope 1.5% max.
(Max. 2.0% finished surface slope)
(Normal sidewalk cross slope)
- Running slope 7.5% max.
(Max. 8.3% finished surface slope)
- Flare slope
(Max. 10% finished surface slope)
- Zero curb exposure
- 4' x 4' clear space
- PAR Pedestrian Access Route

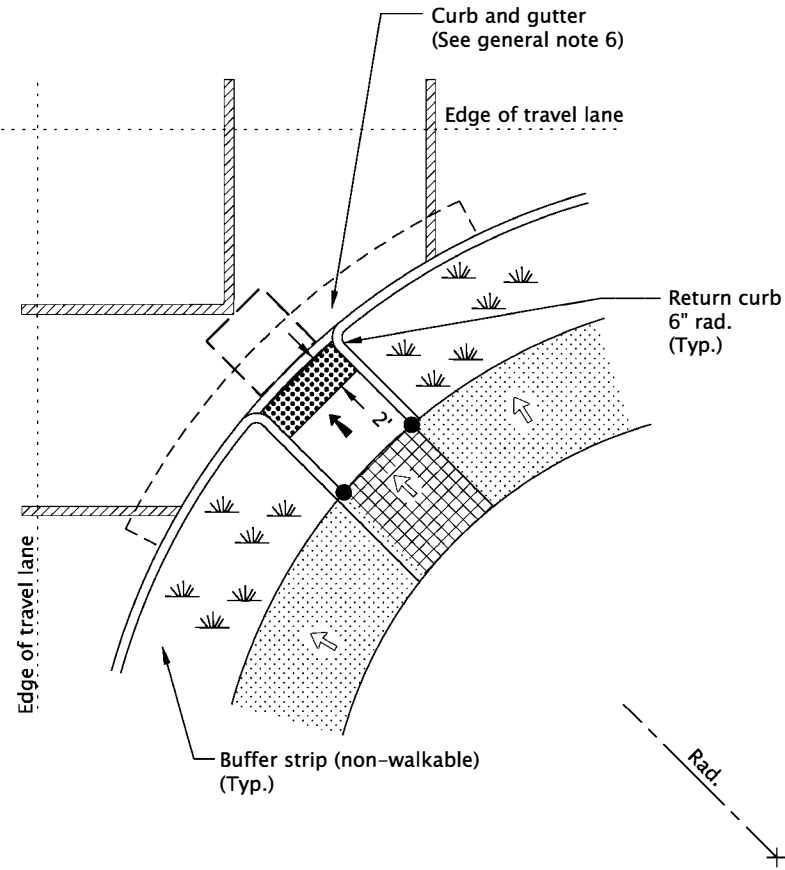
The selection and use of this Standard Drawing, while designed in accordance with generally accepted engineering principles and practices, is the sole responsibility of the user and should not be used without first consulting a Registered Professional Engineer.

All materials shall be in accordance with the current City of The Dalles Standard Specifications.	
CITY OF THE DALLES STANDARD DRAWINGS	
PERPENDICULAR CURB RAMP WITH CLOSURE	
2025	
DATE	REVISION DESCRIPTION
07-2020	NEW DRAWING CREATED
01-2022	REVISED DETAIL AND NOTES
CALC. BOOK NO. --- N/A ---	SDR DATE 14-JAN-2022
	RD913

rd916.dgn 20-JUL-2020



**DIAGONAL CURB RAMP FOR WIDE SIDEWALKS
OPTION "PR-9"**



**DIAGONAL CURB RAMP WITH LANDSCAPED BUFFER STRIP
OPTION "PR-10"**

GENERAL NOTES FOR ALL DETAILS ON THIS SHEET:

1. Curb ramp details are based on applicable COTD Standards.
2. See project plans for details not shown.
See Std. Dwgs. RD700 & RD701 for curbs.
See Std. Dwgs. RD720 & RD721 for sidewalks.
See Std. Dwg. RD910 for perpendicular curb ramp details.
See Std. Dwgs. RD902 through RD908 for detectable warning surface installation details.
3. Tooled dummy joints are required at all curb ramp slope break lines, (see Std. Dwg. RD722).
4. Curb ramp slopes shown are relative to the true level horizon (zero bubble).
5. Only use curb ramp options approved by City.
6. Curb and gutter is required at curb ramps.

LEGEND:

- Marked or intended crossing location
- Sidewalk
- Detectable warning surface
- Level area (Turning space/landing)
Unobstructed 4.5' x 4.5'
With obstruction 4.5' x 5.5' (Longer dimension in direction of pedestrian street crossing).
For the purposes of this application, a max. 2.0% finished surface slope (for drainage) measured perpendicular in two directions is considered level.
- Cross slope 1.5% max.
(Max. 2.0% finished surface slope)
(Normal sidewalk cross slope)
- Running slope 7.5% max.
(Max. 8.3% finished surface slope)
- Flare slope
(Max. 10% finished surface slope)
- 4'x4' clear space
- PAR Pedestrian Access Route
- Zero curb exposure

CALC. BOOK NO. N/A

SDR DATE 20-JULY-2020

NOTE: All material and workmanship shall be in accordance with the current City of The Dalles Standard Specifications

CITY OF THE DALLES STANDARD DRAWINGS

**PERPENDICULAR CURB RAMP
SINGLE RAMP**

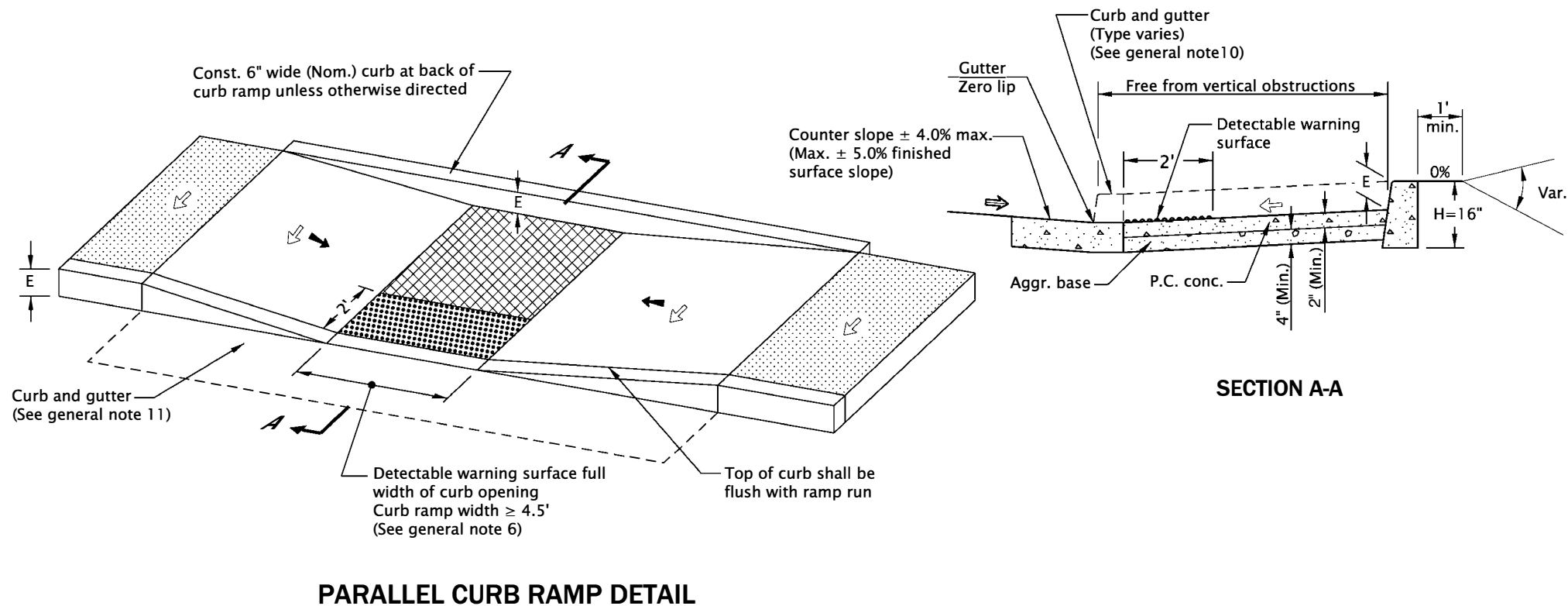
2025

DATE	REVISION	DESCRIPTION
07-2020	DRAWING CREATED	

The selection and use of this Standard Drawing, while designed in accordance with generally accepted engineering principles and practices, is the sole responsibility of the user and should not be used without consulting a Registered Professional Engineer.

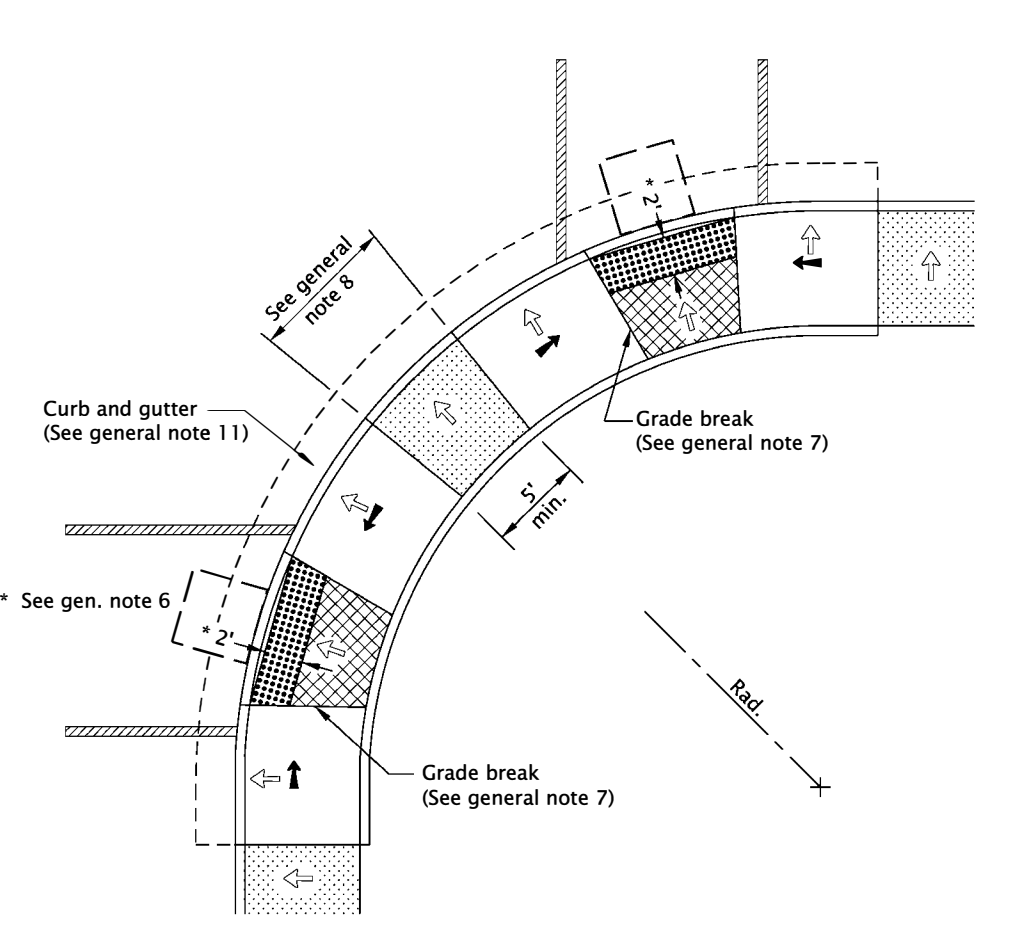
RD916

rd920.dgn 19-JUL-2021

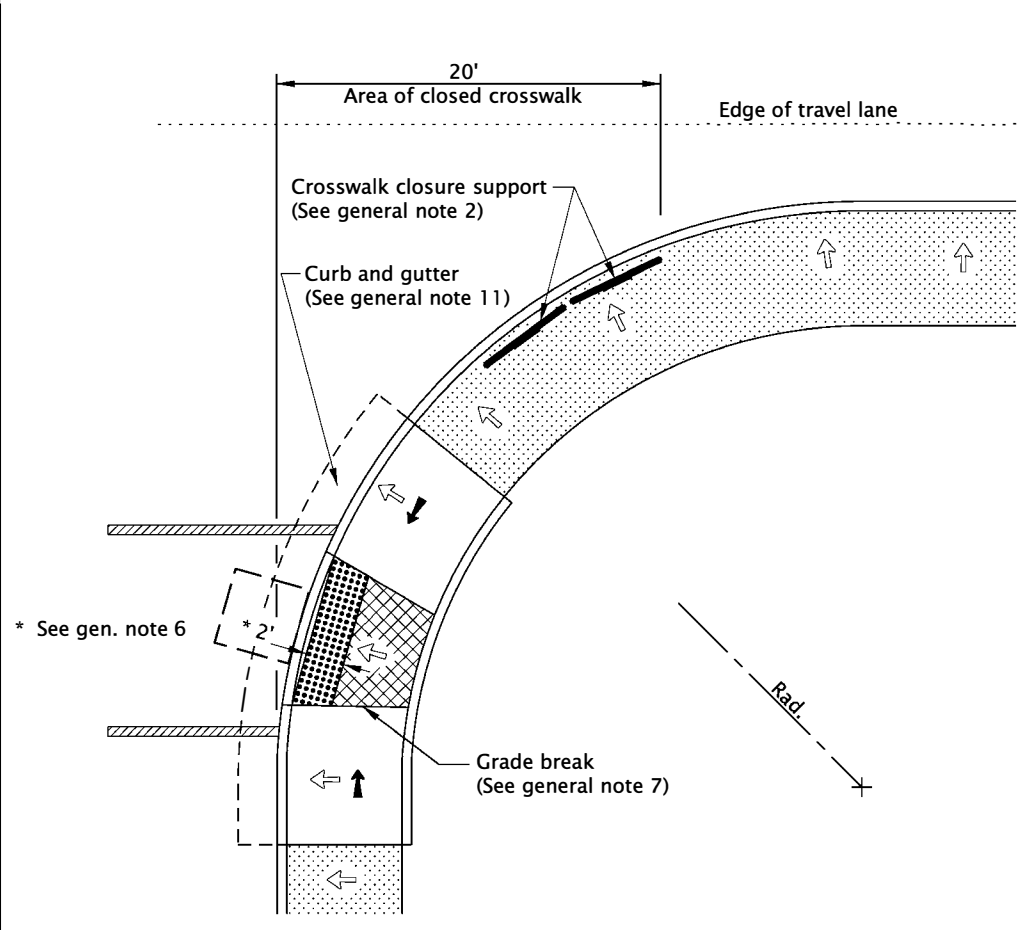


PARALLEL CURB RAMP DETAIL

- GENERAL NOTES FOR ALL DETAILS ON THIS SHEET:**
1. Curb ramp details are based on applicable COTD Standards.
 2. See Std. Dwgs. RD700 & RD701 for curbs. See Std. Dwgs. RD720 & RD721 for sidewalks. See Std. Dwgs. RD902 through RD908 for detectable warning surface installation details. See Std. Dwg. TM240 for crosswalk closure detail.
 3. Site conditions normally require a project specific design. See project plans for details not shown.
 4. Tooled dummy joints are required at all curb ramp grade break lines, (see Std. Dwg. RD722).
 5. Curb ramp slopes shown are relative to the true level horizon (zero bubble).
 6. Place detectable warning surface at the back of curb for a minimum depth of 2' in the direction of pedestrian travel full width of curb ramp opening that is adjacent to traffic.
 7. Grade breaks at the top and bottom of curb ramp runs shall be perpendicular to the direction of the ramp run. Grade breaks shall not be permitted on the surface of ramp runs and turning spaces. Surface slopes that meet at grade breaks shall be flush.
 8. When 2 ramp runs are immediately adjacent, the curb exposure (E) between the adjacent side may range between 3" and full design exposure.
 9. Curb ramps for shared use paths intersecting a roadway shall be full width of path, excluding flares. When a curb ramp is used to provide bicycle access from a roadway to a sidewalk, the curb ramp opening will be ≥ 8' wide.
 10. Place an inlet at upstream side of curb ramp or perform other approved design mitigation. Check the gutter flow depth at curb ramp locations to assure that the design flood does not overtop the back of sidewalk.
 11. Curb and gutter is required at curb ramps.



PARALLEL CURB RAMPS OPTION "PL-1"



PARALLEL CURB RAMP WITH CROSSWALK CLOSURE OPTION "PL-2"

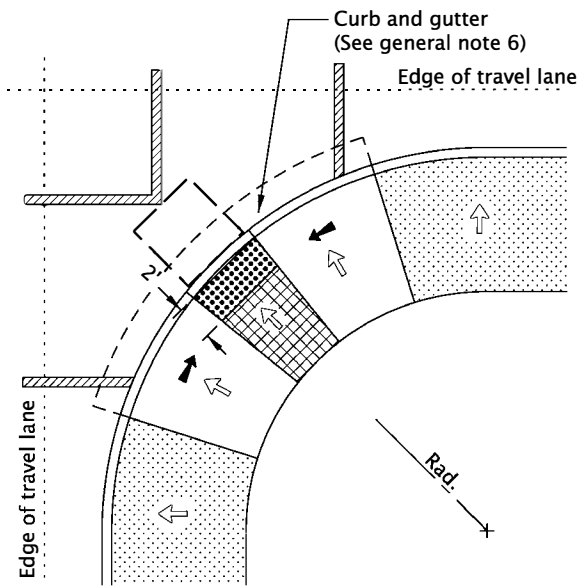
LEGEND:

- Sidewalk
- Detectable warning surface
- Level area (Turning space/landing)
Unobstructed 4.5' x 4.5'
With obstruction 4.5' x 5.5' (Longer dimension in direction of pedestrian street crossing).
For the purposes of this application, a max. 2.0% finished surface slope (for drainage) measured perpendicular in two directions is considered level.
- Cross slope 1.5% max.
(Max. 2.0% finished surface slope)
(Normal sidewalk cross slope)
- Running slope 7.5% max.
(Max. 8.3% finished surface slope)
- Counter slope 4.0% max. ascending or descending,
(Max. 5.0% finished surface slope)
Slope as required for drainage
- 4'x4' clear space

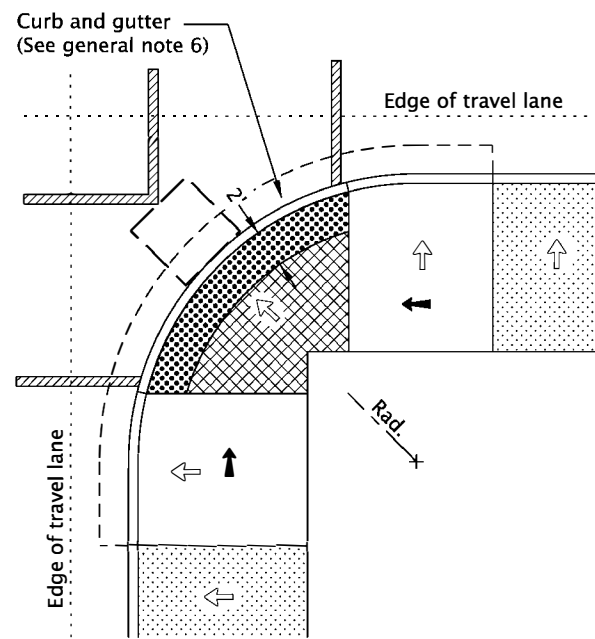
CALC. BOOK NO.	N/A	SDR DATE	19-JUL-2021
NOTE: All material and workmanship shall be in accordance with the current City of The Dalles Standard Specifications			
CITY OF THE DALLES STANDARD DRAWINGS			
PARALLEL CURB RAMP			
2025			
DATE	REVISION	DESCRIPTION	
07-2020	DRAWING CREATED		
07-2021	REVISED DETAIL AND NOTES		

The selection and use of this Standard Drawing, while designed in accordance with generally accepted engineering principles and practices, is the sole responsibility of the user and should not be used without consulting a Registered Professional Engineer.

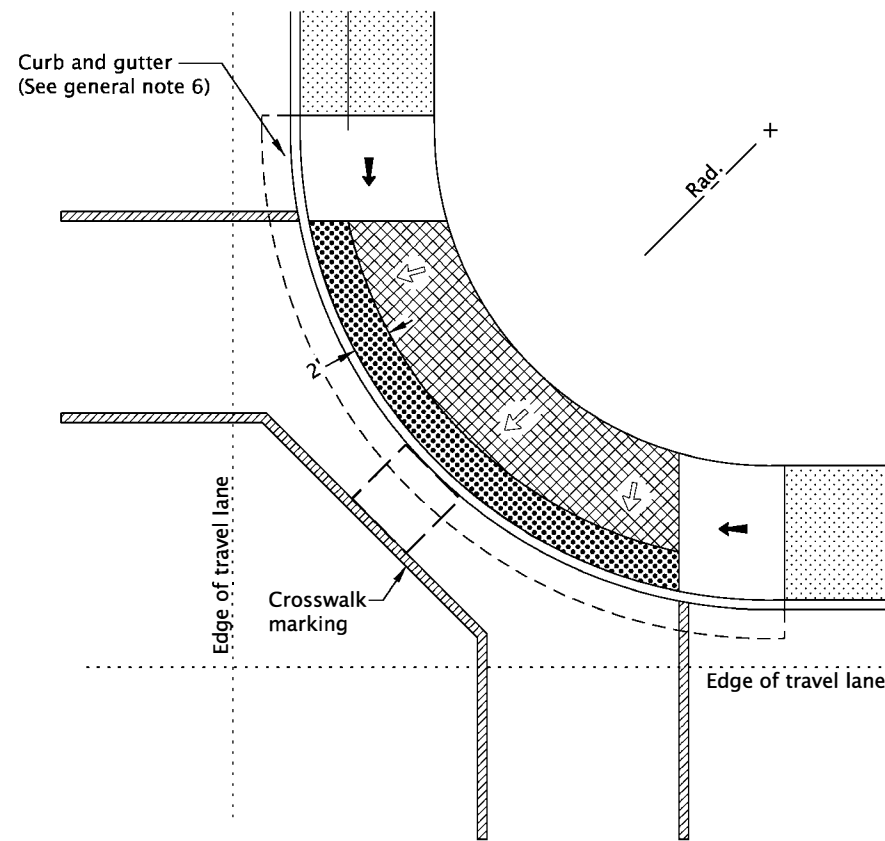
rd922.dgn 20-JUL-2020



**DIAGONAL PARALLEL CURB RAMP
OPTION "PL-3"**



**DEPRESSED CURB RAMP SMALL RADIUS
OPTION "PL-4"**










**DEPRESSED CURB RAMP LARGE RADIUS
OPTION "PL-5"**

GENERAL NOTES FOR ALL DETAILS ON THIS SHEET:

1. Curb ramp details are based on applicable COTD Standards.
2. See project plans for details not shown.
See Std. Dwgs. RD700 & RD701 for curbs.
See Std. Dwgs. RD720 & RD721 for sidewalks.
See Std. Dwgs. RD902 through RD908 for detectable warning surface installation details.
See Std. Dwg. RD920 for parallel curb ramp details.
3. Tooled dummy joints are required at all curb ramp slope break lines, (see Std. Dwg. RD722).
4. Curb ramp slopes shown are relative to the true level horizon (zero bubble).
5. Place an inlet at upstream side of curb ramp or perform other approved design mitigation.
Check the gutter flow depth at curb ramp locations to assure that the design flood does not overtop the back of sidewalk.
6. Curb and gutter is required at curb ramps.
7. Grade breaks at the top and bottom of curb ramp runs shall be perpendicular to the direction of the ramp run. Grade breaks shall not be permitted on the surface of ramp runs and turning spaces. Surface slopes that meet at grade breaks shall be flush.
8. Only use curb ramp options approved by City

LEGEND:

-  Marked or intended crossing location
-  Sidewalk
-  Detectable warning surface
-  Level area (Turning space/landing)
Unobstructed 4.5' x 4.5'
With obstruction 4.5' x 5.5' (Longer dimension in direction of pedestrian street crossing).
For the purposes of this application, a max. 2.0% finished surface slope (for drainage) measured perpendicular in two directions is considered level.
-  Cross slope 1.5% max.
(Max. 2.0% finished surface slope)
(Normal sidewalk cross slope)
-  Running slope 7.5% max.
(Max. 8.3% finished surface slope)
-  4'x4' clear space

CALC. BOOK NO. N/A

SDR DATE 20-JULY-2020

NOTE: All material and workmanship shall be in accordance with the current City of The Dalles Standard Specifications

**CITY OF THE DALLES STANDARD DRAWINGS
PARALLEL CURB RAMP SINGLE
RAMP**

2025

DATE	REVISION	DESCRIPTION
07-2020	DRAWING CREATED	

The selection and use of this Standard Drawing, while designed in accordance with generally accepted engineering principles and practices, is the sole responsibility of the user and should not be used without consulting a Registered Professional Engineer.

RD922









14-JAN-2022

RD930.dgn

GENERAL NOTES FOR ALL DETAILS ON THIS SHEET:

1. Curb ramp details are based on applicable COTD Standards.
2. See project plans for details not shown.
See Std. Dwgs. RD700 & RD701 for curbs.
See Std. Dwgs. RD720 & RD721 for sidewalks.
See Std. Dwgs. RD902 through RD908 for detectable warning surface installation details.
3. Site conditions normally require a project specific design. See project plans for details not shown.
4. Tooled dummy joints are required at all curb ramp slope break lines, (see Std. Dwg. RD722).
5. Curb ramp slopes shown are relative to the true level horizon (zero bubble).
6. Place detectable warning surface at the back of curb for a minimum depth of 2' in the direction of pedestrian travel full width of curb ramp opening that is adjacent to traffic.
7. Place an inlet at upstream side of curb ramp or perform other approved design mitigation. Check the gutter flow depth at curb ramp locations to assure that the design flood does not overtop the back of sidewalk.
8. Return curb may be provided in lieu of flared slope only if protected from traverse travel by landscaping, see Std. Dwg. RD721. Return curb shall not reduce width of approaching sidewalk.
9. Curb ramps for shared use paths intersecting a roadway shall be full width of path, excluding flares. When a curb ramp is used to provide bicycle access from a roadway to a sidewalk, the curb ramp opening will be $\geq 8'$ wide, (see Std. Dwg. RD909 for additional details).
10. On or along state highways, curb and gutter is required at curb ramps.
11. Grade breaks at the top and bottom of curb ramp runs shall be perpendicular to the direction of the ramp run. Grade breaks shall not be permitted on the surface of ramp runs and turning spaces. Surface slopes that meet at grade breaks shall be flush.

LEGEND:

-  Marked or intended crossing location
-  Sidewalk
-  Detectable warning surface
-  Level area (Turning space/landing)
Unobstructed 4.5' x 4.5'
With obstruction 4.5' x 5.5' (Longer dimension in direction of pedestrian street crossing).
For the purposes of this application, a max. 2.0% finished surface slope (for drainage) measured perpendicular in two directions is considered level.
-  Cross slope 1.5% max.
(Max. 2.0% finished surface slope)
(Normal sidewalk cross slope)
-  Running slope 7.5% max.
(Max. 8.3% finished surface slope)
-  Counter slope 4.0% max. ascending or descending,
(Max. 5.0% finished surface slope)
Slope as required for drainage
-  Flare slope
(Max. 10% finished surface slope)

The selection and use of this Standard Drawing, while designed in accordance with generally accepted engineering principles and practices, is the sole responsibility of the user and should not be used without first consulting a Registered Professional Engineer.

All materials shall be in accordance with the current City of The Dalles Standard Specifications.

CITY OF THE DALLES STANDARD DRAWINGS

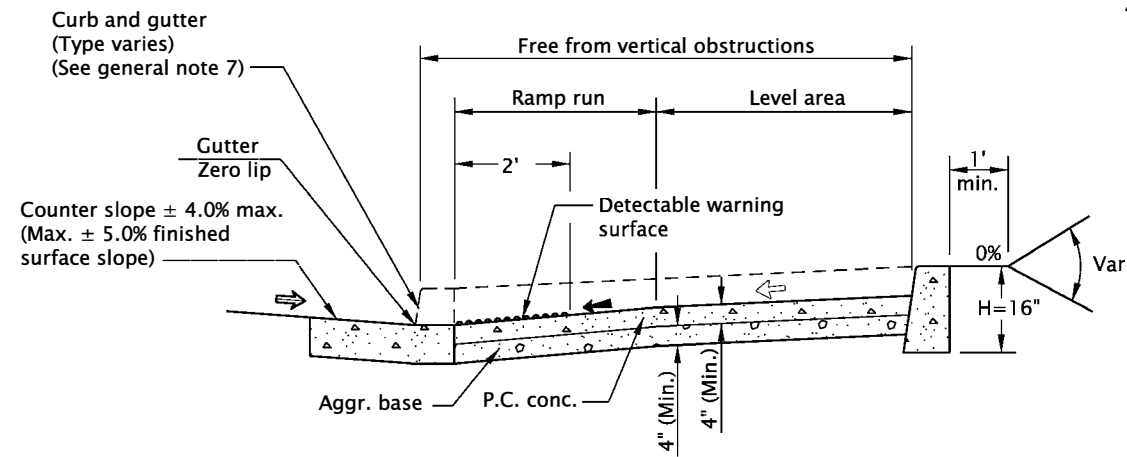
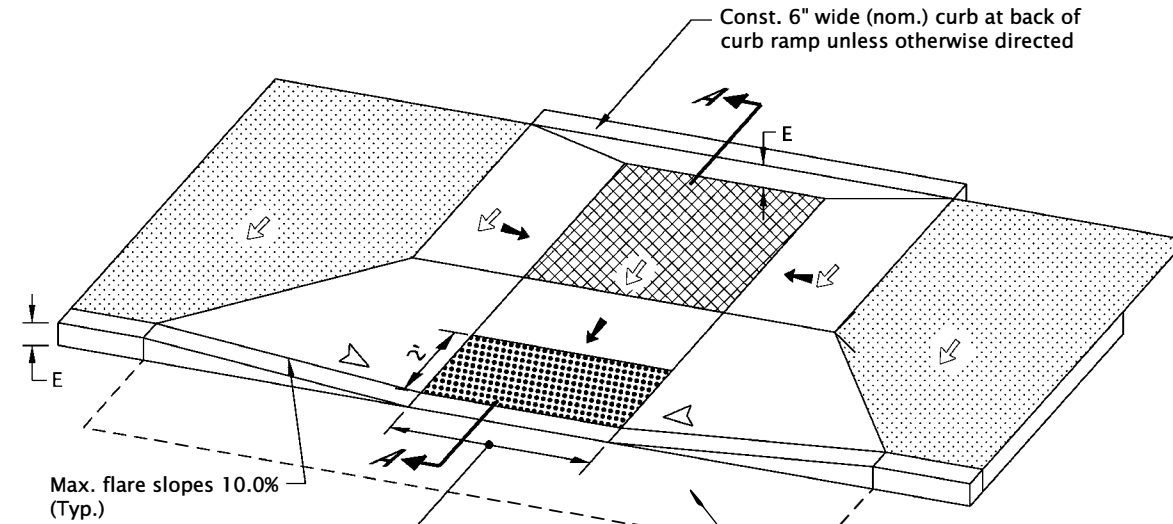
COMBINATION CURB RAMP

2025

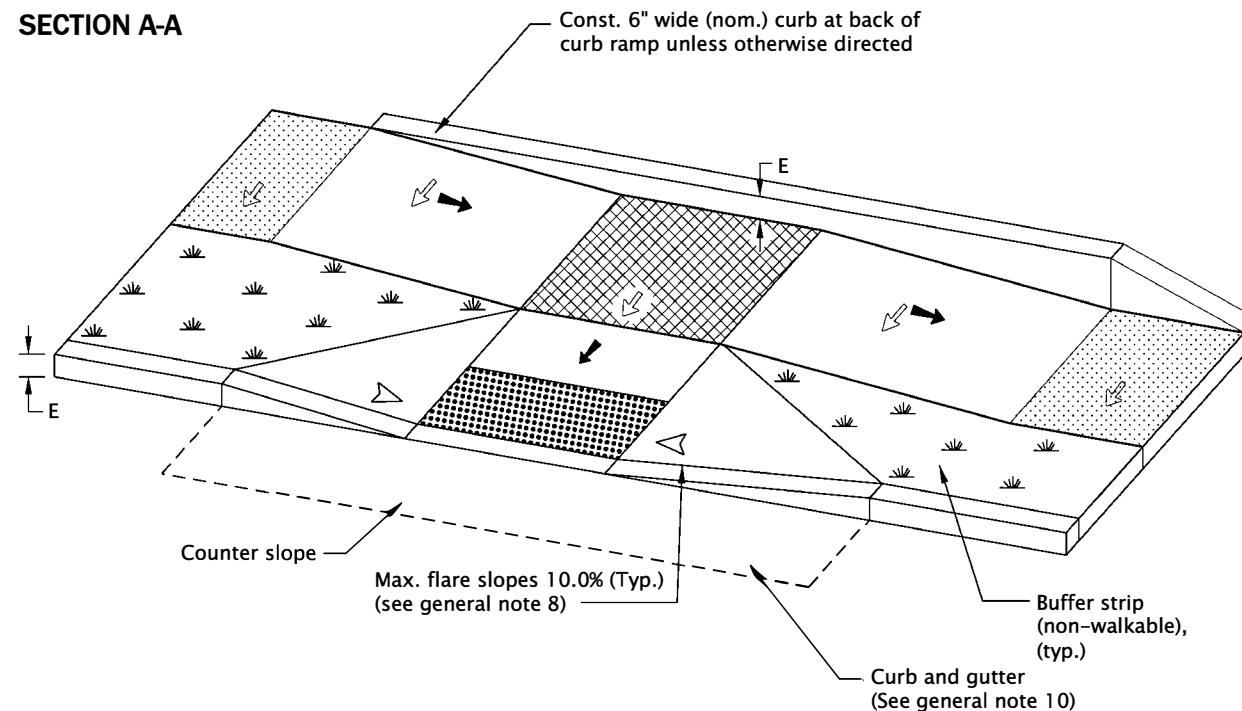
DATE	REVISION DESCRIPTION
07-2020	NEW DRAWING CREATED
07-2021	REVISED DETAIL AND NOTES
01-2022	REVISED NOTES

CALC. BOOK NO.	N/A	SDR DATE 14-JAN-2022	RD930
------------------------	---------------	----------------------	-------

Effective Date: January 1, 2025 – December 31, 2025

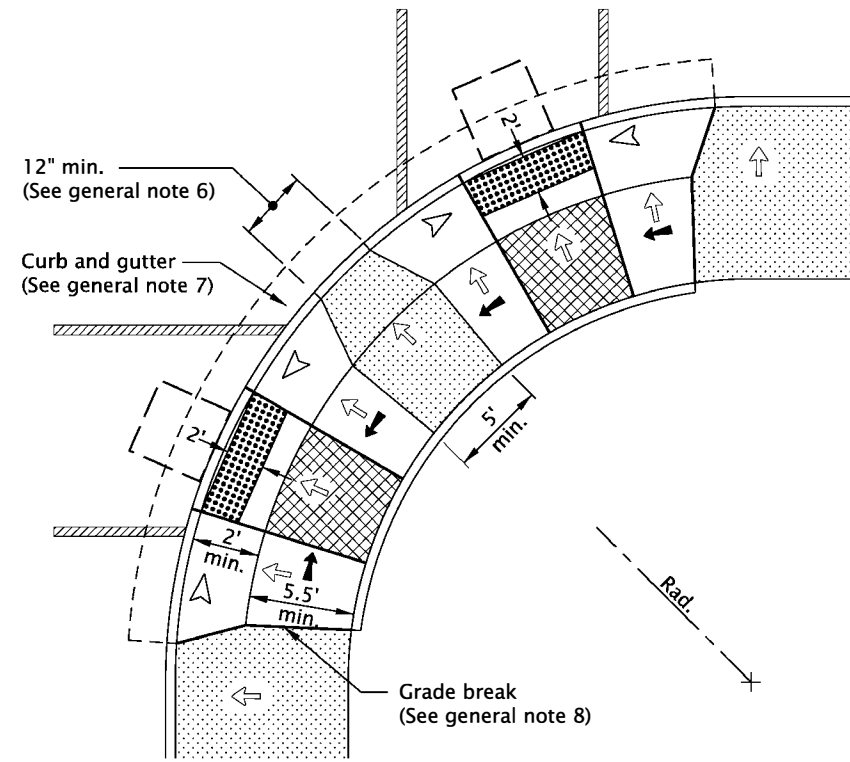


SECTION A-A

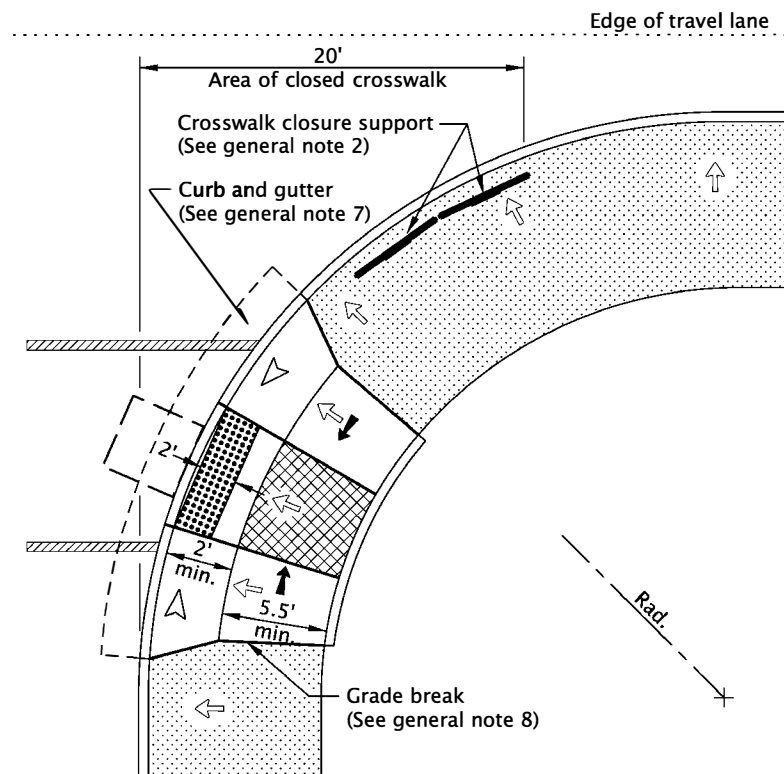


COMBINATION CURB RAMP DETAIL

rd932.dgn 20-JUL-2020



**COMBINATION CURB RAMPS
OPTION "CC-1"**



**COMBINATION CURB RAMP WITH CROSSWALK CLOSURE
OPTION "CC-2"**

GENERAL NOTES FOR ALL DETAILS ON THIS SHEET:

1. Curb ramp details are based on applicable COTD Standards.
2. See project plans for details not shown.
See Std. Dwgs. RD700 & RD701 for curbs.
See Std. Dwgs. RD720 & RD721 for sidewalks.
See Std. Dwgs. RD902 through RD908 for detectable warning surface installation details. See Std. Dwg. RD930 for combination curb ramp details.
See Std. Dwg. TM240 for crosswalk closure detail.
3. Site conditions normally require a project specific design. See project plans for details not shown.
4. Tooled dummy joints are required at all curb ramp slope break lines, (see Std. Dwg. RD722).
5. Curb ramp slopes shown are relative to the true level horizon (zero bubble).
6. When 2 curb ramps are immediately adjacent, the curb exposure (E) between the adjacent side flares may range between 3" and full design exposure.
7. Curb and gutter is required at curb ramps.
8. Grade breaks at the top and bottom of curb ramp runs shall be perpendicular to the direction of the ramp run. Grade breaks shall not be permitted on the surface of ramp runs and turning spaces. Surface slopes that meet at grade breaks shall be flush.

LEGEND:

- Marked or intended crossing location
- Sidewalk
- Detectable warning surface
- Level area (Turning space/landing)
Unobstructed 4.5' x 4.5'
With obstruction 4.5' x 5.5' (Longer dimension in direction of pedestrian street crossing).
For the purposes of this application, a max. 2.0% finished surface slope (for drainage) measured perpendicular in two directions is considered level.
- Cross slope 1.5% max.
(Max. 2.0% finished surface slope)
(Normal sidewalk cross slope)
- Running slope 7.5% max.
(Max. 8.3% finished surface slope)
- Flare slope
(Max. 10% finished surface slope)
- 4'x4' clear space

CALC. BOOK NO. N/A

SDR DATE 20-JULY-2020

NOTE: All material and workmanship shall be in accordance with the current City of The Dalles Standard Specifications

CITY OF THE DALLES STANDARD DRAWINGS

COMBINATION CURB RAMP

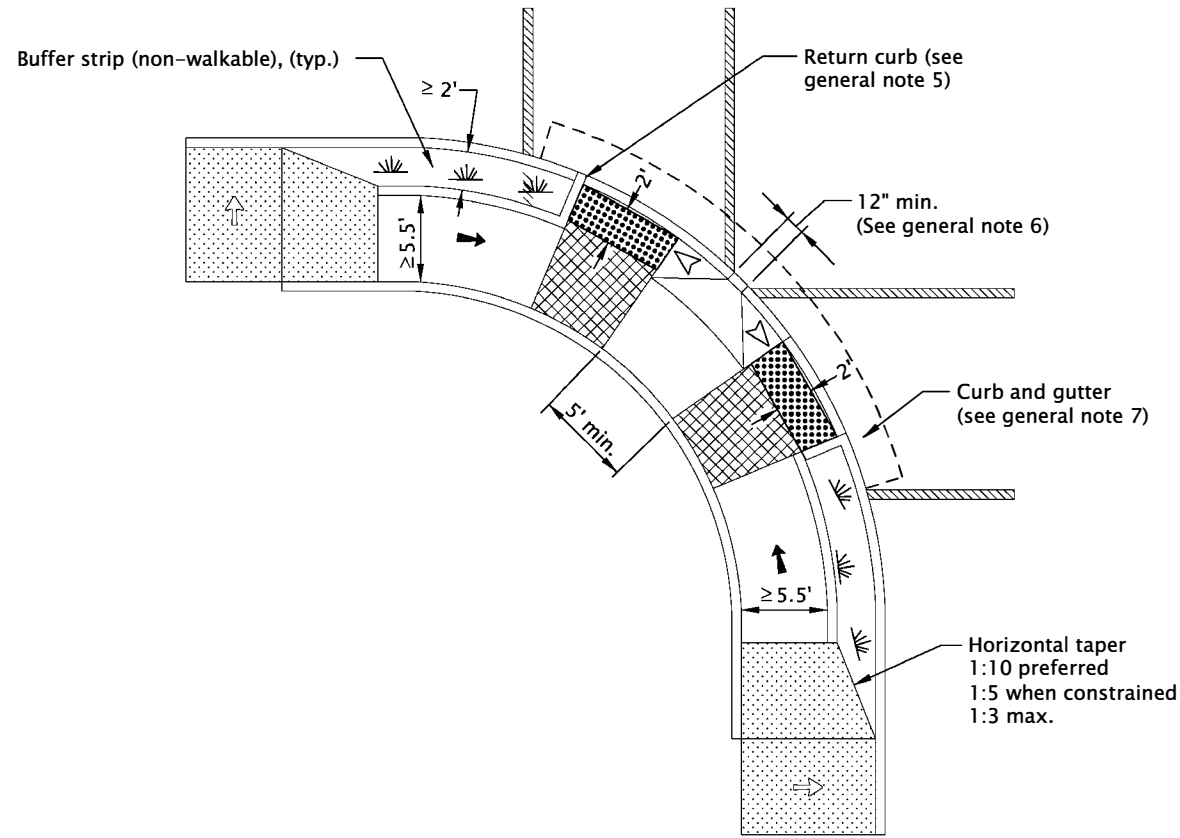
2025

DATE	REVISION	DESCRIPTION
07-2020	DRAWING CREATED	

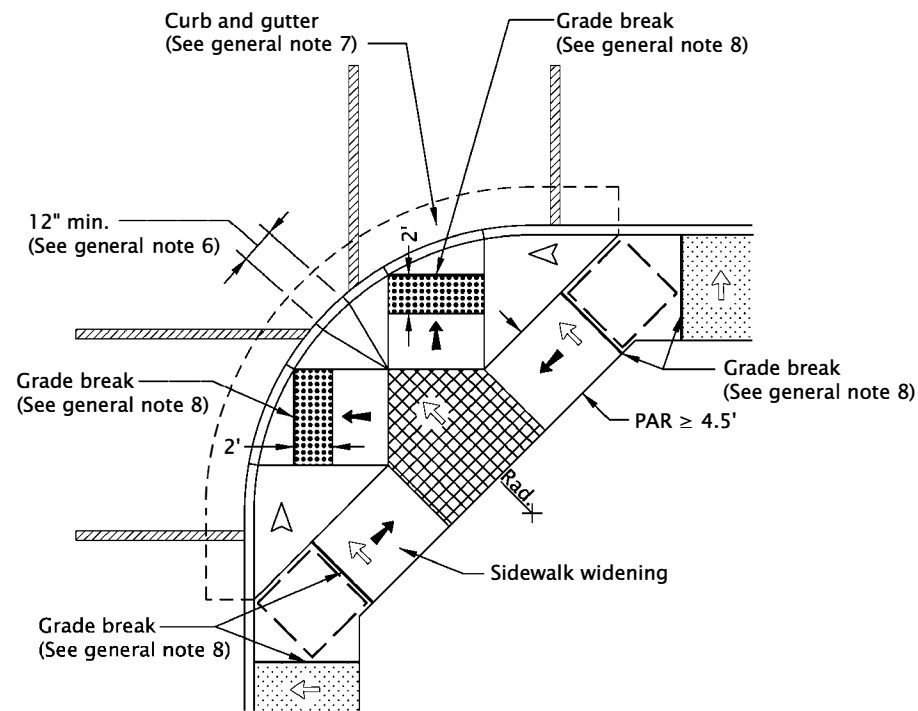
The selection and use of this Standard Drawing, while designed in accordance with generally accepted engineering principles and practices, is the sole responsibility of the user and should not be used without consulting a Registered Professional Engineer.

RD932

rd936.dgn 19-JUL-2021



**PARALLEL COMBINATION WITH LANDSCAPE BUFFER STRIP
OPTION "CC-3"**



**FOR NARROW SIDEWALKS
OPTION "CC-4"**

GENERAL NOTES FOR ALL DETAILS ON THIS SHEET:

1. Curb ramp details are based on applicable COTD Standards.
2. See project plans for details not shown.
See Std. Dwgs. RD700 & RD701 for curbs.
See Std. Dwgs. RD720 & RD721 for sidewalks.
See Std. Dwgs. RD902 through RD908 for detectable warning surface installation details. See Std. Dwg. RD930 for combination curb ramp details.
3. Tooled dummy joints are required at all curb ramp grade break lines, (see Std. Dwg. RD722).
4. Curb ramp slopes shown are relative to the true level horizon (zero bubble).
5. Return curb may be provided in lieu of flared slope only if protected from traverse travel by landscaping, see Std. Dwg. RD721. Return curb shall not reduce width of approaching sidewalk.
6. When 2 curb ramps are immediately adjacent, the curb exposure (E) between the adjacent side flares may range between 3" and full design exposure.
7. Curb and gutter is required at curb ramps.
8. Grade breaks at the top and bottom of curb ramp runs shall be perpendicular to the direction of the ramp run. Grade breaks shall not be permitted on the surface of ramp runs and turning spaces. Surface slopes that meet at grade breaks shall be flush.

LEGEND:

- Marked or intended crossing location
- Sidewalk
- Detectable warning surface
- Level area (Turning space/landing)
Unobstructed 4.5' x 4.5'
With obstruction 4.5' x 5.5' (Longer dimension in direction of pedestrian street crossing).
For the purposes of this application, a max. 2.0% finished surface slope (for drainage) measured perpendicular in two directions is considered level.
- Cross slope 1.5% max.
(Max. 2.0% finished surface slope)
(Normal sidewalk cross slope)
- Running slope 7.5% max.
(Max. 8.3% finished surface slope)
- Flare slope
(Max. 10% finished surface slope)
- Curb height
- 4' x 4' clear space
- Pedestrian Access Route

CALC. BOOK NO. N/A SDR DATE 19-JUL-2021

NOTE: All material and workmanship shall be in accordance with the current City of The Dalles Standard Specifications

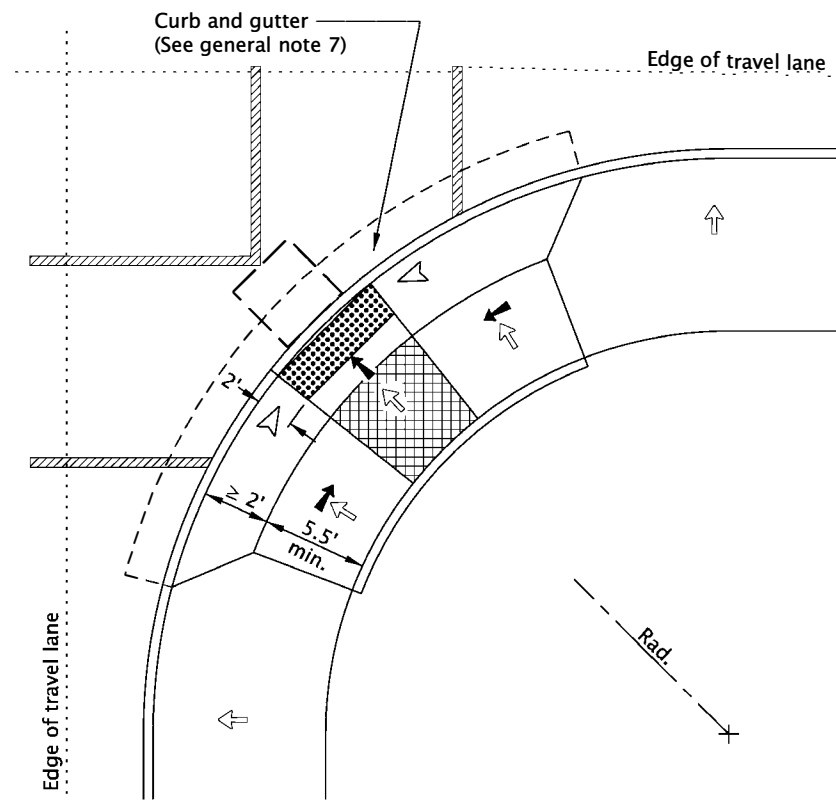
CITY OF THE DALLES STANDARD DRAWINGS

COMBINATION CURB RAMP

2025

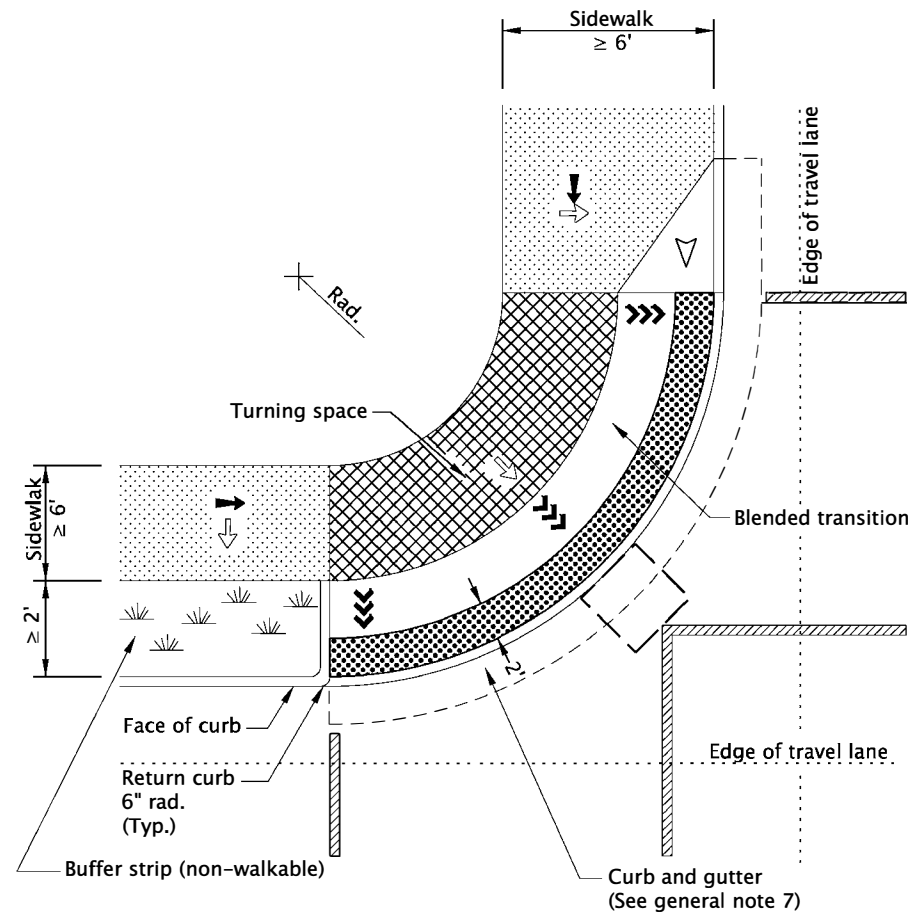
DATE	REVISION	DESCRIPTION
07-2021	DRAWING CREATED	

The selection and use of this Standard Drawing, while designed in accordance with generally accepted engineering principles and practices, is the sole responsibility of the user and should not be used without consulting a Registered Professional Engineer.



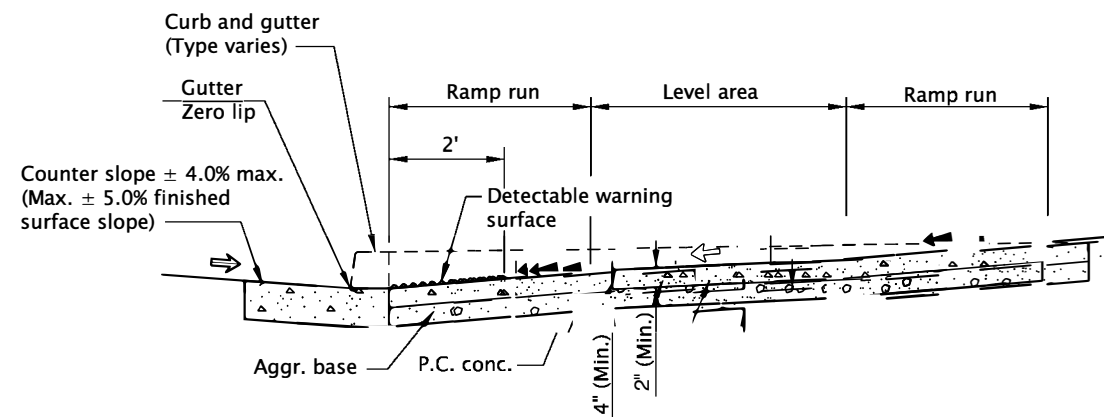
**DIAGONAL COMBINATION CURB RAMP
OPTION "CC-10"**

(Use only when site constraints prohibit installing two curb ramps)



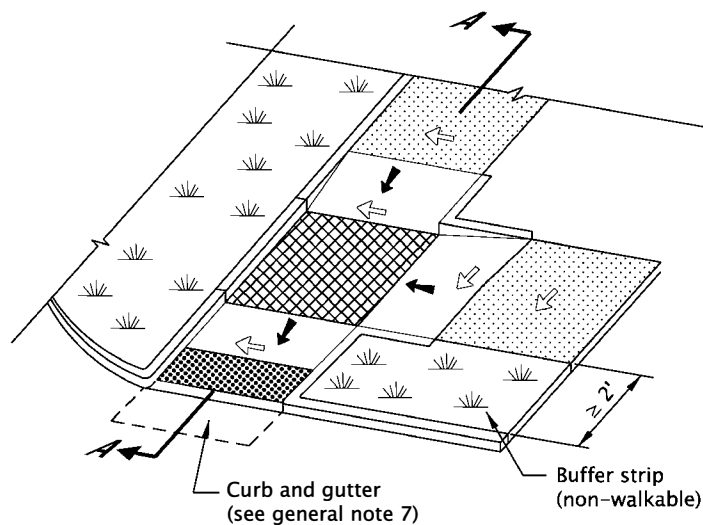
**BLENDED TRANSITION COMBINATION CURB RAMP
OPTION "CC-11"**

(Use only when site constraints prohibit installing two curb ramps)



SECTION A-A

**DIRECTIONAL COMBINATION CURB RAMP
OPTION "CC-12"**



GENERAL NOTES FOR ALL DETAILS ON THIS SHEET:

- 1 Curb ramp details are based on applicable COTD Standards.
- 2 See project plans for details not shown. See Std. Dwgs. RD700 & RD701 for curbs. See Std. Dwgs. RD720 & RD721 for sidewalks. See Std. Dwgs. RD902 through RD908 for detectable warning surface installation details. See Std. Dwg. RD930 for combination curb ramp details.
- 3 Tooled dummy joints are required at all curb ramp slope break lines, (see Std. Dwg. RD722).
- 4 Curb ramp slopes shown are relative to the true level horizon (zero bubble).
- 5 Return curb may be provided in lieu of flared slope only if protected from traverse travel by landscaping, (see Std. Dwg. RD721). Return curb shall not reduce width of approaching sidewalk.
- 6 Only use curb ramp options approved by the City.
- 7 Curb and gutter is required at curb ramps.
- 8 Grade breaks at the top and bottom of curb ramp runs shall be perpendicular to the direction of the ramp run. Grade breaks shall not be permitted on the surface of ramp runs and turning spaces. Surface slopes that meet at grade breaks shall be flush.

LEGEND:

- Marked or intended crossing location
- Sidewalk
- Detectable warning surface
- Level area (Turning space/landing)
Unobstructed 4.5' x 4.5'
With obstruction 4.5' x 5.5' (Longer dimension in direction of pedestrian street crossing).
For the purposes of this application, a max. 2.0% finished surface slope (for drainage) measured perpendicular in two directions is considered level.
- Cross slope 1.5% max.
(Max. 2.0% finished surface slope)
(Normal sidewalk cross slope)
- Running slope 7.5% max.
(Max. 8.3% finished surface slope)
- Running slope 4.0% max.
(Max. 4.9% finished surface slope)
- Flare slope
(Max. 10% finished surface slope)
- 4'x4' clear space

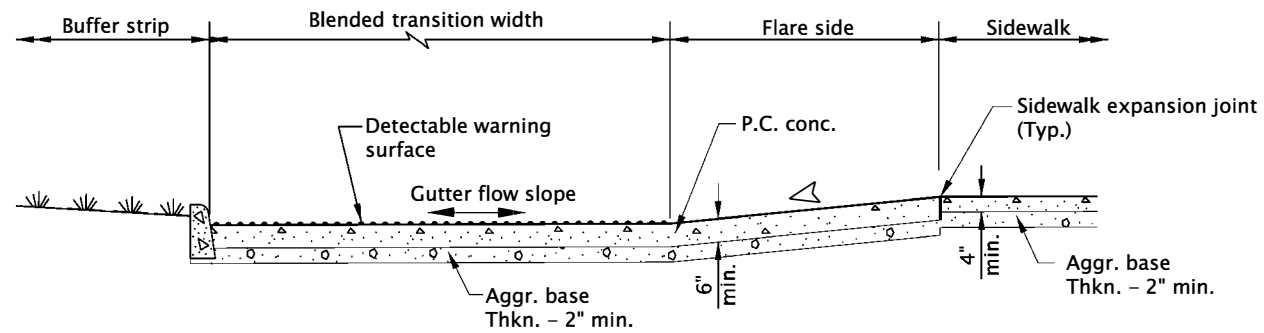
CALC. BOOK NO.	N/A	SDR DATE	19-JUL-2021
----------------	-----	----------	-------------

NOTE: All material and workmanship shall be in accordance with the current City of The Dalles Standard Specifications

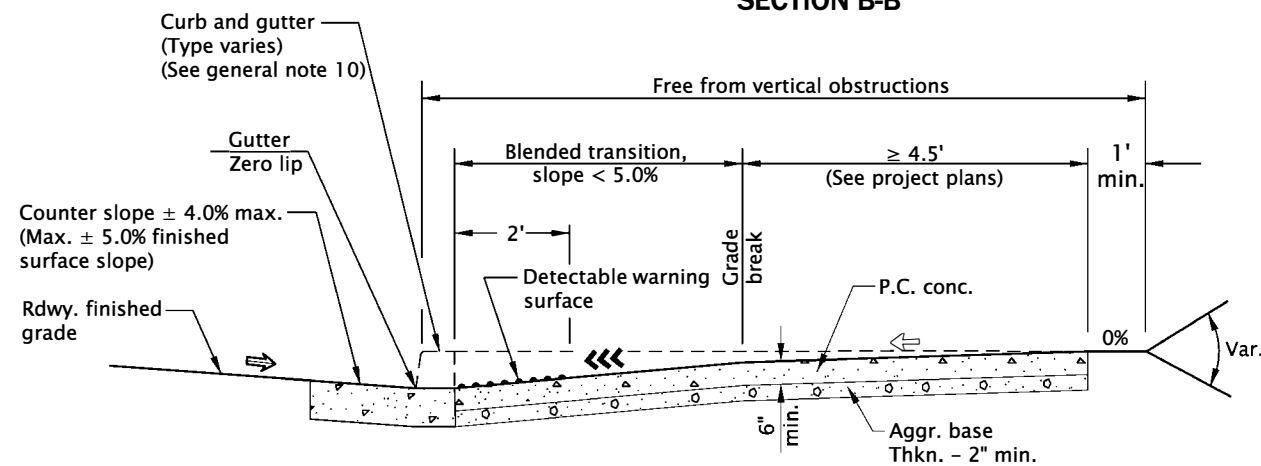
CITY OF THE DALLES STANDARD DRAWINGS	
COMBINATION CURB RAMP SINGLE RAMP	
2025	
DATE	REVISION DESCRIPTION
07-2020	DRAWING CREATED
01-2021	REVISED DETAIL & NOTES
07-2021	REVISED DETAIL & NOTES

The selection and use of this Standard Drawing, while designed in accordance with generally accepted engineering principles and practices, is the sole responsibility of the user and should not be used without consulting a Registered Professional Engineer.

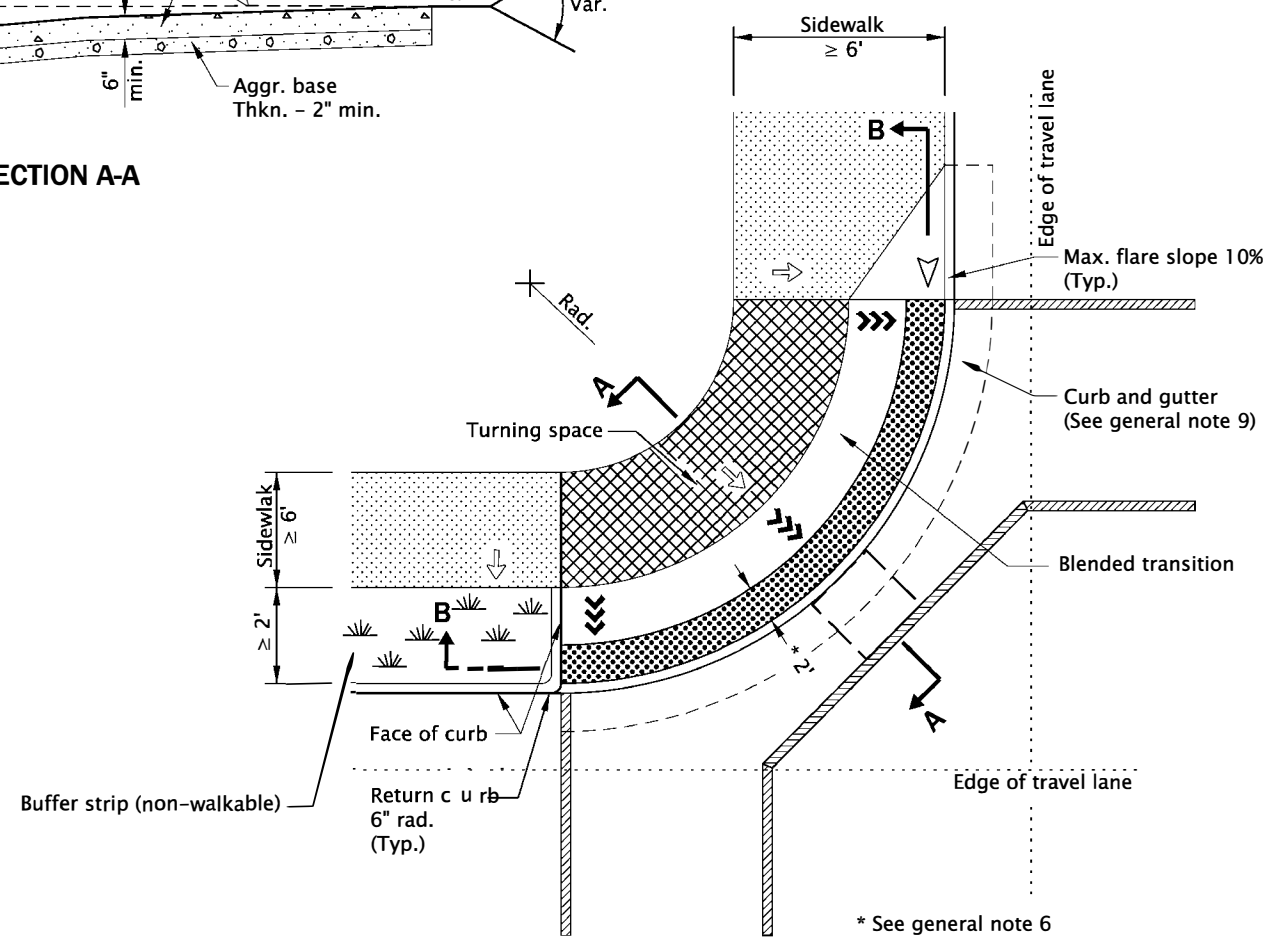
rd940.dgn 19-JUL-2021



SECTION B-B



SECTION A-A



DIAGONAL BLENDED TRANSITION CURB RAMP

* See general note 6

GENERAL NOTES FOR ALL DETAILS ON THIS SHEET:

1. Curb ramp details are based on applicable COTD Standards.
2. See project plans for details not shown. See Std. Dwgs. RD700 & RD701 for curbs. See Std. Dwgs. RD720 & RD721 for sidewalks. See Std. Dwgs. RD902 through RD908 for detectable warning surface installation details.
3. Site conditions normally require a project specific design. See project plans for details not shown.
4. Tooled dummy joints are required at all curb ramp slope break lines, (see Std. Dwg. RD722).
5. Curb ramp slopes shown are relative to the true level horizon (zero bubble).
6. Place detectable warning surface at the back of curb for a minimum depth of 2' in the direction of pedestrian travel full width of curb ramp opening that is adjacent to traffic.
7. Grade breaks shall not be permitted on the surface of ramp runs and turning spaces. Surface slopes that meet at grade breaks shall be flush.
8. Return curb may be provided in lieu of flared slope only if protected from traverse by landscaping. Return curb shall not reduce width of approaching sidewalk.
9. Curb ramps for shared use paths intersecting a roadway shall be full width of path, excluding flares. When a curb ramp is used to provide bicycle access from a roadway to a sidewalk, the curb ramp opening will be ≥ 8' wide.
10. Place an inlet at upstream side of curb ramp or perform other approved design mitigation. Check the gutter flow depth at curb ramp locations to assure that the design flood does not overtop the back of sidewalk.
11. Curb and gutter is required at curb ramps.
12. Only use curb ramp options approved by the City.

LEGEND:

- Marked or intended crossing location
- Sidewalk
- Detectable warning surface
- Level area (Turning space/landing)
Unobstructed 4.5' x 4.5'
With obstruction 4.5' x 5.5' (Longer dimension in direction of pedestrian street crossing).
For the purposes of this application, a max. 2.0% finished surface slope (for drainage) measured perpendicular in two directions is considered level.
- Cross slope 1.5% max.
(Max. 2.0% finished surface slope)
(Normal sidewalk cross slope)
- Counter slope 4.0% max. ascending or descending
(Max. 5.0% finished surface slope)
Slope as required for drainage
- Running slope 4.0% max.
(Max. 4.9% finished surface slope)
- Flare slope
(Max. 10% finished surface slope)
- 4'x4' clear space

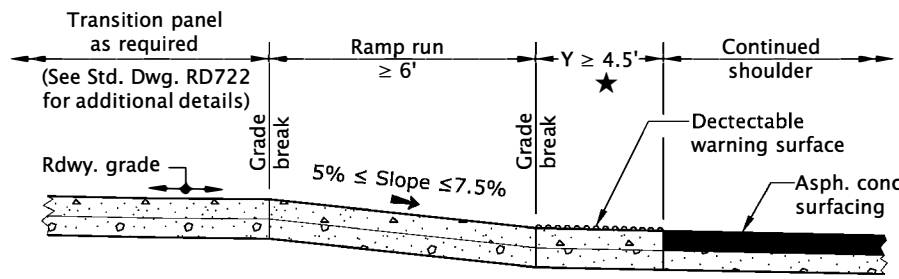
CALC. BOOK NO.	N/A	SDR DATE	19-JUL-2021
----------------	-----	----------	-------------

NOTE: All material and workmanship shall be in accordance with the current City of The Dalles Standard Specifications

CITY OF THE DALLES STANDARD DRAWINGS	
BLENDED TRANSITION CURB RAMP SINGLE RAMP	
2025	
DATE	REVISION DESCRIPTION
07-2020	DRAWING CREATED
07-2021	REVISED NOTES

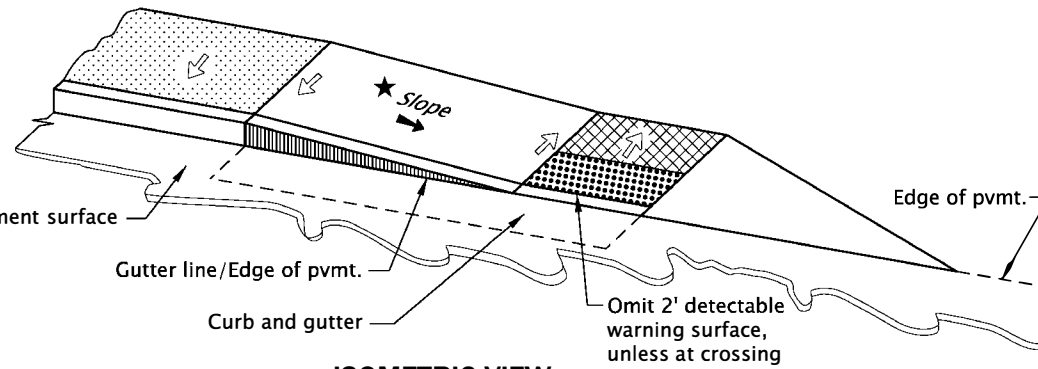
The selection and use of this Standard Drawing, while designed in accordance with generally accepted engineering principles and practices, is the sole responsibility of the user and should not be used without consulting a Registered Professional Engineer.

rd950.dgn 20-JUL-2020

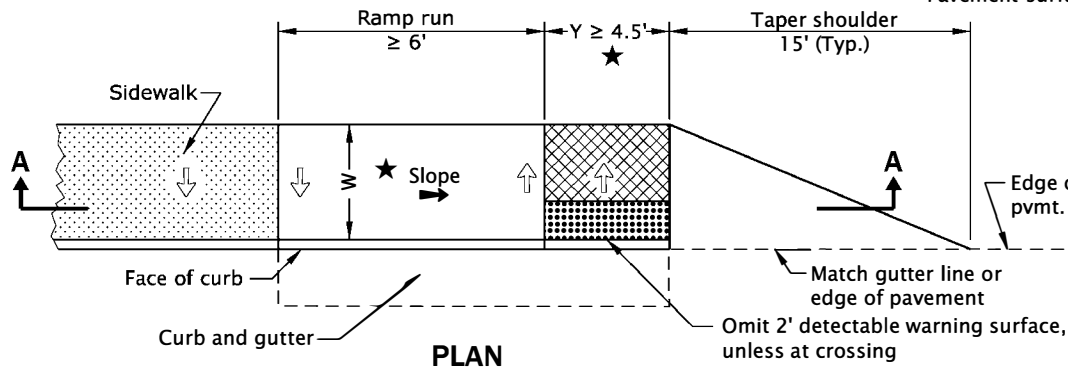


SECTION A-A

★ See general note 12



ISOMETRIC VIEW



PLAN

TAPER OPTION "EW-1"

GENERAL NOTES FOR ALL DETAILS ON THIS SHEET:

1. Curb ramp details are based on applicable COTD Standards.
2. See project plans for details not shown. See Std. Dwgs. RD700 & RD701 for curbs. See Std. Dwgs. RD720 & RD721 for sidewalks. See Std. Dwg. RD722 for transition panel details. See Std. Dwgs. RD902 through RD908 for detectable warning surface installation details.
3. Site conditions normally require a project special design. See project plans for details not shown.
4. Tooled dummy joints are required at all curb ramp grade break lines, (see Std. Dwg. RD722).
5. Curb ramp slopes shown are relative to the true level horizon (zero bubble).
6. Place detectable warning surface at the back of curb for a minimum depth of 2' at curb ramp that is adjacent to traffic.
7. Place an inlet at upstream side of curb ramp or perform other approved design mitigation. Check the gutter flow depth at curb ramp locations to assure that the design flood does not overtop the back of sidewalk.
8. When a shared use path terminates, the curb ramp shall be the full width of the path, the turning space Y-dimension should be minimum 8' wide to enable bicycles to ride from ramp to shoulder.
9. Grade breaks at the top and bottom of curb ramp runs shall be perpendicular to the direction of the ramp run. Grade breaks shall not be permitted on the surface of ramp runs and turning spaces. Surface slopes that meet at grade breaks shall be flush.
10. Curb and gutter is required at curb ramps.
11. All end of sidewalk options can be used for curved or tangent roadway sections. Superrelated roadways require site specific details.
12. When the slope of the ramp run is greater than 5.0%, a min. landing space of 4.5' x 4.5' with a 1.5% max. slope (2.0% finished surface) is required at the bottom of the curb ramp. See section A-A & section B-B.

LEGEND:

- Sidewalk
- Transition panel
- Detectable warning surface
- Level area (Turning space/landing)
Unobstructed 4.5' x 4.5'
With obstruction 4.5' x 5.5' (Longer dimension in direction of pedestrian street crossing).
For the purposes of this application, a max. 2.0% finished surface slope (for drainage) measured perpendicular in two directions is considered level.
- Cross slope 1.5% max.
(Max. 2.0% finished surface slope)
(Normal sidewalk cross slope)
- Running slope 7.5% max.
(Max. 8.3% finished surface slope)
- W New construction sidewalk width.
See contract plans for dimension.

CALC. BOOK NO. N/A SDR DATE 20-JULY-2020

NOTE: All material and workmanship shall be in accordance with the current City of The Dalles Standard Specifications

CITY OF THE DALLES STANDARD DRAWINGS

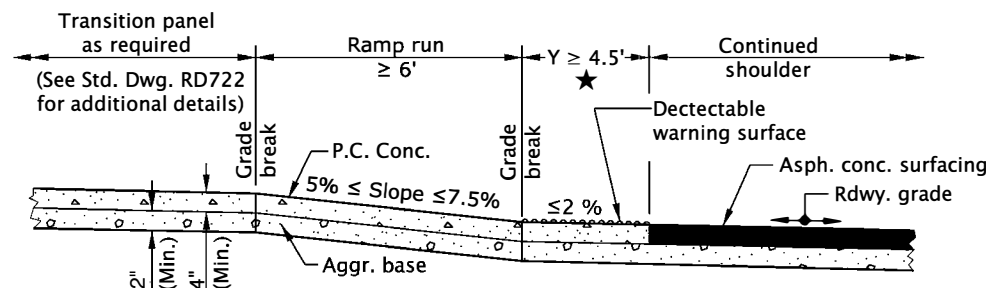
END OF WALK CURB RAMP

2025

DATE	REVISION	DESCRIPTION
07-2020	DRAWING CREATED	

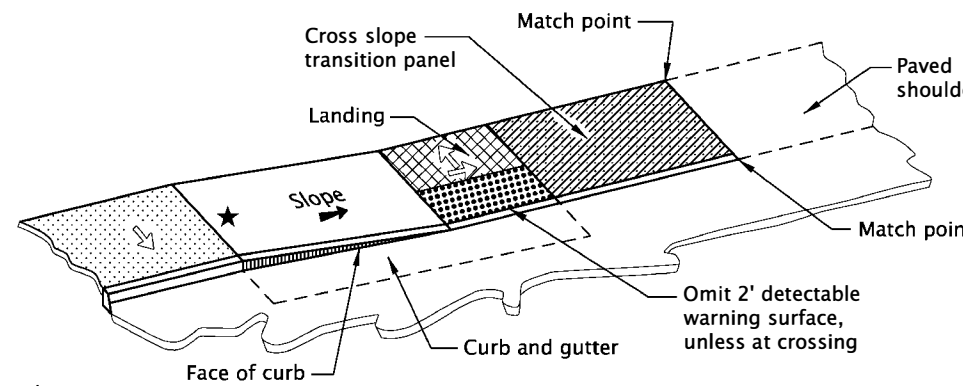
The selection and use of this Standard Drawing, while designed in accordance with generally accepted engineering principles and practices, is the sole responsibility of the user and should not be used without consulting a Registered Professional Engineer.

RD950

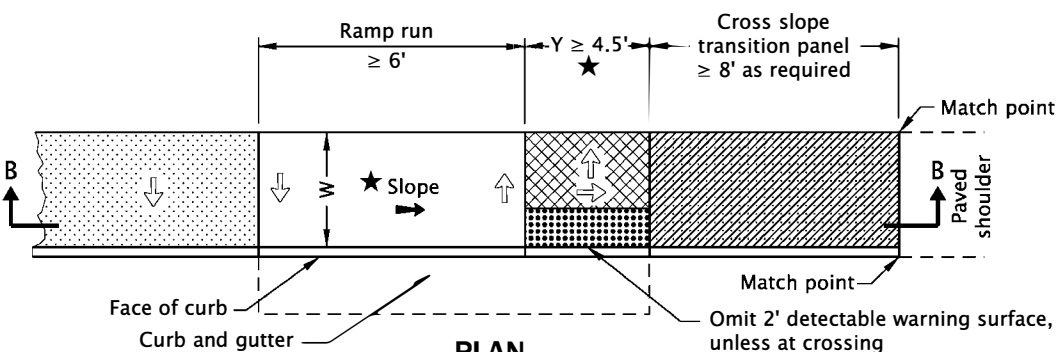


SECTION B-B

★ See general note 12



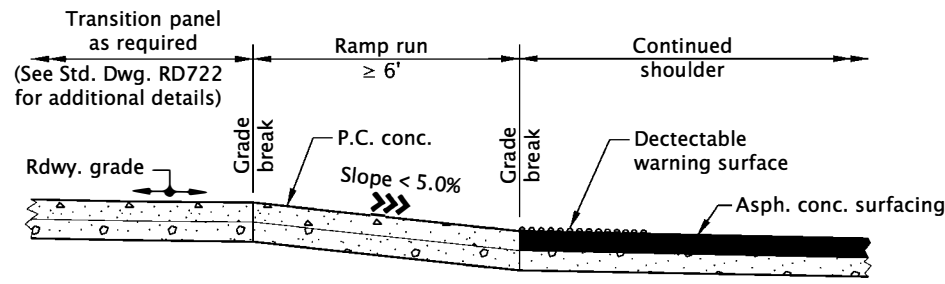
ISOMETRIC VIEW



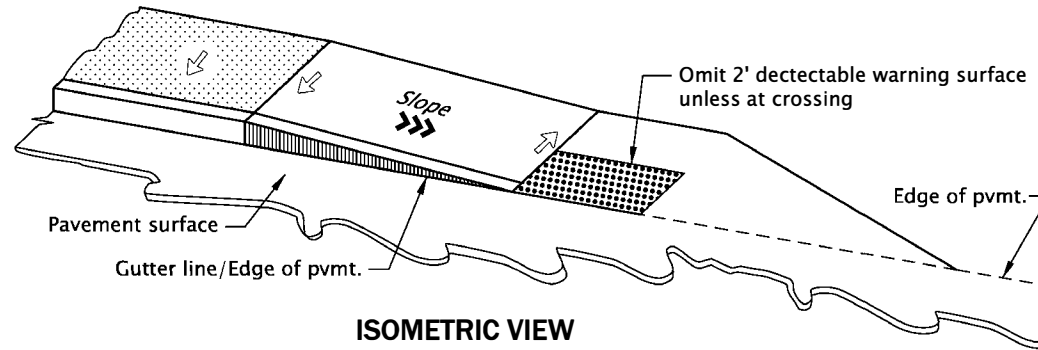
PLAN
(Curb ramp > 5.0% shown)

SHOULDER OPTION "EW-2"

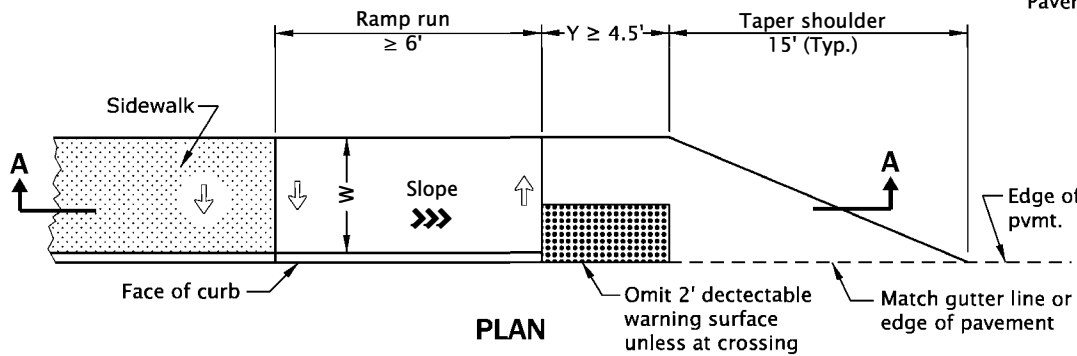
rd952.dgn 19-JUL-2021



SECTION A-A

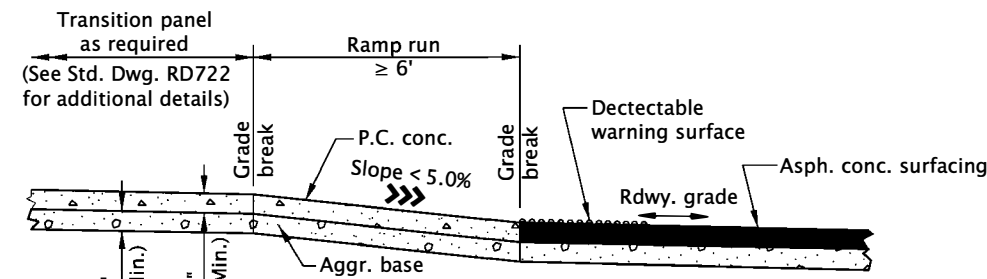


ISOMETRIC VIEW

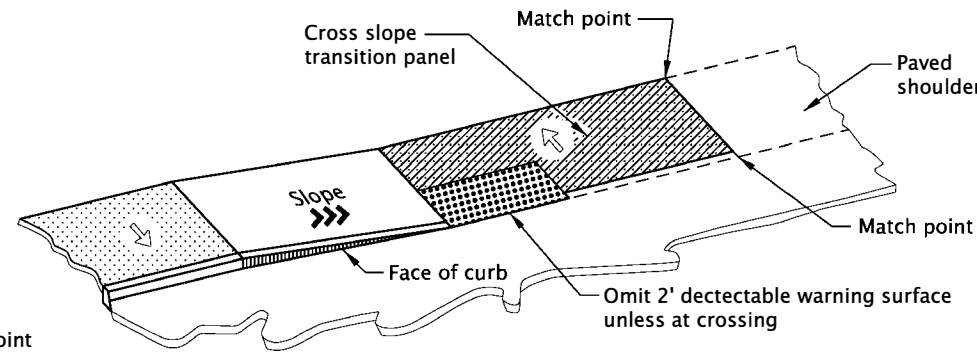


PLAN

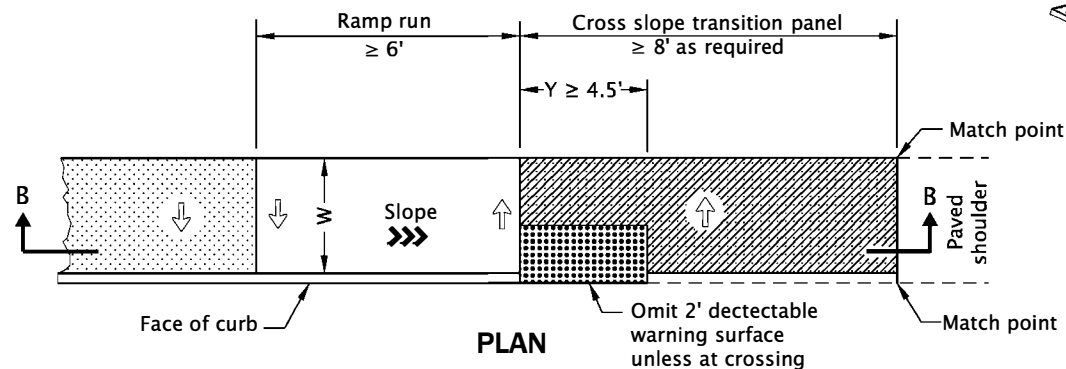
**BLENDED TRANSITION
TAPER OPTION "EW-3"**



SECTION B-B



ISOMETRIC VIEW



PLAN

**BLENDED TRANSITION
SHOULDER OPTION "EW-4"**

GENERAL NOTES FOR ALL DETAILS ON THIS SHEET:

1. Curb ramp details are based on applicable COTD Standards.
2. See project plans for details not shown.
See Std. Dwgs. RD700 & RD701 for curbs.
See Std. Dwgs. RD720 & RD721 for sidewalks.
See Std. Dwg. RD722 for transition panel details.
See Std. Dwgs. RD902 through RD908 for detectable warning surface installation details.
3. Site conditions normally require a project special design. See project plans for details not shown.
4. Tooled dummy joints are required at all curb ramp grade break lines, (see Std. Dwg. RD722).
5. Curb ramp slopes shown are relative to the true level horizon (zero bubble).
6. Place detectable warning surface at the back of curb for a minimum depth of 2' at curb ramp that is adjacent to traffic. When there is no curb, the detectable warning surface shall be placed at the edge of roadway.
7. Place an inlet at upstream side of curb ramp or perform other approved design mitigation. Check the gutter flow depth at curb ramp locations to assure that the design flood does not overtop the back of sidewalk.
8. When a shared use path terminates, the curb ramp shall be the full width of the path, the turning space Y-dimension should be minimum 8' wide to enable bicycles to ride from ramp to shoulder.
9. Grade breaks at the top and bottom of curb ramp runs shall be perpendicular to the direction of the ramp run. Grade breaks shall not be permitted on the surface of ramp runs and turning spaces. Surface slopes that meet at grade breaks shall be flush.
10. All end of sidewalk options can be used for curved or tangent roadway sections. Superrelated roadways require site specific details.

LEGEND:

- Sidewalk
- Transition panel
- Detectable warning surface
- Cross slope 1.5% max.
(Max. 2.0% finished surface slope)
(Normal sidewalk cross slope)
- Running slope 4.0% max.
(Max. 4.9% finished surface slope)
- W New construction sidewalk width.
See contract plans for dimension.

CALC. BOOK NO. N/A

SDR DATE 19-JUL-2021

The selection and use of this Standard Drawing, while designed in accordance with generally accepted engineering principles and practices, is the sole responsibility of the user and should not be used without consulting a Registered Professional Engineer.

NOTE: All material and workmanship shall be in accordance with the current City of the Dalles Standard Specifications

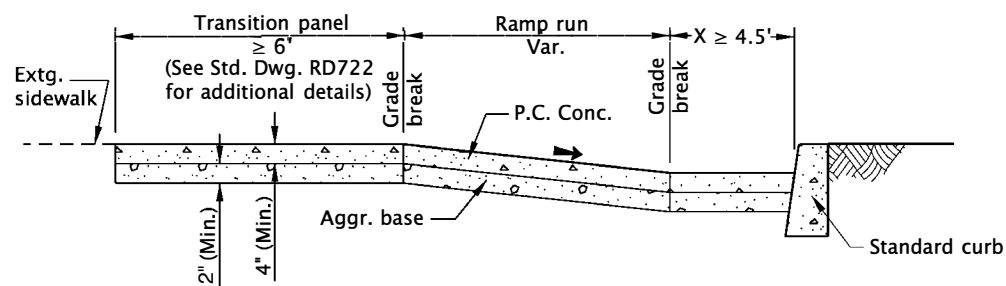
CITY OF THE DALLES STANDARD DRAWINGS

END OF WALK CURB RAMP

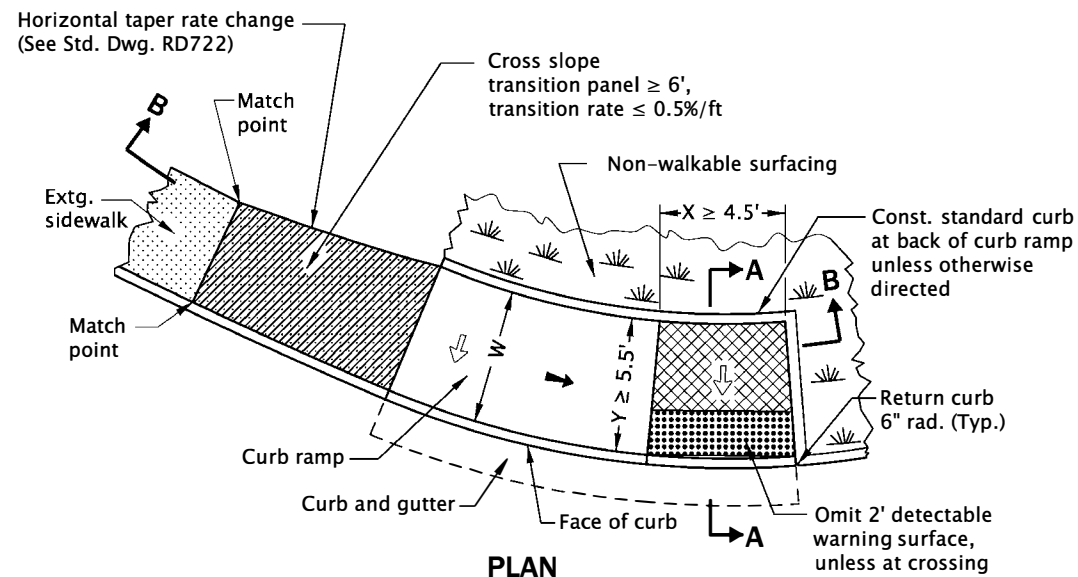
2025

DATE	REVISION	DESCRIPTION
07-2020	DRAWING CREATED	
07-2021	REVISED NOTES	

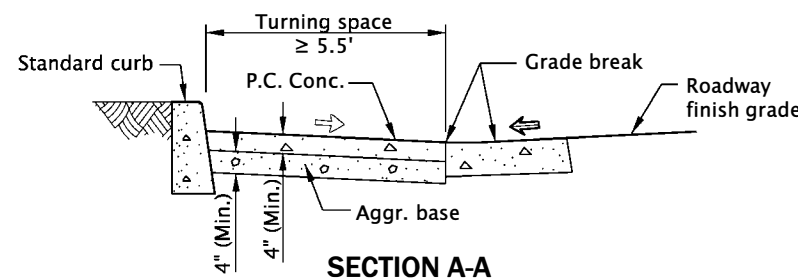
rd960.dgn 19-JUL-2021



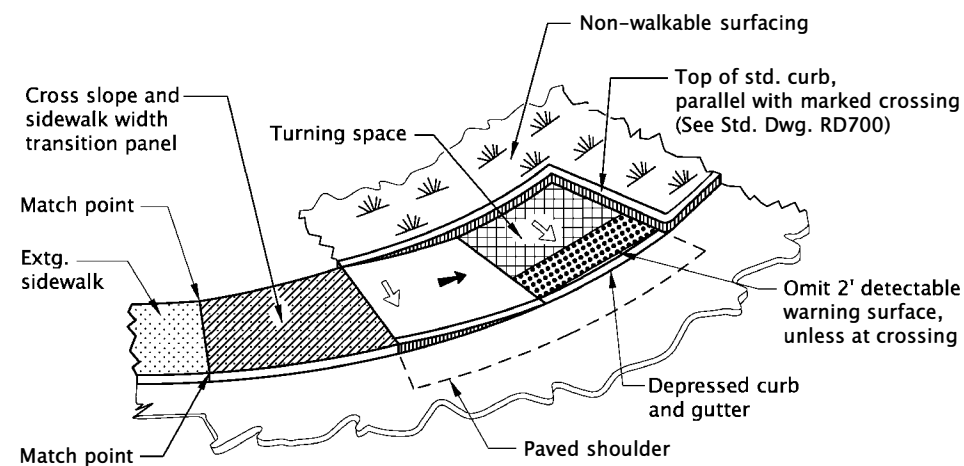
SECTION B-B



PLAN



SECTION A-A



ISOMETRIC VIEW

CURBED OPTION

GENERAL NOTES FOR ALL DETAILS ON THIS SHEET:

1. Curb ramp details are based on applicable COTD applicable Standards.
2. See project plans for details not shown.
See Std. Dwgs. RD700 & RD701 for curbs.
See Std. Dwgs. RD720 & RD721 for sidewalks.
See Std. Dwg. RD722 for transition panel details.
See Std. Dwgs. RD902 through RD908 for detectable warning surface installation details.
See Std. Dwg. RD920 for parallel curb ramp details.
3. Site conditions normally require a project special design. See project plans for details not shown.
4. Tooled dummy joints are required at all curb ramp grade break lines, (see Std. Dwg. RD722).
5. Curb ramp slopes shown are relative to the true level horizon (zero bubble).
6. Place detectable warning surface at the back of curb for a minimum depth of 2' in the direction of pedestrian travel full width of curb ramp opening that is adjacent to traffic.
7. Place an inlet at upstream side of curb ramp or perform other approved design mitigation. Check the gutter flow depth at curb ramp locations to assure that the design flood does not overtop the back of sidewalk.
8. When a shared use path terminates, the curb ramp shall be the full width of the path, the turning space Y-dimension should be minimum 8' wide to enable bicycles to ride from ramp to shoulder.
9. Grade breaks at the top and bottom of curb ramp runs shall be perpendicular to the direction of the ramp run. Grade breaks shall not be permitted on the surface of ramp runs and turning spaces. Surface slopes that meet at grade breaks shall be flush.
10. Curb and gutter is required at curb ramps.
11. Unique curb ramp option can be used for curved or tangent roadway sections. Superelevated roadways require a site specific detail.

LEGEND:

- Sidewalk
- Transition panel
- Detectable warning surface
- Level area (Turning space/landing)
Unobstructed 4.5' x 4.5'
With obstruction 4.5' x 5.5' (Longer dimension in direction of pedestrian street crossing).
For the purposes of this application, a max. 2.0% finished surface slope (for drainage) measured perpendicular in two directions is considered level.
- Cross slope 1.5% max.
(Max. 2.0% finished surface slope)
(Normal sidewalk cross slope)
- Running slope 7.5% max.
(Max. 8.3% finished surface slope)
- Counter slope 4.0% max. ascending or descending,
(Max. 5.0% finished surface slope)
Slope as required for drainage
- W New construction sidewalk width. See contract plans for dimension

CALC. BOOK NO. N/A SDR DATE 19-JUL-2021

NOTE: All material and workmanship shall be in accordance with the current City of The Dalles Standard Specifications

CITY OF THE DALLES STANDARD DRAWINGS

UNIQUE CURB RAMP

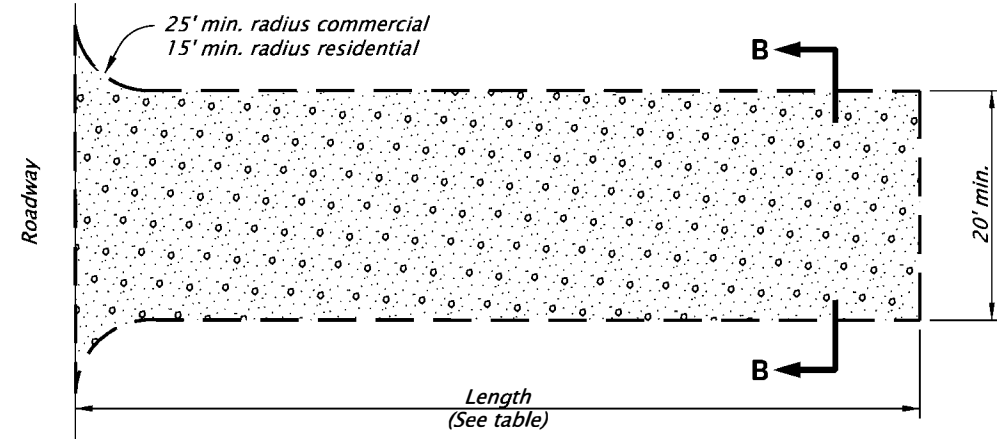
2025

The selection and use of this Standard Drawing, while designed in accordance with generally accepted engineering principles and practices, is the sole responsibility of the user and should not be used without consulting a Registered Professional Engineer.

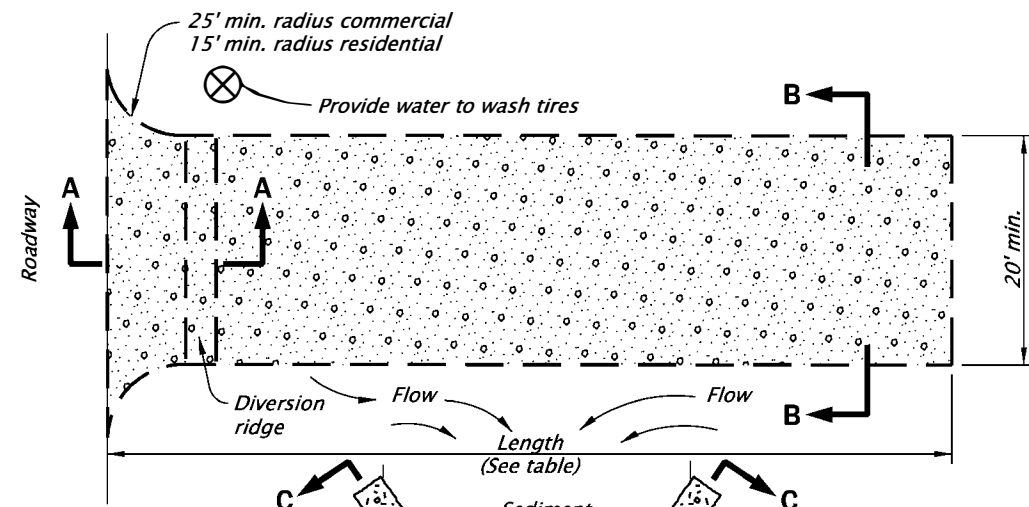
DATE	REVISION	DESCRIPTION
07-2020	DRAWING CREATED	
07-2021	REVISED DETAILS AND NOTES	

rd1000.dgn 01-20-2021

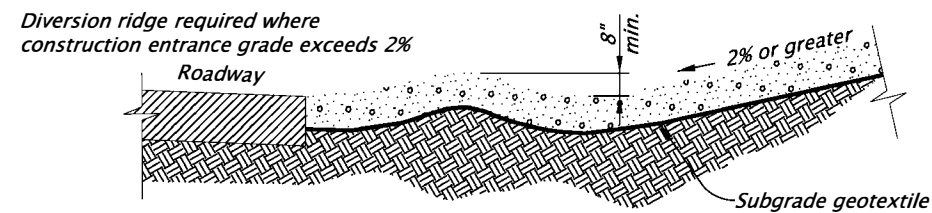
RD1000



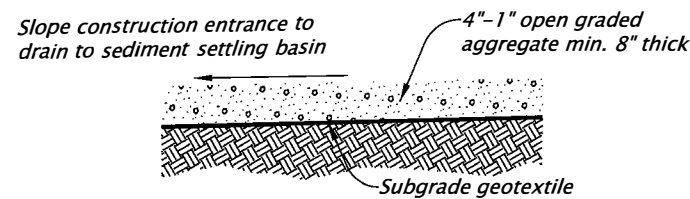
CONSTRUCTION ENTRANCE - TYPE 1
NOT TO SCALE



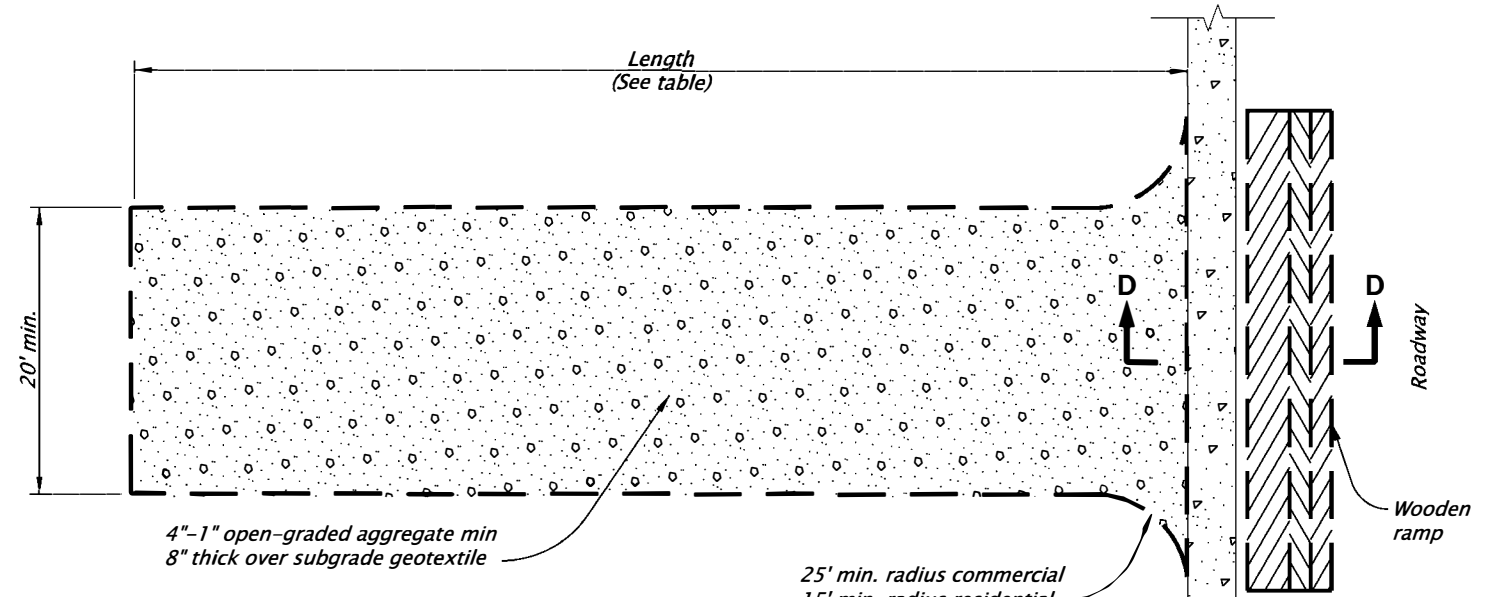
CONSTRUCTION ENTRANCE - TYPE 2
NOT TO SCALE



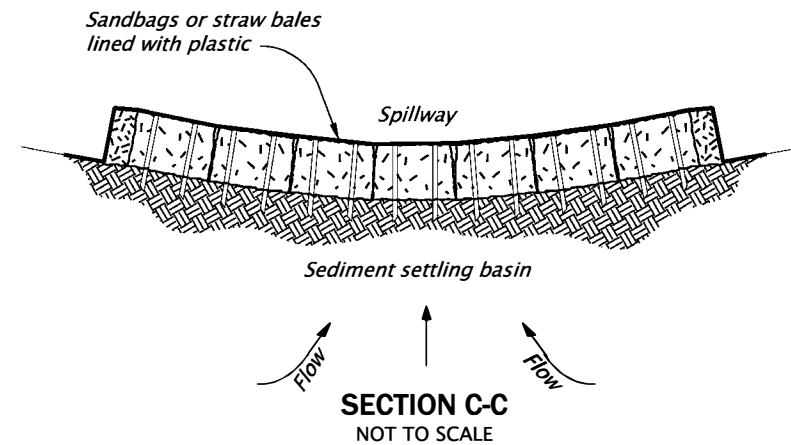
SECTION A-A
NOT TO SCALE



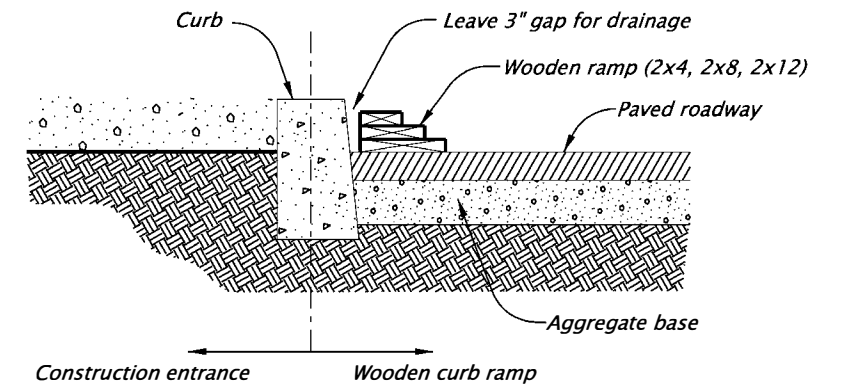
SECTION B-B
NOT TO SCALE



CONSTRUCTION ENTRANCE - TYPE 3
(TYPE 1 OR 2 WITH EXISTING CURB)
NOT TO SCALE



SECTION C-C
NOT TO SCALE



WOODEN CURB RAMP SECTION D-D
NOT TO SCALE

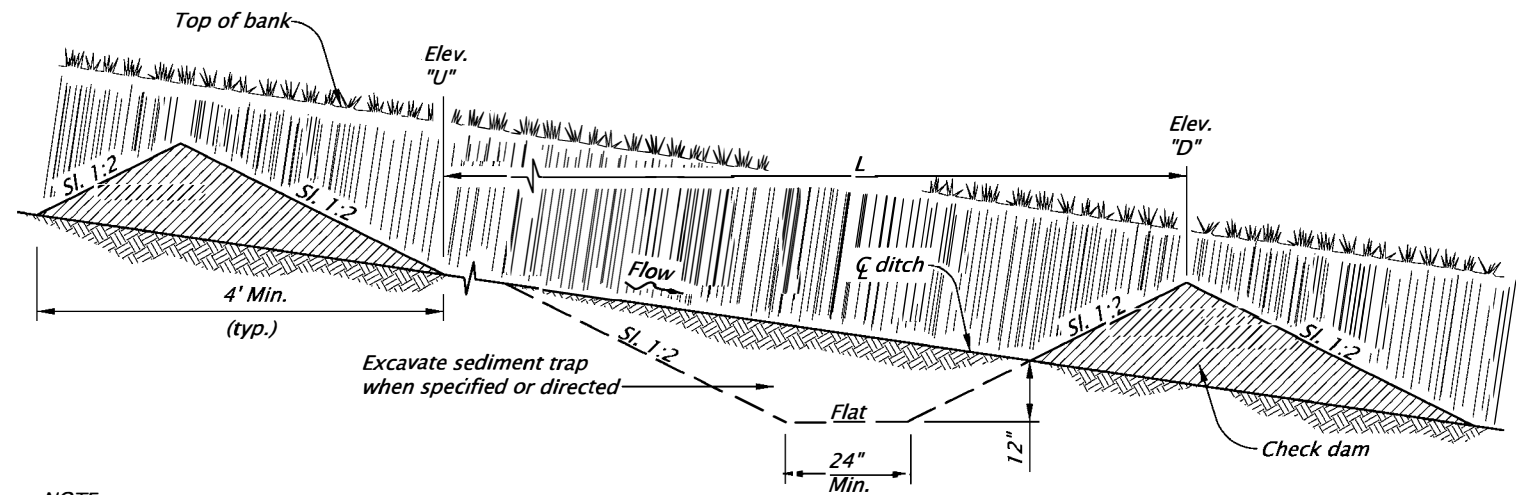
NOTES:

1. The Type 1 entrance is a simple entrance without a diversion ridge or settling basin.
2. The wooden ramp may be used on either Type 1 or Type 2 entrances in situations where there is curb and the curb is not removed for the construction entrance.

CONSTRUCTION ENTRANCE TABLE MINIMUM LENGTH	
Length (FT)	Area Of Exposed Soil (Acre)
20	0.25
50	0.25 < A < 1.0
100	A > 1.0

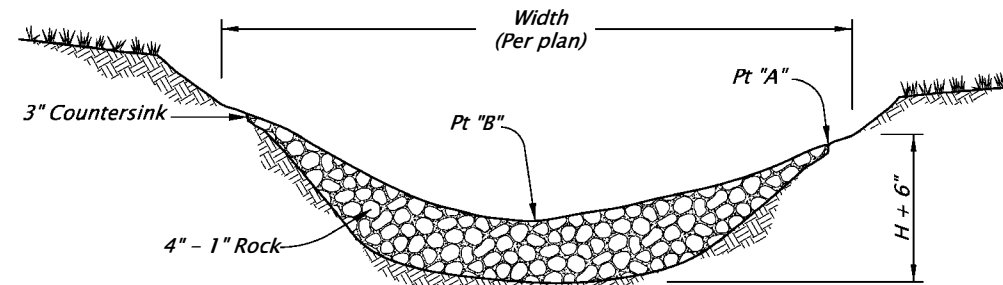
CALC. BOOK NO. <u>N/A</u>	SDR DATE <u>January, 2021</u>
NOTE: All material and workmanship shall be in accordance with the current City of The Dalles Standard Specifications	
CITY OF THE DALLES STANDARD DRAWINGS	
CONSTRUCTION ENTRANCES	
2025	
DATE	REVISION DESCRIPTION
Jan 2021	Removed Calc book numbers

The selection and use of this Standard Drawing, while designed in accordance with generally accepted engineering principles and practices, is the sole responsibility of the user and should not be used without consulting a Registered Professional Engineer.



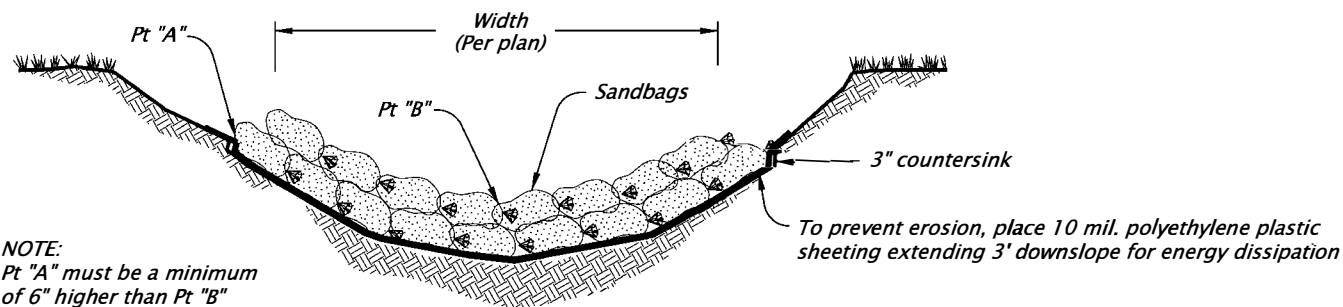
NOTE:
L = Spacing along swale or ditch so that Elevation "U" equals Elevation "D".

TYPICAL PROFILE SECTION CHECK DAMS (SHOWN WITH AGGREGATE)
NOT TO SCALE



NOTE:
Pt "A" must be a minimum of 6" higher than Pt "B"

AGGREGATE CHECK DAM - TYPE 1
NOT TO SCALE



NOTE:
Pt "A" must be a minimum of 6" higher than Pt "B"

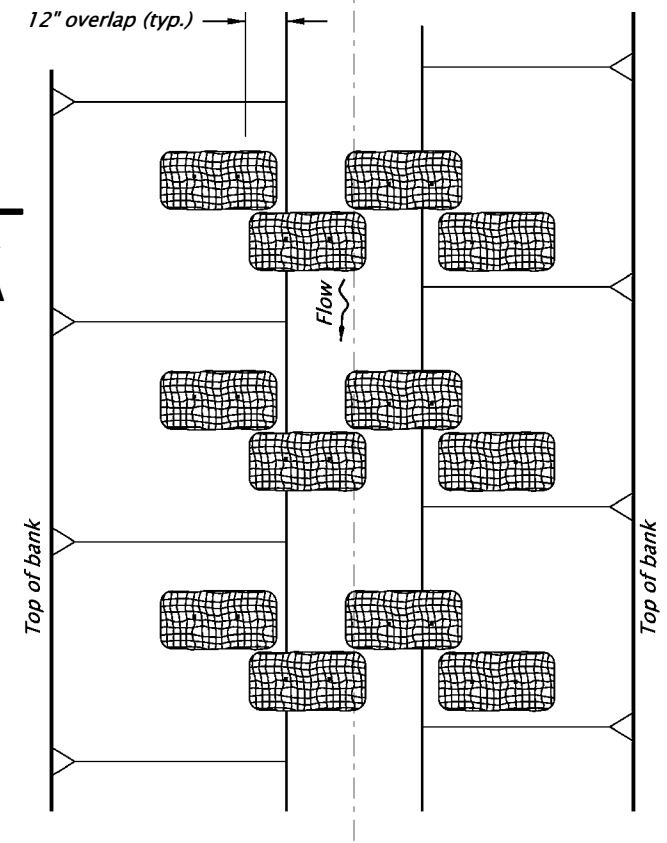
SANDBAG CHECK DAM - TYPE 4
NOT TO SCALE

NOTES:

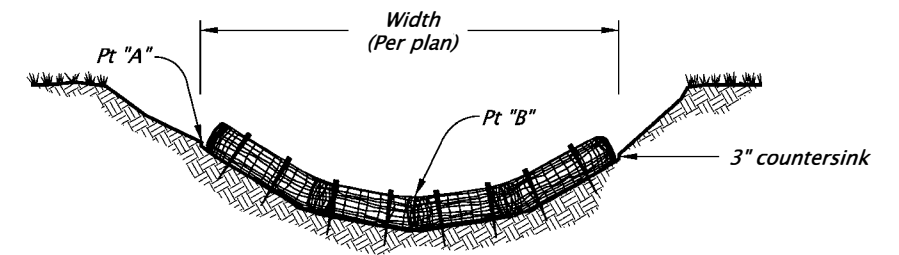
1. Type 3 - stake biofilter bags with two 2"x2"x18" (minimum) wood stakes per bag. Drive stakes a minimum of 6" into the ground and flush with the top of the bags. Omit stakes if placed over paved surfaces. Overlap bags 12" minimum at each joint.
2. Type 4 - Tightly abut or overlap ends of sandbags at each joint.
3. Spacing between check dams for all check dam types shall comply with the typical profile section shown above.
4. Construct check dams Type 3 or 4 with two bags when installed in paved gutter with curb section.

MAXIMUM CHECK DAM SPACING "L"				
Ditch Grade	H=8"	H=12"	H=18"	H=24"
10%	**	**	15'	20'
9%	**	**	16'	22'
8%	**	**	18'	25'
7%	**	**	21'	28'
6%	**	16'	25'	33'
5%	**	20'	30'	40'
4%	16'	25'	37'	50'
3%	22'	33'	50'	66'
2%	33'	50'	75'	100'

** Not allowed H = Min. dam height



PLAN



SECTION A-A

BIOFILTER BAG CHECK DAM - TYPE 3
NOT TO SCALE

The selection and use of this Standard Drawing, while designed in accordance with generally accepted engineering principles and practices, is the sole responsibility of the user and should not be used without first consulting a Registered Professional Engineer.

All materials shall be in accordance with the current City of The Dalles Standard Specifications

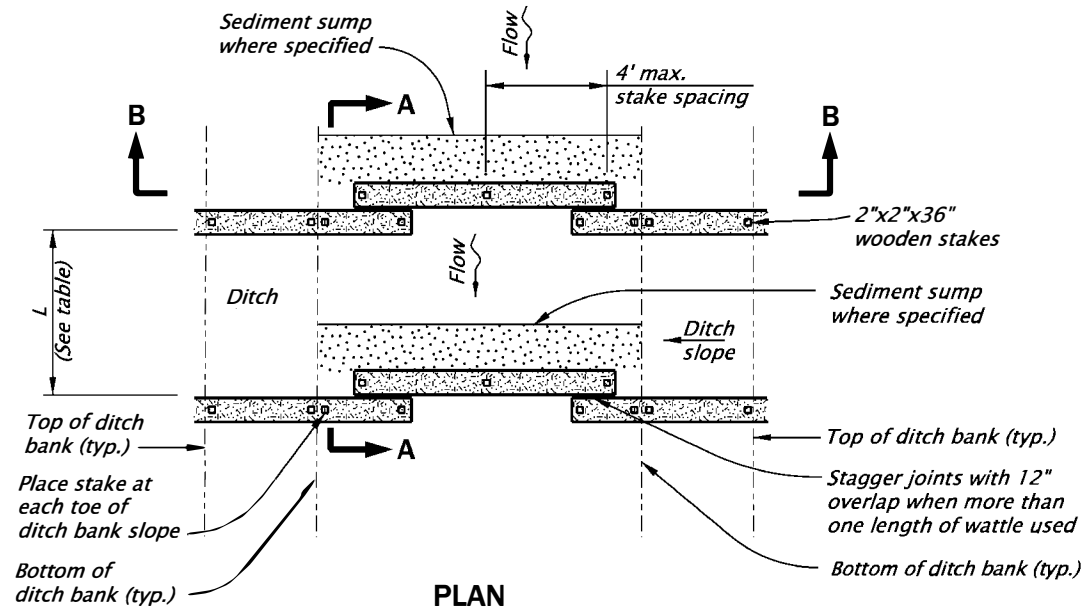
CITY OF THE DALLES STANDARD DRAWINGS

CHECK DAMS TYPE 1, 3 AND 4
2025

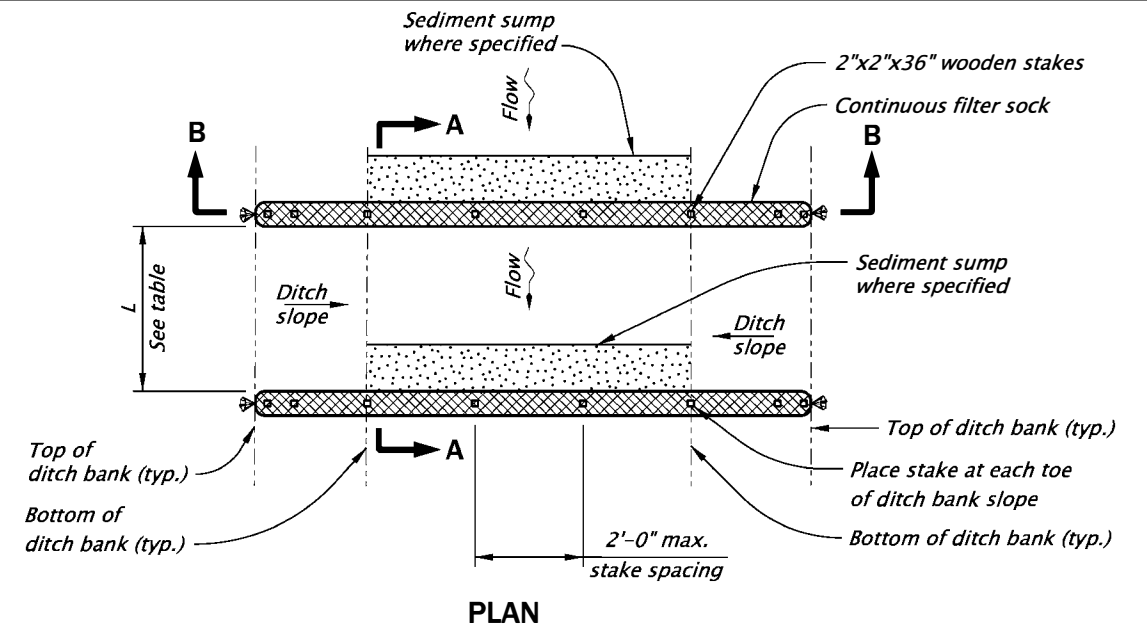
DATE	REVISION DESCRIPTION
01-2021	REMOVED CALC BOOK NUMBERS
07-2024	ADDED NOTE 4

CALC. BOOK NO.	N/A	SDR DATE	12-JUL-2024	RD1005
----------------	-----	----------	-------------	---------------

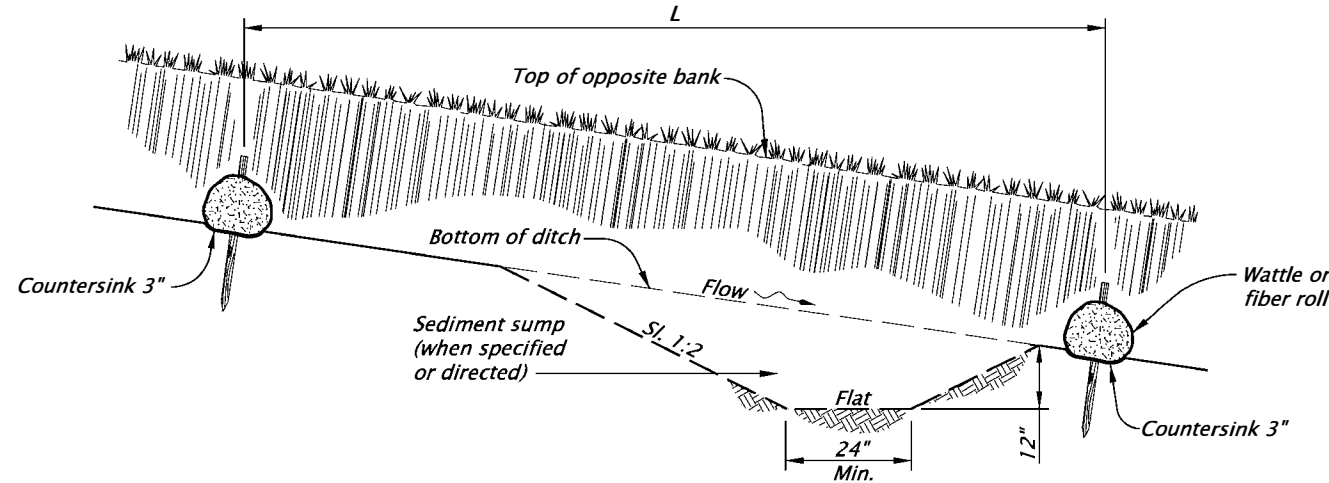
rd1006.dgn 01-20-2021



PLAN

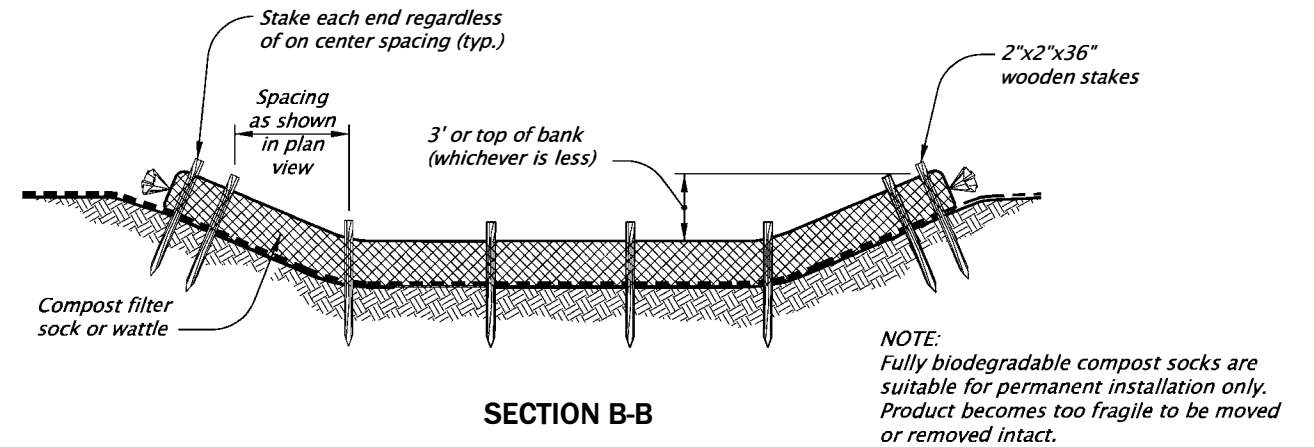


PLAN



SECTION A-A

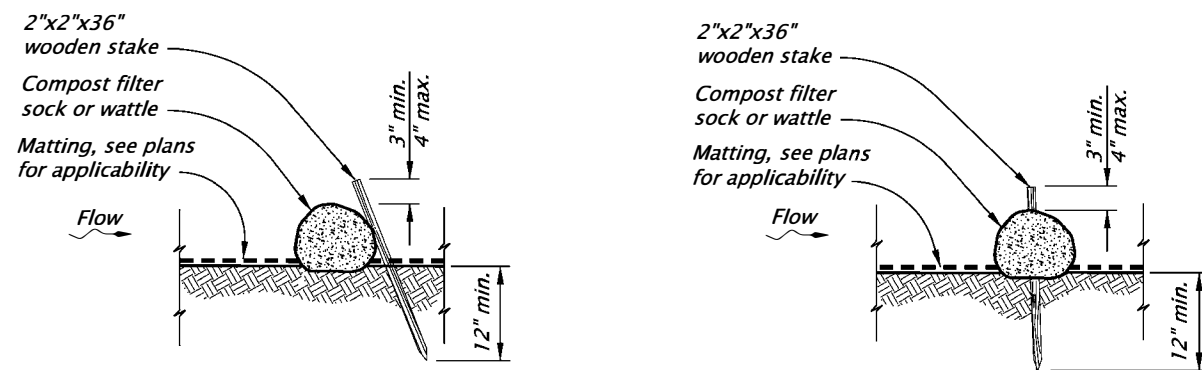
WATTLE / FIBER ROLL CHECK DAM - TYPE 2
NOT TO SCALE



SECTION B-B

COMPOST FILTER SOCK CHECK DAM - TYPE 6
NOT TO SCALE

NOTE:
Fully biodegradable compost socks are suitable for permanent installation only. Product becomes too fragile to be moved or removed intact.



ALTERNATIVE 1

ALTERNATIVE 2

FIBER ROLL AND COMPOST SOCK STAKING ALTERNATIVES
NOT TO SCALE

MAXIMUM CHECK DAM SPACING "L"				
Ditch Grade	H=8"	H=12"	H=18"	H=24"
10%	**	**	15'	20'
9%	**	**	16'	22'
8%	**	**	18'	25'
7%	**	**	21'	28'
6%	**	16'	25'	33'
5%	**	20'	30'	40'
4%	16'	25'	37'	50'
3%	22'	33'	50'	66'
2%	33'	50'	75'	100'

** Not allowed H = Min. dam height

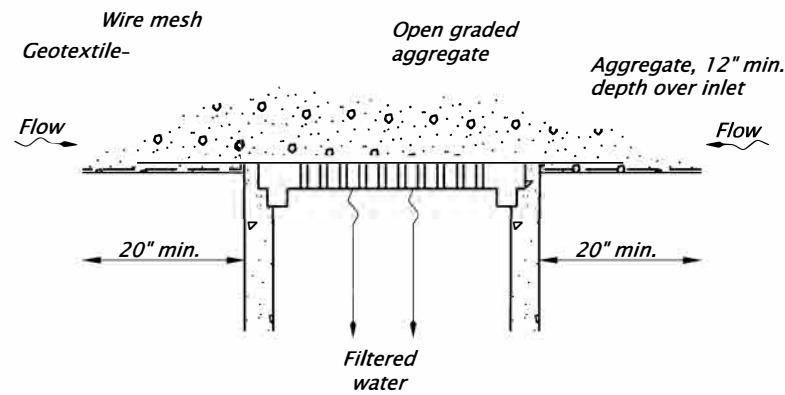
CALC. BOOK NO. N/A	SDR DATE January, 2021
NOTE: All material and workmanship shall be in accordance with the current City of The Dalles Standard Specifications	
CITY OF THE DALLES STANDARD DRAWINGS	
CHECK DAMS TYPE 2 AND 6	
2025	
DATE	REVISION DESCRIPTION
Jan 2021	Removed Calc book numbers

The selection and use of this Standard Drawing, while designed in accordance with generally accepted engineering principles and practices, is the sole responsibility of the user and should not be used without consulting a Registered Professional Engineer.

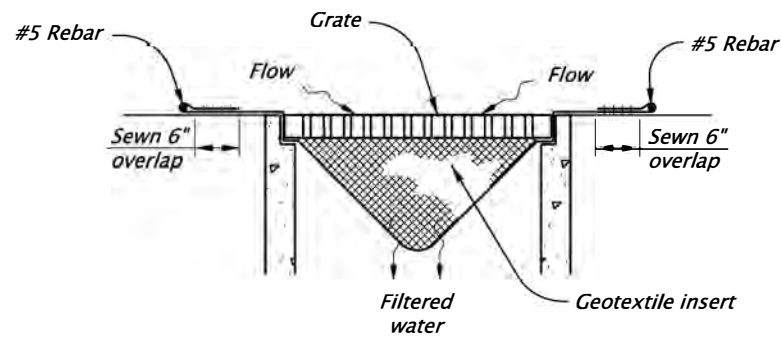
RD1006

rd1010.dgn 01-20-2021

RD1010

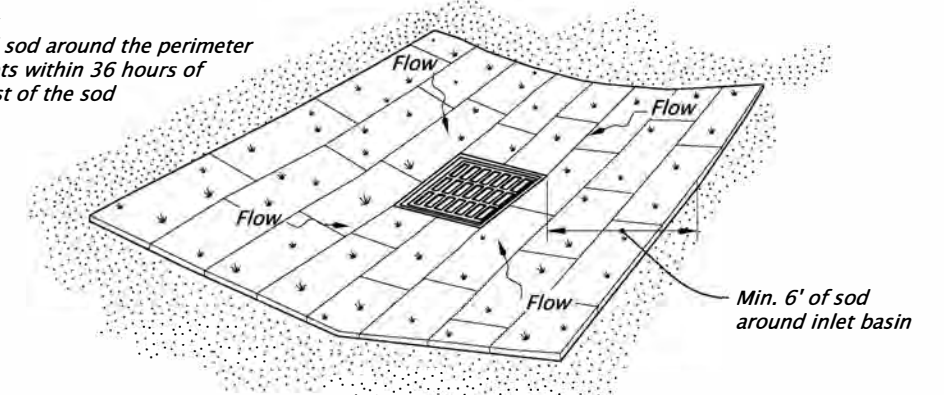


GEOTEXTILE/WIRE MESH/AGGREGATE - TYPE 2
NOT TO SCALE

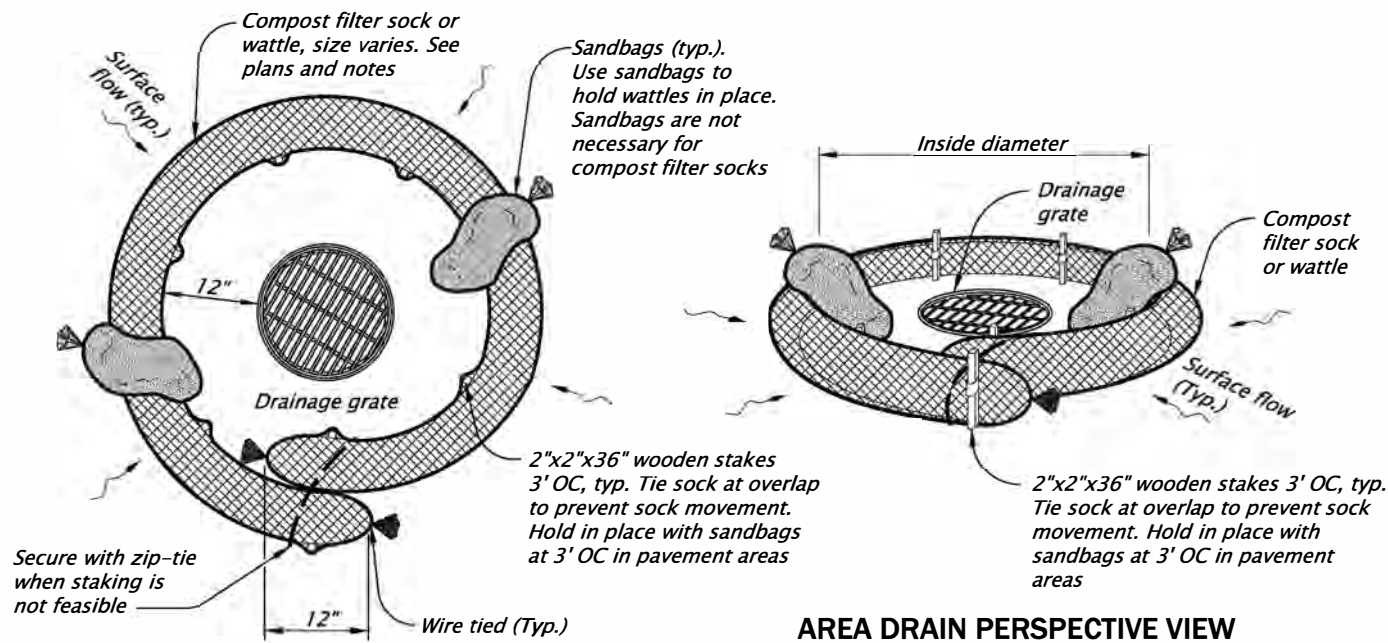


PREFABRICATED FILTER INSERT - TYPE 3
NOT TO SCALE

NOTE:
Install sod around the perimeter
of inlets within 36 hours of
harvest of the sod

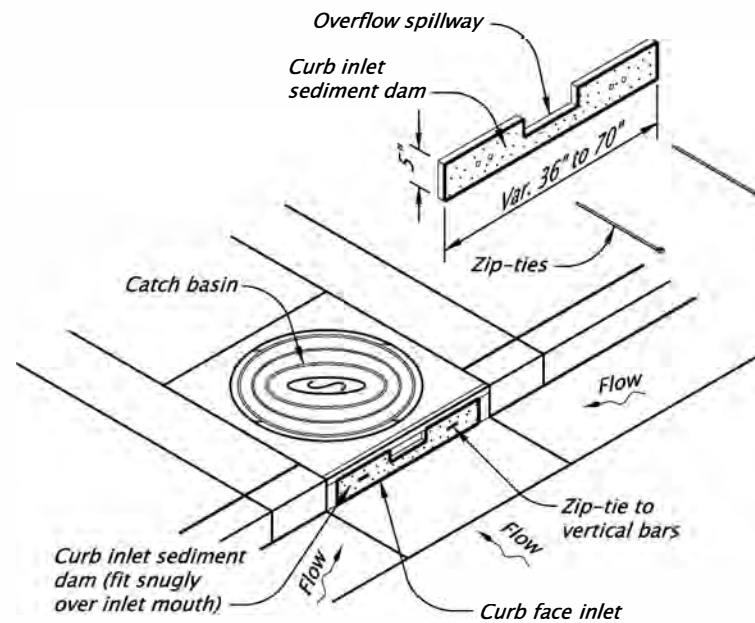


SOD PROTECTION - TYPE 6
NOT TO SCALE

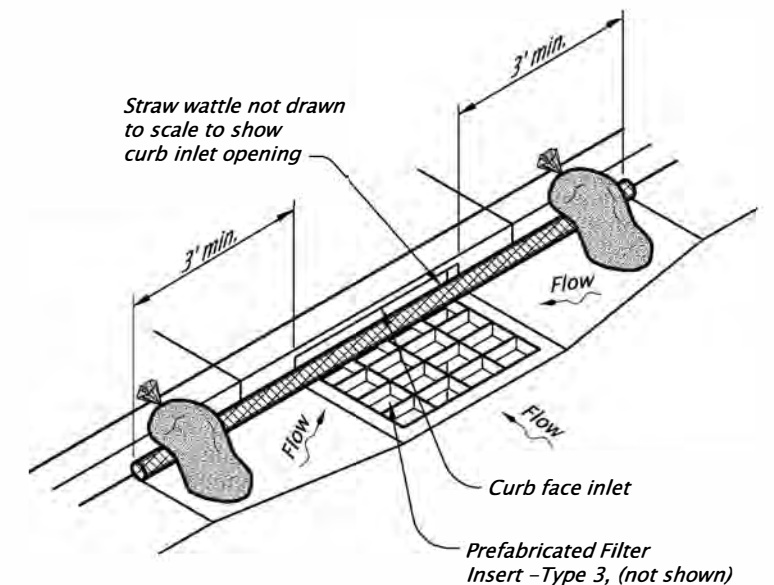


AREA DRAIN PLAN

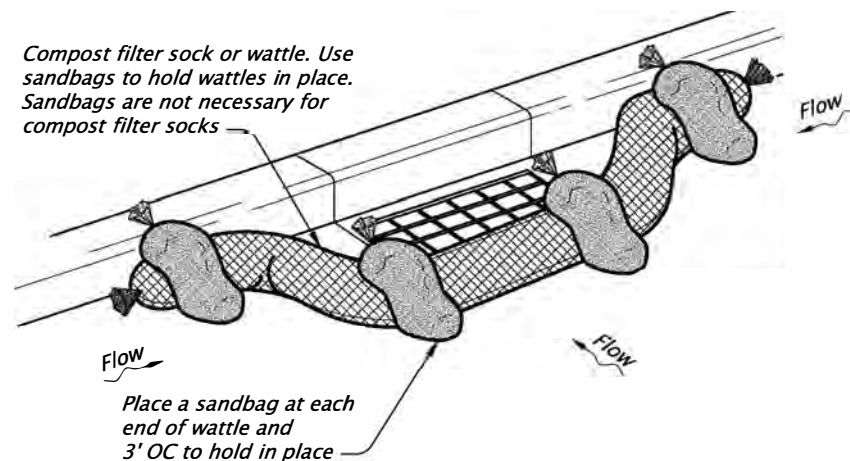
AREA DRAIN PERSPECTIVE VIEW



CURB INLET SEDIMENT DAM - TYPE 10
NOT TO SCALE



WATTLE BARRIER WITH FILTER INSERT - TYPE 11
NOT TO SCALE



COMPOST FILTER SOCK OR WATTLE - TYPE 7
NOT TO SCALE

CURB INLET PERSPECTIVE VIEW

NOTES:
Type 2 - Geotextile/wire mesh/aggregate
Place the wire mesh over the grate.
Place sediment fence geotextile over the
wire mesh and perimeter area around
structure.
Install aggregate over the geotextile fabric.

Type 3 - Prefabricated filter inserts
Install prefabricated filter inserts according
to the plans, special provisions, and
manufacturer recommendations.
Prefabricated inserts with provisions for
overflow are allowed only when
accompanied by additional BMP's to
prevent the potential of sediments
entering project storm systems.
Field fabricated inserts are not allowed.

Type 7 - Compost filter sock
Drive 2"x2" wood stakes a minimum of
6" into ground and flush with the top
of the sock.
Overlap ends of sock per manufacturers
recommendations (12" min., 36" max.).
Use 8" to 12" dia sock on curbside in traffic
areas.

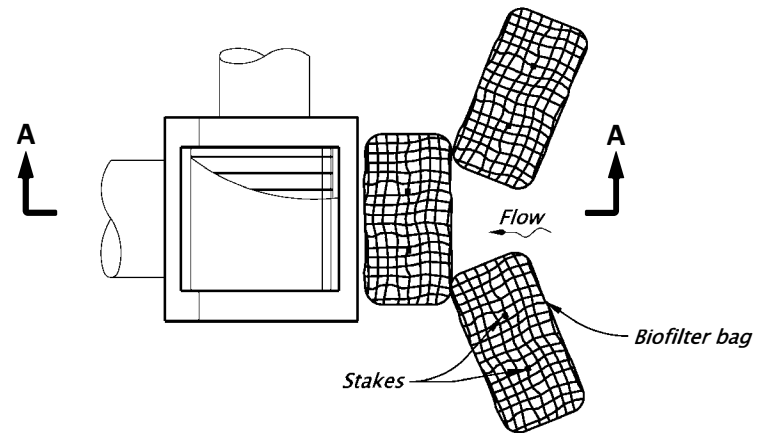
(Type 7 cont.)
Use 12" to 18" dia sock in non-traffic areas
or areas where the larger socks can be
used safely.
use synthetic mesh socks for temporary
installations.

Type 10 - Curb inlet sediment dam
Fit curb inlet sediment dam snugly into inlet
mouth. Curb inlet sediment dam is
required for use with inlet filter insert
where at-grade inlet grate and curb inlet
are combined at a catch basin.

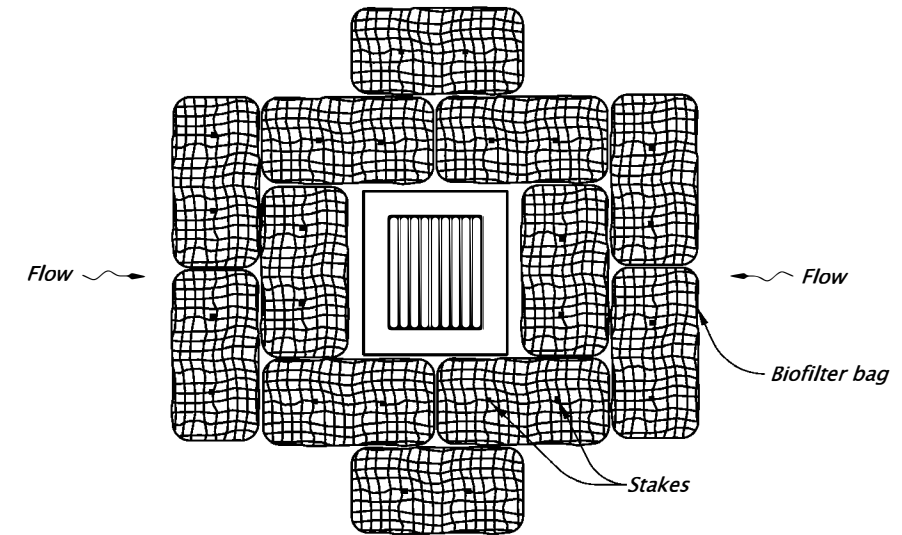
Type 11 - Wattle barrier with filter insert
Install prefabricated filter insert per Type 3
detail.
Install wattles over opening and 36" to each
side of opening tight against curb. Adjust
wattle to force storm water to flow through
filter insert or wattle prior to leaving the
site.
Adjust, replace or modify the inlet protection
as needed to prevent sediment laden water
from entering the catch basin.

CALC. BOOK NO. <u>N/A</u>	SDR DATE <u>January, 2021</u>
NOTE: All material and workmanship shall be in accordance with the current City of The Dalles Standard Specifications	
CITY OF THE DALLES STANDARD DRAWINGS	
INLET PROTECTION TYPE 2, 3, 6, 7, 10 AND 11	
2025	
DATE	REVISION DESCRIPTION
Jan 2021	Removed Calc book numbers
Jan 2021	Moved notes up from overlapping the sheet border

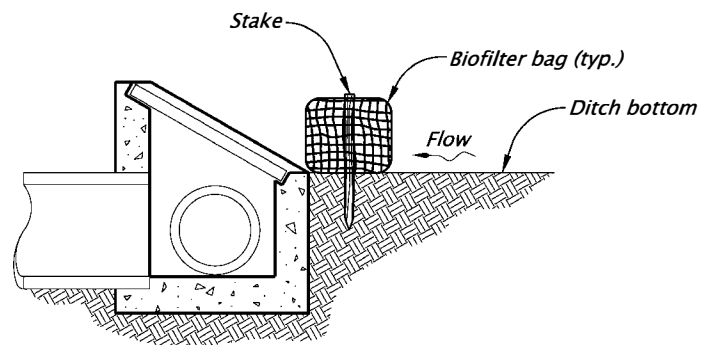
The selection and use of this Standard Drawing, while designed in accordance with generally accepted engineering principles and practices, is the sole responsibility of the user and should not be used without consulting a Registered Professional Engineer.



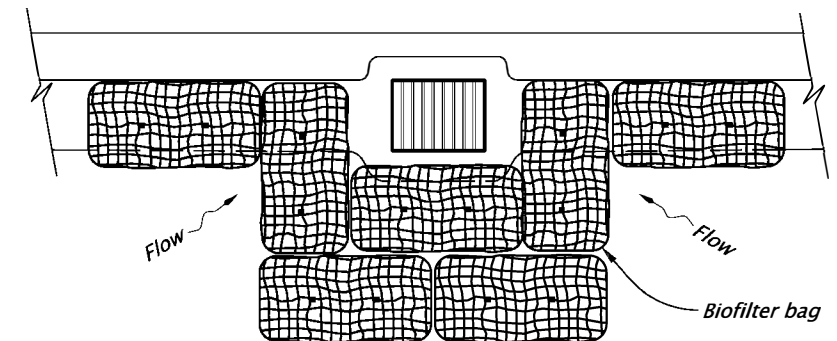
**PLAN
DITCH INLET**



**PLAN
AREA DRAIN**



**SECTION A-A
DITCH INLET**



**PLAN
CATCH BASIN**

BIOFILTER BAGS - TYPE 4
NOT TO SCALE

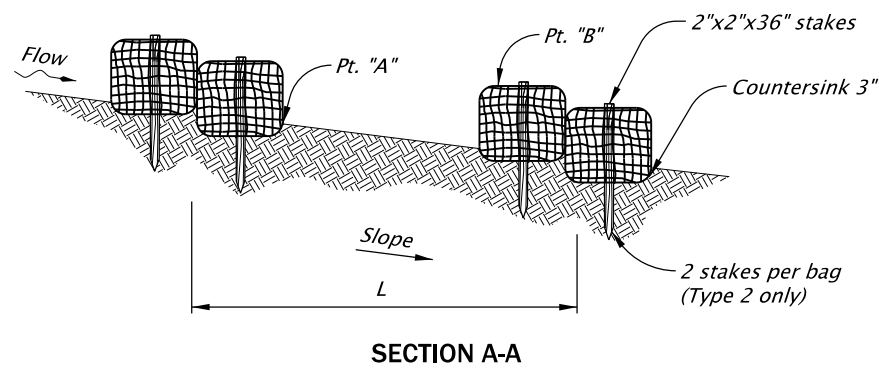
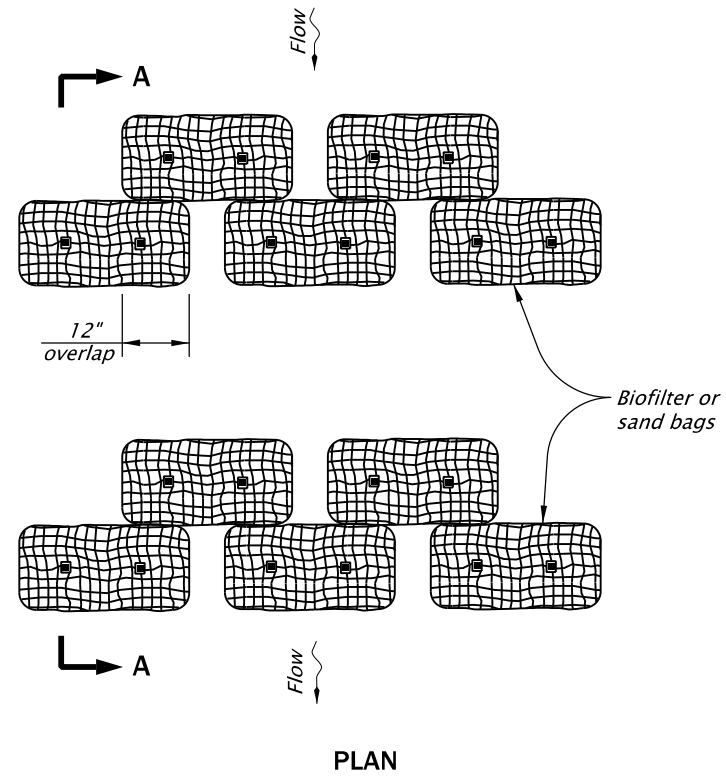
NOTES:

1. Stake biofilter bags with 2"x2"x36" wood stakes, and use a minimum 2 stakes per bag. Drive stakes a minimum of 6" into the ground and flush with the top of the bags.
2. Omit stakes when bags are placed on pavement surface.
3. Overlap all bag joints 6".

4. Biofilter bags used on active roadways are easily displaced and made ineffective if struck by vehicles. If struck by a cyclist, falls with injury could result. On active roadways alternative inlet protection should be considered.

CALC. BOOK NO. <u>N/A</u>		SDR DATE <u>January, 2021</u>	
NOTE: All material and workmanship shall be in accordance with the current City of The Dalles Standard Specifications			
CITY OF THE DALLES STANDARD DRAWINGS			
INLET PROTECTION TYPE 4			
2025			
DATE	REVISION	DESCRIPTION	
Jan 2021	Removed Calc	book numbers	

The selection and use of this Standard Drawing, while designed in accordance with generally accepted engineering principles and practices, is the sole responsibility of the user and should not be used without consulting a Registered Professional Engineer.

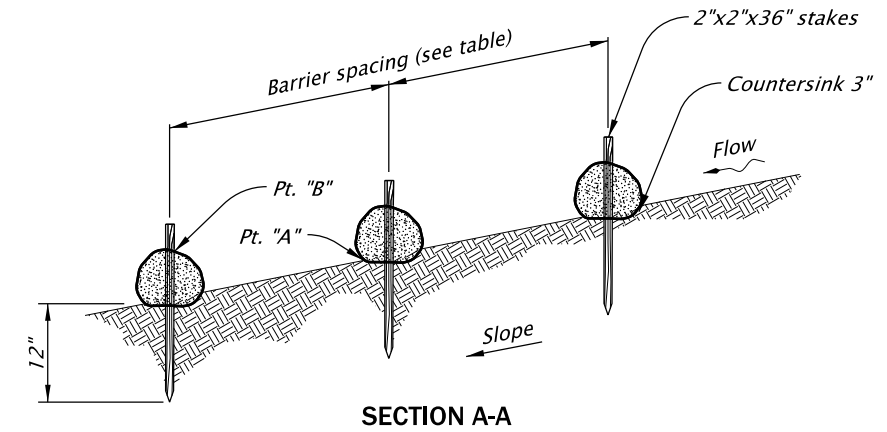
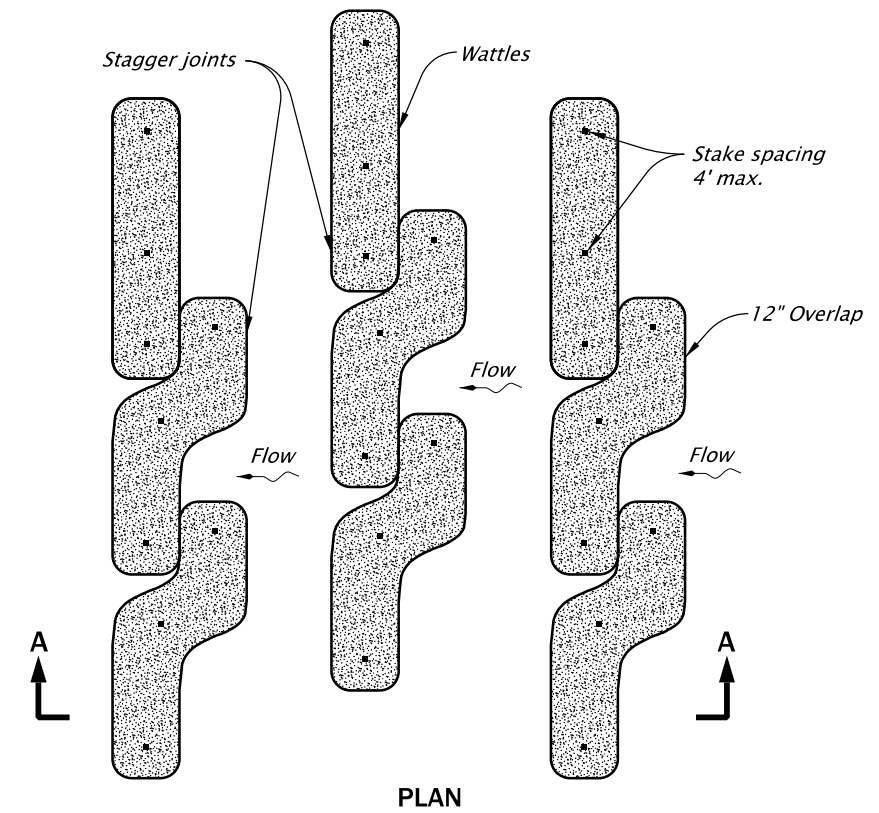


BIOFILTER BAG / SAND BAG BARRIER - TYPE 2 AND 4
NOT TO SCALE

NOTES:

1. For Type 2 barrier, drive stakes flush with top of bag and into undisturbed ground a min. of 12". Omit stakes if bags are placed on paved surface.
2. For Type 2 and Type 4 barriers, space bags (L) so that the elevation of point "A" is less than or equal to the elevation of point "B".

Type 2 - Biofilter bags
Type 3 - Wattles
Type 4 - Sand bags

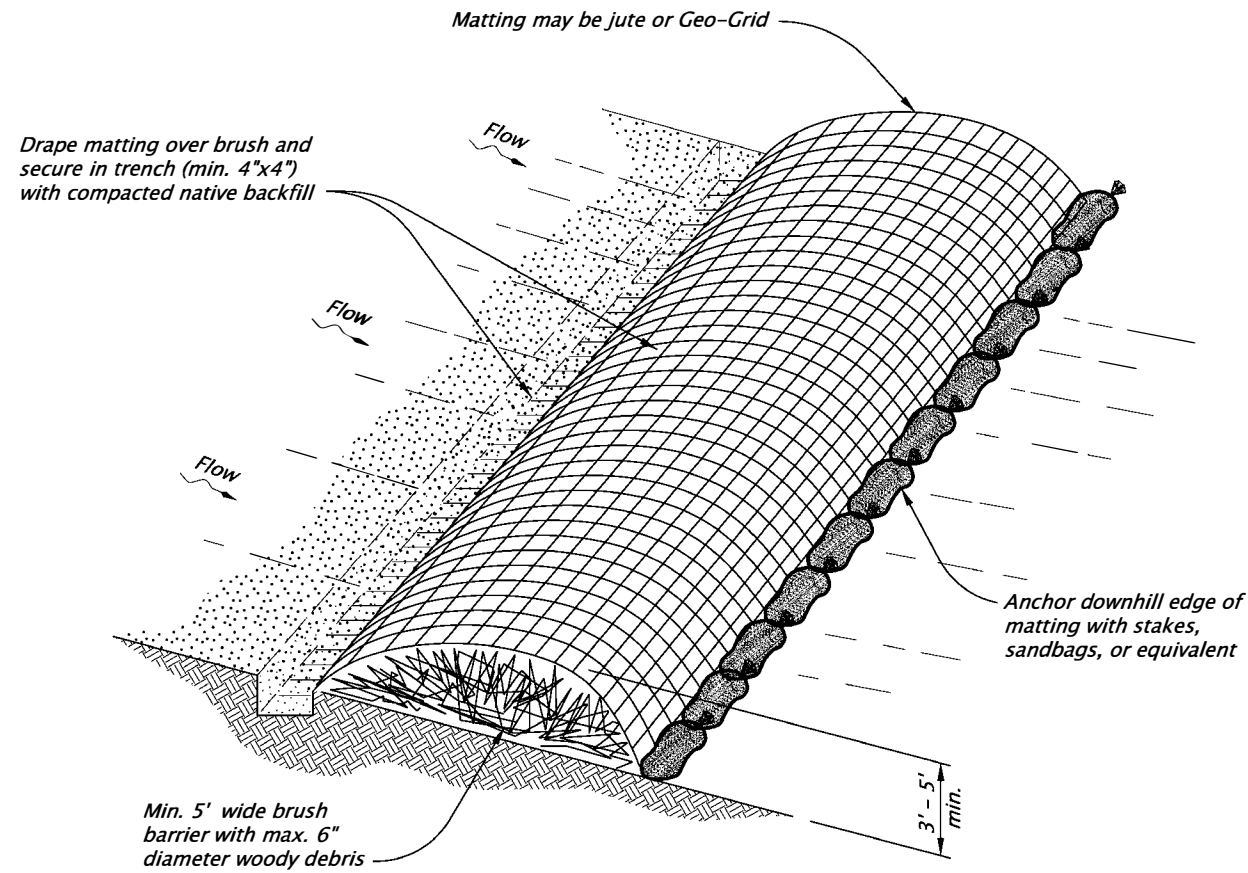


FIBER ROLL BARRIER - TYPE 3
NOT TO SCALE

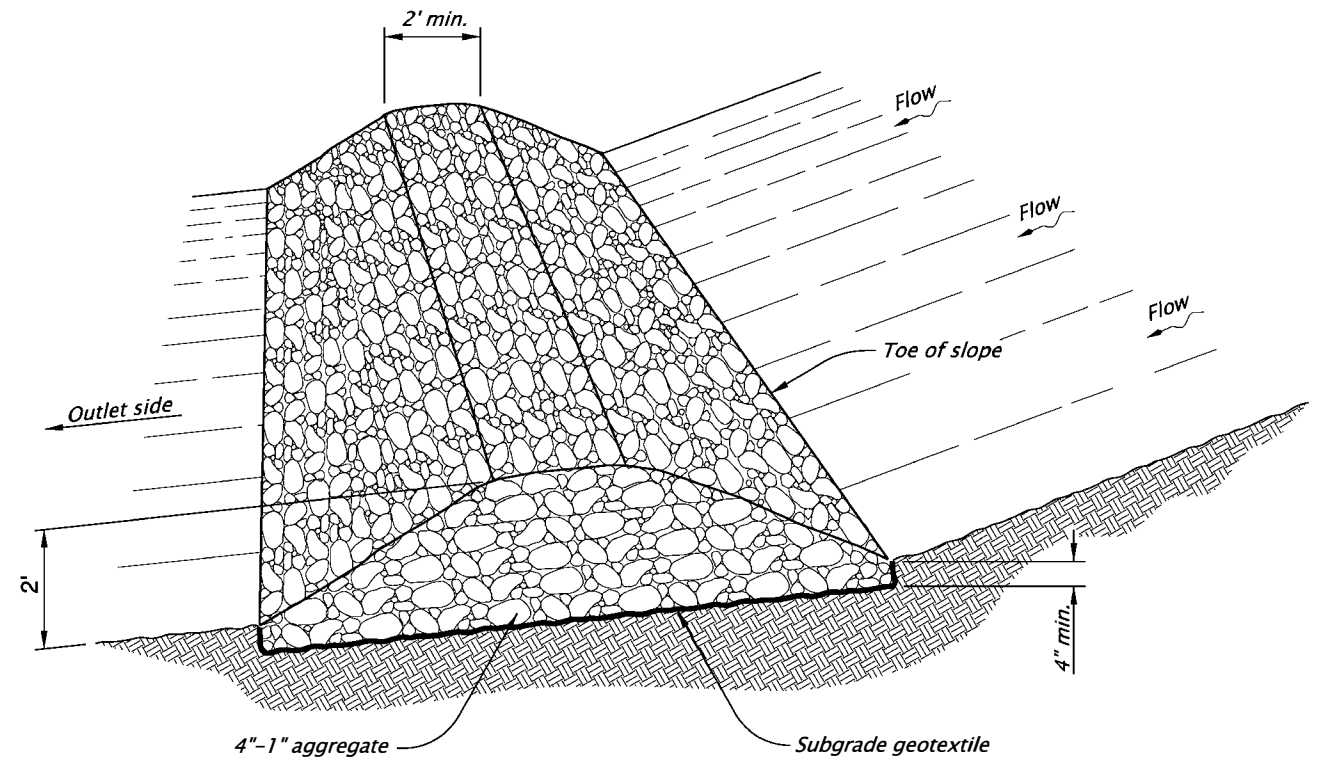
BARRIER SPACING		
INSTALL PARALLEL ALONG CONTOURS AS FOLLOWS		
% SLOPE	% SLOPE	MAXIMUM SPACING ON SLOPE
10% Flatter	1:10 or Flatter	300'
10 > % ≥ 15	10 > X ≥ 7.5	150'
15 > % ≥ 20	7.5 > X ≥ 5	100'
20 > % ≥ 30	5 > X ≥ 3	50'
Steeper than 30%	Steeper than 1:3	25'

CALC. BOOK NO. N/A		SDR DATE January, 2021	
NOTE: All material and workmanship shall be in accordance with the current City of The Dalles Standard Specifications			
CITY OF THE DALLES STANDARD DRAWINGS			
SEDIMENT BARRIER TYPE 2, 3 AND 4			
2025			
DATE	REVISION DESCRIPTION		
Jan 2021	Removed Calc book numbers		

The selection and use of this Standard Drawing, while designed in accordance with generally accepted engineering principles and practices, is the sole responsibility of the user and should not be used without consulting a Registered Professional Engineer.



BRUSH BARRIER - TYPE 5
NOT TO SCALE



AGGREGATE BARRIER - TYPE 6
NOT TO SCALE

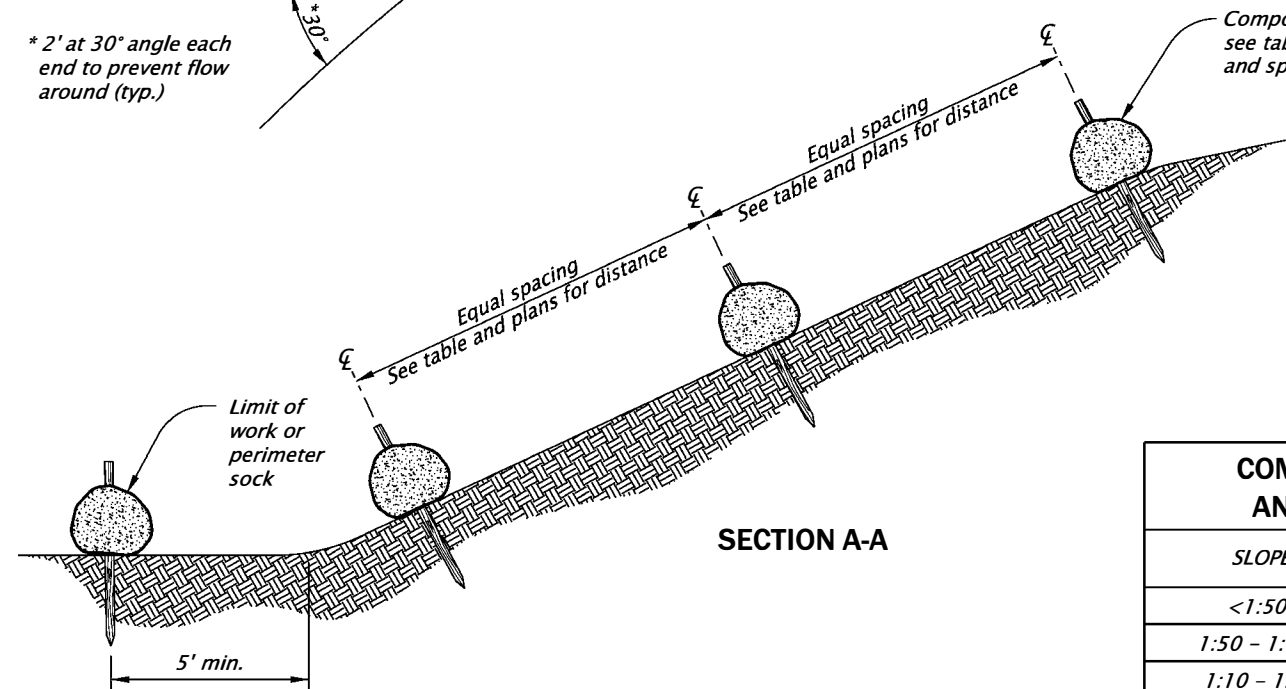
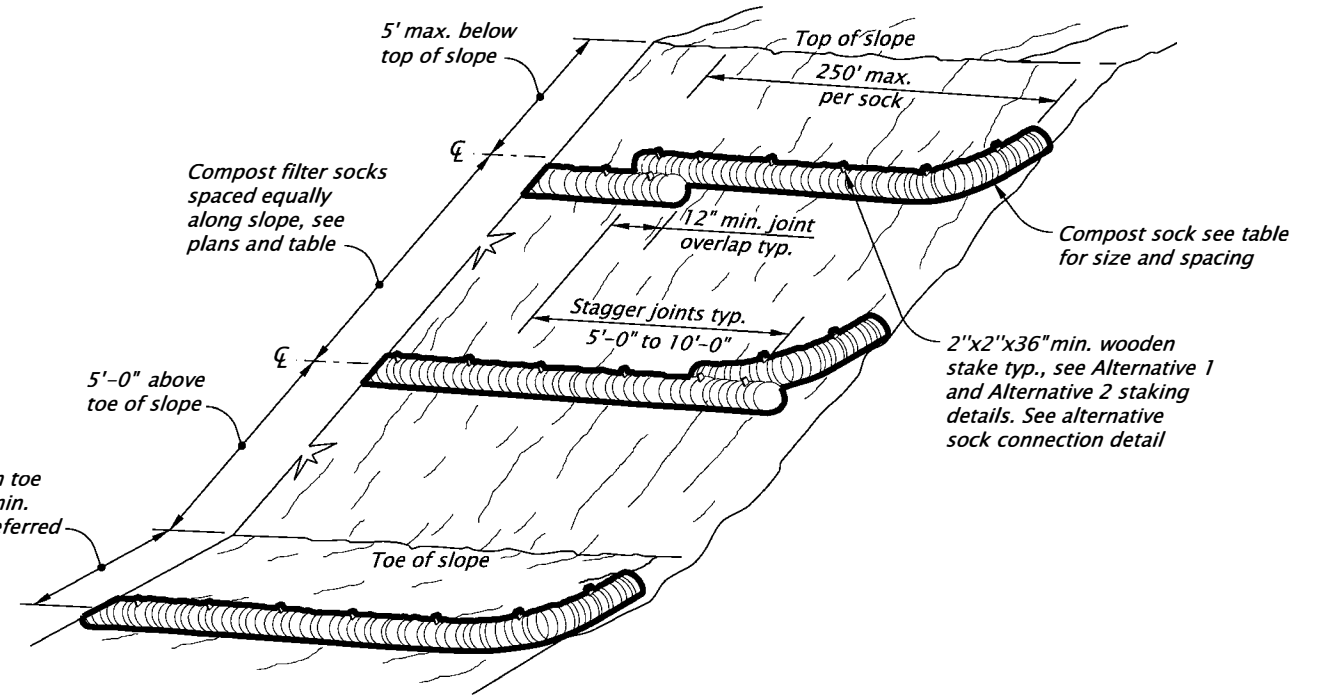
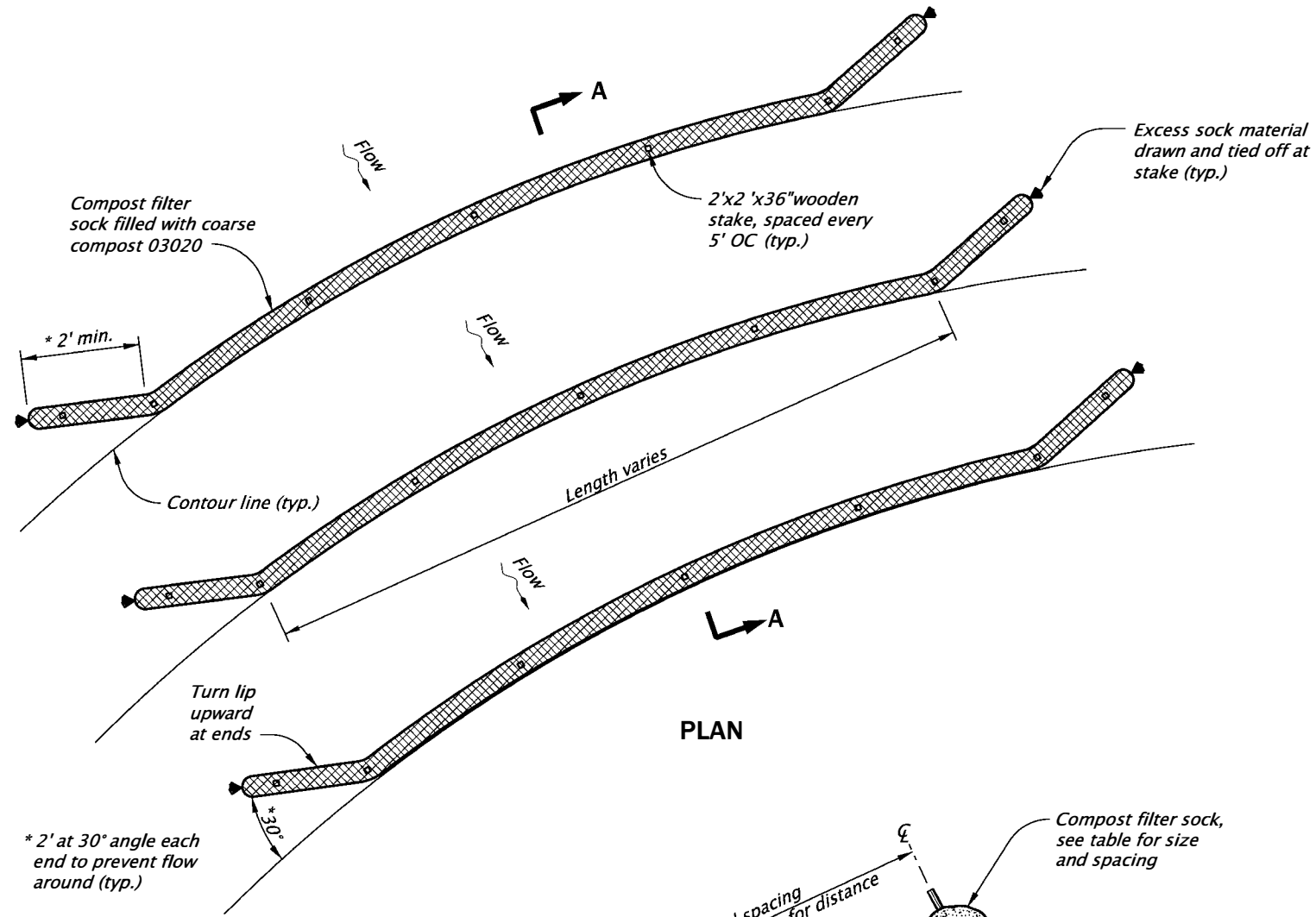
NOTES:

1. Direct diverted flows from the outlet side of the rock filter berm/dams onto a stabilized area, such as vegetation and or rock, or into a sediment trapping facility.
2. Embed barrier a min. of 4" into the existing ground/embankments.
3. Use 1:3 or flatter side slope. Within the safety clear zone, use 1:6 or flatter side slopes.
4. Use 4"-1" clean aggregate.

CALC. BOOK NO. <u>N/A</u>		SDR DATE <u>January, 2021</u>	
NOTE: All material and workmanship shall be in accordance with the current City of The Dalles Standard Specifications			
CITY OF THE DALLES STANDARD DRAWINGS			
SEDIMENT BARRIER TYPE 5 AND 6			
2025			
DATE	REVISION	DESCRIPTION	
Jan 2021	Removed Calc book numbers		

The selection and use of this Standard Drawing, while designed in accordance with generally accepted engineering principles and practices, is the sole responsibility of the user and should not be used without consulting a Registered Professional Engineer.

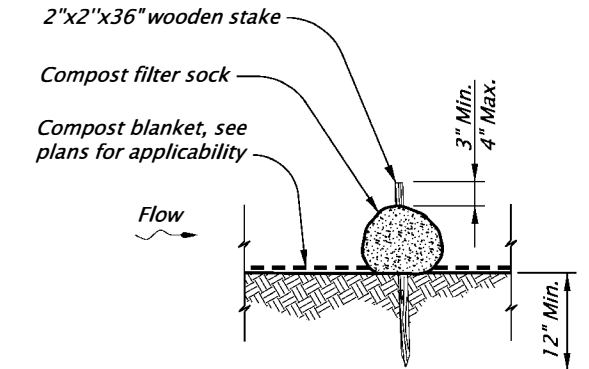
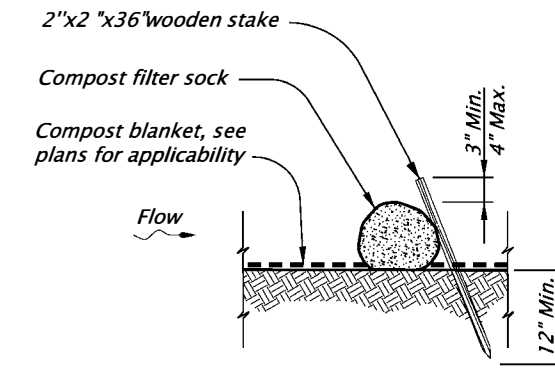
rd1032.dgn 01-20-2021



COMPOST FILTER SOCK DIAMETER AND SPACING BASED ON SLOPE		
SLOPE	SPACING (ft)	DIAMETER (in)
<1:50	250	8
1:50 - 1:10	125	12
1:10 - 1:5	100	12
1:5 - 1:2	50	18
>1:2	25	18

COMPOST FILTER SOCK
NOT TO SCALE

NOTE:
Fully biodegradable compost sock mesh is recommended for permanent installations. Where compost socks must be moved or removed, synthetic sock mesh should be used.

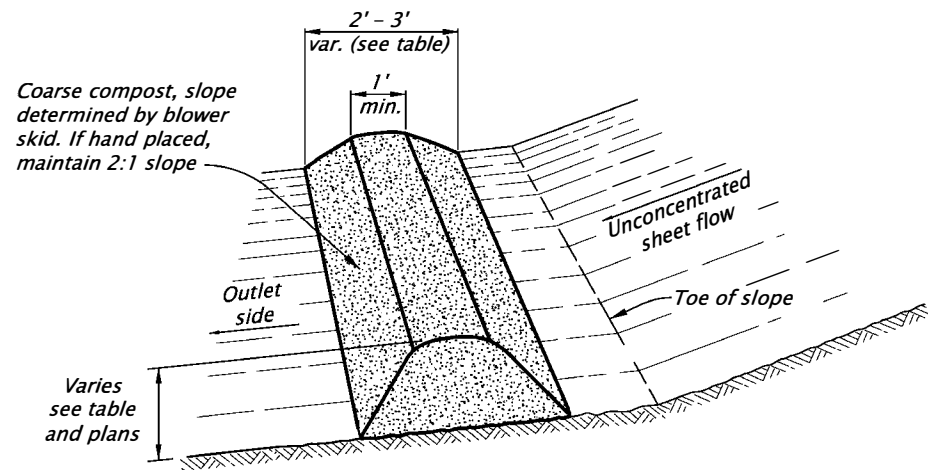


CALC. BOOK NO. N/A	SDR DATE January, 2021
NOTE: All material and workmanship shall be in accordance with the current City of The Dalles Standard Specifications	
OREGON STANDARD DRAWINGS	
SEDIMENT BARRIER TYPE 8	
2025	
DATE	REVISION DESCRIPTION
Jan 2021	Removed Calc book numbers

The selection and use of this Standard Drawing, while designed in accordance with generally accepted engineering principles and practices, is the sole responsibility of the user and should not be used without consulting a Registered Professional Engineer.

RD1032

rd1033.dgn 01-20-2021

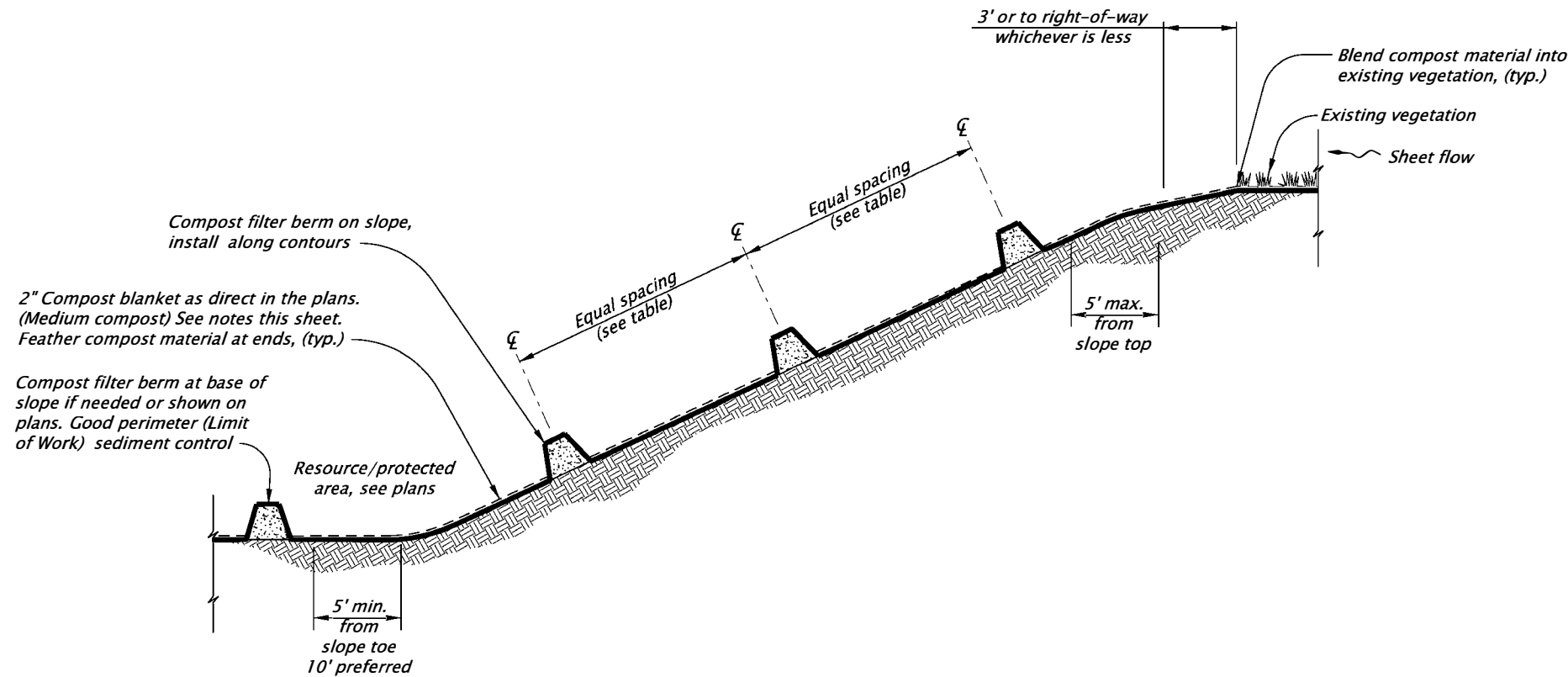


COMPOST FILTER BERM - TYPE 9
NOT TO SCALE

COMPOST FILTER BERM DIMENSIONS AND SPACING BASED ON SLOPE				
SLOPE	BERM SPACING	BERM DIMENSIONS		
		HEIGHT	BOTTOM WIDTH	TOP WIDTH
> 50:1	250 ft	1 ft	2 ft (min.)	1 ft
50:1 - 10:1	125 ft	1 ft	2 ft (min.)	1 ft
10:1 - 5:1	100 ft	1 ft	2 ft (min.)	1 ft
3:1 - 2:1	50 ft	1.3 ft	2.6 ft (min.)	1 ft
> 2:1		1.5 ft	3 ft (min.)	1 ft

NOTES:

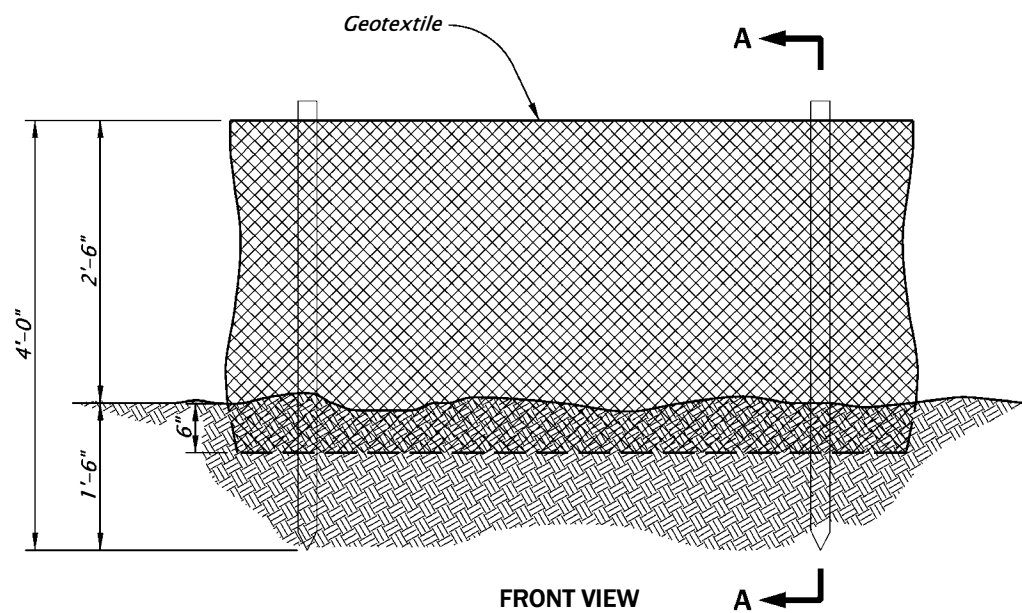
1. Compost filter berm's are sediment control devices for areas where runoff occurs as sheet flow. See Section 00280, City of The Dalles Standard Specifications.
2. The maximum drainage area for a continuous berm shall be 1/4 acre per 100 linear feet of filter berm.
3. Where possible, berm's should be placed away from the toe of slopes a minimum of 5 feet (10 feet preferred) to allow for energy dissipation and sediment storage.
4. Direct the outlet side of filter berm, located at base of slope, onto a stabilized area, such as vegetation and/or aggregate.
5. Place filter berm's along or on the ground contour with the ends of the filter berm turned up slope. Adequate area shall be provided behind berm for ponding.
6. Compost filter berm's may be vegetated with temporary or permanent seeding after placement.
7. If placed in area with existing ground vegetation, cut vegetation to 2-4 inches above grade at berm footprint. Do not remove existing vegetation or cut back outside berm footprint unless directed by Agency.
8. If soils are exposed apply compost blanket per details and specifications.



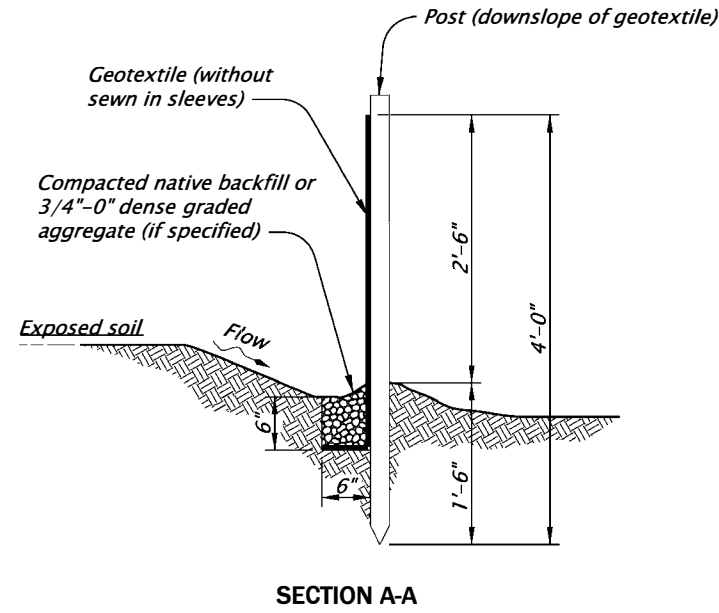
COMPOST FILTER BERM SERIES
NOT TO SCALE

CALC. BOOK NO. N/A	SDR DATE January, 2021
<p>The selection and use of this Standard Drawing, while designed in accordance with generally accepted engineering principles and practices, is the sole responsibility of the user and should not be used without consulting a Registered Professional Engineer.</p>	NOTE: All material and workmanship shall be in accordance with the current City of The Dalles Standard Specifications
	CITY OF THE DALLES STANDARD DRAWINGS
	SEDIMENT BARRIER TYPE 9
	2025
DATE	REVISION DESCRIPTION
Jan 2021	Removed Calc book numbers

RD1033

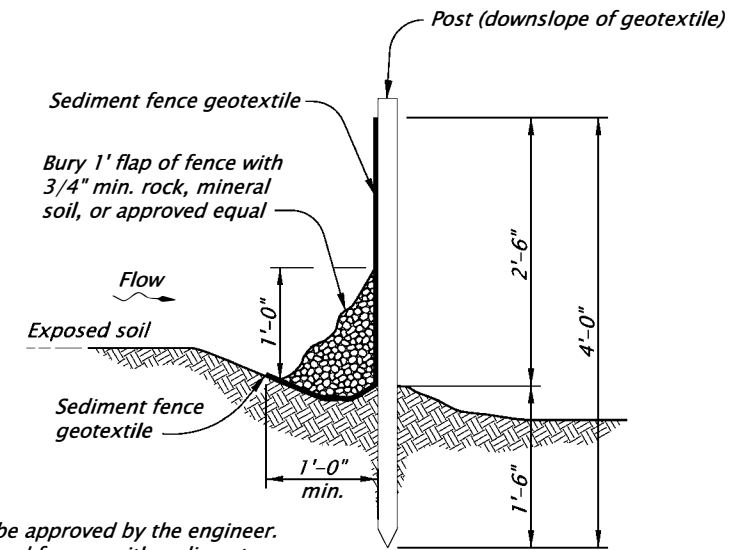


FRONT VIEW



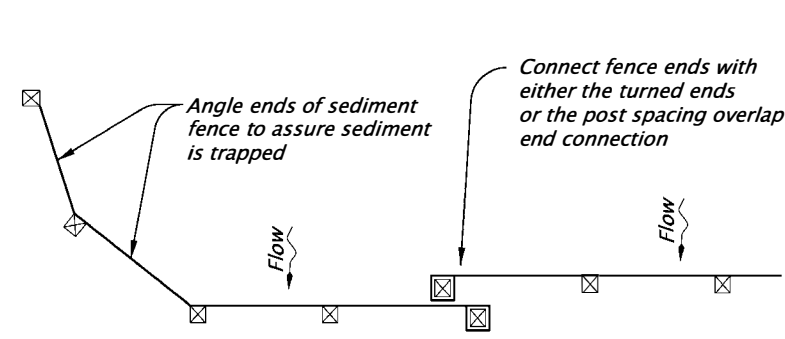
SECTION A-A

SEDIMENT FENCE AND GEOTEXTILE BURY DETAIL - TYPE 1
NOT TO SCALE

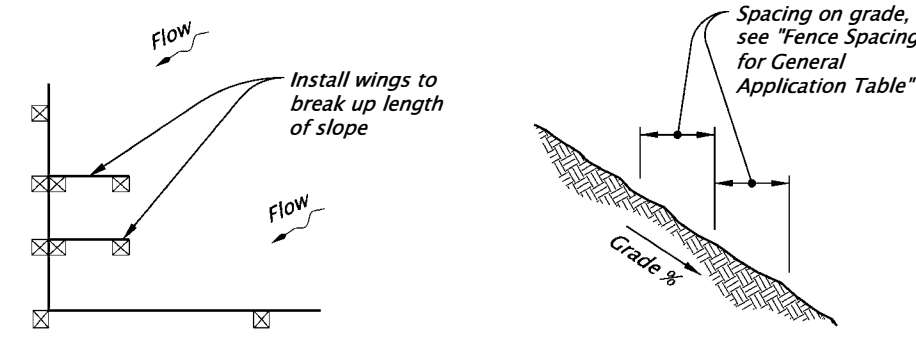


ALTERNATE SEDIMENT FENCE WITHOUT TRENCHING - TYPE 2
NOT TO SCALE

- NOTES:
 1. Use must be approved by the engineer.
 2. Not approved for use with sediment fencing with sewn-in post sleeves.



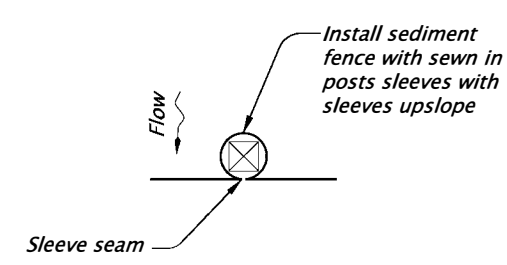
PLAN VIEW



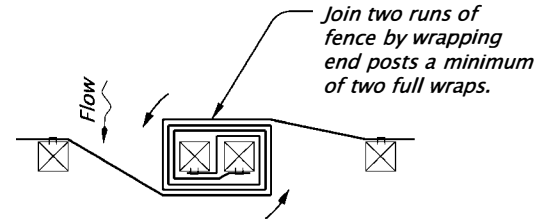
TERMINATION AT CORNER OR PROPERTY LINE

- GENERAL NOTES:
 1. Use 2"x2" wood fence posts.
 2. Posts to be installed on downhill side of sediment fence geotextile. Position posts to prevent separation from geotextile.
 3. Compact filter fabric trench backfill and soil on uphill side of fence.
 4. Locate fence no closer than three feet to the toe of a slope.
 5. Wing spacing shall comply with "Fence Spacing for General Application Table".

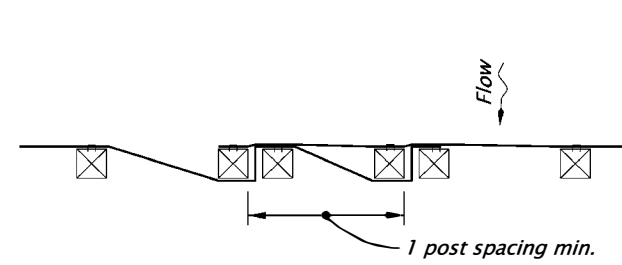
FENCE SPACING FOR GENERAL APPLICATION TABLE	
INSTALL PARALLEL ALONG CONTOURS AS FOLLOWS	
GRADE	MAXIMUM SPACING ON GRADE
Grade < 10%	300'
10% ≤ Grade < 15%	150'
15% ≤ Grade < 20%	100'
20% ≤ Grade < 30%	50'
30% ≤ Grade	25'



GEOTEXTILE WITH POST SLEEVES



TURNED ENDS CONNECTION



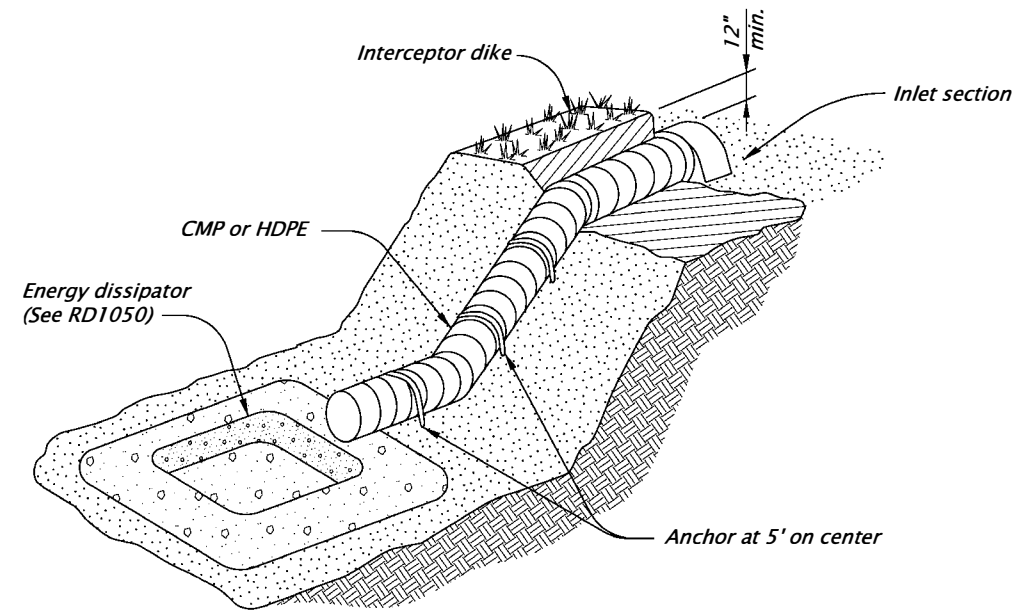
POST SPACING OVERLAP CONNECTION

GEOTEXTILE END CONNECTIONS
NOT TO SCALE

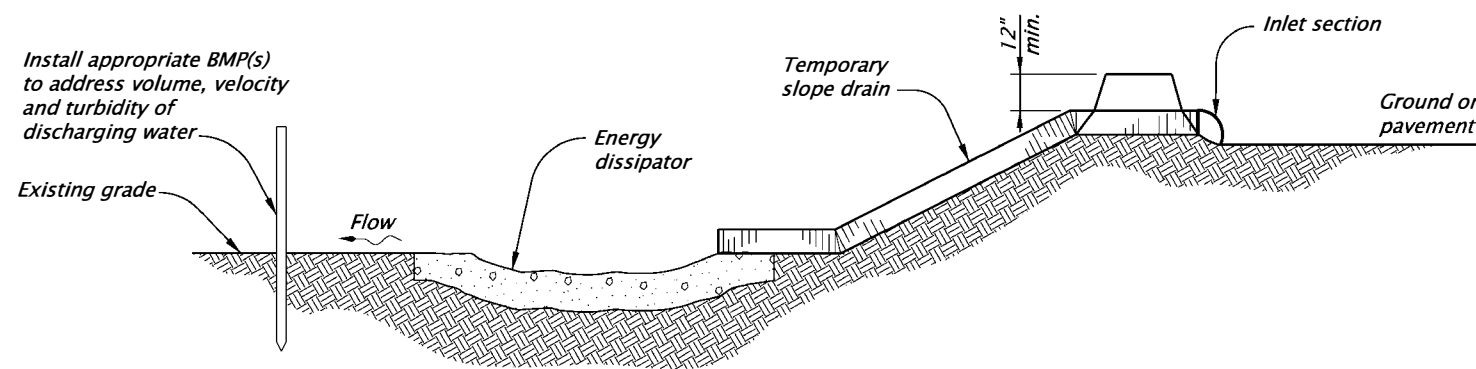
POST SPACING TABLE	
6'	Sediment Fence with Geotextile elongation less than 50%
4'	Sediment Fence with Geotextile elongation 50% or more

CALC. BOOK NO. <u>N/A</u>	SDR DATE <u>January, 2021</u>
NOTE: All material and workmanship shall be in accordance with the current City of The Dalles Standard Specifications	
CITY OF THE DALLES STANDARD DRAWINGS	
SEDIMENT FENCE	
2025	
DATE	REVISION DESCRIPTION
Jan 2021	Removed Calc book numbers

The selection and use of this Standard Drawing, while designed in accordance with generally accepted engineering principles and practices, is the sole responsibility of the user and should not be used without consulting a Registered Professional Engineer.

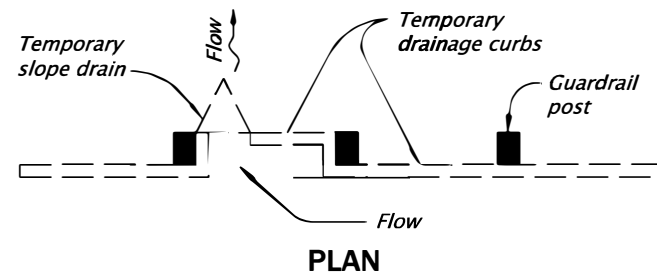


PERSPECTIVE

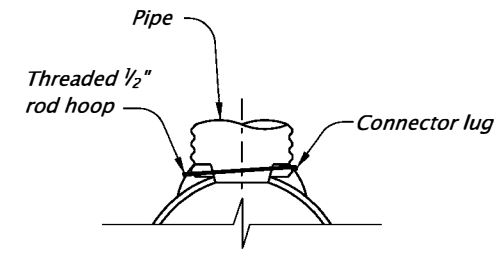


PROFILE
TEMPORARY SLOPE DRAIN
 NOT TO SCALE

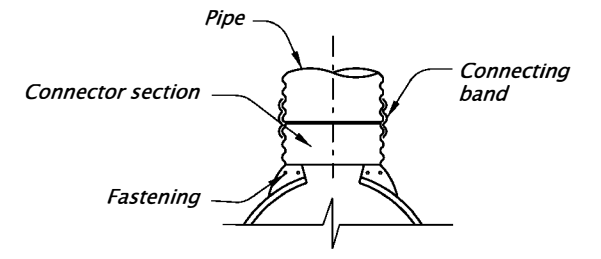
- NOTES:
1. Temporary slope drains shall be used at the top of fill slopes as the embankment is constructed to prevent erosion.
 2. Temporary drainage curbs shall be used in conjunction with temporary slope drains to prevent erosion on completed slopes and to direct flow into end section.
 3. All dimensions not indicated will be as directed.



PLAN
TEMPORARY DRAIN AT GUARDRAIL
 NOT TO SCALE

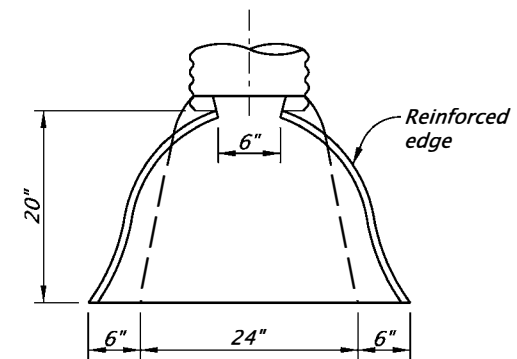


OPTION 1

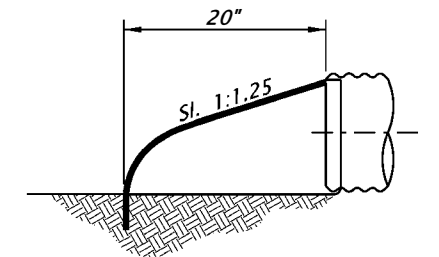


OPTION 2

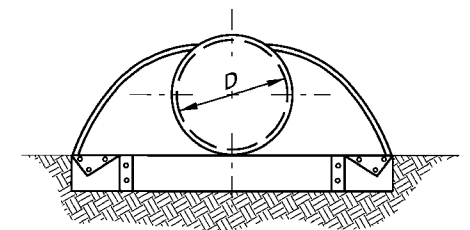
CONNECTION DETAILS
 NOT TO SCALE



PLAN



SIDE VIEW



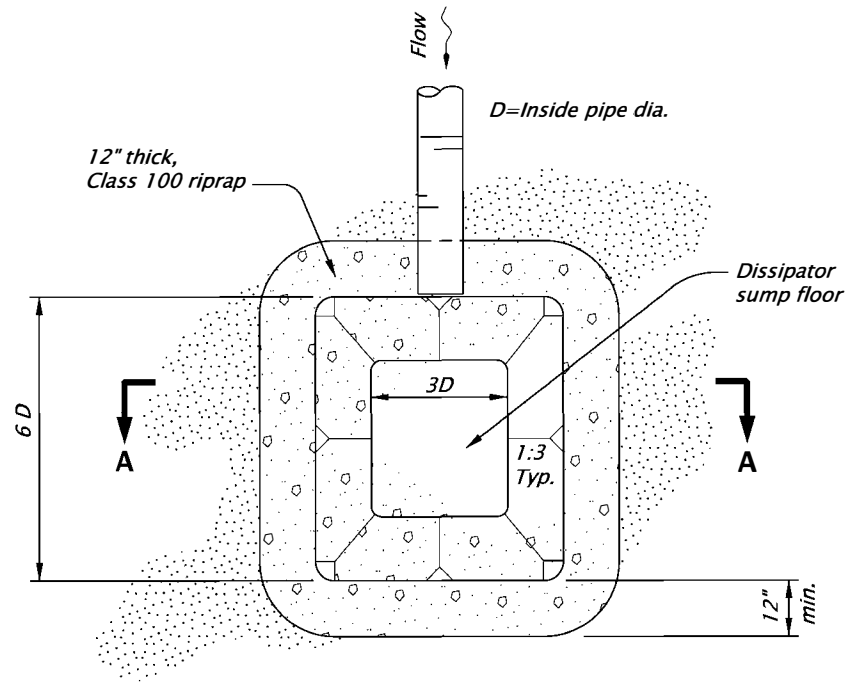
FRONT VIEW

PIPE SIZE TABLE		
PIPE		CONTRIBUTING AREA TO SLOPE DRAIN (sq ft)
Slope (min.)	D in. (min.)	
3.8%	6	A < 200
2.5%	8	200 ≤ A < 500
1.9%	10	500 ≤ A < 850
1.5%	12	850 ≤ A < 1400
-	special design reqd.	1400 ≤ A

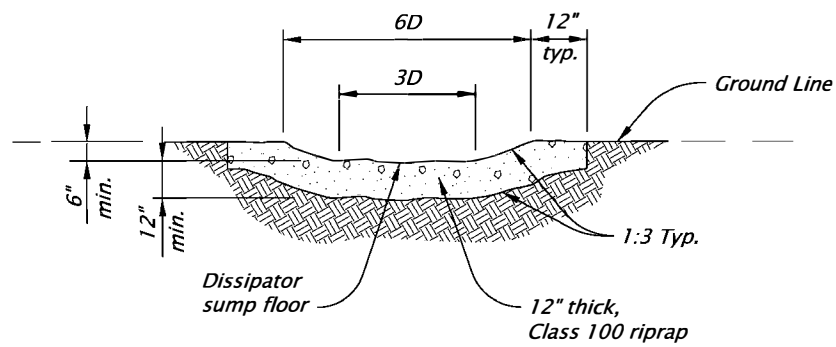
INLET SECTION DETAILS
 NOT TO SCALE

CALC. BOOK NO. <u>N/A</u>	SDR DATE <u>January, 2021</u>
NOTE: All material and workmanship shall be in accordance with the current City of The Dalles Standard Specifications	
CITY OF THE DALLES STANDARD DRAWINGS	
TEMPORARY SLOPE DRAIN WITH ENERGY DISSIPATOR	
2025	
DATE	REVISION DESCRIPTION
Jan 2021	Removed Calc book numbers

The selection and use of this Standard Drawing, while designed in accordance with generally accepted engineering principles and practices, is the sole responsibility of the user and should not be used without consulting a Registered Professional Engineer.



PLAN



SECTION A-A

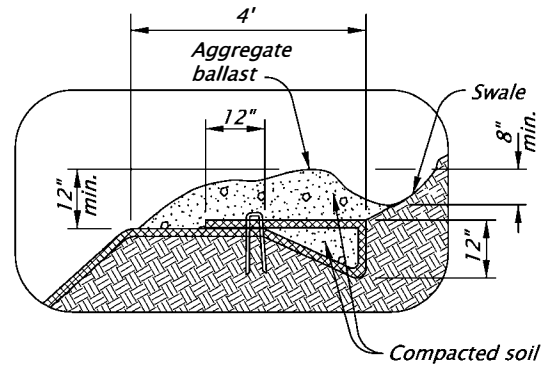
- NOTES:
1. All dimensions not indicated will be as directed.
 2. Install level spreader, sediment barrier(s), check dam(s) or other appropriate BMP(s) to address volume, velocity and turbidity of discharge water.

TEMPORARY SCOUR BASIN / ENERGY DISSIPATOR
NOT TO SCALE

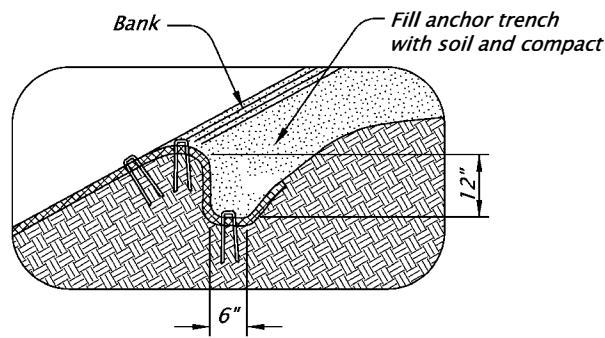
CALC. BOOK NO. <u>N/A</u>	SDR DATE <u>January, 2021</u>
<p><i>The selection and use of this Standard Drawing, while designed in accordance with generally accepted engineering principles and practices, is the sole responsibility of the user and should not be used without consulting a Registered Professional Engineer.</i></p>	NOTE: All material and workmanship shall be in accordance with the current City of The Dalles Standard Specifications
	CITY OF THE DALLES STANDARD DRAWINGS
	TEMPORARY SCOUR BASIN / ENERGY DISSIPATOR
	2025
DATE	REVISION DESCRIPTION
Jan 2021	Removed Calc book numbers

rd1055.dgn 01-20-2021

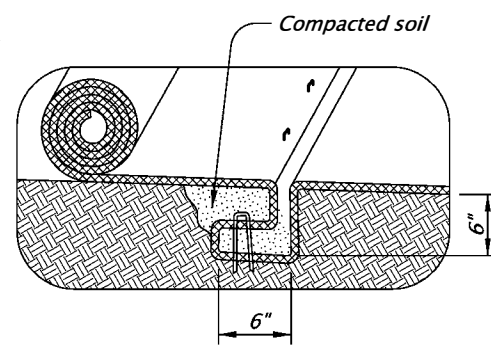
RD1055



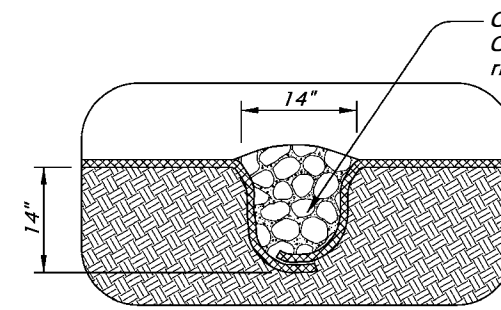
**FIGURE A1:
TOP OF BANK ANCHOR TRENCH,
H>3' AND TERMINAL SLOPE**
NOT TO SCALE



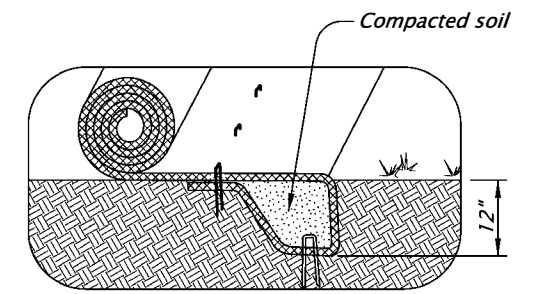
**FIGURE A2:
TOP OF BANK
ANCHOR TRENCH, H<3'**
NOT TO SCALE



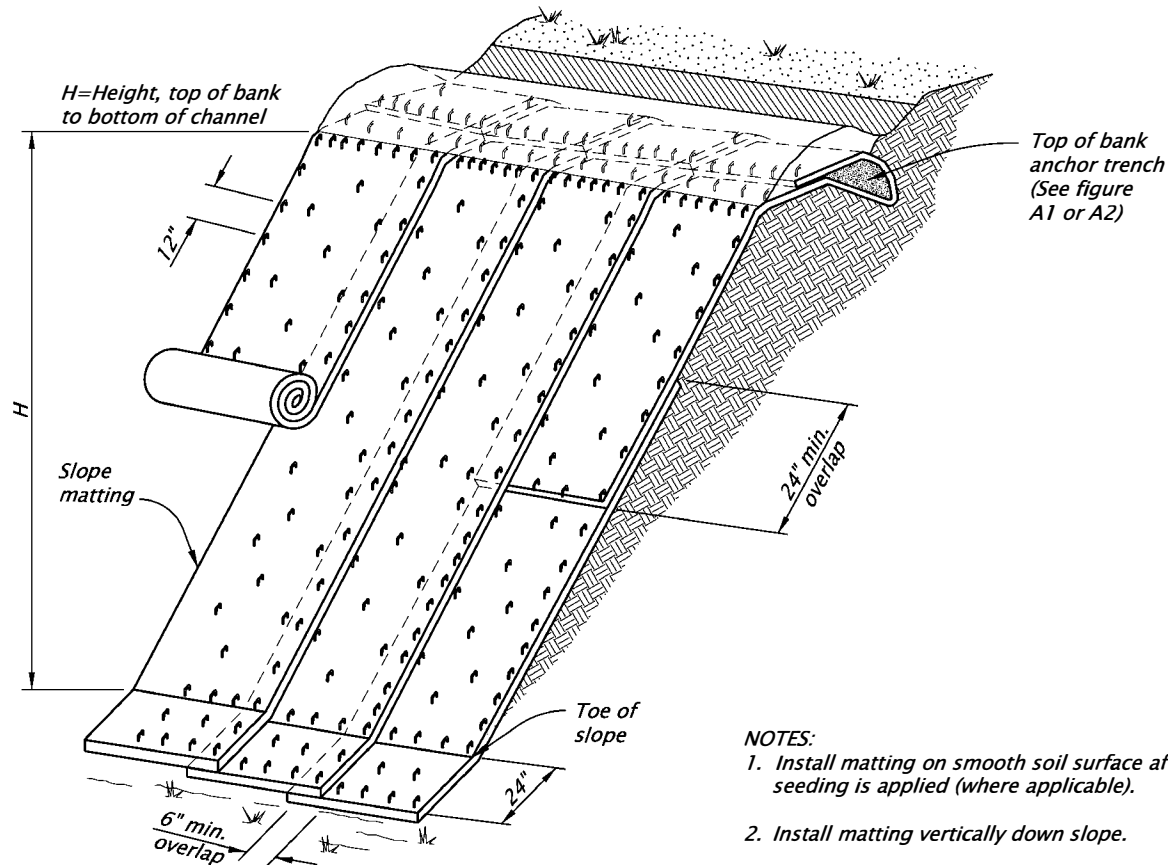
**FIGURE A3:
CHANNEL CHECK SLOT**
NOT TO SCALE



**FIGURE A4:
CHANNEL CHECK SLOT WITH
ROCK BACKFILL**
NOT TO SCALE

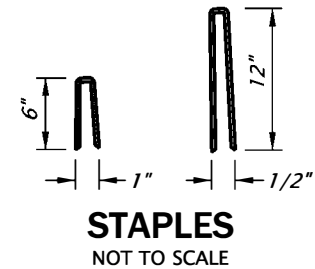


**FIGURE A5:
INITIAL CHANNEL
ANCHOR TRENCH**
NOT TO SCALE



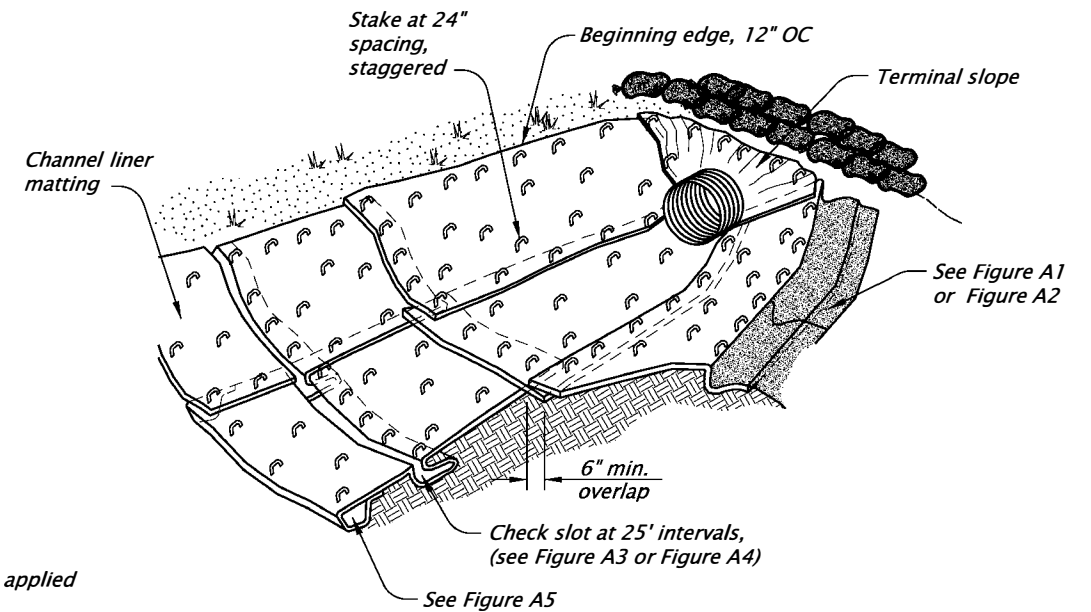
SLOPE MATTING ISOMETRIC VIEW
NOT TO SCALE

- NOTES:**
1. Install matting on smooth soil surface after seeding is applied (where applicable).
 2. Install matting vertically down slope.
 3. Install matting so edge overlaps are shingled away from prevailing winds.
 4. Place fastener at 12" OC on matting edges
 5. Overlap upper mat over lower mat, and fasten.
 6. Stagger alternate rows of fasteners placed at 24" OC
 7. Extend mat 24" beyond toe of slope; fold mat back under 4" and fasten.
 8. Matting Types A through E: Furnish fully biodegradable product. Matting with plastic or photodegradable components will not be accepted.



STAPLES
NOT TO SCALE

- NOTES:**
1. Install matting on smooth soil surface after seeding is applied (where applicable).
 2. Install channel liner matting, in the direction of water flow. Anchor upstream end of mat with check slot for culvert outfalls, place mat under pipe 12" minimum upstream from pipe outlet.
 3. Construct check slots across channel bottom at 25' spacing and at the end of each mat (Fig. A3 or A4).
 4. Overlap side channel liner matting edges 6" over the center channel liner matting and fasten edges 12" OC. Continue overlap and stapling pattern for each additional side channel liner mat.
 5. Lap upstream matting end 12" over beginning edge of downstream matting. Fasten 12" OC
 6. Anchor top edge of side channel matting in trench and fasten 12" OC (Fig. A2).
 7. Fasten matting interior at 24" OC with staggered spacing.
 8. Construct initial anchor trench at downstream end of matting and terminal slope anchor at upstream end.
 9. Matting Types A through E: Furnish fully biodegradable product. Matting with plastic or photodegradable components will not be accepted.



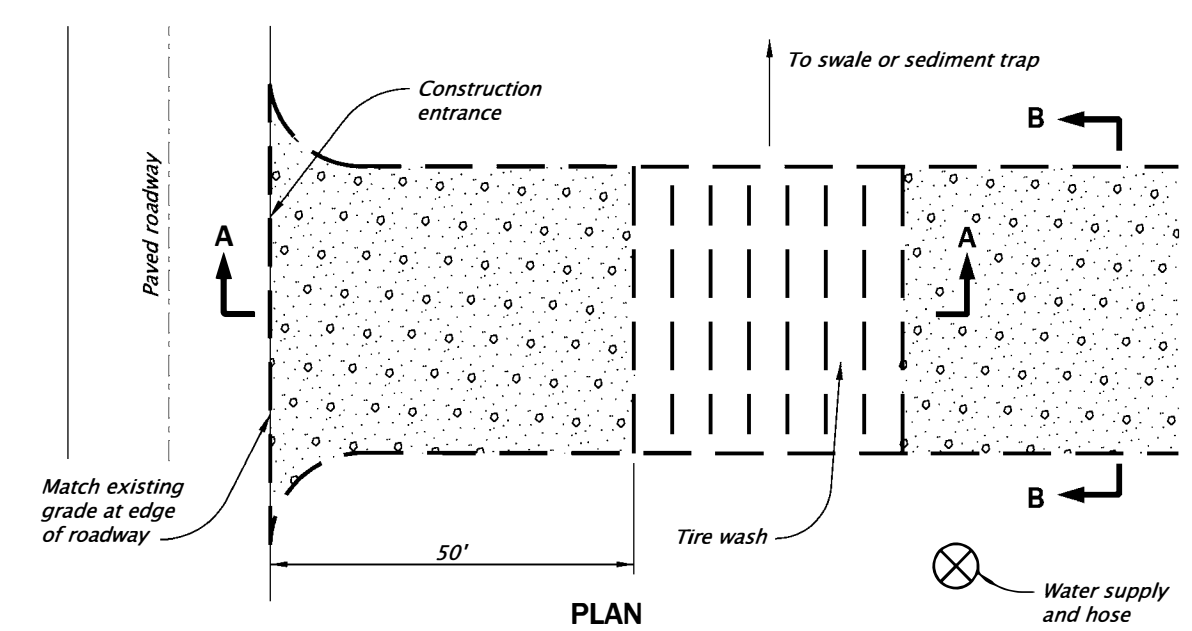
CHANNEL MATTING ISOMETRIC VIEW
NOT TO SCALE

CALC. BOOK NO. <u> N/A </u>		SDR DATE <u> January, 2021 </u>	
NOTE: All material and workmanship shall be in accordance with the current City of The Dalles Standard Specifications			
CITY OF THE DALLES STANDARD DRAWINGS			
SLOPE AND CHANNEL			
MATTING			
2025			
DATE	REVISION	DESCRIPTION	
Jan 2021	Removed Calc book numbers		

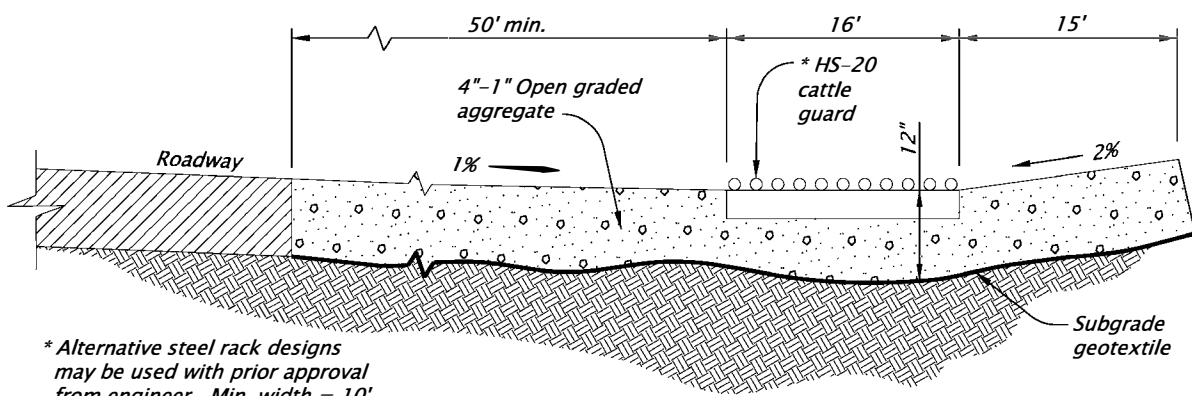
The selection and use of this Standard Drawing, while designed in accordance with generally accepted engineering principles and practices, is the sole responsibility of the user and should not be used without consulting a Registered Professional Engineer.

rd1060.dgn 01-20-2021

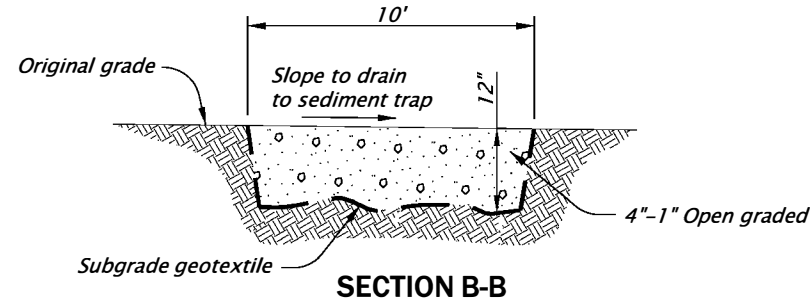
RD1060



PLAN

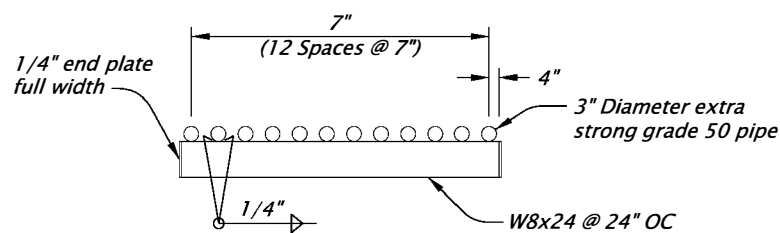


SECTION A-A



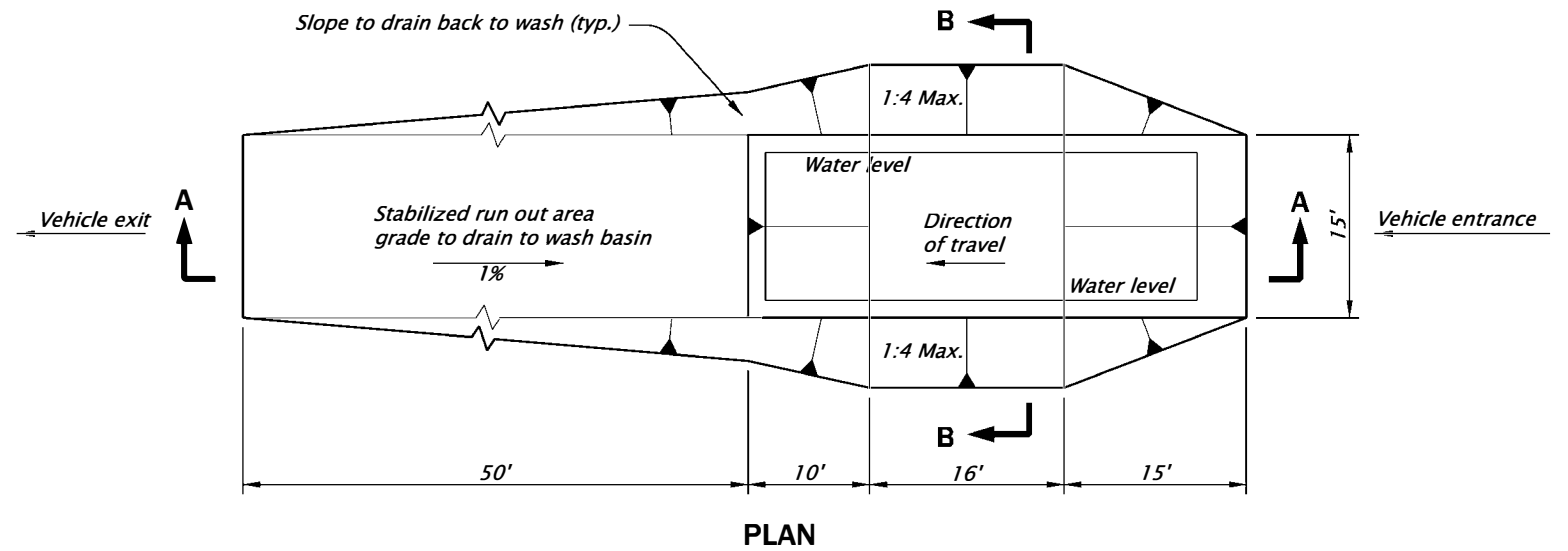
SECTION B-B

TIRE WASH - TYPE 1 (MANUAL HOSE WASH)
NOT TO SCALE

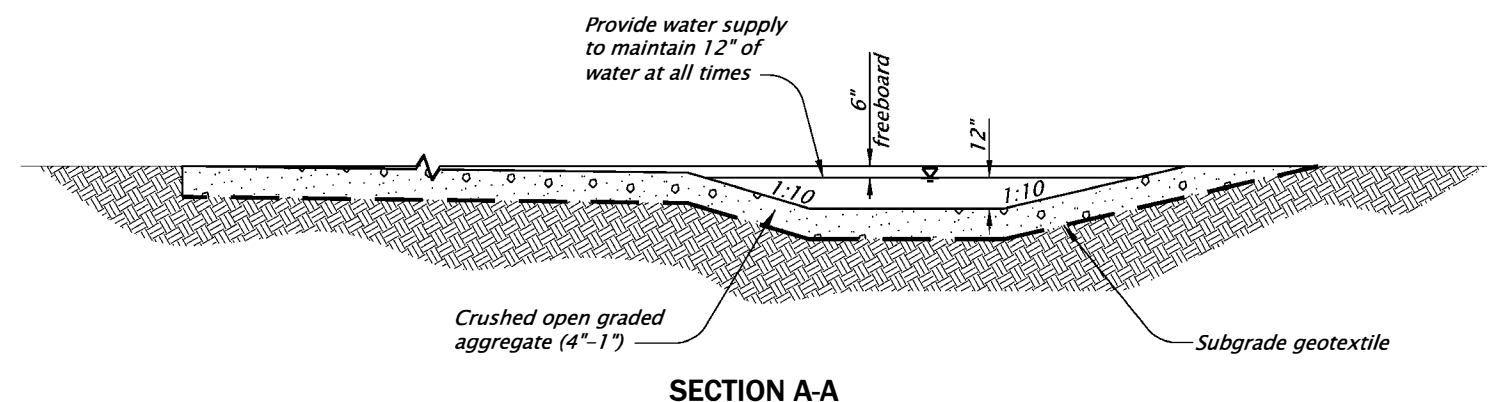


HS-20 CATTLE GUARD
NOT TO SCALE

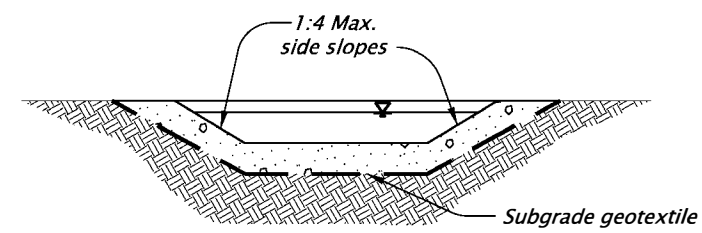
* Alternative steel rack designs may be used with prior approval from engineer. Min. width = 10'



PLAN



SECTION A-A

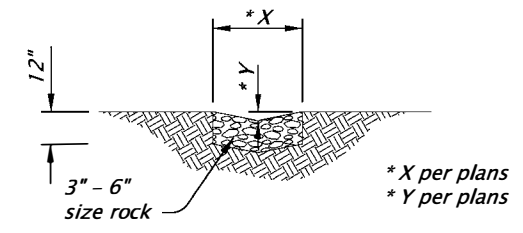
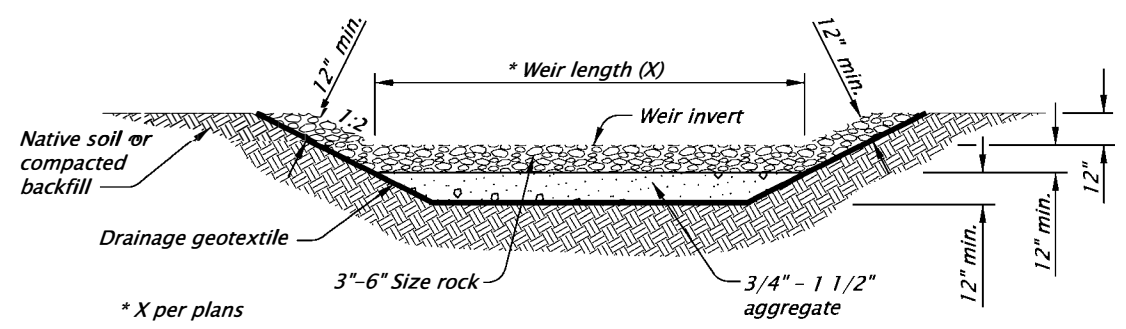
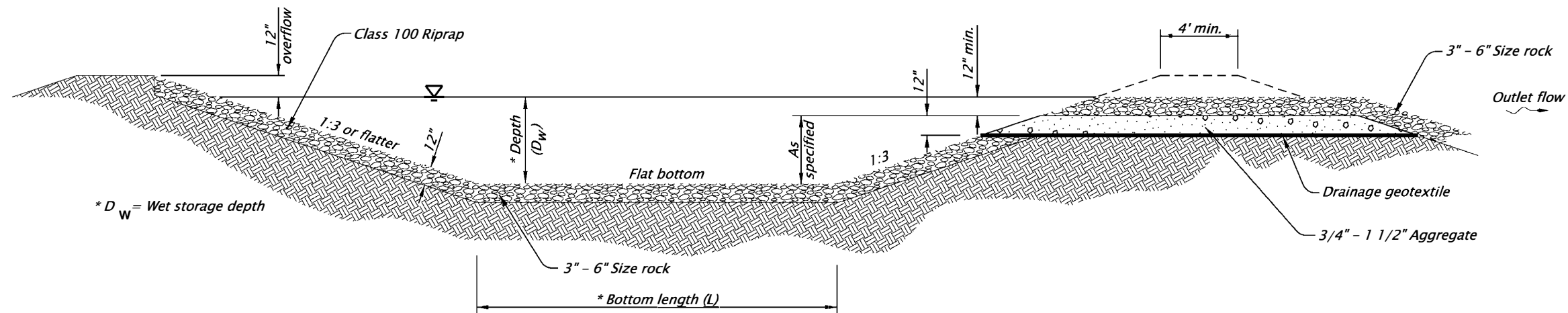
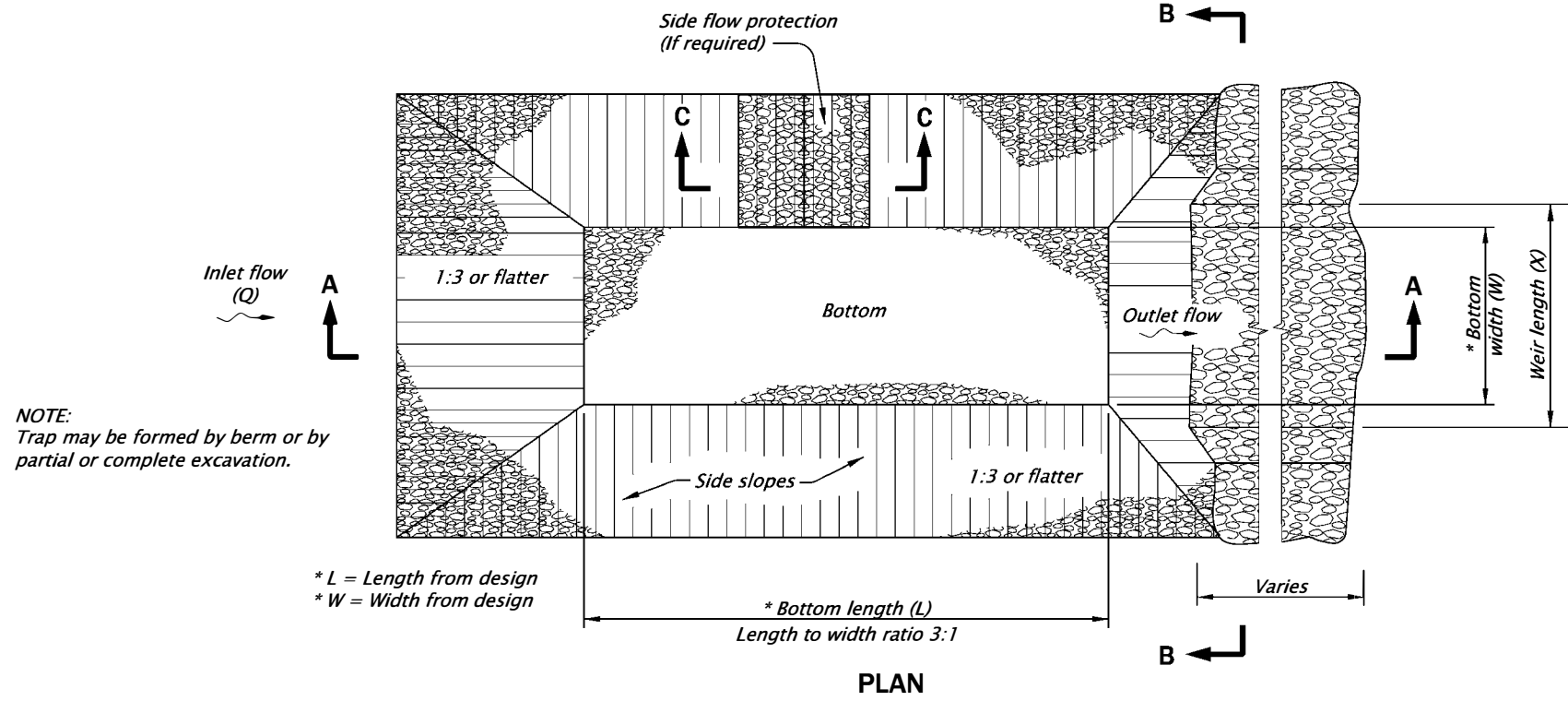


SECTION B-B

TIRE WASH - TYPE 2
NOT TO SCALE

CALC. BOOK NO. <u>N/A</u>	SDR DATE <u>January, 2021</u>
NOTE: All material and workmanship shall be in accordance with the current City of The Dalles Standard Specifications	
CITY OF THE DALLES STANDARD DRAWINGS	
TIRE WASH FACILITY TYPE 1 AND 2	
2025	
DATE	REVISION DESCRIPTION
Jan 2021	Removed Calc book numbers

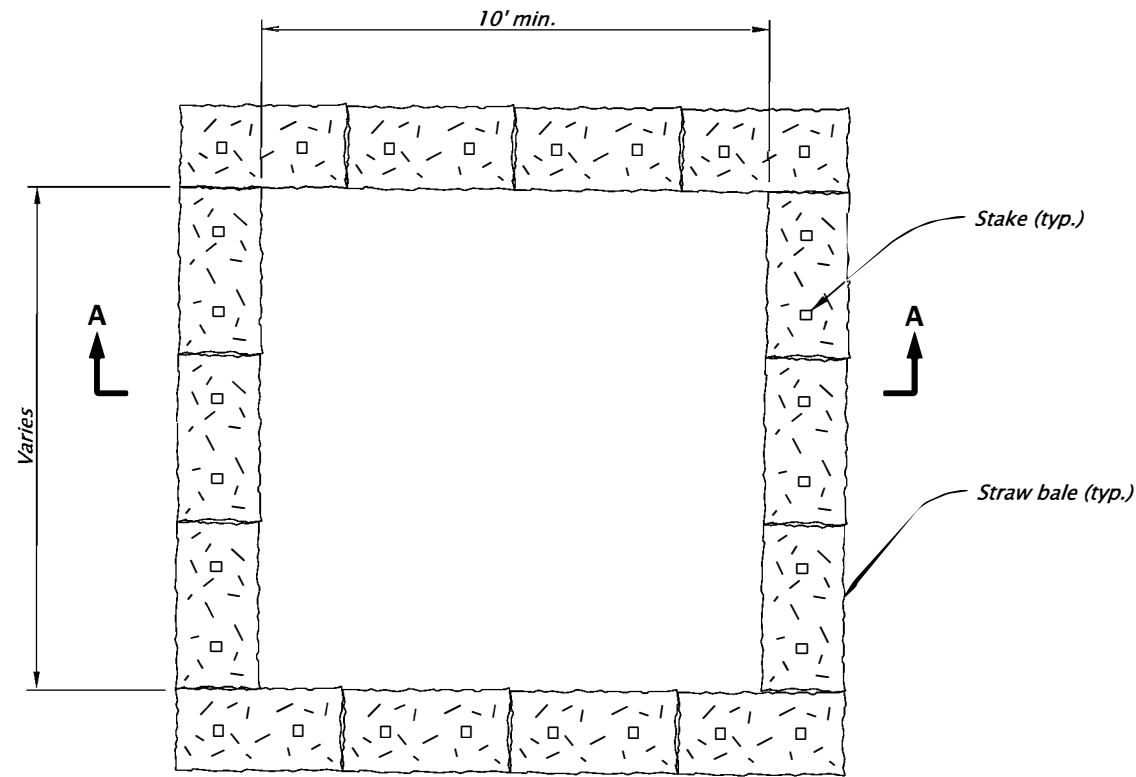
The selection and use of this Standard Drawing, while designed in accordance with generally accepted engineering principles and practices, is the sole responsibility of the user and should not be used without consulting a Registered Professional Engineer.



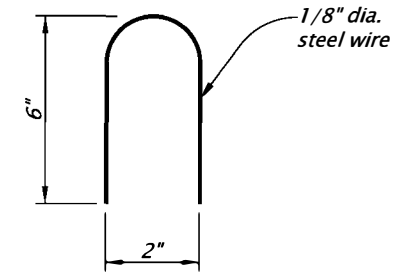
SEDIMENT TRAP
NOT TO SCALE

CALC. BOOK NO. <u>N/A</u>	SDR DATE <u>January, 2021</u>														
<p>The selection and use of this Standard Drawing, while designed in accordance with generally accepted engineering principles and practices, is the sole responsibility of the user and should not be used without consulting a Registered Professional Engineer.</p>	NOTE: All material and workmanship shall be in accordance with the current City of The Dalles Standard Specifications														
	CITY OF THE DALLES STANDARD DRAWINGS														
	SEDIMENT TRAP														
	2025														
	<table border="1"> <thead> <tr> <th>DATE</th> <th>REVISION</th> <th>DESCRIPTION</th> </tr> </thead> <tbody> <tr> <td>Jan 2021</td> <td>Removed Calc book numbers</td> <td></td> </tr> <tr> <td></td> <td></td> <td></td> </tr> <tr> <td></td> <td></td> <td></td> </tr> <tr> <td></td> <td></td> <td></td> </tr> </tbody> </table>	DATE	REVISION	DESCRIPTION	Jan 2021	Removed Calc book numbers									
DATE	REVISION	DESCRIPTION													
Jan 2021	Removed Calc book numbers														

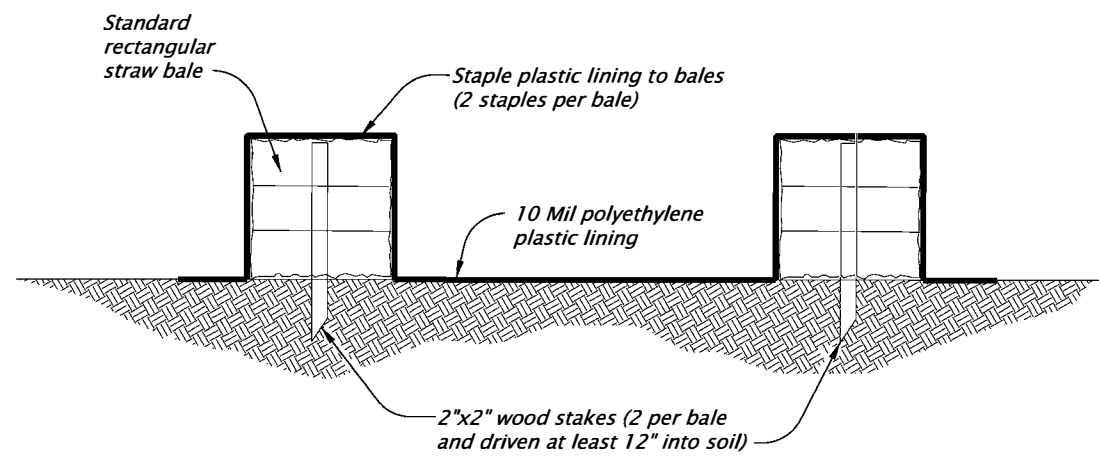
rd1070.dgn 01-20-2021



PLAN



STAPLE DETAIL
NOT TO SCALE



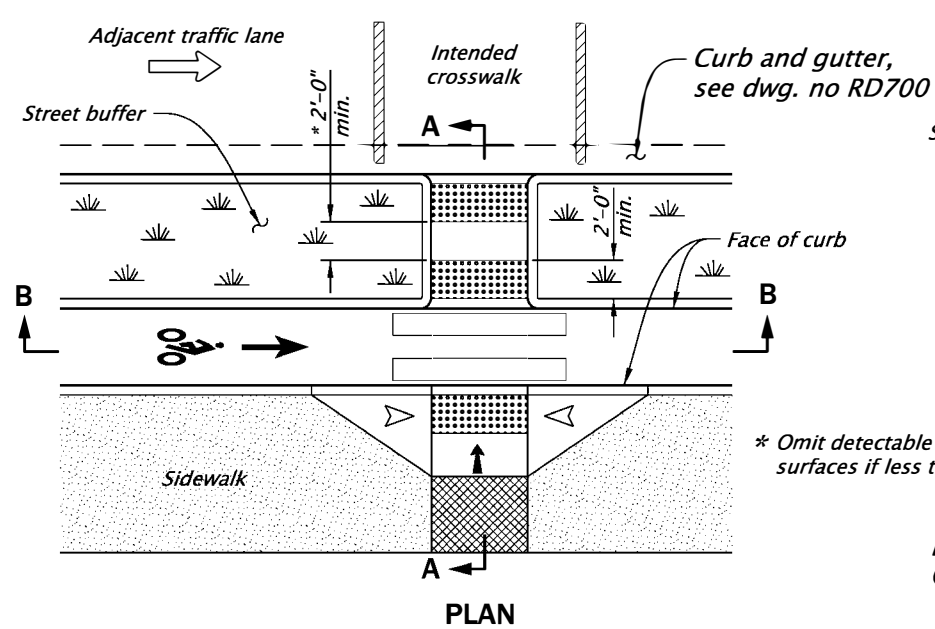
SECTION A-A

CONCRETE TRUCK WASH OUT FACILITY
NOT TO SCALE

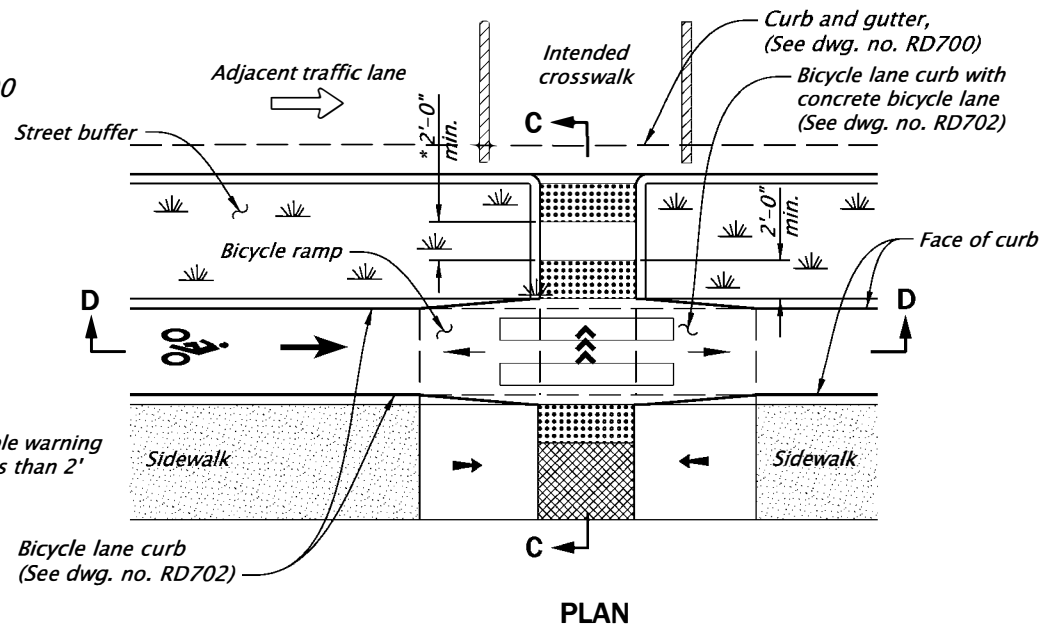
CALC. BOOK NO. <u>N/A</u>		SDR DATE <u>January, 2021</u>	
NOTE: All material and workmanship shall be in accordance with the current City of The Dalles Standard Specifications			
CITY OF THE DALLES STANDARD DRAWINGS			
CONCRETE TRUCK WASH OUT			
2025			
DATE	REVISION DESCRIPTION		
Jan 2021	Removed Calc book numbers		

The selection and use of this Standard Drawing, while designed in accordance with generally accepted engineering principles and practices, is the sole responsibility of the user and should not be used without consulting a Registered Professional Engineer.

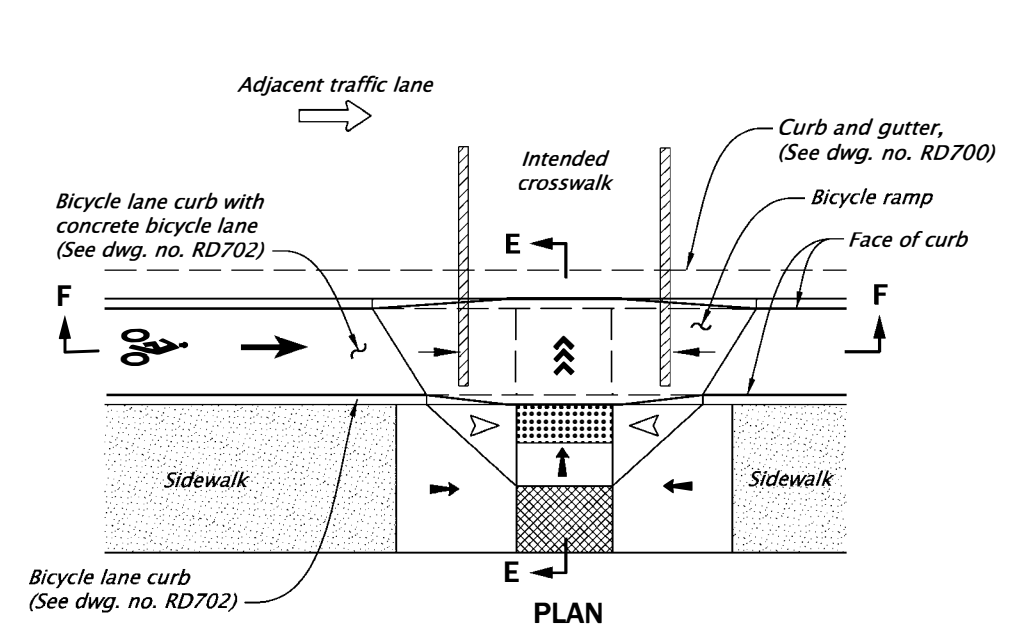
RD1070



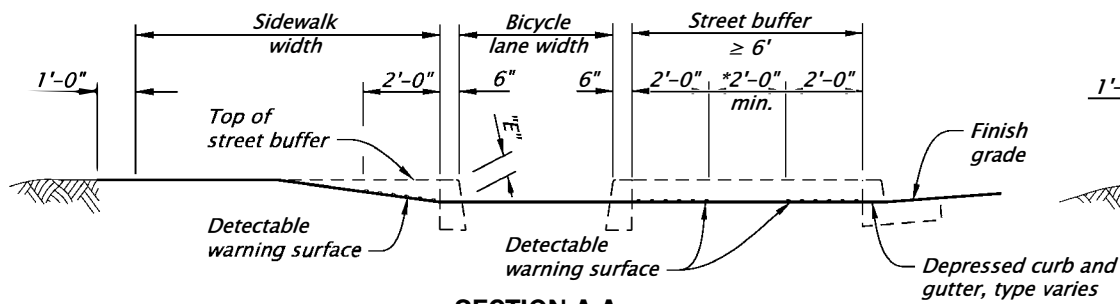
PLAN



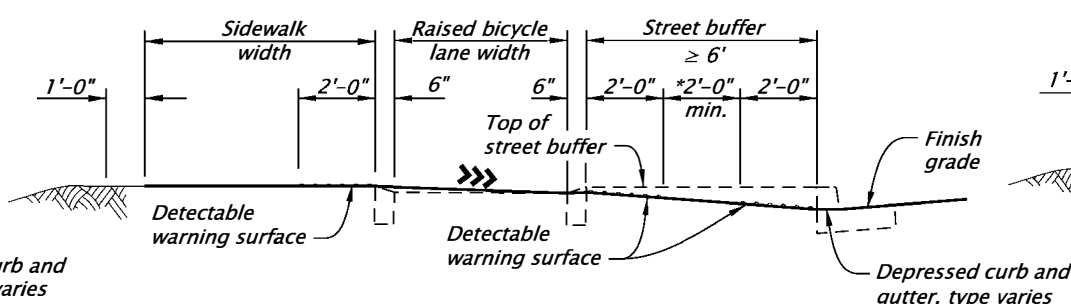
PLAN



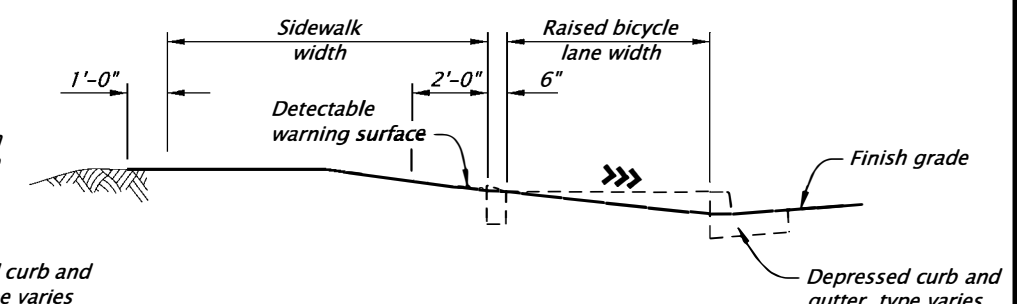
PLAN



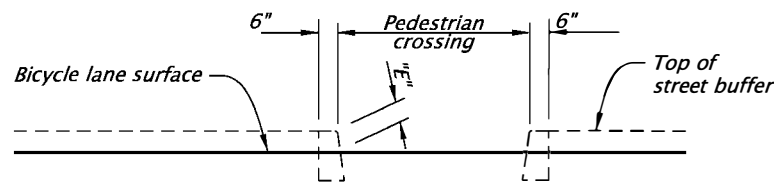
SECTION A-A
(Street buffer ≥ 6')



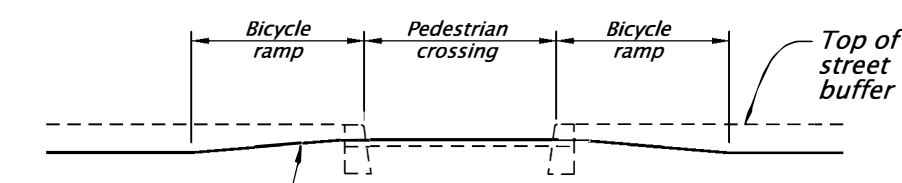
SECTION C-C
STREET BUFFER ≥ 6'



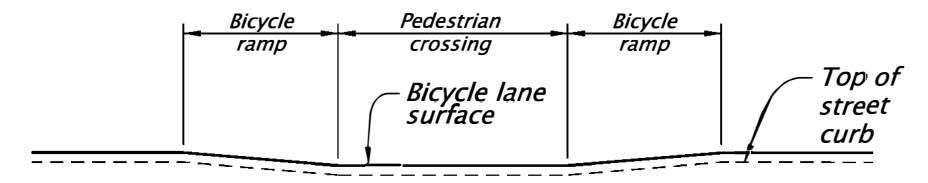
SECTION E-E



SECTION B-B



SECTION D-D



SECTION F-F

BICYCLE LANE WITH STREET BUFFER
(Perpendicular curb ramp shown)

RAISED BICYCLE LANE WITH STREET BUFFER
(Parallel curb ramp shown)

RAISED BICYCLE LANE WITH NO STREET BUFFER
(Combination curb ramp shown)

GENERAL NOTES FOR ALL DETAILS ON THIS SHEET:

1. Separated bicycle lane Crossing details are based on applicable COTD standard.
2. Site conditions normally require a project specific design. See project plans for details not shown.
3. See dwg. nos. RD700 and RD702 for curbs. See dwg. no. RD710 for accessible route island. See dwg. nos. TM503 and TM530 for crosswalk markings, widths, etc. See dwg. nos. RD902 through RD908 for detectable warning surface details.
4. Ramp slopes shown are relative to the true level horizon (zero bubble).
5. Lower bicycle lane curb at all curb ramp pedestrian crossings.
6. On separated bicycle lanes (where bicycle lane is apart from road shoulder), gutter pan shall not end in bicycle lane.
7. On or along state highways, where curb and gutter is required at curb ramps, add concrete bicycle lane to bicycle lane curb at curb ramps and at inlets.

LEGEND:

- Staggered continental crosswalk (1' white bars)
- Marked or intended crossing location
- Sidewalk or other traversable surface
- Detectable warning surface (DWS)
- Level area (turning space/landing)
- Running slope, 4.0% maximum (Maximum 4.9% finished surface slope)
- Running slope 7.5% maximum (Maximum 8.3% finished surface slope)
- Flare slope (Maximum 10.0% finished surface slope)

The selection and use of this Standard Drawing, while designed in accordance with generally accepted engineering principles and practices, is the sole responsibility of the user and should not be used without first consulting a Registered Professional Engineer.

All materials shall be in accordance with the current City of The Dalles Standard Specifications.			
CITY OF THE DALLES STANDARD DRAWINGS			
SEPARATED BIKE LANE CROSSING			
2025			
DATE	REVISION DESCRIPTION		
12-2021	NEW DRAWING CREATED		
CALC. BOOK NO.	N/A	SDR DATE	14-JAN-2022
			RD1140