



State of Oregon Department of Environmental Quality

Written Comments

Willamette Subbasin TMDL

This document is a compilation of written comments received during the public comment period for the Willamette Subbasins TMDL.

DEQ accepted public comment on the proposed rulemaking from Jan. 10, 2024, until 4 p.m. on March 15, 2024. DEQ extended the public comment period for 21 days at the request of the public.

DEQ held one public hearing on Feb. 16, 2024 at 9 a.m. DEQ received three comments at the hearing. Later sections of this document include a summary of the comments received during the open public comment period, DEQ's responses, and a list of the commenters. Original comments are on file with DEQ.

Translation or other formats

[Español](#) | [한국어](#) | [繁體中文](#) | [Русский](#) | [Tiếng Việt](#) | [العربية](#)

800-452-4011 | TTY: 711 | deqinfo@deq.oregon.gov

Non-discrimination statement

DEQ does not discriminate on the basis of race, color, national origin, disability, age or sex in administration of its programs or activities. Visit DEQ's [Civil Rights and Environmental Justice page](#).



United States Department of the Interior

BUREAU OF LAND MANAGEMENT
Northwest Oregon District Office
1717 Fabry Road SE, Salem, Oregon 97306
<http://www.blm.gov/or>



February 23, 2024

Michele Martin
Project Manager
Oregon Department of Environmental Quality
700 NE Multnomah St. Suite 600
Portland, OR 97232
Michelemartin@deq.state.or.us

Subject: Comments on Draft Water Quality Management Plan – Riparian Vegetation Management Strategies

Dear Michele,

The Bureau of Land Management (BLM) has thoroughly reviewed the draft requirements stipulated within the Willamette subbasins Draft Water Quality Management Plan, specifically those pertaining to riparian vegetation management strategies for streamside vegetation. While we appreciate DEQ's efforts to ensure the achievement of Total Maximum Daily Load (TMDL) load allocation and effective shade targets, we wish to address several points where our findings diverge, particularly concerning the management of intermittent, non-fish bearing streams (pg. 22 paragraph 1 & table 5).

1. Intermittent Streams and Temperature Contribution

We argue that intermittent streams, by their very nature, do not contribute to increased temperature during periods of potential non-attainment. These streams flow only during certain times of the year, primarily in response to precipitation or snowmelt, and thus, during dry periods or drought conditions, they do not flow at all. The concern for stream warming is primarily associated with continuous water flow, where prolonged exposure to sunlight can significantly raise water temperatures. In the case of intermittent streams, the absence of flow during critical warm periods negates the risk of contributing to temperature non-attainment areas. Therefore, the management strategies for these streams should reflect their distinct hydrological characteristics, acknowledging that their impact on overall water temperature and quality is significantly different from that of perennial streams.

2. Analogous Streams in Roon et al. (2021) Study

Secondly, the streams studied in Roon et al. (2021), which DEQ cites to support the management strategies, are not analogous to the headwater intermittent streams managed by BLM. The referenced study focuses on larger, fish-bearing perennial streams, which fundamentally differ in both ecological function and hydrological dynamics from intermittent streams. Perennial streams have continuous flow and support aquatic life year-round, which necessitates different management approaches to maintain temperature and habitat quality. The application of findings from perennial stream studies to intermittent stream management overlooks critical differences in stream ecology and hydrology, potentially leading to ineffective or inappropriate management prescriptions for intermittent streams.

Furthermore, it's crucial to note that the temperature signal measured in the Roon et al. (2021) study dissipated downstream within 75-200m. (fig. 5) This dissipation suggests that even if temperature increases were to occur due to thinning practices, their impact would be localized and transient, not affecting the broader stream ecosystem or the achievement of TMDL load allocation and effective shade targets over a significant distance.

3. Silvicultural Prescription and No-Cut Buffers

Lastly, the silvicultural prescription used in the study cited (Roon et al., 2021) is not directly transferable to the context of BLM's management practices, particularly due to our implementation of no-cut buffers along streams. The study's approach involved thinning vegetation up to the stream bank, a practice not permitted under BLM's management policies for streams within our jurisdiction. BLM maintains no-cut buffers (50 feet for intermittent, non fish-bearing), a critical measure to protect water quality and streamside habitat by preserving canopy cover and minimizing direct human impact to the riparian zone. This distinction is crucial as it underscores the differing potential for shade reduction and temperature increase. BLM's management practices are designed to maintain, if not enhance, effective shade and reduce the risk of stream warming, contrary to the implications of applying the study's findings to our context.

In light of these points, we respectfully request that DEQ reconsider the applicability of the draft requirements to intermittent, non-fish bearing streams managed by BLM. We believe that a nuanced understanding of the hydrological and ecological characteristics of these streams, along with a careful consideration of BLM's existing management practices, will lead to more effective and appropriate water quality management strategies.

BLM is committed to working collaboratively with DEQ to protect and improve water quality while ensuring that management strategies are based on sound science and reflect the specific conditions of the streams under our management. We are prepared to provide further information and engage in discussions to help ODEQ move forward towards a final Water Quality Management Plan that accurately addresses the unique aspects of intermittent stream management. The BLM is committed to protecting the water quality within the Willamette

Subbasins and ensuring adherence to water quality standards. The BLM will continue our work to educate the public about the vital significance of these lands and the critical need to preserve their environmental integrity. We look forward to your response and the opportunity to continue our collaborative efforts towards sustainable water quality management and the BLM requests the opportunity to work with ODEQ staff to resolve this issue.

DENNIS TEITZEL
Dennis C. Teitzel,
District Manager, Northwest Oregon District,
1717 Fabry Rd SE, Salem, OR 97306

Digitally signed by DENNIS
TEITZEL
Date: 2024.02.23 07:21:12 -08'00'



Department of Energy

Bonneville Power Administration
P.O. Box 3621
Portland, Oregon 97208-3621

POWER SERVICES

March 15, 2024

In reply refer to: PGA-5

Comment submitted via email: Willamette.TemperatureTMDL@DEQ.oregon.gov

Ms. Michele Martin
Oregon DEQ, Water Quality Division
700 NE Multnomah St #600
Portland, OR 97232

Subject: Comments to the Oregon Department of Environmental Quality on Draft Willamette Subbasins Total Maximum Daily Loads for Temperature.

Dear Ms. Martin:

The Bonneville Power Administration (Bonneville) appreciates the opportunity to provide comments on the Oregon Department of Environmental Quality's (ODEQ) draft Willamette Subbasins Temperature Total Maximum Daily Loads (TMDL). The draft TMDL and associated draft Water Quality Management Plan (WQMP) place implementation requirements for temperature management of the U.S. Army Corps of Engineers' Willamette Valley System (WVS) dams.

Bonneville markets and distributes the hydropower generated at thirty-one Federal Columbia River Power System hydroelectric projects, including eight U.S. Army Corps of Engineers dams in the WVS. Bonneville, as part of the U.S. Department of Energy, operates as a not-for-profit federal entity, selling cost-based electrical power and transmission services to benefit the Pacific Northwest, especially the public bodies and cooperatives that serve domestic and rural consumers. In providing these services, Bonneville must balance multiple public duties and purposes, including: assuring the Pacific Northwest has an adequate, efficient, economical, and reliable power supply; promoting energy conservation and the use of renewable resources; and, acting consistent with the program developed by the Northwest Power and Conservation Council by protecting, mitigating, and enhancing fish and wildlife in the Columbia River basin that are affected by the development and operations of the federal facilities from which Bonneville markets power.¹

¹ 16 U.S.C. § 839. Unlike most federal agencies, Bonneville does not receive annual congressional appropriations; instead, the agency is self-financed from revenues received from the sale of power and transmission services. Bonneville utilizes this revenue to not only pay for the continuing costs associated with its programs (including power, transmission, and fish and wildlife actions) but also to repay the United States Treasury for the power share of the original federal investment used to construct the Federal Columbia River Power System. The Bonneville Administrator must operate the agency in a manner that allows it to recover its costs "in accordance with sound

The U.S. Army Corps of Engineers (Corps) operates and maintains thirteen WVS dams for multiple congressionally authorized purposes including flood risk management, hydropower generation, water quality, irrigation, navigation, recreation, water supply, and fish and wildlife benefits. While the Corps is congressionally authorized to operate the WVS dams for multiple purposes, Bonneville is the federal agency Congress authorized to market and distribute the power generated at eight dams in the WVS. In return, Bonneville is required to pay, either directly to the Corps, or as a reimbursement to the U.S. Treasury, (1) all costs associated with power-specific operations and assets (e.g. turbines); and (2) a share of “joint costs,” which benefit or mitigate, for all purposes of the facility (e.g. fish mitigation, water quality). Any additional costs applied to the hydropower facilities in the WVS as a result of TMDL implementation will increase Bonneville’s costs, which in turn will impact Bonneville ratepayers throughout the Northwest.

Bonneville’s comments pertain to the following documents provided by ODEQ:

- Draft Willamette Subbasins Total Maximum Daily Loads for Temperature (TMDL)
- Draft Willamette Subbasins TMDL Technical Support Document (TMDL TSD)
- Draft Willamette Subbasins Water Quality Management Plan (WQMP)

Bonneville’s comments focus on dam and reservoir operations’ load allocation, flexibility for TMDL implementation, and reporting:

1. Nonpoint source Human Use Allowance allocation and Minimum Duties provision

The TMDL allocates 0.00°C to dam and reservoir operations but provides upward of 0.05°C to water management activities and water withdrawals and 0.02°C to solar loading from existing transportation corridors, existing buildings, and existing utility infrastructure. In Section 9.1.4.1, the TMDL seems to imply that the minimum duties provision in OAR 340-042-0028(12)(a)² is justification for the 0.00°C allocation, stating, “For dam and reservoir operations, the minimum duties provision is implemented when 7DADM temperatures upstream of the reservoirs exceed the applicable temperature criteria, the dam and reservoir operations must not contribute any additional warming above and beyond those upstream temperatures entering the reservoir.” However, the TMDL does not explain how the minimum duties provision is not also applicable to the other nonpoint anthropogenic sources that received a portion of the human use allowance.

Dam and reservoir operations should receive a portion of the human use allowance allocation. Bonneville requests that ODEQ describe why this sector was not given a

business principles.”

16 U.S.C. § 839e(a)(1). This includes the objectives of setting the lowest possible rates for Bonneville services, while enabling Bonneville to make timely repayments to the United States Treasury and simultaneously fulfilling multiple public purposes for the benefit of the Pacific Northwest.

² Bonneville notes the TMDL incorrectly cites to OAR 340-042-0028(12)(a) while it should be citing to OAR 340-041-0028(12)(a).

portion of the allocation and in the revised TMDL, provide the rationale for why dam and reservoir operations received its load allocation.

2. **Generalization of water temperature control**

Bonneville also requests ODEQ become familiar with WVS operations because the application of the temperature water quality criteria is oversimplified and not aligned with the WVS's obligation to operate the dams to protect ESA-listed fish. The TMDL TSD Section 7.2 states, "Management and operation of dams and reservoirs to minimize temperature warming," which does not consider important factors such as seasonally appropriate dam releases conducted to improve habitat for ESA-listed fish under the existing National Marine Fisheries Service Biological Opinion. An additional example is the strategic release of warm water that occurs at Cougar Dam and Detroit Dam during the warm season for the benefit of fall water temperatures.

3. **Implementation for controlling reservoir water temperature and flexibility for dam and reservoir operators**

The WQMP Section 5.3.5 states that large dam owners, including the Corps as identified in Table 6, "...develop TMDL implementation plans that include reservoir-specific management strategies to mitigate temperature increases that happen between the inflow and outlet of the dam." As discussed, these general statements do not account for the WVS dams' operational constraints due to their congressionally authorized purposes and further constrained by court order and Endangered Species Act-related operational requirements. There is little, if any, margin remaining for altering operations to address water temperature. Bonneville requests that the WQMP acknowledge constraints of large dam owners that impact their ability to implement measures to achieve their load allocation in compliance with other laws. TMDL implementation should include flexibility by allowing implementation activities that do not focus on operational changes.

4. **Implementation reporting requirements**

ODEQ should allow for alignment of reporting requirements with the Corps' requirements for the 2008 Biological Opinion issued by the National Marine Fisheries Service and the U.S. Fish and Wildlife Service, and any future Biological Opinions. Allowing reporting that is consistent with the Corps' currently (or future) required reporting will create a streamlined process, which will help to reduce additional administrative burdens.

5. **Correction to TMDL and TMDL TSD**

In the TMDL TSD under Section 9.3.1 Dam and reservoir operations (pg. 109) the "minimum duties provision" reference to OAR 340-042-0028(12)(a) should be changed to OAR 340-041-0028(12)(a). The same correction should be made in the TMDL under Section 9.1.4.1 Dam and reservoir operations (pg. 45).

Bonneville appreciates the opportunity to provide comments on ODEQ's draft Willamette Subbasins Temperature TMDL and related documents to ensure that any new requirements are reasonable, purposeful, implementable, practicable, and cost effective. This is especially important to Bonneville because the draft TMDL and WQMP conditions would further impact Bonneville's costs, and thus, the region's ratepayers. We welcome the opportunity to discuss our comments with ODEQ. Please contact me if you have any questions on these comments.

Sincerely,

**MICHELLE
CATHCART**

 Digitally signed by MICHELLE
CATHCART
Date: 2024.03.15 11:36:30 -07'00'

Michelle Cathcart
Vice President of Generation Asset Management
Bonneville Power Administration



*Working with community wastewater treatment and stormwater management agencies
across the state to protect Oregon's water quality since 1987.*

81 East 14th Avenue
Eugene, Oregon 97401
(541) 485-0165 www.oracwa.org

March 1, 2024

Michele Martin
DEQ Water Quality Division
700 NE Multnomah Street, Suite 600
Portland, Oregon 97232-4100

Sent via email to: Willamette.TemperatureTMDL@DEQ.oregon.gov

Subject: Comments on the Draft Willamette Subbasins Temperature TMDL

Dear Michele Martin:

Thank you for the opportunity to provide comments on the Willamette Subbasins Temperature TMDL. These comments are provided on behalf of ACWA, which is a not-for-profit organization of Oregon's wastewater treatment and stormwater management utilities, along with associated professional consulting firms, which are dedicated to protecting and enhancing Oregon's water quality. Our members provide wastewater and stormwater services to over 3 million Oregonians, serving over 75% of Oregon's homes and businesses.

Susie Smith, who was ACWA's previous Executive Director, represented municipalities on DEQ's Rules Advisory Committee (RAC). In April 2023, ACWA provided extensive comments on a preliminary version of the Willamette Subbasins TMDL during the RAC process. It is not entirely clear how DEQ addressed these comments in preparing the draft TMDL for public comment. As such, we find ourselves reiterating many of previous comments that we had made earlier in the process, which calls into question the value of the RAC process in identifying and addressing issues early in the TMDL development process.

Going forward, ACWA appreciates being involved in the RAC process for TMDL development and hopes for more opportunities for open discussion with DEQ in the future. ACWA also requests that future RACs not only include a representative of Oregon cities but also Oregon counties. Finally, ACWA is hopeful that the RAC process include discussion of comments between RAC representatives and DEQ and allow time to develop comment letters responding to DEQ's decisions.

We fully recognize that DEQ is under a court ordered time schedule for the series of replacement TMDLs. However, we also recognize that the methods and approaches DEQ staff has applied to

developing the draft Willamette Subbasins TMDL will likely be replicated elsewhere in the state, and that getting these TMDLs right is as important as getting them done on time. Recognizing the importance of this TMDL, the ACWA TMDL Work Group, which is made up professionals from numerous wastewater and stormwater agencies in the Willamette Basin, have dedicated significant time and effort in reviewing, discussing, and providing their questions and concerns about the draft TMDL and WQMP documents. Comments are provided below and are organized by the sections of the Willamette Subbasins TMDL and Water Quality Management Plan.

DRAFT TOTAL MAXIMUM DAILY LOADS FOR THE WILLAMETTE SUBBASINS

Section 2. TMDL Name and Location

The scope of the Willamette Subbasins TMDL includes the upper portions of the North Santiam, South Santiam, Clackamas, Long Tom Middle Fork Willamette, and Coast Fork Willamette Rivers. It also includes the entire length of the McKenzie River, Molalla-Pudding Rivers, and smaller tributaries to the upper, middle and lower Willamette River. The scope of the waterbodies that are included in the TMDL is very confusing. There is no discussion as to why DEQ chose to delineate the scope of the Willamette Subbasins in this manner. DEQ is asked to provide its thought process in delineating the scope of the Willamette Subbasins TMDL.

Furthermore, it is not clear how DEQ plans to link the Willamette Subbasins TMDL with the Willamette Mainstem TMDL project that is currently getting underway. DEQ should articulate how they plan to integrate the Willamette Subbasins TMDL with the Willamette Mainstem TMDL and provide the framework for the entire Willamette Basin TMDL.

Additionally, clarification is needed regarding the applicability of this TMDL to the Willamette Subbasins and how nonpoint sources are anticipated to either be covered by the Willamette Subbasin TMDL or Willamette Mainstem TMDL. For example:

- The draft TMDL document (Table 2-2) states that the mainstem Willamette River is not addressed by the Willamette Subbasins temperature TMDLs “*from the confluence of the Columbia River upstream to the confluence of Coast Fork of the Willamette and Middle Fork of the Willamette Rivers*”. However, it is not clear whether that statement applies to both point and nonpoint sources.
- In the nonpoint section of the draft TMDL WQMP, it appears that all areas of a jurisdiction draining to the Willamette River are covered by the Willamette Subbasin TMDL. DMA areas in Appendix A do not appear to exclude areas that drain directly to the mainstem Willamette River without first draining to a tributary.
- The online map, ownership and jurisdictional boundaries do not appear to exclude areas draining directly to the main stem.

ACWA requests that DEQ align maps and jurisdictional DMA areas with intended coverage of the TMDL for clarity and consistency.

Section 5. Seasonal Variation and Critical Period for Temperature

This section includes a paragraph that describes the critical period for the various waterbodies included in the Willamette Subbasins TMDL. We recommend that DEQ include a tabular summary of the waterbodies and their associated critical periods so that they are readily apparent.

Section 7. Pollutant Sources or Source Categories

Section 7.1 identifies the point source discharges in the Willamette Subbasins that are the subject of the TMDL. They are divided into three categories including individual NPDES permitted point sources (Table 7.1), individual NPDES Municipal Separate Storm Sewer System (MS4) permittees (Table 7.2), and general NPDES registrants (Table 7.3). Our comments on Section 7.1 are organized accordingly.

Individual NPDES Permits:

The title of Table 7-1 should be changed.

Table 7-1 is titled “Individual NPDES permitted point source discharges that contribute thermal loads to Willamette Subbasins streams at a frequency and magnitude to cause exceedances to the temperature standard.” Many of the sources listed in the table are minor and likely have little or no impact on temperature. Additionally, there are several sources listed in the table for which DEQ did not provide an allocation because they do not discharge during the TMDL period (see Table 9-11), and as such, do not contribute thermal loads *at a frequency and magnitude to cause exceedances to the temperature standard* as stated by the title of Table 7-1. Thus, the title of Table 7-1 is misleading. This table is merely a listing of the individual point sources in the geographic area covered by the TMDL. The title of the table should be revised to state “Individual NPDES permitted point source discharges to Willamette Subbasins streams.”

Municipal Stormwater (MS4) Permits:

DEQ should clarify the findings on thermal load potential contributions from MS4s.

This section identifies MS4 permits “as potential sources of thermal load” and notes that “there is not sufficient evidence to demonstrate” that MS4, 1200-C and 1200-Z discharges contribute to exceedances of the temperature standard. DEQ should make a clear, definitive statement on this issue, such as the following:

“Based on a review of published literature and other studies related to stormwater runoff and stream temperature in Oregon, DEQ ~~found there is not sufficient evidence to demonstrate~~ concluded that stormwater discharges authorized under the current municipal (MS4s) permits or the construction (1200-C) and industrial (1200-A and 1200-Z) general stormwater permits do not contribute to exceedances of the temperature standard. Therefore, wasteload allocations for these sources are not included in the TMDL.”

General Permits:

The title of Table 7-3 should be changed.

This section of the TMDL lists several categories of general NPDES Permits and identifies three general NPDES permit categories (i.e., 100-J (non-contact cooling water), 200-J (filter backwash), and 300-J (fish hatcheries)) as “potential significant sources of thermal load with a temperature impact.” Table 7-3 is titled “General NPDES permit registrants that contribute thermal loads to Willamette Subbasins streams at a frequency or magnitude that contributes to exceedances of the temperature standard.”

Again, the title of the table is misleading. Many of the sources listed in the table are minor and likely have no impact on temperature. This table lists the registrants of the three general permit categories that DEQ has determined “have the potential to discharge thermal loads...”. The title of the table should be

revised to state “Registrants in the General NPDES Permit categories that have the potential to contribute thermal loads to Willamette Subbasins.”

Section 9. Allocations, Reserve Capacity, and Margin of Safety

Section 9 describes the methods and considerations for allocating allowable pollutant loads across point sources, nonpoint sources, margin of safety and reserve capacity. This section includes the following:

“OAR 304-042-0040(5) and (6) describe the potential factors of consideration for determining and distributing these allocations of the allowable pollutant loading capacities...Factors to consider in allocation distribution may include: source contributions; costs of implementing management measures; ease of implementation; timelines for attaining water quality standards; environmental impacts of allocations; unintended consequences; reasonable assurance of implementation; and any other relevant factor.”

As currently crafted, the draft TMDL documents appear to be based on modeling and mathematical analysis, without consideration of the factors cited above. The basis or reasoning for allocations to the source categories is not explained in the TMDL, nor is there an analysis of the allocations with respect to these factors. ***From this TMDL will come permit requirements that must be met and compliance measures that must be implemented.*** The considerations noted above must be considered with due diligence in the development of this TMDL and WQMP in order to create a realistic framework for achieving the temperature targets. ***That means that permit and TMDL implementation plan requirements must be feasible, implementable, cost-effective, and within the resource capacity of permittees and DMAs.***

Our comments regarding DEQ’s source category allocations directly relate to the factors listed above. DEQ needs to re-evaluate its recommended allocations through the lens of all the factors of consideration included in OAR 304-042-0040 (5) and (6) and provide greater clarity and transparency as to its conclusions. Our comments below should alert the Department to significant issues related to costs of implementation, unintended consequences, negative environmental impacts of allocations, and lack of reasonable assurance of implementation. All of these will have a ripple effect impacting the attainment of water quality standards.

Allocation of the Human Use Allowance

DEQ must provide justification and reasoning for its source category allocation of the Human Use Allowance (HUA). The HUAs included in the draft TMDL documents vary across subbasins and have been changed since the 2006 TMDL without substantiation. Where science and fact-based information do not justify a change in HUA allocations, the 2006 allocations should be retained.

Section 9.1 of the TMDL document specifies the sector specific allocations for the HUA. Other than a statement that the “assigned portion of the human use allowance represents the maximum cumulative warming anywhere in the waterbody and at the point of maximum impact from all nonpoint source activities within each source category”, there is no explanation for the allocation of the HUA in the Willamette Subbasins TMDL document. For example, the 0.2 deg C is allocated to point sources in the Molalla-Pudding (Table 9-1) and the Clackamas Subbasins (Table 9-2) whereas 0.15 deg C is allocated to point sources in the Upper, Middle and Lower Willamette Subbasins (Tables 9-3, 9-4, and 9-5). There

is no explanation provided for the different allocations in the draft TMDL document. The tables below illustrate the differences in sector-specific HUAs that should be explained in the TMDL.

Table 9-1: Human use allowance allocations on the Molalla River, Pudding River, Silver Creek, Abiqua Creek, and Mill Creek (Molalla-Pudding Subbasin).

Portion of Human Use Allowance (°C)	Source or source category
0.20*	NPDES point sources
0.00	Dam and reservoir operations
0.05	Water management activities and water withdrawals
0.02	Solar loading from existing transportation corridors, existing buildings, and existing utility infrastructure
0.00	Solar loading from other nonpoint sectors
0.03	Reserve capacity
0.30	Total
<p><i>Note:</i> * NPDES permitted point sources are allowed up to 0.20°C cumulatively at the point of maximum impact on the Molalla River, Pudding River, Silver Creek, Abiqua Creek, and Mill Creek. The portion of the human use allowance assigned to each point source at the point of discharge is described in Table 9-11.</p>	

Table 9-3: Human use allowance allocations on Amazon Creek, Calapooia River, Camas Swale Creek, and Marys River (Upper Willamette Subbasin).

Portion of Human Use Allowance (°C)	Source or source category
0.15*	NPDES point sources
0.00	Dam and reservoir operations
0.05	Water management activities and water withdrawals
0.02	Solar loading from existing transportation corridors, existing buildings, and existing utility infrastructure
0.00	Solar loading from other NPS sectors
0.08	Reserve capacity
0.30	Total
<p><i>Note:</i> * NPDES permitted point sources are allowed up to 0.15°C cumulatively at the point of maximum impact on Amazon Creek, Calapooia River, Camas Swale Creek, and Marys River. The portion of the human use allowance at the point of discharge is described in Table 9-11.</p>	

Table 9-4: Human use allowance allocations on the Columbia Slough and Mount Scott Creek (Lower Willamette Subbasin).

Portion of Human Use Allowance (°C)	Source or source category
0.15*	NPDES point sources
0.00	Dam and reservoir operations
0.05	Water management activities and water withdrawals
0.02	Solar loading from existing transportation corridors, existing buildings, and existing utility infrastructure
0.00	Solar loading from other NPS sectors
0.08	Reserve capacity
0.30	Total
<p><i>Note:</i> * NPDES permitted point sources are allowed up to 0.15°C cumulatively at the point of maximum impact on the Columbia Slough and Mount Scott Creek. The portion of the human use allowance at the point of discharge is described in Table 9-11.</p>	

The above tables illustrate the differences in the NPDES point source allocations. DEQ should provide an explanation for these differences.

The HUA allocation for non-point sources of 0.0° C is not defensible based on real world constraints.

Please explain why the sector-specific allocations do not include an allocation for solar loading from non-point sources (other than existing transportation and utility infrastructure). There is no justification provided in the documents, nor is there an explanation of why the allocation of 0.0° C is a justified change from the 0.05° C allocation included in the 2006 TMDL. If there is no allocation for non-point sources, that would mean that achieving the TMDL target requires fully vegetated stream corridors at maximum effective shade. Factual, on-the-ground constraints, established laws, and competing environmental needs in some areas to retain solar access, make this aspirational goal unachievable. TMDL policy implications of a 0.0° C HUA for solar loading from other NPS sectors would set DMAs up for failure, because it would require implementation of shading activities that are beyond local governments' authorities. Moreover, setting an unachievable goal in a specific sector would mean that DEQ has not established an achievable path to meet its TMDL targets. Examples of some of the constraints were provided by the City of Gresham and is attached at the end of this document.

- Cities and counties are limited in their scope of control over private property in their jurisdictions and they cannot legally compel private property owners to plant and retain trees absent a proposed land use action. Local governments implement riparian buffer protection and restoration requirements through development codes and ordinances in a manner consistent with Statewide Land Use Goal 5—Natural Resources. The Oregon Administrative Rules (OAR) governing inventorying and protection of riparian corridors are found in OAR 660-023-0090. These rules require that local jurisdictions inventory riparian corridors and either adopt riparian buffer widths and protections based on “safe harbor” provisions or that they establish alternative buffers based on science-based evaluations. Riparian protection ordinances legally cannot, independent of a land use action, compel private property owners to plant and maintain trees or conduct water quality monitoring. These codes and ordinances are triggered when development applications are submitted, and sometimes when building permit applications are submitted. In these cases, local jurisdictions can require riparian restoration activities within certain legal tests that require proportionality with the land use action.

Even when riparian buffers are established and trees can be required on private properties, regulatory buffer widths are subject to site constraints, existing structures, established land use laws and regulations, and property owner rights to develop their sites consistent with zoning and land use designations. For reference, OAR 0660-023-0090 sets safe harbor riparian protection areas at 75' from top of bank for streams larger than 1,000 cfs, and at 50' from top of bank for streams smaller than 1,000 cfs. It should be anticipated that in most cases local jurisdictions have very limited ability to require or incentivize private property owners to provide a 120-foot or other defined riparian buffer width.

- An additional constraint in the context of private property rights is the fact that if a voluntary transaction is not possible, condemnation would be the next requirement of a city, county or special district to enable tree planting on someone else's property. The condemnation process is expensive and time consuming. Many city councils and boards may find the practical and political downsides of condemning, for instance, portions of a farmer's property untenable.

- Certain riparian areas have inventoried significant natural resources, including wetlands and sensitive/endangered/threatened species of plants and animals that require retention of sunlight to maintain habitat conditions and ecological regimes necessary to sustain plant species. For example, areas that are protected for Western Pond turtle habitat, which exist within DMA jurisdictional boundaries, must be exposed to the sun. The Temperature TMDL should incorporate the need to maintain these types of areas for multi-objective environmental benefits, including natural and constructed wetlands and other protected habitat areas, for Endangered Species Act considerations. In some of these cases, planting trees is inconsistent with maintaining habitat conditions.
- Some DMAs have overlapping jurisdiction with other local government entities and cannot compel tree planting in areas that impact other jurisdictions' functions. For example, some cities have drainage districts established within their jurisdictional boundaries. Like power utilities (that are given an HUA greater than zero in the draft TMDL), drainage districts must restrict tree planting in certain areas, and in some cases remove trees to maintain their facilities. The cities (or counties) cannot be obligated to achieve effective shade where drainage districts or other similar special districts operate drainage and flood control facilities that must be free and clear of vegetation. Even where a DMA has constructive control such that it can respond to stream temperatures, the requirements to do so are vaguely written and somewhat confusing. DEQ needs to clarify how a DMA can achieve the temperature target.
- Another example of where shade targets need to account for land use constraints is the Port of Portland. The TMDL specifies that effective shade be increased by 16%. A large portion of the Port's property is dedicated to aviation use. These properties have significant constraints stemming from aviation rules and regulations related to vegetation.
- Other state agency objectives, such as those implemented through measures that compel cities to allow increased urban density (which have been enacted to increase affordable housing) or that compel tree removal in certain areas (to protect certain areas against wildfire risk), also constrain cities abilities to achieve effective shade targets.
- Existing structures, and the development of new water related and/or water dependent uses are allowed by state land use laws, including rules that implement Statewide Land Use Goal 5, subject to reasonable approval processes. Local governments cannot place a blanket ban on these uses for the purposes of increasing effective shade.

While there may well be significant additional potential for local governments to increase effective riparian shade, the measures they can take are limited, and the constraints to achieving DEQ's aspirational shade goal are very real. DEQ needs to factor in some reasonable non-point source HUA to recognize these constraints. We recommend that DEQ include a similar allowance for non-point sources as provided for the "transportation corridor, buildings and existing infrastructure" (0.02° C). Including an allocation for non-point sources recognizes both the dynamic nature of streamside vegetation and the limitations that Designated Management Agencies (DMAs) have in achieving TMDL goals.

Assigning a zero allocation for non-point sources may have unintended consequences related to point source discharges.

The zero allocation for non-point sources may mean that point sources will not be able to utilize water quality trading as a compliance strategy. That would negatively impact DEQ’s ability to achieve the TMDL target over time and would likely lead to public expenditure of funds for unsustainable mechanical cooling infrastructure that provides little to no benefit to the river or fish habitat, and runs counter to the State’s climate protection/carbon reduction goals. The permit compliance strategy implications for point sources need to be more fully evaluated, and the allocation should be not set such that it would eliminate opportunities for wastewater utilities to invest in riparian shade enhancement projects. As stated above, DEQ should adjust the sector-specific human use allocations to provide an allocation for solar loading from other non-point sources. A non-point source allocation as recommended above would enable point sources to pursue a water quality trading program as a compliance strategy. DEQ also should include a specific discussion of the water quality trading framework in the TMDL documents.

Thermal Wasteload Allocation for Point Sources

Section 9.1.2 states that “The wasteload allocation for registrants under the general stormwater permits (MS4, 1200-A, 1200-C and 1200-Z) and general permit registrants not identified in Table 9-11 is equal to any existing thermal load authorized under the current permit. More specific wasteload allocations can be considered if subsequent data and evaluation demonstrates a need and if capacity is available.” With regards to the stormwater permits (MS4, 1200-A, 1200-C and 1200-Z), this statement conflicts with the findings in Section 7.1 of the TMDL, which states that “there is not sufficient evidence to demonstrate that stormwater discharges authorized under the current municipal (MS4s) permits or the construction (1200-C) and industrial (1200-A and 1200-Z) general stormwater permits contribute to exceedances of the temperature standard.” Additionally, the TMDL includes wasteload allocations for general permit registrants (i.e., 100-J, 200-J, and 300-J) that have the potential to cause/ contribute to temperature exceedances. Therefore, ACWA recommends that the referenced statements in the first paragraph of Section 9.1.2 be deleted.

Table 9-11 presents the thermal wasteload allocation for point sources. The table specifies the allocated HUA, the TMDL period, and the minimum wasteload allocation for each source. We have several comments regarding this table.

Minimum Wasteload Allocations

The draft TMDL presents the minimum wasteload allocation. For facilities where multiple criteria apply during the TMDL period (i.e., spawning, core cold water, rearing/migration), DEQ should include wasteload allocations for the different periods. This information is essential in assessing compliance strategies. A snip from the 2006 Willamette TMDL provided below illustrates this point.

Table 4.15 Individual waste load allocations for low streamflow conditions.

Receiving Stream	River Mile	Point Source	Summer 7Q10 WLA (Million Kcal/day)	Spawning 7Q10 WLA (Million Kcal/day)
Clackamas River	22.6	ODFW Clackamas River Hatchery	51	49
Coast Fork Willamette River	21.5	Cottage Grove WWTP	11	21
McKenzie River	1.0	Weyerhaeuser Springfield	1071	744
North Santiam River	14.9	Stayton WWTP	57	89
Santiam River	9.3	Jefferson WWTP	7	12
South Santiam River	15.9	Lebanon WWTP	65	111
South Santiam River	31.5	Sweet Home WWTP	31	55

The above table provides an example of wasteload allocations that would apply during the spawning and rearing periods. In situations where multiple criteria apply, DEQ should include wasteload allocations for each use period.

Non-discharge Periods in NPDES Permits

DEQ should ensure that the “non-discharge” period in NPDES Permits for the facilities that were not given a wasteload allocation matches the TMDL time period.

The table below identifies municipal treatment facilities that were assigned a wasteload allocation of “zero” in Table 9-11.

Facilities with zero allocation	
Facility	Allocation Period
Aumsville STP	May - Oct
Aurora STP	May - Oct
Brownsville STP	May - Oct
Falls City STP	May - Oct
Gervais STP	May - Oct
Halsey STP	May - Oct
Junction City STP	May - Oct
Mt. Angel STP	May - Oct
Philomath WWTP	May - Oct
Sandy WWTP	May - Oct
Scio STP	May - Nov
Tangent STP	May - Oct
Timberlake STP	May - Oct

Presumably, these are for facilities that do not discharge to surface waters during the TMDL period. DEQ should verify that the non-discharge period for these facilities matches the TMDL period. For example, the Scio STP has a zero allocation and the TMDL period is defined as May 1 to November 30. The TMDL period is longer than the typical non-discharge periods specified in NPDES permits. DEQ should include an allocation for the facility if the TMDL period is longer than the non-discharge period in the NPDES permit.

The TMDL should include provisions for facilities that do not discharge during the dry season but may be compelled to discharge to surface waters under significant rain events that preclude land application or storage.

Municipal wastewater treatment facilities that do not discharge during the dry season tend to either store treated wastewater and/or land apply treated water for beneficial use. These activities are weather dependent. For example, a facility that irrigates during the dry season may not be able to land apply recycled water during a very wet spring and may have to continue surface discharge. Moreover, a facility may need to discharge in October with the onset of fall rains if there is no storage capacity or demand for irrigation. Surface water discharges during wet weather driven periods have little influence on temperature regimes and DEQ has authorized such weather-driven discharges when circumstances warrant. The TMDL should include a note that authorizes weather-driven discharges during the TMDL period for facilities that do not have a specific wasteload allocation.

Wasteload Allocations for Municipal Treatment Facilities

The table below includes the human use allowance, effluent flows, river flows and wasteload allocation from Table 9-11 and calculates the target effluent temperatures based on the applicable temperature criteria. This evaluation suggests that there are several municipal facilities that would have effluent temperature targets that are below 20C.

NPDES Permittee	Allocated HUA (deg C)	7Q10 Stream Flow (cfs)	Effluent Flow (cfs)	Min WLA (kcal/day)	Allowable ΔT (deg C)	Allocation Period	Allowable Effluent Temp ¹
City of Creswell	0.075	0	0.31	57,000	0.08	May	18.1
City of Coburg	0.075	0	0.68	125,000	0.08	May - Oct	18.1
City of Dallas STP ²	0.075	4.2	3.09	1,339,000	0.18	June - Sep	23.0
						May & Oct	18.2
City of Hubbard	0.2	2.39	0.35	1,338,000	1.56	May - Oct	19.6
City of Molalla	0.1	55.8	3.46	14,498,000	1.71	May - Oct	19.7
City of Silverton	0.2	14	3.87	8,743,000	0.92	May - Oct	18.9
City of Veneta	0.075	6.3	0.81	1,305,000	0.66	May & Oct	18.7
WES - Boring STP ³	0.075	0.65	0.03	125,000	1.70	June 16 - Oct 14	17.7
						Oct 15 - June 15	14.7
City of Woodburn STP	0.2	6.7	7.79	7,092,000	0.37	May - Oct	18.4

¹Rearing and migration criteria of 18C used except as noted below
²Cool water criteria of 22.8 C from June to Oct; the 18C rearing criteria applies in May and October
³Core cold water criteria from June 16 to October 14; spawning criteria from October 15 to June 15

For example, the draft TMDL includes a wasteload allocation of 0.057 million kcal/day for the City of Creswell; this allocation is substantially lower than the current NPDES permit limits which are based on the 2006 Willamette TMDL. The current NPDES permit for Creswell includes a static limit of 4.9 million kcal/day and an option for calculation of flow-based limits. An assessment of thermal loads from the treatment facility shows that the facility would be in immediate non-compliance with the proposed wasteload allocation in the TMDL. See attached temperature data from Creswell. Since there is reserve capacity available (Table 9-3), DEQ should utilize the reserve capacity and provide an achievable allocation for Creswell.

The draft TMDL includes a wasteload allocation of 0.125 million kcal/day for the Water Environment Services (WES) Boring STP. This allocation is substantially lower than the current NPDES permit limits which are based on the 2006 Willamette TMDL. The current NPDES permit for the WES Boring STP specifies wasteload allocations of 0.333 million kcal/day from June 16 – October 14 based on the core cold water criteria and 0.357 million kcal/day from October 15 – June 15 based on spawning use. An assessment of thermal loads from the treatment facility shows that the facility would be in immediate non-compliance with the proposed wasteload allocation in the TMDL. Since there is considerable reserve capacity available (Table 9-10), DEQ should utilize the reserve capacity and provide an achievable allocation for the WES Boring STP.

The wasteload allocation for the City of Dallas would result in an effluent temperature target of 18.2 C in May and October based on the stream flow and effluent flow specified in the TMDL. While effluent temperatures in May and October are below the peak summer temperatures, they are likely well above

18.2 C particularly in October. As noted in the April 2023 comment letter, the City has a long history of working with DEQ to address temperature issues in Rickreall Creek and has expended considerable resources over the past three decades. The City has continued to discharge to Rickreall Creek rather than build a pipeline to the Willamette River at the behest of Oregon DEQ, Oregon Department of Fish and Wildlife and downstream water users. In the 1990s, the City applied for and obtained an exception to the temperature standard from the Environmental Quality Commission. The proposed wasteload allocation does not provide a viable pathway for the City to continue to discharge to Rickreall Creek during the entire dry season (May to October).

These are but three examples of potential compliance concerns with the proposed wasteload allocations in the TMDL. There may be other cities that have similar concerns. We urge DEQ's TMDL and permitting groups to conduct a compliance assessment of the ability of municipal treatment facilities to meet the wasteload allocations in the TMDL. If the proposed wasteload allocations in the draft TMDL would result in non-compliance, DEQ should utilize a portion of the reserve capacity and if need be, conduct a cumulative effects evaluation to provide an achievable wasteload allocation for the facility.

We further urge DEQ to reach out to these cities to discuss the proposed TMDL wasteload allocations and viable permitting pathways that continue to ensure both the efficient use of limited resources and sufficient flexibility to direct resources to projects with sustainable environmental, community, and economic benefits.

Wasteload Allocations for Water Treatment Facilities (200-J NPDES General Permits)

There are six registrants for the 200-J NPDES general permit that are identified in the TMDL, and wasteload allocations are included for these sources. The 200-J NPDES permit authorizes discharge of filter backwash from drinking water treatment plants. The water used to backwash the filters is often treated in a settling pond prior to discharge to surface waters. Solar heating of the ponds, which are used to settle solids, is the primary source of temperature increases at these facilities.

Inclusion of facility-specific waste load allocations would likely make these facilities ineligible for the 200-J NPDES general permit. These facilities would have to apply for individual NPDES permits at considerable cost, which would place a significant economic burden on these municipalities, and would add more permits to DEQ's workload, for little or no environmental benefit. Wasteload allocations leading to numeric limits, which would require issuance of individual permits, are an inappropriate vehicle to address thermal contributions of filter backwash discharges from drinking water treatment facilities. We recommend that DEQ utilize a management practice based approach to reduce potential thermal load from these facilities. Management strategies include consideration of non-discharge alternatives (i.e., land application) and/or operational changes to the extent feasible to minimize the thermal load from these facilities.

In the 2006 TMDL, DEQ included a bubble allocation for small sources, which include minor individual municipal treatment facilities and General NPDES Permits. The 2006 TMDL noted that the "facilities with a valid permit are included in this "bubble allocation" and may continue to discharge their current heat load without affecting the attainment of temperature standards." The 2006 TMDL states that DEQ "will not assign individual effluent limits to each source within the small point source bubble allocation" but "will track the number of small sources within each river reach and estimate cumulative heat loads based on discharge monitoring reports or other effluent characterization approaches." The 2006 TMDL

also states that “available reserve capacity will be drawn upon as the small source heat load approaches the bubble allocation limit.”

DEQ should use a bubbled allocation approach for small sources similar to what was done in the 2006 TMDL. DEQ has not provided data or modeling to demonstrate that a different conclusion and, therefore, a different policy approach, is warranted, and no reasoning has been provided for changing from the approach taken in 2006. Moreover, the permit compliance and cost implications of including waste load allocations for small discharges would be significant, while the temperature reduction impact would be negligible. Using the bubbled allocation approach provides an effective and efficient means of addressing these discharges and will not add to DEQ’s permitting workload.

Alternatively, DEQ should utilize a management practice-based or pollutant reduction plan approach to address potential thermal impacts from minor sources under the 200-J NPDES permit. Upon renewal of the 200-J NPDES General Permit, DEQ can require management plans that include best practices for managing temperature at these facilities.

Thermal Load Allocation for Non-Point Sources

Section 9.1.4.3 states “Local geology, geography, soils, climate, legacy impacts, natural disturbance rates, and other factors may prevent effective shade from reaching the target effective shade. No enforcement action will be taken by DEQ for reductions in effective shade caused by natural disturbances.” This section notes that “no enforcement action will be taken by DEQ for reductions in effective shade caused by natural disturbances.” We recommend that DEQ include an additional statement which states that “where natural disturbances prevent achievement of the target effective shade, DEQ will work with the DMAs to develop plans to restore riparian vegetation.” Inclusion of this statement will make it apparent that shade loss caused by natural disturbances will be restored.

Table 9-13 provides shade gaps for selected DMAs. Please provide an explanation for how this list of DMAs was selected and why some DMAs received shade gaps and not others.

Table 9-18 presents the vegetation height, density, overhang and buffer width used to derive effective shade curve targets. A buffer width of 36.8 meters (120 feet) is used for deriving the effective shade curve targets for each mapping unit. As noted in the discussion regarding the allocation of the human use allowance, local jurisdictions have very limited ability to require or incentivize private property owners to provide a 120-foot buffer width. Additionally, site constraints often restrict the establishment of a 120-foot buffer width. Thus, the assumed buffer width used to derive the effective shade curve targets will likely not be achievable in many areas. We recommend that DEQ include discussion in Section 9.1.4.3 that the shade curves presented in Figures 9-5 to 9-26 and in the Appendix of Effective Shade Curve Tables are based on an assumed vegetation height, density, overhang, and buffer width; these are idealized conditions and not representative actual field conditions. Thus, the effective shade targets obtained from the shade curves do not reflect site potential conditions; the effective shade obtained from the shade curves should be used as a guide to evaluate progress and not as actual effective shade targets.

WATER QUALITY MANAGEMENT PLAN (WQMP):

Section 2. Proposed Management Strategies

Section 2 of the WQMP identifies proposed management strategies; these include streamside vegetation management strategies, flow management strategies, and hydromodification management strategies. The WQMP identifies specific management practices in each category.

In Table 2, “Solar Radiation” is listed as a pollutant. While solar radiation is the primary source of thermal inputs in the Willamette Subbasin TMDL, it is not a pollutant. Solar Radiation should be replaced in the table with “Temperature” as the specified pollutant of concern. A footnote or table note could be added to note that solar radiation is the primary source of thermal pollution.

Water Withdrawal Management Strategies

Section 2.2 discusses flow management strategies. This section notes that because “temperature is a flow-related parameter, water withdrawals can result in increased pollutant concentrations and warmer stream temperatures.” The WQMP recommends the pursuit of “instream water rights transfers and leases.” Reliance on instream water rights and leases as the vehicle to implement this management strategy will not tap its full potential. This management strategy needs to be more fully developed as there is significant untapped potential to leave cool water instream and offset its consumption with recycled water. Recycled water from municipal wastewater treatment facilities is a viable alternate source of water for many consumptive uses and using it in-lieu-of river water has the double temperature benefit of eliminating a discharge of warmer water to the stream and leaving cooler water in the stream. DEQ should take necessary steps to facilitate expansion of the permitted use of recycled water which would allow entities to transfer water rights for in-stream use. For the purposes of this WQMP, DEQ should incorporate the framework for additional means (other than water rights transfers or leases) for achieving temperature compliance through recycled water offsets to withdrawals, such as contracts.

Additional strategies to address water withdrawals include expanding the use of Aquifer Storage and Recovery (ASR) systems for municipal use. These systems can be used to store water in the wet season and use the stored water in the dry season. This provides a viable method for communities to reduce surface water withdrawals during the dry season. These strategies also should be developed in the WQMP.

Summary of Nonpoint Source Priority Management Strategies

Section 2.4 of the WQMP includes “proven strategies (and practices within the strategies) by pollutant source.” Table 2 summarizes these strategies. ACWA agrees with the information included in the table, but the table is incomplete. Dam and reservoir management should be included as a specific priority strategy. Additionally, the information on flow management strategies should be expanded to reflect the comments provided above.

While water withdrawals and channel morphology/hydromodification management strategies are specified as priority management strategies, there is no opportunity to get “credits” for implementation strategies/measures that would address them. The WQMP should include broader discussion of these strategies and include a framework for obtaining thermal “credits” for implementing these strategies. A greater focus by DEQ on these priority management strategies could be developed as a means to achieve the TMDL temperature targets since target effective shade may not be achieved.

Point Source Priority Management Strategies

Section 2.5 discusses point source priority management strategies. The discussion of point source priority management strategies is inadequate. Point source dischargers cannot implement the priority management strategies without viable permitting pathways. The WQMP should include the range of permitting pathways that exist and that need to be developed in order to enable point source dischargers to have access to the priority management strategies as a means of permit compliance for temperature limits. Examples that need to be addressed in this section (or elsewhere in the WQMP as DEQ responsibilities) include, but are not limited to:

- Water quality trading: DEQ should provide a discussion for the framework for the water quality trading program in the WQMP.
- Mechanisms for pilot projects or a specific set of performance metrics that can constitute NPDES permit compliance for priority management strategies related to river system (channel morphology and hydromodification) improvement projects such as channel morphology improvements, floodplain function improvements, hyporheic flows through shallow gravels, etc.
- A broader set of mechanisms for crediting water left instream and offset by recycled water use.
- Pathways to site specific variances and implementation of pollution reduction plans in-lieu-of numeric temperature limits.

Section 5. Implementation Responsibilities and Schedule

Identification of Implementation Responsibility

Section 5.1 on page 16 states that “*A complete list of responsible persons including DMAs for the Willamette Subbasins Temperature TMDL is in Appendix A. Appendices B and C contain further information divided by subbasin and show jurisdictional area of each DMA by subbasin and within 150 feet of a stream.*” In reviewing Appendices A, B, and C, we noted many discrepancies when comparing the acreages to jurisdictional mapping and subbasin delineation results. For Phase I NPDES MS4 jurisdictions, contributing area by watershed in accordance with the Willamette Basin TMDL has been detailed and submitted with their NPDES MS4 permit renewal applications and TMDL pollutant load reduction evaluations (PLRE) and benchmarks. These would be the appropriate acreages to include in these tables. We recommend removing these listings of areas altogether and instead list the relevant subbasins for each DMA. The areas do not seem to be necessary information unless they were used in DEQ calculations – in which case, the areas and calculations should be corrected.

- For example, Appendix B shows that Oregon City has 878 acres in the Clackamas Subbasin and zero acres in the Middle Willamette Subbasin. Oregon City has estimated through GIS mapping that it has 5487.2 acres in tributary areas to the Middle Willamette and 123.8 acres in areas draining directly to the Middle Willamette. Appendix A shows a total for Oregon City of 6437 acres. So, Appendix A and B don’t add up.
- Another example includes Gladstone’s drainage area of 20 acres to the Middle Willamette subbasin. Gladstone does not have any drainage to the Middle Willamette Subbasin.
- Oak Lodge Water Services is mistakenly not included in Appendix A, B or C of the WQMP.
- Additional examples can be provided on request.

Since flow management is an essential component of the proposed management strategies in the WQMP, the Oregon Water Resources Department (OWRD) has an important role. OWRD’s mission statement notes that its role is “to restore and protect stream flows and watersheds in order to ensure the long-term sustainability of Oregon’s ecosystems, economy, and quality of life”. OWRD’s role in ensuring sustainable stream flows is a key a component of meeting temperatures targets. Therefore, we recommend that OWRD be listed as a DMA in the WQMP.

Existing Implementation Plans

Section 5.2.1 includes a discussion of the adequacy of the Forest Practices Act (FPA) to meet TMDL allocations. This section notes that “the rules do not address disturbance of riparian areas harvested under previous rules. It states: “Therefore, effective shade is likely to be deficient for those riparian areas adjacent to small and medium salmon, steelhead, and bull trout streams that were harvested prior to implementation of the new rules.” This approach precludes the attainment of target effective shade. If there is no active restoration in watersheds impacted by previous rules, the effective shade targets will not be achieved. To achieve the effective shade target and improve water quality, it seems that the FPA would have to be amended to require protection and restoration of previously impacted riparian areas.

Implementation Plan Requirements

Section 5.3 addresses Implementation Plan requirements. The TMDL requires DMAs to submit TMDL Implementation Plans within 18 months of EPA’s approval of the Willamette Basin mainstem TMDL. DMAs identified under the previous Willamette Basin TMDLs would have already submitted plans. If TMDL implementation plans need to be updated to reflect new requirements, DEQ should identify the specifics of the plan update rather than requiring wholesale updates. This effort for all DMAs to submit new implementation plans would be duplicative, resource intensive, and unnecessary to achieve the desired updates to TMDL implementation plans.

As shown in Figures 1 and 2 of the WQMP, most of the acreage in the Willamette Subbasins is under the purview of federal and state agencies. Rather than requiring 137 DMAs to provide new implementation plans, DEQ should require Oregon Department of Forestry, Oregon Department of Agriculture, US Bureau of Land Management, and US Forest Service to update their plans. These entities make up 93% of the DMA acres in the stream corridor in the Willamette Subbasins TMDL. While new DMAs need to submit TMDL implementation plans, existing DMAs that already have TMDL implementation plans should be allowed to update their plans as part of annual reports submitted to DEQ. This approach will reduce the burden on DMAs but ensure that DEQ gets the necessary information. Additionally, this approach will enable DEQ to focus its efforts on the entities that account for most of the acreage in the stream corridor in the Willamette Subbasins Temperature TMDL.

Section 5.3, Figure 3 includes a decision support tree to help identify information and analyses requirements for different responsible persons and DMAs. The decision tree does not include responses (Yes/No) to guide the reader through the figure. Please include responses (Yes/No) to assist the reader navigate the decision tree.

We found the draft WQMP to be unclear regarding which DMAs are required to conduct a shade gap analysis.

- Section 5.3.2 (Streamside Evaluation) states that “*Entities that have a DEQ shade gap analysis, and entities that must complete a shade gap analysis (see Section 5.3.4), must account for the shade gap analysis results in their streamside evaluation.*” However, Section 5.3.4 does not specifically state who must complete a shade gap analysis – it just describes what a shade gap analysis is. ACWA requests that DEQ specifically state which DMAs do not have to do a shade gap analysis.
- What is meant in the first paragraph under Section 5.3.2 of the draft TMDL WQMP document by “*Entities that have a DEQ shade gap analysis, and entities that must complete a shade gap*

analysis (see Section 5.3.4) must account for the shade gap analysis results in their streamside evaluation.”? Specifically, for clarification, what is meant by “must account for”?

- Section 5.3.4.1 talks about what DMAs must do if they have been provided a shade gap analysis by DEQ. But, this section does not specifically state what to do if you are a jurisdiction that has not been provided with a shade gap analysis by DEQ.
- The shade gap analysis would be generated using a HeatSource model. There are limitations and conflicts when using HeatSource 7 and HeatSource 8 from out of date versions of the TTools in ArcGIS and macros in Microsoft Excel. ACWA encourages DEQ to finalize HeatSource 9 and release it so that it is readily usable by DMAs as a TMDL implementation tool.
- In Section 5.3.4.1 of the draft WQMP, for those who are required to do a shade gap analysis, if using method 1, it states you must determine vegetation type. Please clarify that these are general categories of vegetation types.

Use and Applicability of Shade Curves

We found the draft WQMP to be unclear regarding the intended use of shade curves. Section 5.3.4 states that “*Where DEQ was unable to conduct a shade gap analysis, shade curves were developed (Figures 9.1-9.22 in the TMDL Rule) to allow users to find target percent effective shade values for streams based on several stream characteristics.*” This sentence could lead one to believe that if DEQ did not conduct a shade gap analysis for a DMA then shade curves can be used to conduct a gap analysis. Please clarify how the shade curves should be used and its correlation to a shade gap analysis. This information should be included on Figure 3 as well. Also, DEQ should explain why it performed Shade Gap Analyses for some jurisdictions or areas of the basin but not all.

In terms of shade curves, they are provided by a mapping unit identifier. The text in Section 9.1.4.3 of the draft Willamette Subbasin TMDL document states that you can find the location of mapping units in Appendix H. Appendix H does not include a link to the map. Please provide a link to the online map in the document itself.

In addition, the draft TMDL document does not explain a way to use the map to find mapping unit identifiers to match up with the shade curves. Please provide instructions on how to find mapping unit names on the map. For example, how would you find where the Qff1 mapping unit applies on the map? The example in Figure 9-3 of the draft TMDL document shows a legend which would be very helpful in using the maps. However, this legend does not show up when using the online map. Please provide clarification in the steps provided under “*how to use a shade curve*” beginning on page 52 of the draft TMDL document. Additionally, it would be helpful to have an overlay of city boundaries on the online map. Currently if you select the “ownership and jurisdiction” layer, you can’t also see the “shade curve mapping units” at the same time. In addition, the “ownership and jurisdiction” layer includes different colors on the map but there is not a legend to indicate what the different colors mean.

With respect to Figure 3 in the draft WQMP, if a DMA did not receive a shade gap analysis from DEQ, would one of the options be to select a 120 ft streamside buffer in addition to the option of submitting a streamside evaluation plan and implementation plan? If so, DEQ should specify this as an option in Figure 3.

Section 5.3.3 of the draft WQMP allows for the option of a “*120-foot slope width buffer zone*”. What is meant by a “*slope width buffer zone*”? Specifically, what is the meaning of the word “*slope*” in this term?

Thank you for your consideration of ACWA's comments. If you have any questions, please do not hesitate to contact me.

Sincerely,

Jerry

Jerry Linder
Executive Director

ATTACHMENTS: City of Creswell Temperature Data
Memorandum from the City of Gresham



City of Gresham Case
Study--non point sour



Creswell_Temperatur
e_ETL_data.xlsx

From: [Calvert, Paula P \(BPA\) - E-4](#)
To: [TEMPERATURETMDL Willamette * DEQ](#)
Cc: [Leary, Jill C \(BPA\) - LN-7](#)
Subject: Extension Request for Public Comment Period
Date: Tuesday, February 20, 2024 4:10:11 PM

You don't often get email from ppcalvert@bpa.gov. [Learn why this is important](#)

Hello Michele,

I would like to request an extension of the public comment period for the Willamette Subbasins Temperature TMDL, which currently closes on February 23.

Thank you for your consideration.

Best regards,
Paula

Paula Calvert

Clean Water Act Policy Advisor | Fish & Wildlife, E-4

BONNEVILLE POWER ADMINISTRATION

[bpa.gov](#) | P 503-230-5651 | C 360-684-0294 | ppcalvert@bpa.gov





February 16, 2024

Michele Martin, Project Manager
Project Team
DEQ Water Quality Division
700 NE Multnomah Street, Suite 600
Portland, Oregon 97232

Sent via email to: Willamette.TemperatureTMDL@DEQ.oregon.gov;

Subject: Comments on the Draft Total Maximum Daily Loads for the Willamette Subbasins – Temperature (January 2024)

Dear DEQ Willamette Tributaries Temperature TMDL Team:

Thank you for the opportunity to provide input to the Draft Temperature Total Maximum Daily Load (TMDL) for the Willamette Tributaries Temperature made available for public review in January 2024.

The City of Dallas operates a wastewater treatment plant (WWTP) that discharges to Rickreall Creek at river mile 9.3 under an NPDES-DOM-C1a permit (Dallas STP NPDES Permit # 101518). The City has worked with DEQ for over 20 years to improve the assessment of water quality, fisheries, and temperature issues on Rickreall Creek and wants to ensure that the updated TMDL continues to address the unique conditions of Rickreall Creek, reflecting information previously presented in the 2006 Middle Willamette Subbasin Temperature TMDL and subsequent discussions between the City, DEQ, and ODFW. The City is also monitoring the TMDL update process closely to ensure that the City's options for compliance solutions to excess thermal loads are not impaired through the TMDL update process.

Further background on the City of Dallas and Rickreall Creek are provided below. Please note that *key recommendations are highlighted in bold and italic type.*

Location of the Dallas WWTP:

Due to the different fish use designations along Rickreall Creek, it is important that the location of the Dallas WWTP outfall be accurately reflected in the TMDL.

The Dallas WWTP discharges at river mile 9.3 per the NPDES permit, not river mile 10.5 as indicated in Table 7.1 of the January 2024 draft TMDL. Please correct the discharge location.

Rickreall Creek Fish Use Designations and Temperature Criteria:

Rickreall Creek was addressed specifically in the 2006 Middle Willamette Subbasin Temperature TMDL to address the “cool water” designation of the lower portions of the creek.

See pages 7-5, 7-15, 7-18, 7-25, 7-31, and 7-32 of the 2006 Middle Willamette Subbasin Temperature TMDL for discussion related to temperature criteria for Rickreall Creek.

There have been several new developments since the 2006 TMDL that have helped to clarify fish usage and applicable temperature criteria including:

- At the time of the 2006 TMDL, USEPA had not yet approved the cool water criteria. However, DEQ received USEPA's approval of the cool water species designation in Oregon's water quality standards in 2010, described in a March 10, 2010 letter from Michael Bussell/USEPA to Neil Mullane/DEQ. The approved cool water criteria is now acknowledged in the January 2024 draft TMDL with application to Rickreall Creek described in Section 4.2.
- At the time of the 2006 TMDL, Oregon Department of Fish and Wildlife (ODFW) had not yet completed their assessment of cool water species present in Rickreall Creek. In 2015, DEQ initiated consultation with ODFW which further established fish use and a temperature criterion protective of the cool water species present. In Section 4.2 of the January 2024 draft TMDL, the results of this consultation are presented and a 22.8 degrees Celsius (°C) temperature criteria is presented as applicable June 1 – September 30 of each year for protection of cool water species.
- In the current Oregon water quality standards (OAR 340-041), the Fish Use Designations (Figure 340A) identifies the lower reach of Rickreall Creek as Cool Water Species use. In the Salmon and Steelhead Spawning Use Designations (Figure 340B), portions of the upper reaches of Rickreall Creek are designated for spawning use from January 1 through May 15.

One of the most significant changes in Rickreall Creek temperature targets in the Draft TMDL compared to the 2006 TMDL is the proposal for an October 1 – May 31 period temperature criterion of 18 °C. In the 2006 TMDL, the migration corridor criterion of 20 °C was presented as applicable to Rickreall Creek during the seasonal migration of anadromous salmonids through the lower reach of Rickreall Creek. In the January 2024 draft TMDL, the more restrictive 18 °C temperature criterion for salmon and trout rearing and migration was proposed based upon species that may be rearing in the lower reaches of Rickreall Creek seasonally. It is not clear what actual fish survey evidence was used to establish this conclusion.

We generally agree with the unique conditions of Rickreall Creek addressed in the document. We agree with the cool water period being from June 1 – September 30 and the 22.8 °C criterion during this period. We request that DEQ re-evaluate the temperature criterion of 18 oC during October 1 – May 31 and consider the application of the migration corridor criterion of 20 oC presented in the previous TMDL.

Human Use Allowance Allocations for Rickreall Creek:

Human use allowances for Rickreall Creek are presented in the draft TMDL in Table 9-5.

We question why other tributaries are allocated a 0.20 °C human use allowance to NPDES point sources and 0.03 °C to reserve capacity, but Rickreall Cr is only allocated 0.15 °C to NPDES point sources and 0.08 °C to reserve capacity. We request changing the allocation for NPDES point sources to 0.20 °C like in other tributaries in the document.

City of Dallas Strategies for Thermal Load:

The City has been evaluating options to address potential thermal load limits in a future NPDES permit for more than 15 years. Options have considered a wide range of potential strategies and depending upon the outcome of the updated TMDL, could require a combination of excess thermal load (ETL) mitigation strategies. One strategy that the City wants to ensure remains a viable option is the application of water quality trading using riparian vegetation enhancements to block solar loads to Rickreall Creek and to offset ETLs resulting from wastewater effluent discharge. Without water quality trading as a viable option for offsetting ETLs, dischargers will be left with less favorable options such as cooling towers, chillers, and/or projects that reduce stream flows downstream.

Dallas Water Treatment Plant (WTP)

Dallas is a 200-J NPDES general permit holder identified in the TMDL with a waste load allocation included sources. The 200-J NPDES permit authorizes discharge of treated filter backwash from the City's drinking water treatment plant. The water used to backwash the filters is treated in a settling pond prior to discharge to Rickreall Creek. Solar heating of the backwash pond used to settle solids is the mechanism for temperature increases in the treated backwash water. The primary mechanism to reduce thermal impacts is through the implementation of management practices to the extent they are operationally feasible.

We are concerned that inclusion of this facility-specific waste load allocation would likely make the WTP ineligible for the 200-J General NPDES Permit. This facility would have to apply for an individual NPDES permit at considerable cost, which would place a significant economic burden on the City for questionable benefit. It does not appear that DEQ has thought through the permitting implication and compliance mechanisms associated with regulating this type of discharge through numeric temperature limits that would arise from the prescribed waste load allocations. Clearly, this discharge should be addressed, to the extent practicable, through management practices, without the potential requirement of cooling towers or chillers. *Utilizing a management practice-based approach would enable DEQ to ensure that appropriate actions are taken at the water treatment plant to minimize temperature impacts and would ensure that filter backwash discharges continue to be eligible for the 200-J General NPDES Permit.*

In addition, this small point source discharge does not contribute significantly to the cumulative heat sources to the Willamette River and the "bubble allocation" approach provided for small point source discharges in the 2006 TMDL should be retained. Further, instead of the wastewater plant and water plant getting an equal portion of the HUA, can the allocations between the water treatment plant and the wastewater treatment plant be shared?

We further expect that when the 200J filter backwash water discharge permit is renewed, and an individual NPDES permit not required, that the 200J permit acknowledges the thermal load WLA assigned to their drinking water plant.

We appreciate the opportunity to provide input to the Willamette Tributaries Temperature TMDL replacement project.

Sincerely,



Brian Latta
City Manager
City of Dallas

February 26, 2024

Michele Martin
DEQ Water Quality Division
700 NE Multnomah Street, Suite 600
Portland, Oregon 97232-4100

Sent via email to: Sandy.SubbasinTMDL@DEQ.oregon.gov and
Willamete.TemperatureTMDL@DEQ.oregon.gov

Subject: City of Gresham Comments on the Draft Lower Columbia-Sandy and Willamette Subbasins Temperature TMDL

Dear Michele Martin,

Gresham appreciates the opportunity to comment on the Lower Columbia-Sandy Subbasin and the Willamette Subbasin Total Maximum Daily Load (TMDL) updates. As a lower-income municipality with 68 miles of stream resources within portions of both the Sandy and Willamette subbasins, over the last 20 years, Gresham has endeavored to efficiently invest public resources in stream temperature improvements within the Johnson/Kelley Creek; Fairview Creek/Columbia Slough; and Kelly/Burlingame/Beaver Creek watersheds. The City has integrated Temperature TMDL commitments into our land use code, stormwater monitoring, maintenance programming, and stormwater and natural resource master planning. Gresham echoes the comments made by the Oregon Association of Clean Water Agencies in response to the proposed Temperature TMDL updates for both subbasins, and in the interest of wanting to assist DEQ with developing realistic and achievable plans to improve stream temperatures in both basins, we're offering the following comments from the perspective of implementation practitioners.

Fiscal Analysis

While recognizing the court-mandated deadlines for these updates lead to DEQ relying on pre-existing data sources where possible for these updates, it should be noted that the Fiscal Analysis completed for both subbasins depended on quite out-dated project cost data, as compiled in "DEQ's Cost Estimate to Restore Riparian Forest Buffers and Improve Stream Habitat in the Willamette Basin, Oregon (2010)." That document presents riparian and in-stream project costs that are 15-18 years old, and which are based on project areas typically outside confined urban areas. Projects in urban areas typically have to meet multiple objectives to fit into the constrained landscape, and incur additional project costs. Gresham has an extensive list of recognized riparian and in-stream restoration needs that far exceed our ability to take on even low interest debt of the type outlined in the DEQ fiscal analyses. The degree of staff time and matching resources needed for pursuing grant options impact progress via those routes as well. The fiscal analysis states rate payers may incur costs, but at least in Gresham, it's a certainty that these natural resource investments will impact stormwater rate payers. The statements in the fiscal analysis about the income generated by Portland area tourism should not be portrayed as a relevant compensating variable for low-income suburbs that are rarely tourist destination hot spots. In short, the fiscal analysis as currently written doesn't speak to implementation feasibility or inform implementation rate projections for at least one low-income suburb. DEQ staff reviewing annual and 5-year reporting requirements during the 2/16/24 webinar enumerated reporting requirements for DMAs, and notably, actual project costs were not mentioned, despite the importance of fiscal resources in making forward progress. To better inform future DEQ decisions on adequacy of adaptive management proposed by DMAs, future Temperature TMDL updates, or

state funding decisions to support DMA progress, we recommend DEQ begins requesting basic, standard reporting metrics on actual incurred costs for riparian and in-stream restoration costs when either annual or 5-year progress reports are submitted by DMAs. DMAs could submit project-specific costs on a \$X/acre for 5-year riparian restoration projects, and \$X/linear ft of in-stream restoration.

Strategies Beyond Shade Needed

The predominant focus on shade may be insufficient for some subbasins, per the information provided by Appendix A of the Willamette TMDL. DEQ's Effective Shade Model on Johnson Creek is presented in Figure 3-22 of Appendix A in conjunction with actual field measurements of existing shade (pasted below). The model appears to be a poor fit when with the recent field observations presented by DEQ. In a quick comparison, the average modelled shade at the validation points was ~35%, while the real observations at those same points averaged ~79%--more than twice as much real shade as in the model DEQ is using.

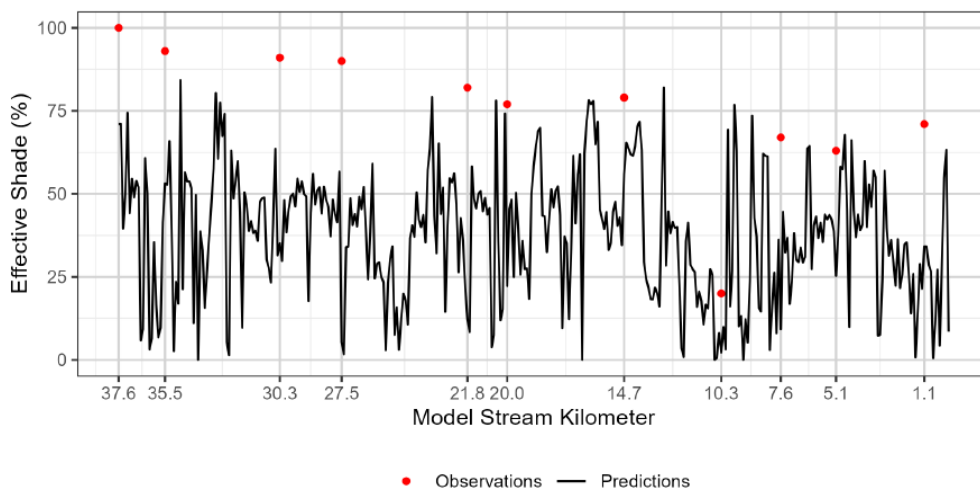

Figure 3-22: Johnson Creek field observed and predicted effective shade.

A main conclusion from the WQMP documents is that to meet the Water Quality Temperature Standard, DMAs need to increase shade, and that if we increased shade to its potential, we would generally stay below the Standard (see Fig 4-1 in the same Appendix document). However, if Johnson Creek already has more than twice the shade that the model suggests and yet that subwatershed is still routinely exceeding the temperature standard, will this predominant focus on stream shade result in temperature improvements as assumed by the DEQ modeling? These data sources suggest Gresham would be expected to increase shade where it is already at or near full potential. And, while the conflict between the Effective Shade model and actual conditions sets the jurisdiction up to easily demonstrate improved stream shade conditions when comparing current conditions against the 2002 baseline (as established by the Effective Shade Model), Gresham is motivated to invest efforts where public resource investment will contribute to real temperature improvements when combined with the investment of other Johnson Creek stakeholders.

Recent water quality monitoring on Johnson Creek has resulted in DEQ expanding the critical period window for Johnson Creek to February 15 through November 15, newly reflecting heat exceedances during the time of year that we have leaf-off conditions. It is unlikely that direct solar radiation is the source of heat loading in the late fall and late winter months that have been added to the critical period, thus strategies other than shade are especially important to explore. In Gresham's experience the Water Quality Management Plans strategies, as listed in Table 2 of the Willamette Subbasin WQMP should include the following.

1) The impacts of private reservoirs/in-channel impoundments

We recommend adding language that requires all in-channel ponds over an acre to be addressed, instead of focusing only on those located on publicly owned land. Both DEQ and Gresham are aware of the sometimes substantial heat loadings from both public and private in-channel ponds in these subbasins. Gresham has tried multiple strategies over the last 20 years to incentivize stream restoration and/or riparian improvements in areas where historic stream impoundments were created as a centerpiece aesthetic feature for a subdivision, or as recreational features for golf courses. Despite numerous long-standing efforts, only negligible changes have resulted with no discernable reduction in heat loading. The City lacks authority to require private in-channel impoundments be retrofitted to address heat loading without TMDL language necessitating these areas be addressed, yet it may be private impoundments that are the larger heat source in some systems. The current focus on public reservoirs may miss significant heat sinks. For instance, Gresham will be required to report on continued efforts to improve a 1.5-acre publicly owned pond surrounded by trees on Butler Creek (tributary to Johnson Creek), while immediately upstream, an entirely unshaded 1.3-acre private pond will remain unaddressed, under the current draft of the Willamette Subbasin WQMP. On another Johnson Creek tributary (Hogan Creek) a private golf course system of in-line ponds and a Homeowner Association-maintained in-channel impoundment contribute over 5 acres of privately owned, unshaded reservoirs and those will continue to contribute substantial heat loading to designated critical habitat. Kelly Creek (a tributary to the Sandy River) has summer flows that are largely groundwater-fed and often attain the temperature standard until the creek passes through a golf course and then heats up further in the 1.7-acre private pond on Mt. Hood Community College campus. Fairview Creek is also largely groundwater-fed and generally attains the temperature standard throughout the summer except where large in-channel ponds are present. Publicly owned Fujitsu Ponds (~20-acres) are a high priority for Gresham to retrofit, and opportunities are being pursued. Downstream of these ponds, Fairview Creek empties into a >100-acre private reservoir from which the Columbia Slough emerges, and no amount of shade can offset that impact. Tree shade may help prevent heat loading from direct sun, but shade can't be assumed to offset heat loading upstream. By not including privately held in-channel impoundments in these Temperature TMDL updates, at least a portion of public investment in downstream shade improvements are negated.

2) *Protection of shallow subsurface groundwater.*

Gresham has documented reaches of sub-surface cold water inputs in both the Sandy subbasin (Kelly Creek) and the Lower Willamette subbasin (Johnson/Kelley Creeks). These inputs are found to create cool areas in these streams, even in areas without the benefit of riparian shade. Protection of "groundwater inflows" and correspondingly, "stream volume" are mentioned specifically in OAR 340-041-0028(11) yet aren't part of the criterion or considerations presented in either the Willamette or Lower Columbia-Sandy Subbasin WQMPs. Disruption or exposures of shallow groundwater and related reduction of bank storage and decreased support of hyporheic flow are anthropogenic sources of warming, thus we recommend that Department of State Lands (DSL) and Oregon Department of Geology and Mineral Industries (DOGAMI) have more explicit requirements for managing temperature than what is currently indicated in both the Sandy and Willamette Subbasin WQMPs. While DSL and DOGAMI are listed as DMAs under the Temperature TMDL updates, both are currently exempted from having any type of implementation plan responsibility due to their limited ownership of streamside property that could be shaded. However, their jurisdictional decisions have significant impacts on preservation of groundwater inflows, stream volume, and cold water refuge support throughout many watersheds in the state, including those relevant to the Temperature TMDL updates discussed here.

While the full Temperature Management Implementation Plans required of most DMAs may not be appropriate for these agencies given their state-wide activities, Gresham would recommend to DEQ that these DMAs are expected to consider their mitigation decisions in the context of the 5th and 6th field HUC

scales at which DEQ regulates other DMA activity. Even the minimal degree of reporting expected of reservoir operators to demonstrate their management activities aren't resulting in heat loading of a given stream seems a reasonable minimum to expect of these state agencies so that their management decisions are not made without considering temperature impacts to TMDL streams. An equivalent expectation could be to report on impacts permitted and mitigation required within the relevant 5th or 6th field HUC. Future riparian tree planting efforts cannot offset current heat exceedances as well as offset future decreases in infiltration, groundwater flow, bank storage, and hyporheic flow support that occurs when nearby wetlands are filled and then mitigated for elsewhere in the state (via in lieu fee payments) or mitigated at a 3rd or 4th field HUC scale.

Similarly, no amount of stream shading can offset the changing hydrology conditions that come from industrial mining sites where industrial discharges start and stop to accommodate extraction activities. Groundwater monitoring near Fairview Creek (in the Lower Willamette) demonstrates that the groundwater gradient is reversed during certain mining activities, and stream flows are significantly altered as mining activities evolve at a site, affecting the survival of riparian vegetation—even negating all past public investment in riparian conditions.

These actions are the largest impacts on bank storage and stream volume Gresham has noticed to date, yet are not addressed in the current Temperature TMDL updates.

Locally Significant Wetlands

Gresham requests that DEQ incorporate into their Temperature TMDL update process a review and collaborative revision of OAR 141-086-0350 (2)(b), in conjunction with the relevant state agencies. The existing language was developed by a technical advisory committee in the late 1990s in association with DSL, DLCDC, and DEQ staff, prior to any TMDL approvals in Oregon. The language is the primary directive used by local jurisdictions to require buffer protections of wetlands meeting local significance criteria. Recent challenges to Gresham's legal ability to consider a wetland "locally significant" due to proximity of a 303(d)-listed waterway have highlighted the need for this language to be reviewed and updated at such times that DEQ alters their assessment of streams for inclusion on the 303(d) list and for TMDL listing. If that language does not reflect current DEQ practices, local jurisdictions may lose justification for local wetland protections, and therefore lose the ability to protect these areas on the landscape that are critical for infiltration, groundwater flow, bank storage, and hyporheic flow support.

Please contact me if Gresham's Natural Resources or Water Quality Program can provide any additional information on the comments provided here.

Sincerely,

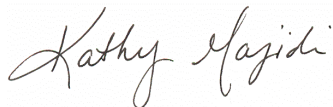

Kathy Majidi
Natural Resources Program Manager



February 13, 2024

Ms. Michele Martin
Oregon DEQ Water Quality Division
700 NE Multnomah St #600
Portland, Oregon 97232-4100

Dear Ms. Martin:

We appreciate the opportunity to provide comments on the revised Willamette Subbasins TMDL for Temperature. We understand and appreciate the large effort undertaken by DEQ staff and their consultants to finish this project and have mostly minor comments only on the Water-Quality Management Plan (WQMP) and on the Technical Support Document.

In the draft version of the Willamette Subbasins TMDL for Temperature, the Tualatin River subbasin was specifically excluded because its temperature TMDL did not use the natural conditions criterion. Figure 2-1 of the revised temperature TMDL appears to show that many of the streams within the City of Lake Oswego's ("City") jurisdiction are covered under this revision. We respectfully submit the following comments:

Figure 3 of the WQMP

Figure 3 of the WQMP provides options in the flow chart but does not provide decision directions.

The City requests that Y/N flags be used in Figure 3 of the WQMP to the revised temperature TMDL to clarify the process.

Section 5.3.5 and Appendix E (List of Large Reservoirs) of the WQMP

In 2022, Oswego Creek was added to DEQ's Integrated Report and, in Appendix D of the Technical Support Document for the draft temperature TMDL, Oswego Creek is listed as an assessment unit for year-round and spawning temperature categories.

In Appendix E of the WQMP, the Lake Corporation is listed as a dam owner but was excluded from the DMA list for dam owners (Table 6 of the WQMP). The Lake Corporation manages the

Respect. Excellence. Trust. Service.

water-quality of Oswego Lake and they are the primary source of water in Oswego Creek during the critical time period (April 1 to October 1). The City has very little control over the flow regime of Oswego Creek and by extension its stream temperature especially given the short distance (<0.25 miles above an elevation of 10 feet) for implementing best management practices such as revegetation.

Given the City's lack of control over the flow regime of Oswego Creek and the lack of options for mitigating its temperature, the City respectfully requests that Oswego Creek be removed from the City's responsibility as a DMA.

Appendix D of the Technical Support Document

A minor correction in Appendix D of the Technical Support Document to the revised temperature TMDL – Oswego Lake is listed as Lake Oswego (a common mistake).

The City requests that the assessment unit listed as “Lake Oswego” in Appendix D of the Technical Support Document be changed to Oswego Lake.

Appendix F (Lower Willamette Shade Results) of the TMDL Technical Support Document

In Appendix F of the Technical Support Document for the revised temperature TMDL, the City is listed as the DMA for Park Creek. It does not discharge stormwater to Park Creek. It discharges limited stormwater to the nearby Paget Creek watershed.

Because of the City's limited discharge to the Paget Creek drainage and its lack of discharge to the Park Creek watershed, ***the City respectfully requests removal of its DMA designation for Park Creek.***

Sincerely,

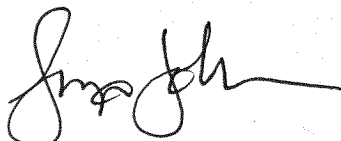

Sonja Johnson, P.E.

Associate Engineer

503.675.3999

SJohnson@LakeOswego.city

Respect. Excellence. Trust. Service.



CITY OF PORTLAND ENVIRONMENTAL SERVICES



1120 SW Fifth Ave, Suite 613, Portland, Oregon 97204 ■ Mingus Mapps, Commissioner ■ Dawn Uchiyama, Director

Michele Martin
DEQ Water Quality Division
700 NE Multnomah Street, Suite 600
Portland, Oregon 97232-4100
Submitted to: Willamette.TemperatureTMDL@DEQ.oregon.gov

February 23, 2024

RE: Comments on the Draft Willamette Subbasins Temperature TMDL

Dear Michele Martin:

The City of Portland's Bureau of Environmental Services (BES) appreciates the opportunity to provide comments on the draft Willamette Subbasins Temperature Total Maximum Daily Load (TMDL). BES manages Portland's wastewater and stormwater infrastructure to protect public health and the environment, and leads the development and coordination of the City's TMDL Implementation Plan.

We acknowledge the Department of Environmental Quality (DEQ) is under a court ordered timeline to complete the series of replacement temperature TMDLs. As one of the first replacement TMDLs, we recognize that the approaches DEQ employs in the Willamette Subbasins TMDL will set a precedent for the subsequent replacement TMDLs. As such, it is critical that issues identified in the draft TMDL be resolved before it is finalized. BES has participated in the Association of Clean Water Agencies (ACWA) TMDL Work Group and is supportive of the comments submitted by ACWA on behalf of its members. This letter focuses on comments of particular relevance to the City of Portland.

Nonpoint Source Human Use Allowance

Nonpoint sources should be assigned a human use allowance (HUA) greater than 0.0°C. A nonpoint source HUA of 0.0°C would require fully vegetated stream corridors with maximum effective shade at every location within a DMA's jurisdiction to achieve the TMDL load allocations. This is not a reasonable goal given site constraints such as, private land ownership, legal authority, infrastructure and safety requirements, and other environmental considerations.

Cities and counties are limited in our authority over streamside land use on private property. Portland implements riparian buffer protection and restoration requirements through development codes and ordinances consistent with Statewide Land Use Goal 5—Natural Resources. Without a development application trigger, we cannot compel private property owners to plant and maintain riparian trees.

Additionally, there are areas within Portland with overlapping jurisdictions where we cannot require or implement riparian plantings. One example is the levee system along the Columbia Slough. The levees are managed for flood protection and at this time, plantings are limited to herbaceous plants to protect the levee infrastructure. The stream reaches bordered by the levees are identified in the TMDL as areas that are expected to achieve maximum effective shade, yet the existing infrastructure precludes tree planting.

The inclusion of a 0.0°C HUA for solar loading from other nonpoint source sectors would set DMAs up for failure – it would require the implementation of shading activities that are beyond our authority. We recommend that DEQ include a human use allowance for nonpoint sources of 0.02°C, similar to the allowance included for transportation corridor, buildings, and existing infrastructure. Including an allocation for nonpoint sources recognizes both the dynamic nature of streamside vegetation and the limitations that DMAs have in achieving TMDL goals.

Nonpoint Source Priority Management Strategies

Include an option for channel morphology/hydromodification management strategies to contribute towards a DMA's attainment of load allocations. BES is highly supportive of the inclusion of channel morphology/hydromodification management strategies as priority management strategies in the Water Quality Management Plan (WQMP). We believe these types of strategies are essential to improving watershed health and have implemented stream restoration projects to improve both stream habitat and water temperature since the 1990s. While the WQMP does include these actions as priority strategies, the TMDL and the nonpoint source load allocations focus exclusively on riparian shade targets.

While the inclusion of these strategies in a DMA's implementation plan is encouraged, implementing these strategies will not contribute towards meeting load allocations beyond the tree planting that may be a part of a project. This will limit the ability of a DMA to utilize these strategies to meet their load allocations. We recommend including a broader discussion of these strategies and a framework for obtaining thermal "credits" for implementing these strategies in the WQMP.

Clarify NPDES Stormwater Contributions

DEQ should update the language in Section 7.1 on page 23 to more directly note that MS4, 1200-C, and 1200-Z NPDES stormwater discharges do not contribute to exceedances of the temperature standard and that no wasteload allocations are necessary. We ask that DEQ amend the current text as follows:

"Based on a review of published literature and other studies related to stormwater runoff and stream temperature in Oregon, DEQ ~~found there is not sufficient evidence to demonstrate~~ concluded that stormwater discharges authorized under the current municipal (MS4s) permits or the construction (1200-C) and industrial (1200-A and 1200-Z) general stormwater permits do not contribute to exceedances of the temperature standard. Therefore, wasteload allocations for these sources are not included in the TMDL."

Other Clarifications

Update Figure 3 in Section 5.3 of the WQMP to include the 'Yes/No' responses in the flow diagram.

Update the note in Table 9-10 in Section 9.1.1. There is an incomplete sentence in the table note.

Thank you again for the opportunity to provide input. If you have any questions regarding these comments, please contact Julia Bond at Julia.Bond@portlandoregon.gov or 503-823-7753 for more information.

Sincerely,

Dawn
Uchiyama



Digitally signed by
Dawn Uchiyama
Date: 2024.02.22
11:32:08 -08'00'

Dawn Uchiyama

Director, Bureau of Environmental Services

February 23, 2024

Michele Martin, Project Manager
DEQ Water Quality Division
700 NE Multnomah Street, Suite 600
Portland, Oregon 97232-4100

Sent via email to: Willamette.TemperatureTMDL@DEQ.oregon.gov

Subject: Comments on the Draft Willamette Subbasins Temperature TMDL

Dear Michele Martin:

Thank you for the opportunity to provide comments on the draft Willamette Subbasins Temperature TMDL. The City of Sandy is the commercial center of eastern Clackamas County and serves a population of nearly 13,000 people. The City is undertaking major infrastructure investments to protect the environment and plan for Sandy's future, including rehabilitating the aging sewer system and upgrading the existing wastewater treatment plant (WWTP).

The Oregon Association of Clean Water Agencies (ACWA) is providing detailed comments on the draft Willamette Subbasins TMDL. We support ACWA's comments on the draft TMDL. Additionally, the City has specific comments related to the discharge from its WWTP, which are presented below.

NPDES Permit

The NPDES permit for the City's WWTP authorizes discharge to Tickle Creek in the Clackamas River Basin from November 1 to April 30. The WWTP produces recycled water for use at a local nursery from May 1 to October 31. The Willamette Subbasins TMDL specifies that the TMDL period for streams in the Clackamas River watershed is from May 1 to October 31. The Willamette Subbasins TMDL does not include a wasteload allocation for the City WWTP because the NPDES permit does not include provisions for surface water discharge during the TMDL period.

The City experiences significant precipitation as a result of its location in the Cascade Mountain range. Even though the NPDES permit characterizes the dry season as May 1 – October 31, the late spring (May/June) and early fall months (September/October) can be quite wet and there may be little or no demand for recycled water during these months. Additionally, the City has experienced intense, short-duration storm events during the late spring and early fall periods (such as the atmospheric river in June 2022), which results in high flows and treated water quantities that far exceed irrigation demand. The City has limited storage capacity, which necessitates discharge to surface waters.

The City requests that DEQ include a wasteload allocation for the City of Sandy WWTP in the Willamette Subbasins TMDL for May, June, September and October. The wasteload allocation and subsequent revisions to the NPDES permit would enable discharge to surface waters in May, June and September and October when weather conditions limit demand for recycled water.

Section 9.1 of the TMDL states that the "human use allowance at OAR 340-041-0028(12)(b)(B) identifies the allowed temperature increase reserved for human uses. The rule requires that wasteload and load

allocations restrict all NPDES point sources and nonpoint sources to a cumulative increase of no greater than 0.30°C (0.5°F) above the applicable criteria after complete mixing in the water body, and at the point of maximum impact.” A series of tables are included that define the source category allocations in various watersheds in the Willamette Subbasins TMDL. **Table 9-10** defines the human use allowance allocations that would apply to the City’s WWTP discharge to Tickle Creek.

Table 9-10: Human Use Allowance allocations for all other waters in the Willamette Subbasins.

Portion of Human Use Allowance (°C)	Source or source category
0.075*	NPDES point sources
0.00	Dam and reservoirs operations
0.05	Water management activities and water withdrawals
0.02	Solar loading from existing transportation corridors, existing buildings, and existing utility infrastructure
0.00	Solar loading from other nonpoint sectors
0.155	Reserve capacity
0.30	Total

Note: * NPDES permitted point sources are allowed up to 0.075°C cumulatively at the point of maximum impact. The portion of the human use allowance at the point of discharge is described in Table 9-11. If the point source

This table shows that 0.075°C has been allocated to NPDES point sources and there is significant reserve capacity (0.155°C) that is available. We recommend that DEQ include a portion of the reserve capacity to provide a wasteload allocation for the City’s WWTP. Wet weather driven surface water discharges during these periods (i.e., May, June and October) do not have much of an effect on temperature regimes in streams. A wasteload allocation in the Willamette Subbasins TMDL will provide a framework for the City to manage wastewater from the WWTP in an effective and efficient manner.

Thank you for your consideration of the City’s comments. If you have any questions, please do not hesitate to contact me.

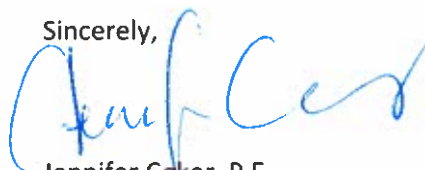
Sincerely,

 Jennifer Coker, P.E.
 Public Works Director

From: [City of Sodaville](#)
To: [TEMPERATURETMDL Willamette * DEQ](#)
Subject: TMDL Temperature Rule Public Comments
Date: Monday, January 22, 2024 12:08:23 PM

You don't often get email from sodavillecityhall@gmail.com. [Learn why this is important](#)

TMDL is a costly unfunded mandate for Oregon's municipalities that provides no utility to protecting the environment in most of the places it is mandated. If the State of Oregon is forced to regulate TMDL, it should be solely responsible for implementation and bear 100% of the costs. Any expansion of the program will be too costly for most municipalities to support, and the Commission should ask the Legislative Assembly to shift the burden to DEQ from Cities.

Alex McHaddad
Sodaville City Administrator/Recorder
30723 Sodaville Rd Lebanon, OR 97355



CITY OF TROUTDALE ENGINEERING DIVISION

Sent via Email

March 15, 2024

Michele Martin
Oregon Department of Environmental Quality
700 NE Multnomah Street, Suite 600
Portland, OR 97232
Willamette.temperatureTMDL@DEQ.oregon.gov

Dear Michele Martin,

Thank you for the opportunity to provide comments on the draft Willamette Subbasins Temperature TMDL.

General Comment

- The City of Troutdale does not discharge to the Willamette River or its subbasins and should not be included as a DMA in either the Willamette Subbasin TMDL or WQMP. Additional documentation can be provided to support this statement.
- The City supports those comments listed in ACWA's comment letter for the Draft TMDL and WQMP for the Willamette Subbasins.

Please contact me if you have any questions regarding this matter.

Sincerely,

Ryan Largura

Ryan Largura
Environmental Specialist



February 20, 2024

Michele Martin
DEQ Water Quality Division
700 NE Multnomah Street, Suite 600
Portland, Oregon 97232-4100

Sent via email to: Willamette.TemperatureTMDL@DEQ.oregon.gov and
Sandy.SubbasinTMDL@DEQ.oregon.gov

Subject: Comments on the Draft Willamette and Sandy River Watershed Temperature TMDLs

Dear Michele Martin,

Thank you for the opportunity to provide comments about the January 2024 draft temperature TMDLs for the Willamette and Sandy River watersheds.

Clackamas Water Environment Services (WES) produces clean water, protects water quality and recovers renewable resources. We do this by providing wastewater services, stormwater management, and environmental education. It's our job to protect public health and support the vitality of our communities, natural environment, and economy. We do that as a collaborative partner in building a resilient clean water future where all people benefit and rivers thrive.

WES maintains and operates:

- The Boring Sewage Treatment Plant (STP), which discharges into the North Fork of Deep Creek in the Willamette River watershed in Boring.
- The Hoodland STP, which discharges into the Sandy River in Welches.
- The public storm sewer system in portions of northwest Clackamas County in partnership with Clackamas County and the Cities of Happy Valley and Rivergrove.

WES has reviewed these two draft TMDLs and has the following comments:

Boring STP:

The January 2024 draft Willamette River TMDL includes a wasteload allocation (WLA) of 0.125 million kcal/day for the Boring STP. This draft allocation is substantially lower than the current NPDES permit limits which are based on the 2006 Willamette River TMDL. The current 2016-2021 NPDES permit for the Boring STP specifies wasteload allocations of 0.333 million kcal/day from June 16th to October 14th based on the core cold water criteria (16 C), and 0.357 million kcal/day from October 15th to June 15th based on fish spawning use (13 C). **An assessment of recent thermal loads in the STP's effluent shows that the facility would be in immediate non-compliance with the proposed WLA in the Jan. 2024 draft TMDL.** Please see the

attached Excel file with Excess Thermal Load data from the Boring STP from April 2020 through October 2023. In many instances, the 7-day average excess thermal load (ETL) discharged during this recent time period exceeds the 0.125 million kcal/day which was allocated to the Boring STP in the Jan. 2024 draft TMDL. Because this is a wastewater treatment plant which serves a community, WES does not have any available options for reducing the temperature or volume of the Boring STP's effluent. Because there is a significant amount (0.155 C) of reserve capacity available in this section of the North Fork of Deep Creek (see Table 9-10), we urge DEQ to distribute some of this reserve capacity to the Boring STP's WLA to provide an achievable WLA for the Boring STP.

In the Jan. 2024 draft Willamette TMDL's Water Quality Management Plan, it says this about WLAs for point sources: *"The allocation was increased above 0.075 when analysis indicated that 0.075 would result in immediate noncompliance. DEQ only increased the allocation if there was sufficient loading capacity available. An assessment of current thermal loading was not possible for all point sources due to project time constraints or lack of data."* It appears that DEQ hasn't yet conducted this assessment of thermal loading for the Boring STP and we urge DEQ to do this prior to finalizing the TMDL.

Also prior to finalizing the TMDL, we also encourage DEQ to establish two WLAs for the Boring STP, as was done in the 2006 Willamette TMDL. One WLA would be for the period from June 16th to October 14th and the other would be from October 15th to June 15th.

Finally, the Jan. 2024 draft Willamette TMDL says the North Fork of Deep Creek's 7Q10 flow at the Boring STP is 0.65 CFS, but WES' 2009 mixing zone study for the Boring STP says the 7Q10 flow there is 0.24 CFS, and this is the 7Q10 flow which DEQ relied upon to write portions of the Boring STP's current (2016-2021) NPDES Permit. Please evaluate this situation to be sure that DEQ is using the most appropriate 7Q10 flow in the new TMDL.

Hoodland STP:

The January 2024 draft Sandy River TMDL includes a wasteload allocation (WLA) of 23.4 million kcal/day for the Hoodland STP. This draft allocation is substantially lower than the current NPDES permit limits which are based on the 2005 Sandy River TMDL. The current 2022-2027 NPDES permit for the Hoodland STP specifies a WLA of 29.9 million kcal/day, which raises the question of why is the Hoodland STP's WLA proposed to be reduced by 6.5 million kcal/day? Is this portion of the Hoodland STP's load proposed to be given to the City of Sandy's proposed new wastewater treatment plant discharge into the Sandy River?

Please see the attached Excel file with Excess Thermal Load data from the Hoodland STP from May 2020 through October 2023. Within this set of data, the highest 7-day average ETL discharged was 7.2 million kcal/day, so a 23.4 million kcal/day allocation to the Hoodland STP in the new TMDL should be satisfactory, because it will allow for some increase in its ETL over time (due to population growth, for example) without causing noncompliance.

And finally, we're concerned about Table 9-3, which contains the Human Use Allowance for the section of the Sandy River where the Hoodland STP is located. "Warming from tributaries" is proposed to receive 0.21 C of the 0.3 C Human Use Allowance and there isn't any allocation for

Reserve Capacity. Please explain why Reserve Capacity receives no allocation. If DEQ is able to do so, we recommend that some of the very large allocation for “warming from tributaries” be re-distributed to Reserve Capacity to ensure that additional loading is available for distribution to sources in the future – potentially including the Hoodland STP if needed – in this reach of the river.

Oregon’s Water Resources Department:

Oregon’s Water Resources Department should be identified as a DMA (Designated Management Agency) in the Sandy River and Willamette River Watershed Temperature TMDLs. In Appendix A on Page #54 of #83 in the Jan. 2024 draft Willamette River TMDL’s Water Quality Management Plan, in rows #126 to #133 in the table, Oregon’s Dept. of Forestry (ODF), Oregon’s Department of Agriculture (ODA), and several other state agencies are identified as DMAs. Why was WRD omitted from this draft list?

On page #7 of #83 in the Jan. 2024 draft Willamette River TMDL’s Water Quality Management Plan, water rights and the benefit of enhancing instream flows are addressed: *“Water conservation is a best management practice that directly links the relationship between water quantity and water quality. Leaving water instream functions as a method to protect water quality from flow-related parameters of concern, such as temperature. Under state law, the first person to file for and obtain a water right on a stream is the last person to be denied water in times of low stream flows. Therefore, restoration of stream flows may require establishing instream water rights. One way this can be accomplished is by donating or purchasing out-of-stream rights and converting these rights to instream uses.”* To support attainment of the allocations in these water temperature TMDLs, the WRD could communicate with senior water rights holders, for example, to verify that they aren’t taking more water for consumptive purposes (ie. irrigating crops) than is allowed by their water right in order to maintain higher instream flows and lower instream temperatures.

Clackamas WES is a DMA:

On Page #54 of #83 in the Jan. 2024 draft Willamette River TMDL’s Water Quality Management Plan, in row #125 in the table found in Appendix A, WES’ name isn’t spelled correctly. It says *“Water and Environment Services”*. The correct name to use here is Water Environment Services.

MS4 Permits in the Jan. 2024 draft Willamette River TMDL:

- Please re-name Table 9-11, which begins on page #40. Its current title is “Point Sources” but MS4 Permits, which are point sources, have been excluded. MS4 Permits were included in Table 7-2.
- Section 9.1.2 says *“The wasteload allocation for registrants under the general stormwater permits (MS4, 1200-A, 1200-C and 1200-Z) and general permit registrants not identified in Table 9-11 is equal to any existing thermal load authorized under the current permit.”* This is problematic because we’re unsure what the existing thermal load is that was authorized by the Phase II General MS4 Permit, and a NPDES permit cannot authorize a MS4 to discharge an excess thermal load if the load isn’t first properly authorized by the temperature TMDL. Note that this phrase says only “general” MS4 permits are included. Please remember to also consider Phase I individual MS4 Permits

when addressing this subject (Clackamas WES' Phase I MS4 Permit is an individual MS4 permit).

- On page #23, the draft TMDL says *“Based on a review of published literature and other studies related to stormwater runoff and stream temperature in Oregon (see TSD section 7.1.2), DEQ found there is not sufficient evidence to demonstrate that stormwater discharges authorized under the current municipal (MS4s) permits or the construction (1200-C) and industrial (1200-A and 1200-Z) general stormwater permits contribute to exceedances of the temperature standard.”* The TMDL also says *“Waste load allocations were not assigned to storm water sources such as municipal separate storm sewer systems (MS4s) and combined sewer overflows because they have been determined not to be significant contributors to heat over a seven day period as specified in the temperature standard.”* We encourage DEQ to provide a modest temperature WLA to all MS4s in this TMDL – and also in the Sandy River TMDL – to avoid unintended compliance problems if it turns out that one or more MS4s are someday found to be a significant contributor of heat. An example could be a storm sewer system with a large stormwater treatment & detention pond near the outfall with a constant source of spring-fed flow (24-7) during the hot Summer months. In this instance, this spring water could be warmed somewhat on its way through the pond before being discharged into the creek, wetland or river.

Please do not hesitate to call me at (503) 742-4581 if you have any questions, concerns or comments.

Sincerely,



Ronald Wierenga
Deputy Director

cc Andrew Swanson (WES)







Final_WES_comment_letter_for_Jan_2024_draft_Sandy_and_Will_TMDLs

Final Audit Report

2024-02-20

Created:	2024-02-20
By:	Jeffrey Miller (JMiller@clackamas.us)
Status:	Signed
Transaction ID:	CBJCHBCAABAAGmycshZEwMbmPJCEOn1Ape2e7YdNWgCX

"Final_WES_comment_letter_for_Jan_2024_draft_Sandy_and_Will_TMDLs" History

-  Document created by Jeffrey Miller (JMiller@clackamas.us)
2024-02-20 - 9:12:47 PM GMT
-  Document emailed to rwierenga@clackamas.us for signature
2024-02-20 - 9:13:05 PM GMT
-  Email viewed by rwierenga@clackamas.us
2024-02-20 - 9:15:39 PM GMT
-  Signer rwierenga@clackamas.us entered name at signing as Ronald Wierenga
2024-02-20 - 11:15:45 PM GMT
-  Document e-signed by Ronald Wierenga (rwierenga@clackamas.us)
Signature Date: 2024-02-20 - 11:15:47 PM GMT - Time Source: server
-  Agreement completed.
2024-02-20 - 11:15:47 PM GMT

February 22, 2024

Michele Martin
DEQ Water Quality Division
700 NE Multnomah Street, Suite 600
Portland, Oregon 97232-4100

Sent via email to: Willamette.TemperatureTMDL@DEQ.oregon.gov

Subject: Clean Water Services Comments on the Draft Willamette Subbasins Temperature TMDL

Dear Michele Martin,

Thank you for the opportunity to comment on the Willamette Subbasins Total Maximum Daily Load (TMDL). CWS is a county service district located in Washington County that provides sanitary sewer service, stormwater management, and environmental restoration for more than 600,000 residents and the businesses and industries that support the local and global economy. CWS holds a watershed-based NPDES permit covering four water resource recovery facilities, the sanitary sewer conveyance system, and the municipal separate storm sewer system (MS4) that discharge to the Tualatin River. The Tualatin River is a tributary to the Willamette River; although it is not included in this TMDL, CWS is commenting on precedent-setting policies that can impact the Tualatin Basin TMDLs. CWS supports and affirms the comments made by the Oregon Association of Clean Water Agencies regarding the impact on the Willamette Subbasins TMDL to point sources and permittees of the National Pollutant Discharge Elimination System.

CWS recommends that the Oregon DEQ include processes that continue to allow for thermal load trading in the TMDL along with a clear statement supporting trading as allowed by rule (and cited in OAR 340-039-0005) in the Willamette Subbasins TMDL. Clean Water Services is concerned that the way the human use allowance (HUA) was allocated in the Willamette Subbasins TMDL may be read to limit the ability of point sources to create or continue water quality trading programs. The temperature TMDL is allocating thermal loads and using shade as a surrogate for nonpoint sources. The draft Willamette Subbasins TMDL allocates no portion of the HUA to nonpoint sources, except existing transportation corridors, buildings, and utility infrastructure. The DEQ should enunciate how thermal load trading would work and if a portion of the nonpoint source shade estimates, gap analysis, or HUA should be reserved for point source trading.

CWS began implementing a thermal load management program (referred to originally as the Temperature Management Plan) when the first watershed-based NPDES permit was issued in 2004. The permit includes thermal load limits for CWS' water resource recovery facilities (WRRFs) at Rock Creek, Durham, and Forest Grove and the Natural Treatment System (NTS) based on the 2001 Temperature TMDL for the Tualatin River. The permit allows CWS to offset the thermal loads from the Rock Creek, Durham, and Forest Grove WRRFs and the NTS by implementing a water quality credit trading program for temperature. The program includes flow enhancement and riparian planting as specified in Schedule D.10. of the NPDES permit and CWS' DEQ-approved Thermal Load Management Plan (TLMP). Much of the information to specify CWS' methodology for calculating the thermal credits associated with the riparian planting and flow enhancement programs is in the TLMP and the associated annual reports which DEQ receives and reviews. A brief description is provided here.

Flow Enhancement Program

CWS' flow enhancement program consists of releasing cool stored water from Hagg Lake and Barney Reservoir from May through November. CWS also releases cool stored water from Barney Reservoir and Hagg Lake and conversion of instream water rights to McKay, West Fork Dairy, East Fork Dairy, and Gales creeks during the summertime to enhance stream flows in those tributaries. Annually, CWS releases an average of 45 cfs (29 MGD) of water from Barney Reservoir and Hagg Lake in July and August to enhance stream flows and improve water quality in the Tualatin River and its tributaries.

Riparian Planting Program

CWS implements a riparian planting program as part of its water quality credit trading program for temperature. As noted in the 2001 TMDL, solar radiation is a significant component of the overall thermal energy input into the Tualatin River Watershed.

CWS funds landowner incentive programs that enroll agricultural lands in riparian shade programs. The landowner incentive programs, the Enhanced Conservation Reserve Enhancement Program (ECREP) and Vegetated Buffer Areas for Conservation (VEGBAC) programs, are implemented by the Tualatin Soil and Water Conservation District (TSWCD) in coordination with the Natural Resources Conservation Service (NRCS) and Farm Service Agency (FSA) for Washington County.

Since establishing the trading program in 2004, CWS has implemented 195 planting projects along streams in the Tualatin River Watershed that have generated over 614 million kcal/day of thermal credit and restored nearly 98 stream miles of riparian vegetation spanning both urban and rural areas. Shade provided by these riparian planting projects helps block potential solar load (sunlight) from warming streams. To date, more than 1,227,500,000 kilocalories per day of solar load have been blocked by the nearly 200 projects implemented.

Additional Benefits

CWS' water quality credit trading program provides numerous benefits beyond temperature benefits. Ecosystem benefits include improved stream functions (e.g., floodplain roughness, bank stabilization, peak flow attenuation, habitat creation), increased diversity of aquatic and terrestrial plant and animal species, filtering of stormwater runoff, and improved water quality. The increased complexity of structure and diversity of restored riparian forests, forested wetlands, and scrub-shrub wetlands support many important ecosystem functions for the aquatic environment.

CWS has quantified the water quality benefits associated with sediment and nutrient reduction from the riparian planting program. The riparian planting projects enrolled in CWS' water quality trading program are estimated to remove approximately 1,316,000 pounds of sediment, 10,300 pounds of total nitrogen, and 18,000 pounds of phosphorus each year that would otherwise be released to streams in the Tualatin Basin. These estimated load reductions are based on a 2014 study on nutrient and sediment removal rates for stream restoration projects in the Chesapeake Bay. The Chesapeake Bay study provides a wide range of sediment and nutrient removal reduction for stream restoration projects. CWS' release of stored water flow enhancement provides cooling effects, buffers against temperature changes, and results in higher dissolved oxygen levels and improved overall water quality to support aquatic life.

Adaptive Management

CWS' TLMP is designed to adjust adaptively to future climate regimes in the Tualatin Basin. CWS is adjusting elements of riparian planting plans and pallets to account for changes in growing seasons and the suitability of plant species as a result of climate change. The restoration of riparian areas, along with

cold water enhancement to tributaries, are important strategies to increase climate resiliency and provide water quality benefits beyond lowering temperatures during critical migration and spawning periods.

Conclusion and Recommendations

DEQ should be explicit about the role of water quality trading as defined in Oregon Administrative Rules as a compliance option, and a portion of the nonpoint source shade estimates or human use allowance to solar loading from nonpoint sources other than existing transportation corridors, buildings and utility infrastructure should be reserved for WQ Trading with Point Sources. WQ Trading is one of the most efficient and effective tools for offsetting thermal loads from point sources, and it provides environmental benefits that extend into the watershed.

Please contact me if Clean Water Services can provide any additional information.

Sincerely,



Robert P. Baumgartner
Director, Regulatory Affairs



REGION 10
SEATTLE, WA 98101

March 14, 2024

Ms. Michele Martin
Oregon Department of Environmental Quality
Water Quality Program
700 NE Multnomah Street, Suite 600
Portland, Oregon 97232
Willamette.TemperatureTMDL@DEQ.oregon.gov

Re: EPA Comments on the Willamette Subbasins Temperature TMDL

Dear Michele:

The U.S. Environmental Protection Agency has reviewed the Oregon Department of Environmental Quality's Willamette Subbasins Temperature TMDL, which was released for public comment on January 10, 2024. The public comment period was initially scheduled to end February 23, 2024, but was extended until March 15, 2024. The EPA's comments on the TMDL report are listed below.

1. Although the TMDL identifies waterbody names in the captions of the Human Use Allowance (HUA) allocation tables (Tables 9-1 through 9-9), because the TMDL addresses 236 impaired assessment units (AUs) and 677 unlisted or unassessed AUs, the EPA requests that ODEQ explicitly identify within the TMDL or Technical Support Document (TSD) the HUA allocations assigned to each assessment unit (AU). One potential solution is to identify the associated HUA allocation table for each AU listed in Appendix D.
2. Figures 4-1 and 4-2 broadly show fish use designations and the applicable timing of spawning use designations at the project area scale, but it is difficult to discern the applicable year-round and spawning criteria and associated timing of each for the AUs addressed in the TMDL; this information is needed to calculate the loading capacity using Equation 8-1 and background and nonpoint source allocations for each AU using Equations 9-2 and 9-3, respectively. The EPA requests that ODEQ add information to the TMDL or TSD identifying the applicable year-round and spawning criteria and associated timing for each of the impaired AUs addressed in the TMDL.
3. To assist in the EPA's review of the wasteload allocations to point sources, the EPA requests that ODEQ identify the AU ID of the receiving water (or nearest downstream AU) for point sources assigned a numeric wasteload allocation and add a figure to the TMDL, TSD, or associated appendices showing the value and applicable location of point source HUA allocations identified in Tables 9-1/9-2 of the TSD.

4. Neither the TMDL nor the TSD show the calculated nonpoint source load allocation(s) using Equation 9-3 for any of the impaired AUs or include a non-conceptual example showing the TMDL elements and surrogates in one place. The EPA requests that ODEQ add at least one example calculation for an impaired waterbody showing the daily load capacity and all associated wasteload allocations, load allocations, and surrogates, as well as the supporting information needed to calculate each component (e.g., flow, applicable criteria, HUA allocations). This could include a reference to existing information for the load capacity, wasteload allocation, background load allocation, and surrogates.
5. The EPA has noted some discrepancies between the text and tables or figures and requests clarification from ODEQ on these items: 1) p. 41 of the TSD indicates monitoring sites with the longest period of exceedance of applicable temperature criteria were used to identify the TMDL critical period for each subbasin and cites the Middle Willamette (Figure 5-16) as having exceedances starting in April, however, May 1 is identified as the start of the critical period for all waterbodies of the Middle Willamette Subbasin; and 2) The following facilities listed in Table 6-3 of the TSD have no receiving stream identified or have a receiving water listed as unknown, but have receiving waters listed in Table 7-3: 108298, 103774, 65610, 103832, and 110603.

We appreciate ODEQ's extensive work on this TMDL as ODEQ works towards meeting court-ordered deadlines for the Temperature TMDL Replacement project. The EPA also appreciates the opportunity to work with ODEQ and looks forward to continued coordination as you finalize this TMDL report. If you would like to discuss these comments, you can reach Lisa Kusnierz of my staff at 208-378-5626 or Kusnierz.Lisa@epa.gov or me at 206-553-6328 or Wu.Jennifer@epa.gov.

Sincerely,

JENNIFER
WU

Digitally signed by
JENNIFER WU
Date: 2024.03.14
11:17:29 -07'00'

Jenny Wu
Watersheds Section Manager
Water Division



Eugene Water & Electric Board

4200 Roosevelt Blvd.
Eugene, OR 97402-6520
541-685-7000
www.eweb.org

March 12th, 2024

Oregon Department of Environmental Quality
Attn: Michele Martin, Water Quality
700 NE Multnomah Street, Suite 600
Portland, Oregon 97232-4100

Subject: Draft Temperature Total Maximum Daily Load for the Willamette Basin

To Whom it May Concern:

Thank you very much for the opportunity to comment on the draft Total Maximum Daily Loads (TMDLs) for the Willamette Subbasins: Temperature, dated January 2024. The Eugene Water & Electric Board (EWEB) is a customer-owned public utility providing clean and reliable electricity and water to the citizens of Eugene, Oregon and surrounding areas. EWEB owns and operates numerous hydroelectric projects along the McKenzie River. In the draft Temperature TMDL document, EWEB has been named a Designated Management Agency by the Oregon Department of Environmental Quality (DEQ) due to our National Pollutant Discharge Elimination System (NPDES) permits for our hydroelectric and water treatment facilities as well as our management of reservoirs within the McKenzie Subbasin.

The DEQ's draft TMDL assigns EWEB an allocation of the Human Use Allowance for the Walterville Hydroelectric Project and a zero allocation for the Leaburg Project. EWEB disagrees with the parts of the draft Willamette Temperature TMDL that have the potential to impact operations at Leaburg and Walterville. First, DEQ fails to recognize federal preemption by the Federal Energy Regulatory Commission (FERC) license and relicensing proceeding for the Leaburg and Walterville Projects. The FERC license establishes instream flow requirements for the Projects along with other measures to mitigate for project impacts to the environment. Water quality impacts from hydroelectric projects are addressed through the Section 401-Certification process, which provides DEQ an opportunity to incorporate TMDL temperature allocations during the FERC licensing process. Once the FERC license is issued, it controls operations of the hydroelectric project. EWEB's Leaburg and Walterville Projects do not have a Section 401-Certification because the DEQ failed to act on EWEB's 401 application within the statutory one-year time period.

Furthermore, the issues concerning flow and temperature impacts related to the Leaburg and Walterville projects were previously contested and decided as part of the FERC licensing process. Both the DEQ and the Oregon Department of Fish and Wildlife participated in the FERC licensing process and the Ninth Circuit Court of Appeals review of the FERC order. Thus, the FERC licensing decisions and subsequent judicial review of those decisions preclude new temperature limitations or controls from being implemented at Leaburg and Walterville.



Eugene Water & Electric Board

4200 Roosevelt Blvd.
Eugene, OR 97402-6520
541-685-7000
www.eweb.org

Finally, EWEB withdraws water for the Leaburg and Walterville projects from the McKenzie River pursuant to EWEB's water rights established under Oregon law. Neither state nor federal TMDL laws authorize the DEQ to regulate water withdrawals. EWEB believes that the DEQ's attempt to regulate water withdrawals for the Leaburg and Walterville Projects through a TMDL allocation is outside the scope of the DEQ's discretion. DEQ's authority under state and federal TMDL laws only extends to regulating sources that introduce pollutants to the receiving stream. The federal Clean Water Act does not provide the authority to regulate flow and the DEQ lacks the state jurisdiction to regulate withdrawals.

EWEB remains committed to being a good steward of the environment. The McKenzie River is the sole source of Eugene's drinking water and for many years EWEB has been a leader in the state, and even the nation, for our Source Water Protection Program. If asked by the DEQ to develop a TMDL Implementation Plan for temperature, we will highlight our ongoing and planned efforts to enhance and protect riparian areas along the McKenzie, establish side channels for the benefit of threatened and endangered aquatic species, and address water quality concerns to the extent that we are able. We will make every attempt to comply with the wasteload allocations for temperature that will be incorporated into our NPDES permits for the Carmen Smith and Trail Bridge powerhouses. We will continue to partner with the McKenzie Watershed Council, and other members of the Pure Water Partnership, to improve water quality throughout the Basin. However, the Leaburg and Walterville projects are governed by a FERC license that provides the only mechanism for addressing project-related temperature impacts.

Respectfully,

Lisa Krentz
Generation Manager
Eugene Water & Electric Board



Springfield Mill
801 42nd Street
Springfield, OR 97478

T 541-741-5700
F 541-741-5200

Submitted by E-Mail to: Willamette.TemperatureTMDL@DEQ.oregon.gov

March 14, 2024

Attn: Michele Martin
Oregon DEQ, Water Quality
700 NE Multnomah Street, Suite 600
Portland, Oregon 97232-4100

**RE: INTERNATIONAL PAPER COMPANY COMMENTS ON TEMPERATURE
TMDL FOR THE WILLAMETTE SUBBASINS and THE McKENZIE RIVER,**

Dear Ms. Martin:

On November 30, 2023, Oregon DEQ invited International Paper Company (IP) to meet with DEQ regarding potential temperature waste load allocations for the IP Springfield Mill. At a meeting between the parties on December 13, 2023, DEQ informed IP that the McKenzie River, and therefore the IP Springfield Mill's discharges, were being included in the Willamette Subbasin TMDL. This was a surprise as it had been IP's understanding that the McKenzie River temperature allocations would be addressed in the Willamette River Mainstem and Major Tributaries TMDL that is scheduled to begin in 2024. As a permitted discharger to the McKenzie River, IP submits the following comments on the "Temperature TMDL for The Willamette Subbasins" and the McKenzie River.

Comment 1 - Grab sample temperature data used in the TMDL modeling and allocation process will underestimate the energy discharges of IP's Springfield Mill

Temperature data used by DEQ in TMDL modeling exercises was collected using historical practices for NPDES reporting. The IP Springfield Mill's discharge permit requires that temperature data be obtained from grab samples taken only 3 times per week. The grab samples are typically taken during morning rounds. These measurements accurately represent the temperature of the effluent at the time they are taken and this procedure has been adequate for regulatory purposes. However, continuous temperature measurements installed after the 2006 TMDL was issued, have identified a summertime bias in the historical data for the outfalls of the mill. As such, we submit that the daily temperature average should be used for determining temperature loading allocations.

ASBs are large open bodies of water and they receive significant solar input during warm days. Cooling ponds are shallow open bodies of water that also receive solar input, reducing the amount of cooling that can occur during warm days. Like the river, this solar heat input elevates the ASB and cooling pond temperature during the day causing it to reach a maximum temperature in the late afternoon and then dropping in temperature through the night. Outfall minimum temperatures in this diurnal cycle are achieved in the early morning precisely when the IP Springfield Mill has historically taken the grab samples. The result is a significant bias in the measurement of average and/or maximum temperatures and, therefore, the thermal energy associated with these discharges. Therefore, the quantities of energy discharged during the summer by our mill outfalls has been significantly underestimated in DEQ's analysis and have resulted in the mill's allocations being set too low.

DEQ has indicated to IP that compliance limits and monitoring will be implemented based on maximum effluent temperatures observed each day because the water quality standard is based upon maximum temperatures. However, the model data used was 3-day per week morning grab temperatures. Because the grab sample data is used to derive the heat load limits, morning grab temperatures should similarly be required to demonstrate compliance with any future permit limits issued for IP under this TMDL.

Additionally, daily heat load calculations using maximum effluent temperatures overestimate the heat load used for permit compliance calculations. While the daily maximum temperature may be an appropriate way to develop a water quality standard, it is an improper method to calculate a total heat input from a permitted source. The heat load to the river must be calculated using the average daily temperature from a source to determine the *actual heat load* supplied by the source to the river and to determine compliance with any waste load allocation (WLA) assigned to the source.

Comment 2 – Allocation of individual source Allowable Heat Load is within DEQ's discretion.

International Paper acknowledges that DEQ has the discretion to set individual WLAs based on consistent and equitable policy considerations. International Paper Springfield recognizes that being located on a tributary of the Willamette offers special challenges. The current WLA that International Paper Springfield has in the draft TMDL is significantly lower than historical thermal discharges from the mill and will be a major challenge to meet even with significant capital expenditure.

DEQ can assign different allocations for different portions of the river up to the maximum Human Use Allowance of 0.30°C. IP urges DEQ to approve an allocation of 0.20 for the September through October Spawning Period for the Springfield Mill. Such an allocation is protective of the water quality standard. The proposed allocation of 0.18 in the Spawning Period and 0.20 in the Rearing Period will require significant capital expenditure for the Mill. Installation of cooling water collection pumping and cooling equipment such as cooling tower(s) are estimated to cost approximately one million dollars and could take years to install, with no guarantee that the

proposed WLA could be achieved. As such, IP respectfully requests that the allocation for the Spawning period be increased to 0.20 from the proposed 0.18. IP also requests that the Summer Rearing Period WLA be increased to 0.22 from the proposed 0.20 for the Mill outfalls based under calculation of IP's potential heat load as noted in Comment 1 above.

Comment 3 – Proposed Allocation for Outfall 003 is inadequate to allow any use of this Outfall.

International Paper Springfield also recognizes that the Irving Slough into which Outfall 003 flows is a unique tributary of the Willamette River that offers special challenges in the TMDL. Irving Slough is a city stormwater ditch in the wintertime that was originally part of an irrigation district. In the Rearing and Spawning periods of the year, there is essentially no stormwater flow in this Slough. The only water that allows the ponds and wetland areas of North Springfield to not be completely dry in the summer is non-contact cooling water that is discharged from International Paper's Outfall 003.

The WLA that DEQ has proposed for Outfall 003 in the draft TMDL is orders of magnitude lower than historical discharges. The significantly reduced proposed allocation will, in essence, eliminate the ability to discharge any flow at Outfall 003 if finalized in the TMDL. The proposed WLA requires that Outfall 003 be discharged at the Spawning and Rearing temperature standards at any time there is discharge to the Irving Slough.

There is strong support for Outfall 003 by the city and the community along the Slough because it feeds water to the ponds, riparian zones, and wetlands of the Irving Slough system during the summer months. Without this discharge, the Irving Slough system will be completely dry during the summer months. The DEQ has previously recognized value to the community in continuing to permit Outfall 003. The relatively low flow of 003 (1 to ~5 MGD) and its long reach, approximately 8 miles, allow for a high degree of heat loss prior to discharge to the Willamette Mainstem. This is because the long travel time in the Irving Slough conveyance allows much more heat loss when compared to the retention time in our on-site cooling ponds.

The elimination of the Outfall 003 discharge requires that the water from 003 be redirected into our McKenzie outfalls 001 and/or 002. The net heat load to these outfalls will thereby increase, so the WLA increases requested in Comment 2 must be granted to help offset the DEQ requirement to essentially eliminate 003.

Comment 4 – The proposed Willamette Subbasins TMDL does not have an allocation for IP's 200-J Permit identified in Table 7-3.

The TMDL Document clearly identifies that International Paper has a 200-J Filter Backwash Discharge Permit in Table 7-3. All other 200-J permits identified in that table are given thermal allocations (WLA) in Table 9-11 of the Draft TMDL. However, IP's 200-J permit is not included in Table 9-11 allocations to permit holders. As such, DEQ has inequitably denied a WLA to the

IP Outfall associated with IP's 200-J permit, unlike all the other 200-J Permits identified in Table 7-3 which received WLAs. It is inequitable for DEQ to deny a thermal load allocation to IP's 200-J Permit in this TMDL. Based upon other allocations for 200-J permits in Table 9-11, IP requests that DEQ provide this discharge a WLA consistent with similar permits.

Comment 5 – The proposed Willamette Subbasins TMDL does not properly address variable meteorological conditions.

DEQ based the Willamette Subbasins TMDL modeling on the meteorological conditions experienced in the Willamette Valley in 2015. Attachment 1 is a sample of the meteorological data available for the Willamette Valley. This particular example contains historical monthly average maximum temperatures air temperatures in Eugene by month. Please refer to the colored sections of this data set. The sections that indicate the meteorological period DEQ chose to base the temperature TMDL are highlighted in yellow (2015 Spawning and Rearing seasons).

Of particular concern to International Paper are the shoulder seasons, May and September-October. Please note the blue and orange shaded areas highlighting the maximum and minimum monthly average maximum temperatures for this data set. The average maximum temperature in Eugene in October for the month (2015) on which DEQ based the TMDL was 70.5°F. The historical range in this data set for October is from 59 to 72°F, 1984 and 2022 respectively.

The river temperatures experienced in October of 1984 and 2022 were clearly significantly different from 2015. The 2015 river temperature upstream of Springfield was 50.1°F compared to the 2022 temperature of 51.5°F (See Attachment 2). To base October WLAs on simulations using only October of 2015 meteorological conditions is much less than robust and introduces errors and uncertainty into the TMDL.

Similarly, the river temperatures experienced in May of 1991 and 1992 had to be significantly different from 2015. The 1991 ambient maximum temperature was 61.4°F while the 1992 temperature was 74.7°F. The May 2015 maximum temperature of 70.2°F is substantially different. To base TMDL WLAs on simulations using only 2015 meteorological conditions introduces errors and uncertainty into the TMDL and the WLAs. International Paper appreciates the difficulty of addressing this complexity but having a TMDL with restrictive temperature limits without a thorough variability analysis from modeling the extremes can result in unattainable WLAs. International Paper urges DEQ to modify this overly conservative modeling and increase the WLAs as requested in Comment 2 above.

Comment 6 – The proposed 7Q10 WLA for the Spring Season contains an incorrect number.

The Spring Season 7Q10 WLA in Table 9-11 shows a WLA of 730.418E+6 kcals/day for the May 1 to June 15 time period. The equation for the WLA calculates to 730.518 kcals/day based

Ms. Michele Martin

March 14, 2024

Page 5

upon the 7Q10 McKenzie River flow rate of 2,459 cfs. This appears to be a typo that requires correction.

If you have any questions about these comments, please call me at 541-741-5752 or e-mail me at brian.brazil@ipaper.com.

Sincerely,

A handwritten signature in purple ink, appearing to read "B. Brazil", is placed on a light yellow rectangular background.

Brian Brazil
Environmental Manager
Springfield Mill

Enclosures

c: Environmental Files

Attachment 1. EUGENE: Monthly & Annual Average MAXIMUM Temperatures

Year	Jan	Feb	Mar	Apr	May	Jun	Jul	Aug	Sep	Oct	Nov	Dec	Annual
1976	49.3	50.6	54	59.6	68.4	73.1	84.6	78.5	78	67.9	55.3	44.5	63.7
1977	49	54.2	54.7	64.7	62.7	75.9	80.2	84.9	71.1	63.5	51.4	48.6	63.5
1978	47.5	50.8	59.8	57.5	65.3	75.8	82.3	80.5	70.9	67.3	48.7	42.8	62.5
1979	38.2	48.7	58.9	60.1	69.2	76.7	84.6	79.9	77.2	67.5	49.3	49.8	63.4
1980	43.5	51.1	54.4	62.6	65.5	68.4	81.7	80.1	77.5	67.6	54.6	49.3	63.1
1981	46.8	51.4	56.2	60.9	65.5	71.5	80.2	84.9	77.4	61.7	53.1	47.7	63.2
1982	42	49.6	54	58.4	68	74.4	78.1	81.5	74.4	63.5	49.5	45.2	61.6
1983	48.8	51.9	55.8	61.5	68.3	70.4	74.7	79.8	73	62.9	52.6	41.4	61.8
1984	48.3	52.3	57.8	57.1	64.5	70.3	82.3	81.2	75.6	59.4	50.3	43.4	61.9
1985	41.3	50.1	53.6	63.2	68.1	76.4	87.3	81	70.9	63	44.5	39.7	61.6
1986	50	50.5	59.9	58.6	66.2	76.1	76.5	86.2	70.1	65.3	53.2	46.3	63.3
1987	46.3	51.9	56.8	64.8	69.8	78.5	76.1	84.1	77.3	72.1	53.7	44.4	64.7
1988	44.5	52.7	57.4	61	65	72.6	83.2	83.1	79.2	67.9	52.7	46.7	63.9
1989	48.6	44.2	54.7	66.6	67.5	75.3	77.7	80	81.2	65.3	55.2	46.5	63.7
1990	48.6	48.9	58.7	64.7	65.8	72.6	86	82.8	78.4	62.5	54.4	41	63.8
1991	46.4	56.7	53.3	57.7	61.4	68	82.8	82.2	82.4	68.3	54.4	46.3	63.3
1992	50.9	55.8	62	63.9	74.7	78.8	82.8	85.6	76.6	65.9	52.1	45	66.2
1993	42.2	46.5	57.7	59.2	69.6	71.8	74.5	80.5	79.6	68.8	47.7	44.5	62
1994	49.2	49.7	59.4	63.4	69.7	73.4	86.5	82.2	79.4	65.3	50	48.6	64.8
1995	50.6	56.1	58	60.5	69.7	73.3	82.6	80.8	77.7	62.3	56.9	48	64.8
1996	47.2	50.3	56.6	62.1	63.1	73.6	86.7	84	71.3	62.1	52.4	48.1	63.4
1997	47.2	50.4	55.5	59.6	72.2	71.5	81.8	84.4	77.7	59.5	54	44.9	63.1
1998	49.9	52.5	56	60.9	61.6	71.3	84.1	85.7	80.8	62.9	53.3	45.3	63.8
1999	47.9	49.8	52.2	60.6	63.1	70.6	79.7	80.1	80.5	66.9	56.6	46.6	62.9
2000	45.3	49.8	54.3	62.3	65.5	76.8	80.2	81.3	76.1	64.3	49.1	46.7	62.7
2001	47.8	50	56.1	57.8	70.8	70.8	80.9	82.5	79.2	63.8	54	46.8	63.5
2002	46.9	53.3	52.8	60.6	64.9	74.1	84.5	83.5	77.4	64.6	54.6	48.9	63.9
2003	50.7	50.9	56.4	57.4	65.9	76.7	87.3	83.4	79.1	66.4	49.8	47.7	64.4
2004	46.1	50.9	60.3	64.5	67.2	75	86	84.8	72	63.5	50.7	48	64.1
2005	48.9	51	60.3	60.2	67.3	70.3	84	86.6	76.3	63.8	49	44.5	63.6
2006	49.1	50	52.4	61.2	68.2	74.6	85	82.9	79.2	65	52.4	45.5	63.9
2007	45.5	50.5	59.2	60.3	67	72.7	83.1	81.1	74.6	60.1	50.1	45.3	62.5
2008	42.6	50.9	52	56.6	66.6	71.9	83.8	82	78.3	63	54.5	44.5	62.3
2009	46.1	50.1	52.3	59.7	68.9	73.8	86	82.3	77.5	62.1	53.2	42.4	62.9
2010	51.2	53.9	55.2	58.9	63.2	69.8	82.9	82.3	74.7	63.2	51.7	48.5	63
2011	48.4	48.2	53.9	55.9	62.1	70.2	78.3	83.2	81.5	63.4	52.3	44.7	61.9
2012	48.6	50.3	52.1	61.4	66.7	70.6	80.5	85.2	80.2	65.9	54.4	47.5	63.7
2013	42.2	50.4	58	62.6	70	77	87.2	83.5	73.6	61.7	51.9	40.7	63.3
2014	46.1	48.3	58.8	63.4	71.1	74.9	87.5	87.8	80.9	70.1	52.4	50	66.1
2015	50.7	56.9	62.6	62	70.2	83.6	88.2	85.8	77	70.5	52.4	49	67.5
2016	48.7	55.9	57.7	66.9	70.9	78.3	81.9	87.5	76.8	62.7	57.9	42.5	65.6
2017	42.7	49.6	54.9	59.1	69.2	74.3	84.7	86.8	77.2	63.4	52.5	44.4	63.3
2018	49.7	49.7	53.4	59.8	69.5	75.5	87.4	85.2	77.1	68.3	55.2	48.9	65.1
2019	50	44	56.3	62.1	70.9	78.6	82.5	85	72.8	61.4	53.2	48.2	63.9
2020	51.9	51.6	55.8	65.1	69.4	74.2	84.8	86.2	78.1	66.3	54.2	49.7	65.7
2021	50.9	50	56.2	67.6	71	82.4	88.9	86.5	79.1	62.5	56.4	46.6	66.6
2022	49.1	51.8	58.2	58.2	64.8	74.6	87.1	88.3	80.1	72.3	50.2	46.9	65.2
Average	47.31	50.95	56.31	61.12	67.37	74.06	82.97	83.36	76.96	64.84	52.51	46.01	63.72
Minimum	38.2	44	52	55.9	61.4	68	74.5	78.5	70.1	59.4	44.5	39.7	61.6
Maximum	51.9	56.9	62.6	67.6	74.7	83.6	88.9	88.3	82.4	72.3	57.9	50	67.5

Year Used for Modeling TMDL Impacts

Lowest Maximum Monthly Temperature

Highest Maximum Monthly Temperature

Attachment 2.

YEAR	Monthly mean in deg C (Calculation Period: 2010-01-01 -> 2022-12-31)											
	Period-of-record for statistical calculation restricted by user											
	Jan	Feb	Mar	Apr	May	Jun	Jul	Aug	Sep	Oct	Nov	Dec
2010	6.03	6.22	6.57	7.27	8.42	9.88	12.72	12.65	11.05	10.21	7.19	5.96
2011	5.37	5.13	5.92	6.56	7.67	9.2	11.54	12.65	10.79	9.85	7	4.51
2012	5.25	5.36	5.41	6.7	8.31	9.82	12.23	12.64	10.69	9.66	7.57	5.95
2013	4.54	5.47	6.42	7.22	9.32	11.23	13.13	12.61	10.93	9.37	6.86	4.03
2014	4.85	5.36	6.64	7.85	9.61	11.09	12.81	12.31	11.64	10.6	7.73	7.03
2015	6.08	6.82	7.54	8.45	10.59	13.24	14.03	13.97	11.96	10.07	7.74	6.56
2016	5.63	6.34	6.59	8.39	9.93	11.82	13.31	13.42	12.04	10	8.41	5.55
2017	4.27	5.55	6.08	7.1	8.79	10.86	12.95	12.34	10.55	9.12	7.28	5.28
2018	6.1	5.38	6.01	7.19	9.85	10.82	13	14.03	10.89	8.95	7.17	5.9
2019	5.65	4.76	5.84	7.28	9.33	11.52	13.05	13.29	11.57	8.63	6.84	5.72
2020	5.81	5.76	6.4	8.01	9.31	11.19	13.24	13.47	10.87	10.52	7.26	5.97
2021	6.08	5.9	6.52	8.25	9.98	12	14.76	14.35	11.37	9.97	8.17	6.27
2022	5.31	5.36	6.65	7.04	8.13	10.26	13.57	13.81	11.52	10.83	6.59	5.07
Mean of monthly water Temperature	5.5	5.6	6.4	7.5	9.2	11	13.1	13.2	11.2	9.8	7.4	5.7

From: [PETERSON Zachary J](#)
To: [TEMPERATURETMDL Willamette * DEQ](#)
Cc: [PAPPAGALLO Mauria](#)
Subject: Public Comment - Draft Willamette Subbasins Temperature TMDL
Date: Friday, March 15, 2024 3:18:46 PM

You don't often get email from zachary.peterson@lanecountyor.gov. [Learn why this is important](#)

Oregon Department of Environmental Quality Staff,

Lane County would like to submit the comments below for the Draft Willamette Subbasins Temperature TMDL Public Comment period:

- Table 7 of the Draft Water Quality Management Plan states DMAs have 18 months after EQC adoption of the Willamette Mainstem TMDL to provide an updated Implementation Plan, complete a streamside evaluation, and submit a project plan and description of the assessment methodology to be used to complete a shade gap analysis. Lane County would like to suggest revising this language to allow DMAs to propose DMA-specific timelines to accomplish these tasks with approval from DEQ. The workload involved in completing these tasks could vary greatly between DMAs; for example, Appendix A notes that some DMAs have as little as 0.1 acres of land under their jurisdiction control within 150ft of a stream while others have as high as 549,814 acres under their jurisdictional control within 150ft of a stream. Further, as noted in section 5.3 of the TMDL, OAR 340-042-0080 states that DMAs identified in a WQMP as responsible for revising implementation plans must provide a timeline for implementing management strategies and a schedule for completing measurable milestones, suggesting variability in the time required for DMAs to accomplish specific strategies. Allowing DMAs to propose and justify their own timelines (with approval from DEQ) could enhance compliance and allow DMAs to address the fundamental goals of the TMDL in a more thoughtful and complete manner based on the level of effort required by the DMA.
- Section 5.3.2 of the Draft Water Quality Management Plan states DMAs required to submit an implementation plan must complete a streamside evaluation and account for shade gap analysis results in their streamside evaluation. Section 5.3.4.1 states if DEQ has provided a shade gap analysis for a jurisdiction, the DMAs must either use DEQ's analysis to inform their streamside evaluation, or location specific methods to assess the current effective shade within the jurisdiction. Per a recent meeting among DEQ and RAC members for the Mainstem TMDL, staff were informed that DEQ used a desktop analysis method to complete shade gap analyses for various DMAs. In order to better clarify expectations of DMAs and streamline compliance toward the fundamental goals of the TMDL, Lane County would like to ask DEQ to consider development of publicly-available spatial analysis tools that would allow DMAs to complete streamside

evaluations and shade gap analyses using similar techniques to those used by DEQ, allowing DMAs to use alternative techniques if they choose to do so. This would not only assist DMAs in compliance with the TMDL and decrease timelines to strategy implementation, but could also provide more consistency among data provided to DEQ and provide a clearer picture of implementation efforts across the TMDL area. If spatial analysis tools are not able to be developed, Lane County would like to ask DEQ to consider developing procedural manuals for streamside evaluations and shade gap analyses that would provide examples of how these activities could be completed, both remotely or in the field. This would allow DMAs to have a better understanding of resource needs for accomplishing tasks (e.g., ordering specialized equipment, hiring consultants) and provide more accurate estimates of timelines to accomplish the tasks.

We greatly appreciate your consideration of these comments.

Kind regards,

Zach Peterson

Stormwater Coordinator
Lane County Public Works
3040 N Delta Hwy
Eugene, OR 97408
Office/Cell: 541-682-6759

From: Clinton Cheney
To: TEMPERATURETMDL Willamette * DEQ
Subject: Draft Temperature TMDL Public Comment
Date: Thursday, January 25, 2024 1:26:16 PM
Attachments: image004.png
image005.png
image006.png
image007.png
DMR September 2017.xlsm
Lowell Effluent Flow Record September 19 2017.pdf
Civil West DMR Review.xlsx

You don't often get email from ccheney@civilwest.net. [Learn why this is important](#)

Hello,

Regarding Table 9-11 in the Draft TMDL, the flowrate used for the Lowell STP (51477:OR0020044) is the result of a clerical error and does not accurately reflect the City's maximum thermal-WLA-season flowrate. The actual flowrate for the date in question (September 22, 2017) was 0.051 MGD (or 0.095 cfs). The email chain attached to this comment email contains my prior communication with members of the temperature TMDL development team discussing this issue.

In summary, the "1.96" number that was reported is actually a reading from the City's flow totalizer (total millions of gallons since the unit was installed), not the daily flowrate. The City's DMR worksheet containing the error is attached as "DMR September 2017.xlsm". The calculation for 24hr flow in the "Data input" tab contains a typo for the 9/22/2017 date – the previous day totalizer volume was not subtracted to calculate a 24-hour flowrate. Also attached as "Lowell Effluent Flow Record September 19 2017.pdf" is a scan of the facility's flow record wheel from that date range. This record agrees with the recalculated flowrate of 0.051 MGD.

As the City of Lowell's Engineer of Record, I am currently working on an update of the City's wastewater facility plan. As part of this process, I evaluated the facility's DMRs from January 2018 to June 2023. During this date range, the maximum flow during the proposed WLA period of 5/1 to 11/15 was 0.792 MGD occurring on 11/10/2021. A copy of the file containing these data is included as attachment "Civil West DMR Review.xlsx". While this date range is not a perfect overlap of the 2015-2019 date range used in DEQ's analysis, I am confident that if the erroneous data point was removed/corrected in DEQ's dataset that a similar max daily flow would be determined.

I am aware that changing the flowrate in this table will not have a major impact on the calculated WLA for the facility in question given the comparatively large flow from the Dexter Dam penstocks. However, it is not in the best interest of the City or DEQ for an erroneous flowrate to be included on an official rule.

I am happy to provide additional information or answer any questions,

Clinton Cheney, MS, PE
Project Manager
Professionally Licensed in Oregon (#093044)
d 541.982.4118 | c 541.290.7068



Civil West Engineering Services, Inc.
200 Ferry St. SW, Albany, OR 97321
www.civilwest.com

From: MARTIN Michele * DEQ <Michele.MARTIN@deq.oregon.gov>
Sent: Thursday, January 25, 2024 12:09 PM
To: Clinton Cheney <ccheney@civilwest.net>; MICHIE Ryan * DEQ <Ryan.MICHIE@deq.oregon.gov>; TEMPERATURETMDL Willamette * DEQ <Willamette.TemperatureTMDL@DEQ.oregon.gov>; KUIKEN Brenda * DEQ <Brenda.Kuiken@deq.oregon.gov>
Cc: Max Baker <mbaker@ci.lowell.or.us>
Subject: RE: Lowell WWTP Thermal Load Calculation

Hi Clinton et al.,

Thank you for this information. Please submit this table, any other related data, and comments through the rulemaking channel – email to: Willamette.TemperatureTMDL@DEQ.oregon.gov.

Thank you,
Michele

Michele Martin MPA, Project Manager (she, her)
Oregon Department of Environmental Quality
Michele.Martin@deq.oregon.gov
P: 503-880-7737

From: Clinton Cheney <ccheney@civilwest.net>
Sent: Thursday, January 25, 2024 9:20 AM
To: MICHIE Ryan * DEQ <ryan.michie@deq.oregon.gov>; TEMPERATURETMDL Willamette * DEQ <Willamette.TemperatureTMDL@DEQ.oregon.gov>; KUIKEN Brenda * DEQ <Brenda.Kuiken@deq.oregon.gov>
Cc: Max Baker <mbaker@ci.lowell.or.us>; MARTIN Michele * DEQ <Michele.MARTIN@deq.oregon.gov>
Subject: RE: Lowell WWTP Thermal Load Calculation

Some people who received this message don't often get email from ccheney@civilwest.net. [Learn why this is important](#)

Thanks Ryan,

Yes, I see the issue. The City has a flow totalizer that records total gallons like an analog meter, and the 24-hour flowrate is calculated as the difference in flow volume between the next date and the reported date (and a conversion from gpd to mgd). For that date, the previous day's total volume wasn't subtracted out of the calculation. So, the 1.93 million gallons that was reported was just the totalizer reading from 9/23/2017, not the flowrate for that 24-hour period.

I've attached the wheel record from Lowell's effluent flowmeter from that date for reference. I think it's clear that record flow was a typo.

Regarding public comments – the DEQ email that comments are supposed to be addressed to is on this chain (willamette.temperaturetmdl@deq.oregon.gov). Is there another avenue I should go to get this error corrected? It would be terrible if a data entry error like this was reflected in an official DEQ rule.

Previous days read		Current day read or value		24hr flow	Check
Date	Rain	flow totalize			
9/4/2017	0.00	778331	0.059	0.059	
9/5/2017	0.00	837745	0.058	0.058	
9/6/2017	0.00	895419	0.066	0.066	
9/7/2017	0.20	961685	0.055	0.055	
9/8/2017	0.00	1016837	0.045	0.045	
9/9/2017	0.00	1061655	0.050	0.050	
9/10/2017	0.00	1111537	0.059	0.059	
9/11/2017	0.00	1171030	0.054	0.054	
9/12/2017	0.00	1224785	0.055	0.055	
9/13/2017	0.00	1279372	0.049	0.049	
9/14/2017	0.00	1328743	0.047	0.047	
9/15/2017	0.00	1376080	0.059	0.059	
9/16/2017	0.00	1434980	0.043	0.043	
9/17/2017	0.25	1477500	0.064	0.064	
9/18/2017	0.50	1541614	0.079	0.079	
9/19/2017	0.65	1620615	0.112	0.112	
9/20/2017	0.05	1732273	0.118	0.118	
9/21/2017	0.00	1850358	0.062	0.062	
9/22/2017	0.00	1912763	1.963	0.051	
9/23/2017	0.00	1963364	0.047	0.047	
9/24/2017	0.00	2010060	0.055	0.055	
9/25/2017	0.00	2065185	0.045	0.045	
9/26/2017	0.00	2110060	0.047	0.047	
9/27/2017	0.00	2157514	0.061	0.061	
9/28/2017	0.00	2218220	0.054	0.054	
9/29/2017	0.00	2272421	0.048	0.048	
9/30/2017	0.30	2320217	0.049	0.049	

Thanks,

Clinton Cheney, MS, PE
 Project Manager
 Professionally Licensed in Oregon (#093044)
 d 541.982.4118 | c 541.290.7068



Civil West Engineering Services, Inc.
 200 Ferry St. SW, Albany, OR 97321
www.civilwest.com

From: MICHIE Ryan * DEQ <ryan.michie@deq.oregon.gov>
Sent: Wednesday, January 24, 2024 4:13 PM
To: Clinton Cheney <ccheney@civilwest.net>; TEMPERATURETMDL Willamette * DEQ <Willamette.TemperatureTMDL@DEQ.oregon.gov>; KUIKEN Brenda * DEQ <Brenda.Kuiken@deq.oregon.gov>
Cc: Max Baker <mbaker@ci.lowell.or.us>; MARTIN Michele * DEQ <Michele.MARTIN@deq.oregon.gov>
Subject: RE: Lowell WWTP Thermal Load Calculation

Hi Clinton,

Attached is a copy of the DMR submitted to DEQ by Lowell STP from September 2017. 1.96 MGD was reported on September 22nd. Scanning the flows from other days it does look like the reported effluent flow that day might be an outlier. If you believe this was an error please let us know and consider submitting public comments on the TMDL. We can consider a correction. Our objective with the wasteload allocation is for it to be calculated using a maximum effluent flow (either maximum reported or design).

Thanks,
 Ryan

Ryan Michie | Senior Water Quality Analyst
 Oregon Department of Environmental Quality | Watershed Management Section
 700 NE Multnomah St., Suite #600, Portland, OR 97232
Ryan.Michie@deq.oregon.gov | (503) 229-6162

From: Clinton Cheney <ccheney@civilwest.net>
Sent: Wednesday, January 24, 2024 11:42 AM
To: TEMPERATURETMDL Willamette * DEQ <Willamette.TemperatureTMDL@DEQ.oregon.gov>; KUIKEN Brenda * DEQ <Brenda.Kuiken@deq.oregon.gov>; MICHIE Ryan * DEQ <ryan.michie@deq.oregon.gov>
Cc: Max Baker <mbaker@ci.lowell.or.us>
Subject: Lowell WWTP Thermal Load Calculation

Some people who received this message don't often get email from ccheney@civilwest.net. [Learn why this is important](#)

Hi,

In an earlier email (see below), I was told that the flowrate (1.96 MGD) used in the City of Lowell WWTP thermal waste load calculation was from their September 2017 DMR. 1.96 MGD is an extraordinary flow for a WWTP the size of Lowell's, even for a peak instantaneous flow. I believe there's a possibility that flow is an error.

Can you please send me a copy of the September 2017 DMR that DEQ received?

Thanks,

Clinton Cheney, MS, PE
Project Manager
Professionally Licensed in Oregon (#093044)
d 541.982.4118 | c 541.290.7068



Civil West Engineering Services, Inc.
200 Ferry St. SW, Albany, OR 97321
www.civilwest.com

From: ULIBARRI Julie * DEQ <Julie.ULIBARRI@deq.oregon.gov>
Sent: Tuesday, October 17, 2023 11:53 AM
To: Clinton Cheney <ccheney@civilwest.net>
Cc: KUIKEN Brenda * DEQ <Brenda.Kuiken@deq.oregon.gov>; WOOLVERTON Priscilla * DEQ <Priscilla.WOOLVERTON@deq.oregon.gov>; NOMURA RANEI * DEQ <RANEI.NOMURA@deq.oregon.gov>
Subject: RE: Mercury TMDL Question

I received some additional information from the TMDL group. Please see below.

Willamette Subbasins TMDL project website:
<https://www.oregon.gov/deq/wq/tmdls/Pages/tmdlRwillamette.aspx>

TMDL rulemaking website (rulemaking advisory committee documents, draft rules, and draft TMDL documents):
<https://www.oregon.gov/deq/rulemaking/Pages/willamettetempTMDL.aspx>

In terms of the draft WLA, the table below shows the allocation at 7Q10 flows. They have the option to implement this allocation as a flow-based allocation. The approach is described on page 32 of the [draft TMDL](#) and uses Equation 2. For 7Q10, we assumed the flow through the penstock defined flow available for mixing. In TMDLs we assume 100% mix. We used USGS 14150000 to define flow from penstock. Effluent discharge was characterized from 2015-2019 DMRs. The max discharge of 1.96 MGD was reported on September 2017 DMR. The WLA period is based on the time period when the Middle Fork Willamette River exceeds the applicable temperature criteria.

If there are any questions about the TMDL process or schedule, they can reach out to Michele Martin (michele.martin@deq.oregon.gov).

If they have questions about the TMDL technical work or the WLA they can reach out to me (ryan.michie@deq.oregon.gov).

NPDES Permittee WQ File# : EPA Number	Allocated Human Use Allowance (°C)	WLA period start	WLA period end	Annual 7Q10 River flow (cfs)	Effluent discharge (MGD)	Effluent discharge (cfs)	WLA (kcal/day)
Lowell STP 51447 : OR0020044	0.03	5/1	11/15	998.4	1.96	3.03	73,505,100

From: ULIBARRI Julie * DEQ <Julie.ULIBARRI@deq.oregon.gov>
Sent: Tuesday, October 17, 2023 8:16 AM
To: Clinton Cheney <ccheney@civilwest.net>
Cc: KUIKEN Brenda * DEQ <Brenda.Kuiken@deq.oregon.gov>; WOOLVERTON Priscilla * DEQ <Priscilla.WOOLVERTON@deq.oregon.gov>; NOMURA RANEI * DEQ <RANEI.NOMURA@deq.oregon.gov>
Subject: RE: Mercury TMDL Question

Good morning,

Please see responses to the questions below. We can set up a time to talk if you would like. Let me know.

1. Correct me if I'm wrong: the Middle Fork Willamette is listed as impaired for temperature both upstream and downstream of Dexter Reservoir, although the reservoir itself is not listed for temperature. How is that possible – stratification, different criteria for lakes and rivers, etc.?

DEQ response-The reservoir is part of an “assessment unit” (HUC12) that is categorized as impaired in the approved 2022 Integrated Report, which means the assessment unit has at least one impairment for temperature, i.e., even though Dexter reservoir itself may not be impaired for temperature it is part of an assessment unit that is. Please note that DEQ’s integrated report is updated every two years with any current monitoring data.

2. On their permit, Lowell is considered a river outfall (at RM 15.7 of Middle Fork Willamette), although they really discharge to Dexter Reservoir right at the penstocks. Are the Army Corps reservoirs part of the Willamette Subbasins temperature TMDL project area? Since Lowell is considered a river discharge in their permit, would they fall under the Willamette mainstem and major tributaries project area?

DEQ Response- Lowell WWTP is included in the DRAFT Subbasins Temp. TMDL. The outfall location is in the reservoir about 20ft. upstream of the penstock intake. Lowell WWTP has been given a proposed WLA in the Subbasins Temp. TMDL. We don’t know anything for sure until the TMDL is approved and issued. DEQ is working on an extension to issue in August or September 2024.

3. To my understanding Lowell doesn't have a temperature limit because of their unique mixing zone, i.e., the volume of water released from Dexter is much larger than Lowell's effluent flow and therefore the temperature of the water released from the dam is not affected in a meaningful way. I pasted their mixing zone definition below for reference. Should the City expect this mixing zone definition to change/be updated when their permit is renewed?

DEQ Response-The table below contains the proposed waste load allocation for Lowell. This is a flow-based waste load allocation. Therefore, Lowell will have the option to use an equation to calculate the limit when the flows are greater than the 7Q10 river flow. The equation will be listed in the NPDES permit

when it is renewed.

NPDES Permittee WQ File#: EPA Number	Allocated Human Use Allowance (°C)	WLA period start	WLA period end	Annual 7Q10 River flow (cfs)	Effluent discharge (MGD)	Effluent discharge (cfs)	WLA (kcal/day)
Lowell STP 51447 : OR0020044	0.03	5/1	11/15	998.4	1.96	3.03	73,505,100

The excess thermal load of the effluent will need to be calculated to determine if the discharge will be able to comply with the waste load allocation . See equation below:

$$ETL=QE \times (TE-TR) \times 3.785$$

Where,

ETL= Excess Thermal Load, million Kcal/day

QE= Daily average effluent flow, MGD

TE= Daily maximum effluent temperature, °C

TR= Applicable criterion, °C (will be listed in the TMDL and in permit renewal)

3.785= Conversion factor

During permit renewal development, the mixing zone will be re-evaluated using the receiving stream 7Q10 and effluent discharge flows (typically past 5 years). I am not sure if the mixing zone will stay at 5% and the zone of initial dilution at 1%. It is a good place to start since it is in the current permit and a small portion of the stream flow.

From: Clinton Cheney <ccheney@civilwest.net>

Sent: Tuesday, October 3, 2023 3:35 PM

To: NOMURA RANEI * DEQ <RANEI.NOMURA@deq.oregon.gov>

Cc: ULIBARRI Julie * DEQ <Julie.ULIBARRI@deq.oregon.gov>; KUIKEN Brenda * DEQ <Brenda.Kuiken@deq.oregon.gov>; WOOLVERTON Priscilla * DEQ <Priscilla.WOOLVERTON@deq.oregon.gov>

Subject: RE: Mercury TMDL Question

Thank you Ranei, much appreciated.

Regarding Lowell, I also have a few temperature questions, which I'm sure you all get a lot of these days:

1. Correct me if I'm wrong: the Middle Fork Willamette is listed as impaired for temperature both upstream and downstream of Dexter Reservoir, although the reservoir itself is not listed for temperature. How is that possible – stratification, different criteria for lakes and rivers, etc.?
2. On their permit, Lowell is considered a river outfall (at RM 15.7 of Middle Fork Willamette), although they really discharge to Dexter Reservoir right at the penstocks. Are the Army Corps reservoirs part of the Willamette Subbasins temperature TMDL project area? Since Lowell is considered a river discharge in their permit, would they fall under the Willamette mainstem and major tributaries project area?
3. To my understanding Lowell doesn't have a temperature limit because of their unique mixing zone, i.e., the volume of water released from Dexter is much larger than Lowell's effluent flow and therefore the temperature of the water released from the dam is not affected in a meaningful way. I pasted their mixing zone definition below for reference. Should the City expect this mixing zone definition to change/be updated when their permit is renewed?

From 2014 NPDES permit:

“The mixing zone is defined as five percent of the stream flow from Dexter Reservoir through Dexter Dam. The zone of initial dilution is defined as one percent of the stream flow from Dexter Reservoir through Dexter Dam.”

Thanks,

Clinton Cheney, MS, EIT

Staff Engineer

d 541.982.4118 | c 541.290.7068

Civil West

Engineering Services, Inc.

Civil West Engineering Services, Inc.

200 Ferry St. SW, Albany, OR 97321

www.civilwest.com

From: NOMURA RANEI * DEQ <RANEI.NOMURA@deq.oregon.gov>

Sent: Tuesday, October 3, 2023 10:44 AM

To: Clinton Cheney <ccheney@civilwest.net>

Cc: ULIBARRI Julie * DEQ <Julie.ULIBARRI@deq.oregon.gov>; KUIKEN Brenda * DEQ <Brenda.Kuiken@deq.oregon.gov>; WOOLVERTON Priscilla * DEQ <Priscilla.WOOLVERTON@deq.oregon.gov>

Subject: RE: Mercury TMDL Question

Clinton,

Priscilla referred your questions to me as I manage the permitting program for DEQ's Western Region. I've copied Brenda Kuiken and Julie Ulibarri on this email as well. Brenda is now DEQ's inspector for Lowell and Julie is your contact for facility plan questions who I believe you've already met.

You are correct in your reading of the Willamette TMDL that DEQ does not expect minor domestic wastewater treatment facilities in the Willamette Basin to need mercury controls or limits in their NPDES permits.

Also, a "major" domestic wastewater treatment facility is typically one that has a design flow of 1 MGD or greater or a service population of 10,000 or greater. For the 1 MGD flow threshold, DEQ has

interpreted this to be average dry weather design flow. DEQ may also change a minor designation to major if it determines there are other factors that affect the discharge, such as a large contribution of flow coming from a particular type of industry with known toxics in its wastewater. FYI, below is an excerpt from [EPA's NPDES Permit Writers' Manual](#) that discusses the designation process.

Please let me know if you have any additional questions.

Ranei

Ranei Nomura
Water Quality Program Manager
DEQ Western Region
503-378-5081
Pronouns: she, her, hers

2.4 Major/Minor Facility Designation

In addition to categorizing facilities as municipal and non-municipal, EPA has also developed criteria to determine which of the sources should be considered *major facilities*. The distinction was made initially to assist EPA and states in setting priorities for permit issuance and reissuance. The regulations at § 122.2 define major facility as, "any NPDES *facility or activity* classified as such by the Regional Administrator, or in the case of *approved state programs*, the Regional Administrator in conjunction with the [s]tate Director." All facilities that are not designated as *majors* are considered *minor facilities*.

Through policy, including the memoranda [Procedures for Revising the Major Permit List](#)¹¹ <www.epa.gov/npdes/pubs/owm0364.pdf> and [Delegation of Updates to Major/Minor Lists](#)¹² <www.epa.gov/npdes/pubs/owm0142.pdf>, EPA has established working definitions for POTW and non-municipal major facilities. For POTWs, major facilities are those that have a design flow of one million gallons per day or greater or serve a population of 10,000 or more or cause significant water quality impacts. Non-POTW discharges are classified as major facilities on the basis of the number of points accumulated using the [NPDES Permit Rating Work Sheet](#) <www.epa.gov/npdes/pubs/owm0116.pdf>. The worksheet evaluates the significance of a facility using several criteria, including toxic pollutant potential, flow volume, and water quality factors such as impairment of the receiving water or proximity of the discharge to coastal waters.

From: Clinton Cheney <ccheney@civilwest.net>
Sent: Thursday, September 28, 2023 3:41 PM
To: WOOLVERTON Priscilla * DEQ <priscilla.woolverton@deq.oregon.gov>
Subject: Mercury TMDL Question

Hi Priscilla,

Hope you are doing well. I'm working on updating the City of Lowell's wastewater facilities plan. I just wanted to confirm my interpretation of the Willamette Basin TMDL and WQMP (Section 13.3.2.1 specifically):

The total mercury load from all minor sewage treatment plant facilities (population < 10,000) was estimated to be essentially 0 percent of the total mercury load in the Willamette Basin. As a minor sewage treatment plant facility, the City of Lowell will not be expected to perform additional mercury control or monitoring at the wastewater treatment plant. Mercury monitoring and treatment requirements may be required if/when the City's population surpasses 10,000 people, flow exceeds 1 million gallons per day, or if a major potential industrial source begins discharging into the City's sewer system, at which point the City would be considered a major sewage treatment plant facility. Compliance with the Mercury TMDL is currently accomplished through a TMDL implementation plan managed by the City's stormwater drainage program.

Am I off base? Also, even though it doesn't really matter for Lowell, is the "1 million gallons per day" threshold for major treatment plants an average annual flow?

Thanks,

Clinton Cheney, MS, EIT
Staff Engineer
d 541.982.4118 | c 541.290.7068



Civil West Engineering Services, Inc.
200 Ferry St. SW, Albany, OR 97321
www.civilwest.com



Northwest Pulp & Paper ASSOCIATION

Sent via: Willamette.TemperatureTMDL@DEQ.oregon.gov

March 11, 2024

Oregon Dept. of Environmental Quality
Attn: Michele Martin
700 NE Multnomah St., Suite 600
Portland, OR 97232

RE: **Willamette Subbasin Temperature TMDL Replacement rulemaking**

Ms. Martin,

Thank you for the opportunity for the Northwest Pulp & Paper Association (NWPPA) to provide comments on Oregon Department of Environmental Quality's (DEQ) Willamette Subbasin Temperature TMDL Replacement rulemaking.

INTRODUCTION

NWPPA represents ten member companies and 14 mills in Oregon, Washington and Idaho, five of which are located in Oregon and are in more rural communities. Our members are state and federally recognized essential businesses who keep vital paper products available across the United States and abroad. Oregon mills provide 4,000 union-backed, family wage jobs in some of Oregon's more rural, economically distressed communities. Mills provide a 3:1 job multiplier and are often the single largest taxpayer in these communities, a large portion of which is distributed as funding for schools and emergency services. Our members hold various permits issued by DEQ including National Pollutant Discharge Elimination System (NPDES) and 1200-Z stormwater permits.

NWPPA has long-standing-stakeholder participation in numerous DEQ advisory committees including groups on establishing regulatory programs, administrative rules and program improvement efforts. Our staff and members have participated in the development of rules in previous DEQ Rulemaking Advisory Committees (RAC), most recently participating in the RAC for the Willamette Subbasin Temperature TMDL replacement.

GENERAL COMMENTS

Time of day impacts to max temperature & Human Use Allowance

It is unclear whether DEQ took time-of-day into account when assessing the maximum temperature and human use allowance criteria. This is a critical element in reporting and compliance that should also be explained and accounted for in the draft rules. Temperature assessed during early morning hours has the potential to be significantly different than temperature assessed during the early afternoon or early evening hours. It is unclear whether assessed data used in allocating human use allowances has been based on more or less sensitive times of day and could therefore not be adequately reflective of attributable compliance risks based on reporting data. We would ask DEQ to clarify whether data points from multiple times of day were used in calculating human use allowances for point and non-point sources.

Additionally, the equation used for heat load calculation (max daily temp x max daily flow) overestimates the actual heat load. While it might be a sensible formula to use for setting a heat load standard, it would make more sense to use the average temperature to determine the actual heat load.

Inclusion of the McKenzie River Assessment Unit

The late inclusion of temperature TMDL updates to the McKenzie River Assessment Unit is concerning from a procedural standpoint. While the initial rulemaking process for the Willamette Subbasins started with informational webinars in January 2023, it is unclear when the process and decision to include the McKenzie River was initiated. RAC members were notified of this scope change on November 30, 2023, nearly 11 months after the first public webinar. However, a RAC meeting was not held to review the scope change and associated updates to the TMDL. Some key stakeholders, such as NPDES permit holders, were not notified of the change until December of 2023.

While it is understandable that court mandated timelines on rulemakings are an added constraint, the stakeholder consultation process was significantly neglected. The McKenzie River was already slated to be included in the Willamette River mainstem and major tributary temperature TMDL that is set to begin in March 2024 and a short notice change in schedule warrants more explanation and communication on the part of DEQ. Additionally, informing stakeholders of this change just weeks before two major US holidays complicates things further given that it is very common for people to take time off during these holidays, rendering them less responsive or unavailable for stakeholder consultation.

Fiscal Impact

While the potential fiscal impacts associated with the initial Willamette Subbasin Temp. TMDL were reviewed with RAC members during the meetings held in February and April 2023, DEQ made what we believe to be an incorrect assumption that there would be no fiscal impacts associated with the inclusion of the McKenzie River assessment unit. This determination was made prior to stakeholder outreach or consultation and does not take into consideration potential fiscal impacts to our member, International Paper (IP), as well as to property owners that rely on IP's retention ponds along the Irving Slough as an identifiable property boundary. These property owners would likely incur costs associated with maintaining property boundaries during warmer months when the stormwater retention ponds have dried for the season.

CONCLUSION

Due to insufficient stakeholder consultation in the inclusion of the McKenzie River assessment unit, as well as the potential fiscal impacts to regulated entities and property owners, NWPPA and its members believe that DEQ should withdraw the McKenzie River assessment unit from consideration under the Willamette Subbasin Temperature TMDL and re-propose the TMDL under the Mainstem Willamette River Temperature TMDL, as was originally planned. This would provide an opportunity for more thorough stakeholder outreach, stakeholder representation during RAC meetings, and a reevaluation of the potential fiscal impacts of the TMDL.

NWPPA and its members are committed to evidence-based approaches to address and improve water body impairments. Again, NWPPA appreciates the opportunity to provide comments on ODEQs proposed Willamette Subbasin Temperature TMDL replacement. Please do not hesitate to reach out with questions about these comments.

Sincerely,

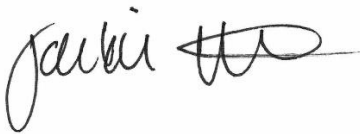

Jackie White
Director of Regulatory & Technical Affairs
Northwest Pulp & Paper Association



February 20, 2024

Oregon DEQ
Attn: Michele Martin
Water Quality
700 NE Multnomah Street Suite 600
Portland, Oregon 97232-4100

RE: Willamette Subbasin TMDL Rulemaking

The Oregon Department of Forestry (ODF) is providing the following comments in response to the Oregon Department of Environmental Quality's (DEQ) January 2024 draft Water Quality Management Plan (WQMP) for the Willamette Subbasin Temperature Total Maximum Daily Load (TMDL) and associated supporting documents.

The draft WQMP should allow for flexibility for implementation on forestland.

With the Board of Forestry adopting new and revised Forest Practices Act (FPA) rules in the fall of 2022 (effective January 2024), ODF staff are fully engaged in forestland owner outreach, internal and external training, and on the ground rule implementation assistance and enforcement. ODF encourages the ability to evaluate how these new rules are protective of water quality. Additionally, to ensure successful implementation of FPA rules and associated programs, ODF does not have additional capacity or resources to devote to the shade gap analysis and streamside evaluations prescribed in the draft Willamette Subbasin Temperature TMDL WQMP, and certainly not in the proposed required timeframe. Having a prioritized implementation strategy and appropriate timeline would allow ODF to fully engage in this work.

In section 2.1 *Streamside vegetation management strategies*, of the draft Willamette Subbasin Temperature TMDL WQMP, DEQ identifies the necessary strategies to meet the water quality standards in the temperature impaired waterbodies in the Willamette Subbasins. Table 1 below lists specific ODF Rule Divisions and rules that, when implemented, will ensure ODF is meeting the strategies to attain water quality standards.

Table 1. DEQ Streamside Vegetation Management Strategies and Correlating ODF's FPA Rules

DEQ Strategies	ODF Forest Practices Act Rules/ Best Management Practices
DEQ Strategy 1. Riparian Vegetation Planting and Establishment	ODF Rule Division 610 Reforestation Rules - (Associated Processes: Notifications, Guidance, Inspections, Enforcement, Compliance Monitoring, Enforcement, Adaptive Management)
DEQ Strategy 2. Riparian Vegetation Protection	ODF Rule Divisions for Water Protection: 635, 643, 645, 650, 655, 660 - (Associated Processes: Notifications, Guidance, Inspections, Enforcement, Compliance Monitoring, Adaptive Management)
DEQ Strategy 3. Riparian Vegetation Thinning and Management	ODF Rule 629-605-0173 – Planning for Forest Operations: Plan for Alternative Practices - (Associated Processes: Notifications, Inspections, Enforcement, Compliance Monitoring, Adaptive Management), OAR 629-643-0400, Plan for Alternative Practice (PFAP)

ODF implements rules and programs that employ best management practices, targeting DEQ's identified WQMP strategies including riparian vegetation planting and plant establishment, riparian vegetation protection, and riparian vegetation thinning and management. ODF is actively engaged in working with landowners to ensure proper riparian protection, management, and compliance. ODF desires to be successful as a Designated Management Agency (DMA) in helping Oregon private forestland owners meet the Willamette temperature TMDL non-point source load allocation targets. We will do this by working collaboratively with DEQ staff to adopt language in the WQMP that allows for flexibility in implementation approach and effectively uses the resources and authorities under ODF's existing framework. ODF also recommends that DEQ assist ODF in obtaining additional resources before "requiring" ODF to carry out such prescriptive and time intensive activities (i.e. shade gap analysis and streamside evaluations) for 10 expansive Willamette subbasins included in this TMDL.

Requested Corrections in the published draft TMDL documents

Correction 1: The statement "*These rules are not expected to result in after-the-fact restoration of riparian areas*" on page 20 of the draft WQMP is inaccurate for the following reasons: if a forest harvest operation occurred, forest practice rules require reforestation when stocking level fall below established thresholds. (OAR 629-610-0020 & -643-0500).

Landowners/operators conducting harvest operations under the FPA rules any time prior to January 1, 2024, are required to replant any harvested areas that fall below stocking standards due to tree harvest including areas within the wider no-touch Riparian Management Area's (RMAs) effective January 2024. After-the-fact restoration would have already occurred. Under the new buffer rules those areas planted that now fall within the wider required RMA buffers are not allowed to be harvested. **ODF requests DEQ remove this sentence from the draft WQMP.**

Correction 2: The following statement in draft WQMP is misleading: "*effective shade is likely to be deficient for those riparian areas adjacent to small and medium salmon, steelhead and bull trout streams that were harvested prior to implementation of the new rules.*" Page 20.

This statement suggests increased streamside vegetation regulatory improvements were not made until 2022. The Oregon Board of Forestry adopted new rules in July of 2017 for streams that are identified as having salmon, steelhead, and bull trout (SSBT) distribution. The SSBT rules resulted in wider RMA's and increased tree retention along such streams. ODF implemented wider stream buffer rules on small and medium salmon, steelhead, and bull trout streams seven years earlier than this sentence suggests. **ODF requests this sentence be revised or removed from the draft WQMP.**

Sincerely,



Cal Mukumoto
Oregon State Forester



Oregon

Tina Kotek, Governor

Department of Fish and Wildlife

Habitat Division
4034 Fairview Industrial Dr SE
Salem, OR 97302-1142
Voice: 503-947-6000
Fax: 503-947-6330
Internet: www.dfw.state.or.us

March 14, 2024

Department of Environmental Quality
Attention: Willamette Subbasins Temperature TMDL
700 NE Multnomah Street, Suite 600
Portland, OR 97232



RE: Comments on the Temperature TMDL Replacement: Willamette Subbasins Temperature TMDL

Dear Ms. Martin,

The Oregon Department of Fish and Wildlife (ODFW) appreciates the opportunity to provide comment on the Oregon Department of Environmental Quality's (ODEQ's) draft Willamette Subbasins Temperature TMDL. ODFW's mission is "to protect and enhance Oregon's fish and wildlife and their habitats for use and enjoyment by present and future generations." Water quality is an important component of habitat for fish and wildlife and ODFW supports efforts to maintain and enhance water quality conditions in Oregon's waterways. Through adoption of its climate and ocean change policy in 2020, the agency recognized that Oregon is already experiencing impacts from changing climate and ocean conditions, including high water temperatures which are a major threat to self-sustaining populations of vulnerable native species and severely limit population viability for Oregon's native anadromous species. These threats to aquatic habitat are likely to include longer summers and droughts, higher air and water temperatures, lower snowpack, decreased summer flows, and an increase in the magnitude and frequency of wildfires.

The Oregon Department of Fish and Wildlife (ODFW) offers the following comments and suggestions on the draft Willamette Subbasins Temperature TMDL.

Table 7-1 on pages 20 – 22 of the draft TMDL represents NPDES permitted point sources that have the potential to contribute a thermal load within the Willamette subbasins. Leaburg and McKenzie hatcheries should also be included in this table.

Table 7-1 on page 21 identifies Marion Forks hatchery discharge at River Mile 72.1. River Mile 72.1 is the confluence of Horn Creek and the North Santiam River. It is not an accurate location for the point of discharge on Horn Creek for Marion Forks hatchery.

ODFW suggest ODEQ consider the split in allocations between existing users and unknown future uses. In many cases, future development may be unlikely. For example, Table 9-6 on page 37 of the draft TMDL document provides a 0.10 Human Use Allowance (HUA) allocation for the Roaring River and Crabtree Creek in the South Santiam basin. Here the reserve capacity for the streams is larger than the amount allotted for current permitted facilities. Similarly, in Table 9-10, allocations

*To protect and enhance Oregon's fish and wildlife and their habitats
for use and enjoyment by present and future generations.*

for reserve capacity are double that of HUA allocations for Willamette and Marion Forks hatcheries, when these facilities are likely to be the only dischargers to their respective waterbodies.

Section 4.7.2, page 30, paragraph 2, sentence one should read “.....cool water species....”

The last paragraph on page 31, “larval” should be replaced with “larval lamprey”.

On page 34, paragraph 2 refers to footnote #2, however there is no footnote #2.

In Section 4.7.4, page 38, ODFW suggests using common names for winter steelhead and cutthroat trout for consistency/public understanding.

Technical Support Document

Figure 5-24 reflects the seasonal variation and critical period for the South Santiam below Green Peter Reservoir. ODFW encourages ODEQ to include a broader discussion on the box plot and the explanations why the temperature data is unique. USGS Gage 14186200 is directly below Green Peter Dam in the approximately three-mile stream reach between Green Peter Reservoir and Foster Reservoir, which serves as the re-regulating reservoir. Data are from non-surface withdrawal from Green Peter Reservoir before it flows into Foster Reservoir. ODEQ should consider either including more detailed information on the graph or excluding the graph since it is a heavily modified system that is not reflective of a free-flowing stream system.

Section 9.1.7 Determination of when minimum duties provision applies omitted Leaburg and McKenzie hatcheries. The minimum duties provision at OAR 340-041-0028(12)(a) states that anthropogenic sources are only responsible for controlling the thermal effects of their own discharge or activity in accordance with their overall heat contribution. ODFW requests this guidance be included for these facilities.

Appendix J and K

Appendix J provides a summary of the McKenzie River CE-QUAL-W2 Model Scenario Report for Point Source simulation. The report states “Two actual withdrawals were configured at the immediate upstream segments above the discharge locations. Regardless of whether the withdrawals are artificial or actual, only the flow rates are specified for withdrawals within W2. The model removes heat associated with the flow, based on the simulated water temperature at the withdrawal location.” ODFW is concerned that the model underestimates the thermal impact of withdrawal into the Leaburg Canal by essentially removing heat associated with the flows into Leaburg (up to 1400 cfs) and assigning the resulting thermal load downstream of Leaburg Dam to ODFW hatcheries. ODFW requests further explanation of how the model differentiates the impact of diversion to the Leaburg Canal from the impact of hatchery discharge. Similarly, clarification of how and where the model incorporates return flow from the canal diversion is recommended. The model that was used was based on the year 2015, which was an historic low flow year and included withdrawals into the Leaburg Canal. The Leaburg Canal has been decommissioned and no longer maintains water in the canal. How will this be reflected in the wasteload allocations for Leaburg and McKenzie hatcheries? In addition, please provide information on how ODEQ validated this model with measured temperature data.

Second, how does the model incorporate the diel nature of hatchery effluent flows, which mimic the diel temperature flux of the mainstem McKenzie River? In contrast to a wastewater treatment plant whose effluent temperatures remain relatively constant during a 24-hour period, temperatures of effluent flows at the hatcheries fluctuate over a 24-hour period, mirroring the diel fluctuation of temperatures in the mainstem (the source water for the hatcheries). Continuous temperature data are taken at hatchery discharge locations at 15-minute intervals, and the daily maximum temperature is used to calculate the thermal load of the hatcheries.

ODEQ uses a very conservative assumption that the maximum temperature is assumed to be static over a 24-hour period, when it may only reach that temperature for a brief 15-minute period or over several hours. This conservative assumption overestimates the thermal load from the hatchery discharge, which is illustrated in Figures 1-1 through 1-3. This results in a modeled maximum temperature increase of 0.03 degrees Celsius which is not measurable by current technology and has an error rate of approximately 0.2 °C.

ODFW requests DEQ clarify differences in effluent flows reflected in Tables 2 through 10. Effluent discharge was modeled using data from 2016. Discharge for the months of June 15 – August was abnormally low compared to operations in most years, which is reflected in a wasteload allocation (WLA) that is not representative of normal hatchery operations. ODFW requests that DEQ incorporate additional years of data into WLA model scenarios. The 7Q10 river flow rates used to derive WLAs for Leaburg Hatchery and McKenzie River Hatchery do not reflect changes in flows that will occur when the Leaburg Hydroelectric Project is decommissioned. ODFW requests DEQ include text that WLAs will be recalculated following completion of decommissioning of the Leaburg Hydroelectric Project.

It is also notable that hatchery source water temperatures and dilution flows vary interannually with prevailing climatic conditions. ODFW encourages DEQ to provide more clarification of how effluent temperatures were calculated and used in the model and requests DEQ incorporate additional years (> one year) of temperature monitoring at McKenzie and Leaburg hatcheries to further refine proposed wasteload allocations.

ODFW supports a continued collaborative approach to protecting Oregon's aquatic resources and looks forward to working with DEQ to continue to protect Oregon's valuable natural resources using state resources as efficiently and effectively as possible.

Sincerely,



Rebecca Anthony
Water Quality Specialist
Oregon Department of Fish and Wildlife

cc: Chandra Ferrari, ODFW
Shaun Clements, ODFW

Willamette.TemperatureTMDL@DEQ.oregon.gov

March 14, 2024

Oregon DEQ
Attn: Michele Martin, Water Quality
700 NE Multnomah Street, Suite 600
Portland, Oregon 97232-4100

RE: Willamette Subbasins TMDL Proposed Rules Public Comment

With regard to the Draft Water Quality Management Plan (WQMP) – Willamette Subbasins TMDL Temperature, ODOT submits the following comments:

Section 2.4: DEQ expects that entities identified in Section 5.1 will incorporate strategies and practices listed in Table 2 that are applicable to their jurisdiction in their implementation plans. Implementation plans must include specifics on where and when priority and other strategies and practices will be applied.

Comment 1: ODOT activities that limit stream shade are outside of our control to change without jeopardizing public safety. To the extent that it is able, ODOT manages this land in numerous ways that have a beneficial effect on stream temperatures.

- a. Adding vegetation is mostly incompatible with ODOT's primary function of building and maintaining roads that are safe. ODOT rights of way consist of three sections:
 - i. The paved roadway. This portion of the right of way is not available for planting.
 - ii. The clear zone. This section of right of way is kept clear of non-traversable hazards and fixed objects (including trees) to help ensure that roadway departures result in recovery rather than crash, and to minimize the severity of roadway departure crashes that do occur. Clear zone vegetation is also maintained for other purposes such as maintaining motorist sight distances. The AASHTO Roadside Design Guide recommends a clear zone width of up to 46 feet from the edge of pavement, depending on posted speed limits, traffic volume, and roadside slope and curvature. The clear zone is not available for planting, and in many locations extends fully to the right of way boundary.
 - iii. In some sections of highway, some space remains between the outer clear zone boundary and the property line. It is only in these locations that there is any possibility of taking action that could shade streams.
- b. Plantable areas that are on the opposite side of the highway from the stream are of minimal value because trees planted there would have to grow a prolonged period of time before providing any shade to the stream.

- c. The portion of ODOT right of way that is paved is subject to increase over time as capacity needs increase. This may result in shifting the clear zone toward the property boundary and widening it, and therefore may restrict the width of any remaining right of way outside the clear zone. This is consistent with the intended purpose of the right of way.
- d. ODOT has no choice but to continue certain tree removal activities (including outside the clear zone) for purposes such as maintaining clear zones, discouraging ice in hazard spots, removing trees in danger of falling onto the roadway, and preventing damage to structures such as culverts, bridges, and stormwater treatment facilities.
- e. ODOT already routinely engages in many activities that have a beneficial effect on stream temperature:
 - i. ODOT properly restores riparian areas when they are disturbed by ODOT projects.
 - ii. Streambank stabilization maintenance activities incorporate large wood and robust riparian plantings wherever practicable.
 - iii. Although it is sometimes necessary to remove trees as described above, it does so conscientiously and minimally.
 - iv. ODOT minimizes stream turbidity relating to construction activities through conscientious execution of erosion and sediment control plans and through the deployment of effective work area isolation BMPs during in-water work.
 - v. ODOT minimizes stream turbidity relating to stormwater discharges by including energy dissipation structures at outfalls and through flow control measures that prevent streambank erosion.

Section 5.1: Responsible persons including DMAs are organized by DMA type in the following subsections. These persons are responsible for developing or revising implementation plans and implementing management strategies to achieve the TMDL allocations. A complete list of responsible persons including DMAs for the Willamette Subbasins Temperature TMDL is in Appendix A. There are 137 responsible persons including cities, counties, federal and state agencies, and other entities.

Comment 2: The WQMP does not state what criteria were used to identify persons responsible for preparing and executing TMDL implementation plans. Appendix A indicates that ODOT is responsible for 4,856 acres within 150ft of a stream. It appears the decision that ODOT must prepare and execute a TMDL implementation plan is based on ODOT's ownership of land near streams, even in basins where the percentage of ODOT-owned land within the basin and the percentage of ODOT-owned land that is within 150 feet of a stream are both so small that when expressed in whole numbers, they round down to 0%. Based on land ownership areas alone there is little confidence that ODOT has the capability to meaningfully cause or alleviate temperature pollution.

OAR 340-042-0040 requires a reasonable assurance that management strategies and implementation plans will be carried out through regulatory or voluntary actions and that

practices capable of reducing the specified pollutant load exist, are technically feasible at a level required to meet allocations and have a high likelihood of implementation. In the case of ODOT, there is reasonable assurance that ODOT will continue having a beneficial effect on stream temperatures in the subject basins by executing myriad activities already required by various regulations and permits as described above. However, because ODOT is already engaging in these practices to the maximum extent practicable, there is no reasonable assurance that ODOT's preparation and execution of a TMDL implementation plan will meaningfully contribute to reducing loads. It would have no benefit to water quality and therefore be a poor use of public resources for these reasons:

- a. The amount of land ODOT owns is very small relative to the subbasin. (0% to 2%, averaging 0.5% according to Willamette Subbasins draft WQMP, Appendix B)
- b. The amount of land ODOT owns is very small relative to other responsible persons. (Less than 0.5% of the total of all responsible persons based on Appendix A; the true number is less because Appendix A doesn't enumerate the areas of special districts.) In other words, based on land area alone (and excluding special districts), ODOT owns less than 1/200th of the land owned or controlled by responsible persons generally.
- c. The percentage of ODOT land that is close to streams is very small. (0% to 1%, averaging 0.375% according to Willamette Subbasins draft WQMP, Appendix B)
- d. The great majority of lands that ODOT owns near streams are not at stream crossings, but rather in corridors where the highway parallels the stream such that ODOT has control over land on only one side of the stream. Unlike most responsible persons, ODOT controls at most only half of the riparian area which is probably not typically enough to fully close shade gaps. Therefore, each acre of ODOT land that is available for mitigative purposes is significantly less valuable qualitatively than each acre of land owned by most other responsible persons who can plant both sides of the stream.

Section 5.3.2: Responsible persons including DMAs that are required to submit an implementation plan must complete a streamside evaluation.

Comment 3: Requiring ODOT to complete a streamside evaluation will have no benefit to water quality and would be poor use of public resources for the reasons described in Comment 1 and Comment 2.

March 1, 2024

Oregon DEQ
Attn: Michele Martin
700 NE Multnomah St., Suite 600
Portland, OR 97232-4100

Via Email: Willamette.TemperatureTMDL@deq.oregon.gov

RE: Oregon DEQ Proposed Willamette Subbasins Temperature TMDL

Dear Ms. Martin:

Thank you for the opportunity to provide comment on the Department of Environmental Quality's (DEQ) proposed Willamette Subbasins Temperature TMDL rulemaking (the "rulemaking"). These comments are being submitted on behalf of Oregon Forest & Industries Council (OFIC), which represents forestland owners and forest products manufacturers from across the state of Oregon. Together, our members provide for themselves, their families and nearly 60,000 other households via direct employment from our lands and manufacturing facilities.

OFIC has been engaged in the current rulemaking as a member of the Rulemaking Advisory Committee (RAC) where we were represented by Rich Wildman from Geosyntec. We have also had opportunities to address questions and concerns directly to the DEQ rulemaking team outside of RAC meetings, and we appreciate the open-door policy that you have maintained throughout this process. We understand that DEQ has been working on something of an expedited schedule in an effort to meet court-mandated deadlines for completion of this revised TMDL, yet notwithstanding these real time constraints, your team has been communicative and has clearly made an effort to address concerns whenever possible. For that we thank you.

It is also with respect for the tight schedule that DEQ is working on that we wish to be as direct as possible with these comments. We recognize the importance at this stage of development for offering proposed solutions to identified problems rather than just pointing out the problems themselves. To that end, we would like to raise a number of issues of concern that we have with the draft TMDL and propose tangible ways that these concerns could be addressed by the agency in the final rule. After DEQ has had an opportunity to review and digest these suggestions, we are happy to answer any clarifying questions that your team might have.

1.) The Numeric Shade Targets Should Be Removed from the Final Rule

For the first time that we are aware of, DEQ has set numerical shade targets for each jurisdiction (by Designated Management Agency) across the subject area. These targets are based on DEQ modeling that attempts to recreate what “restored” vegetative conditions would look like and therefore what degree of shading the basin-wide river and stream network would receive absent human impacts. Table 9-14 in the proposed rule reflects these effective shade surrogate measure targets and – of immediate relevance for OFIC’s private forest landowner members – assigns a numeric shade target of 96% effective shade for all private forests regulated by the Oregon Department of Forestry (ODF) in the Southern Willamette Basin.

We are concerned about the inclusion of these numeric targets for three primary reasons.

a. Numeric Shade Targets Effectively Treat Nonpoint Sources as Point Sources

The Clean Water Act (CWA) maintains a clear distinction between the regulation of point sources and nonpoint sources for purposes of allocating loading for waters that are impaired as to a given water quality criteria. Point sources that are required to operate under NPDES permits (whether individual or general) are subject to mandatory, enforceable effluent limitations that are meant to ensure that these sources do not exceed the wasteload allocations assigned to them by the DEQ. For point sources, the analysis is simple: discharges must meet numeric effluent limits in order to be in compliance with the Act. For nonpoint sources, on the other hand, a considerable amount of flexibility is provided by the Act for demonstrating compliance and achieving the load allocations written into a TMDL. However, by assigning an effective shade target to each DMA authorized by DEQ to implement the TMDL, DEQ is essentially treating each nonpoint source category as a single point source, merely swapping in a numeric shade measurement for the numeric effluent limits that would be imposed on a permitted point source.

There is a clear reason that the CWA distinguishes between point and nonpoint sources: the principles that apply to one simply do not fit the other. This is especially true when dealing with a water quality standard such as temperature. There are myriad factors that impact the temperature of water on the landscape (a fact reflected by the complexity built into the Heat Source model used by DEQ), and that complexity means that a single surrogate measure, such as shade, effects different waterbodies in different ways depending on a host of attendant factors. The draft rule ignores this, and essentially treats shade the same way as it treats effluent from a single, discreet conveyance.

b. Numeric Shade Targets Treat Temperature Impacts from Solar Radiation Flux as Uniform and Non-Attenuating

This raises a second issue with DEQ’s numeric shade targets. Even assuming that the amount of effective shade is in all instances directly correlated to the temperature of a waterbody (which may not be the case), DEQ ignores evidence suggesting that the *magnitude* of the impact of solar radiation flux is different for different waterbodies (e.g. Vannote et al. (1980); Poole and Burman (2001)) and that such impacts have been shown not to be persistent, but to attenuate over space and time (Bladon et al. (2018)). That is to say, there is abundant evidence suggesting that

uncovering a portion of a stream does not result in a persistent increase in stream temperature, but that downstream shading will attenuate upstream impacts. This casts doubt on DEQ's reliance on basin-wide shade targets as necessary and sufficient for meeting nonpoint source load allocations and calls for a more circumspect approach when it comes to addressing landscape-level loading from nonpoint sources.

c. Unresolved Questions Regarding the Accuracy of DEQ's Shade Targets Calls for Removal

Finally, as OFIC and Geosyntec have noted in the past, we have numerous concerns with the assumptions that are built into DEQ's shade model, which concerns, if validated, cast doubt on both the accuracy and achievability of DEQ's shade targets. We have raised concerns regarding the amount of natural disturbance built into DEQ's model and the distribution of that disturbance across the landscape (more on this, below). We have also raised concerns regarding the accuracy of modeled effective shade when compared with in situ measurements from published studies (e.g. Kaylor et al. (2017); Warren et al. (2013); Fiala et al (2006)). Of the major watershed studies in Oregon that we are aware of, none have demonstrated 96% effective average shade. In fact, only two of seventy-seven study sites in the Alsea, Trask, Hinkle, RipStream, ODF 2001, and Andrews studies reached 96% shade, even in dense, mature second-growth forests that, as Kaylor et al. demonstrated in their 2017 study, are consistently *more* shaded than old-growth stands (Allen and Dent, 2001; Bladon et al., 2016; Groom et al., 2011; Kibler, 2007; Reiter et al., 2020; Warren et al., 2013).

This casts serious doubt on DEQ's assessment of system potential vegetation and effective shade in a "restored" forest condition. DEQ agreed in a conversation on 5 February 2024 that its approach is conservative. We would state it more strongly: the shade targets, based on DEQ modeling of restored conditions, are unrealistic and are likely impossible to achieve. We ask DEQ to remove prescriptive shade targets from the documents and give DMAs the flexibility to develop implementation plans with targets and strategies that are realistic to industry practices, to real-world restored conditions, and to the particularities of the streams within each DMA's jurisdictional boundaries.

We further ask DEQ to update its restored vegetation estimates. We understand that these were minimally updated for this revision of this TMDL. We did not find adequate explanation for values embedded in these estimates, including the fraction of land that was modeled as disturbed. It is inappropriate to continue to use this value from an outdated analysis without further justification.

2.) If DEQ Maintains Numeric Shade Targets in the Final Rule, the Target for Private Forestlands Should Be Significantly Decreased

As already stated, we have serious concerns regarding the accuracy and feasibility of the shade target established by DEQ for ODF-managed private forestland.

a. Existing Scientific Literature Supports a Lower Effective Shade Target

A review of six published shade studies has provided us with shade data from dense, second-growth forests in Western Oregon, which provide ideal shading conditions (Allen and Dent, 2001; Bladon et al., 2016; Groom et al., 2011; Kibler, 2007; Reiter et al., 2020; Warren et al., 2013). One study took place in the H.J. Andrews Experimental Forest and was split into two datasets to represent old-growth and second-growth forests separately (Warren et al., 2013). A second study, typically referred to as the “RipStream” study, was split into two datasets to represent small and medium sized streams separately (Groom et al., 2011). Out of the 77 pre-harvest study sites examined within these eight datasets, only 2 individual sites reach a value of 96% effective shade (Figure 1). No watershed study reached an average of 96% shade, and median shade values ranged from below 85% to between 90% and 95%. There is also significant variability within datasets, even among pre-harvest streams. We expect these pre-harvest streams to be representative of the restored shade conditions that DEQ has attempted to model. It is therefore unrealistic to expect restored shade conditions to exceed the shade conditions established by these studies, and we believe the "ODF - Private" effective shade target of 96% for the Southern Willamette Basin to be practically unattainable.

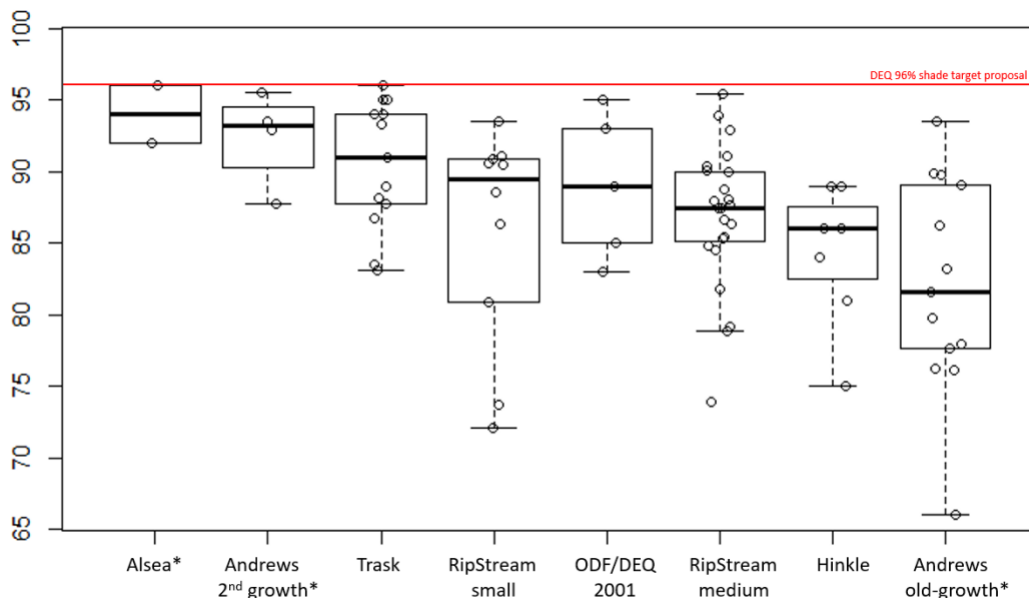

Figure 1. Distribution of effective shade values in pre-harvest streams in six major watershed studies in Western Oregon. Studies with an asterisk represent canopy closure values as opposed to hemispherical shade.

We understand from our conversation with DEQ on 5 February 2024 that the high effective shade values in the restored vegetation model, and the difference between model output and shade data from dense, second-growth forests, cannot be explained. This suggests that the model is not well calibrated at high shade values. It is therefore inappropriate for this model output to be used as a regulatory target.

Due to our concerns regarding the accuracy of DEQ’s shade model, especially as it pertains to measured and modeled shade values greater than 96%, we conducted an evaluation of the shade measurements used to calibrate the Southern Willamette Shade Model.

Figure 2 shows the measured values used to calibrate the model, as reported in Table 2-38 of the Heat Source Model Report (DEQ, 2024), along with the applicable HUC12 boundaries. The figure demonstrates that the 9 shade measurements of 96% or greater are located in three geographical areas:

- Five of the 9 measurements, including all four of the measurements greater than 96%, are located in close geographic proximity in Southern Lane County, in the Middle Fork Willamette area, specifically the Packard Creek-Middle Fork Willamette River, Buck Creek-Middle Fork Willamette River, and Coal Creek HUC12 subbasins.
- Three of the 9 measurements are located in the Shotcash Creek-Mohawk River HUC12 subbasin.
- One measurement is located in the Lower Mary’s River HUC12 subbasin.

The clustering of these shade measurements of 96% or greater, while numerous other measurements in areas of dense shade show substantially lower values, suggests potential inconsistency in the measurements. For example, use of different instruments or personnel, or inconsistent calibration, in some areas may result in elevated measurements inconsistent with other measurements. To the extent that these measurements are biased high, and given that even in dense, mature, second-growth forests, 96% shade is very rarely reached, this would have biased the calibration process—an inappropriately high Canopy Cover value would have been selected in the model to best match the biased measurements. This would have led to modeled values biased high in all modeled areas.

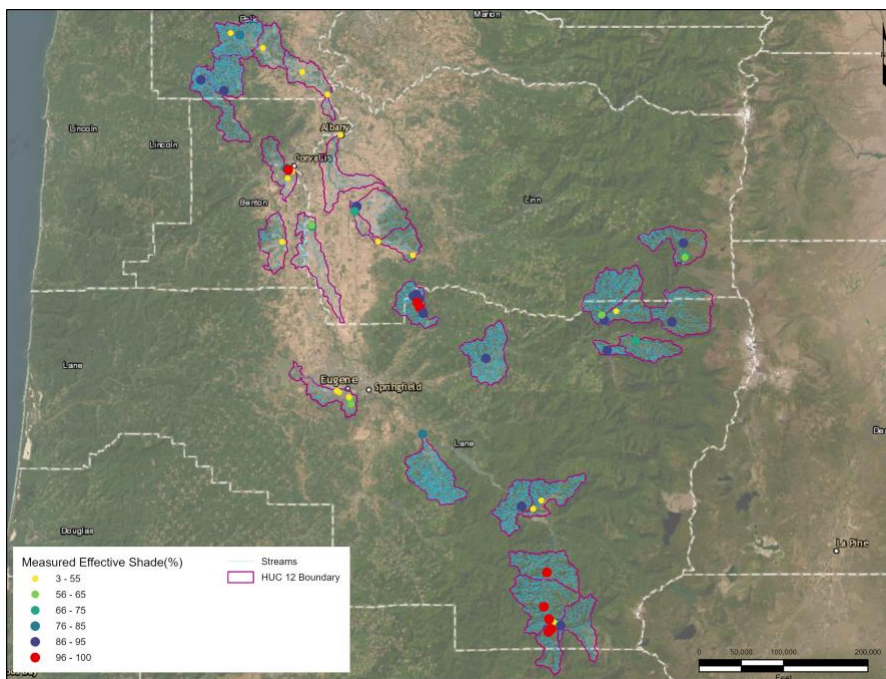

Figure 2. Measured shade values as reported in DEQ (2024), Table 2-38.

We also note, based on DEQ’s calibration scatterplot (Figure 3-248, reproduced below as Figure 3), that the model overpredicts measured values—even the measured values that appear unrealistically high—for high effective shade. The figure appears to show that for 27 of the 30 measurement points where measured shade exceeded 75% (based on Table 2-38), the modeled shade was equal or greater than the measured value, while only 3 of the measured points fall notably below the line. This again indicates that the model was calibrated to predict very high shade for forested areas, and the results are biased high as a result.

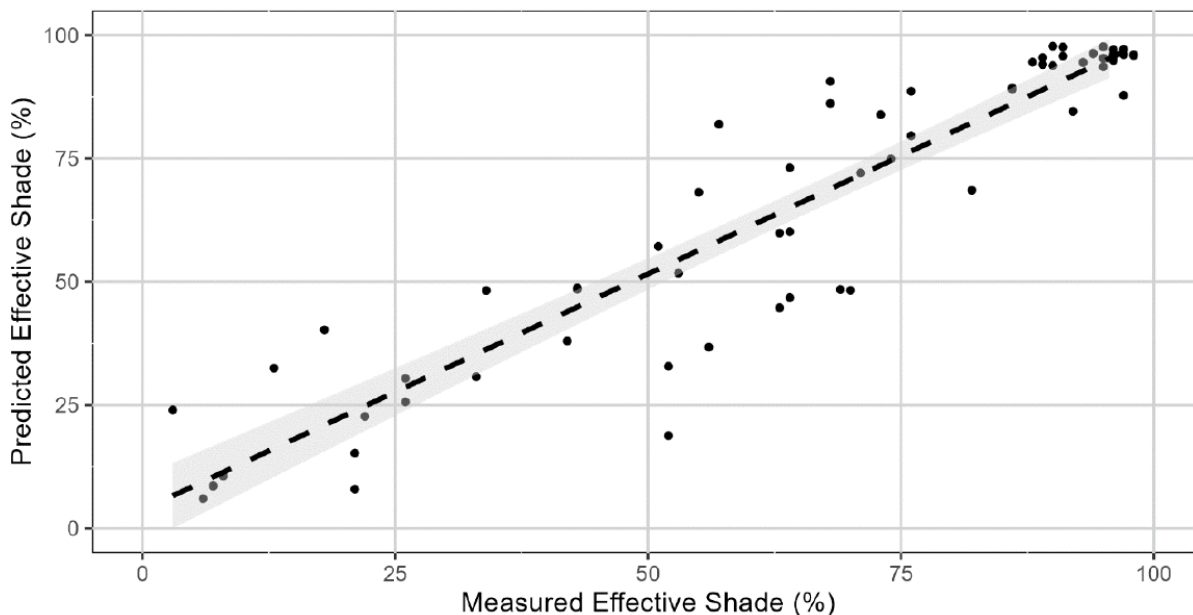

Figure 3-248: Southern Willamette measured and predicted effective shade. The dashed line is the best fit line and the grey area represents the confidence interval.

Figure 3. DEQ scatterplot assessing calibration of the Southern Willamette shade model. Reproduced from DEQ, 2024.

We ask DEQ to reassess its model calibration to reconcile the “ODF – Private” shade target with existing effective shade data and to consider setting a more realistic shade target that aligns with effective shade values in existing mature forests (Groom et al., 2011). A simple, albeit coarse, way to do this would be to cap maximum simulated shade values between 90% and 96% effective shade for post-processing and averaging by DMA. This would be done based on understanding that greater than 96% shading is not achieved, even under ideal conditions.

b. Modeling Parameters Regarding Disturbance Should Be Changed

Further, we believe that certain modeling parameters should be changed to better reflect real-world conditions. One obvious target is the manner in which DEQ has modeled for disturbance. At present, DEQ assumes 25% disturbance and evenly distributes this disturbance across the entire watershed. There are two issues with this approach.

First, it is not clear from where DEQ's 25% disturbance number is derived. Teensma et al. (1991) reported "at least 35%" and "probably more" of the area of the Pacific Coast Range mapped by the authors had been recently burned. While this study was for the Pacific Coast Range, and not the areas of the Willamette Subbasin TMDL encompassing the west Cascades, it appears to be the document cited in the "Appendix C" of the Technical Support Document *and* it is further supported by a 1902 USGS survey that similarly found over 33% of the forested land in Oregon west of the Cascade crest existed at that time in a recently burned-over state. It is unclear how DEQ obtained an estimate of 25% disturbance based on the Teensma study, and we specifically request that DEQ increase the assumed disturbance fraction to 35% and rerun its analysis or reduce the shade targets to account for this uncertainty.

Second, DEQ's chosen distribution of the disturbed fraction does not match natural patterns of disturbance. Perhaps the single most common cause of disturbance in Oregon's forest ecosystem is wildfire. Wildfire (and other natural sources of disturbance such as insect kill) cause large, contiguous patterns of disturbance while leaving areas outside of the boundaries of the fire relatively unaffected.

This runs counter to the way DEQ has modeled disturbance. DEQ has chosen to model disturbance (which, again, we believe should be set at 35% rather than 25%) dispersed evenly throughout the forestland portion of the restored conditions model, notwithstanding the fact that natural disturbances would create contiguous areas of disturbance. We recommend, therefore, that DEQ model contiguous disturbance by identifying a contiguous 35% of the stream nodes within the upland forest area and assigning all of the vegetation providing shade for these nodes the "Disturbed" model condition. Once this is done, we would ask DEQ to recalculate average shade under restored condition and make the corresponding changes to the identified shade targets and shade gaps.

To evaluate the effects of our suggested approach for modeling disturbance, we evaluated a contiguous 25% disturbance, following the approach described above. A contiguous 25% disturbance was used, rather than our recommended value of 35%, for comparison to the results in the draft TMDL. Specifically, we evaluated this approach for an example HUC12 subbasin, Middle Mosby Creek. This subbasin was selected as an example of a subbasin covered by forestland under the restored conditions scenario.

Figure 4 indicates the modeled scenario—the nodes highlighted yellow were selected as "disturbed" and all vegetation providing shade for these nodes used the "Disturbed" forestland condition (56-foot tree height, 25% density, and 2.0-meter overhang as outlined in Appendix C of the Technical Support Document). The remaining vegetation was assigned the "No Disturbance" forestland condition (160-foot tree height, 75% density, 4.9-meter overhang).

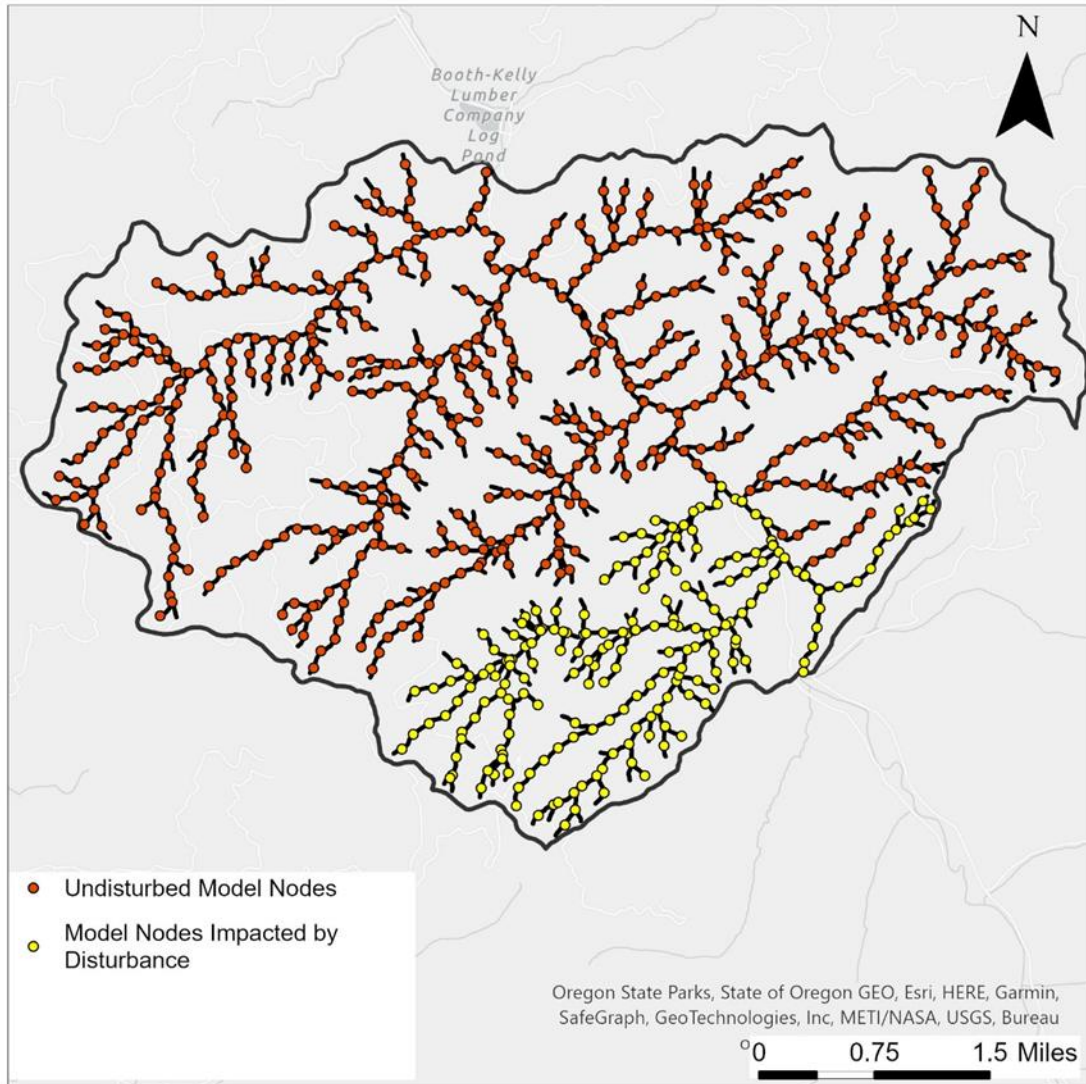

Figure 4. Middle Mosby Creek Subbasin nodes modeled as disturbed versus undisturbed.

We ran the shade model provided by DEQ for the condition described above and compared the results to the output for Middle Mosby Creek for DEQ’s restored conditions scenario. Figure 5 presents a comparison of the modeled shade. Specifically, each green dot in Figure 5 represents a modeled node from DEQ’s restored conditions scenario. There is a corresponding blue dot for each modeled node using the Contiguous 25% disturbance scenario. The figure indicates that, for many nodes, there is slightly more shade under the Contiguous 25% disturbance scenario—this is because the vegetation surrounding these nodes is fully undisturbed under the Contiguous 25% disturbance scenario, whereas there is random disturbance included in the DEQ restored conditions scenario. However, Figure 5 also shows that for nodes modeled as “disturbed,” much less shade is provided under the Contiguous 25% disturbance scenario compared with the restored conditions scenario. Importantly, these nodes do not receive 0% shade—the disturbed forestland condition described in Appendix C of the still includes 56-foot tall trees with 25% density. Nevertheless, when averaged over the modeled nodes for Middle Mosby Creek, the

restored condition average from the draft TMDL method for this subbasin is **97%**, while the average using the Contiguous 25% disturbance approach is **88%**. This analysis indicates that using a more realistic approach to modeling disturbance would result in a lower, and more justifiable, shade target.

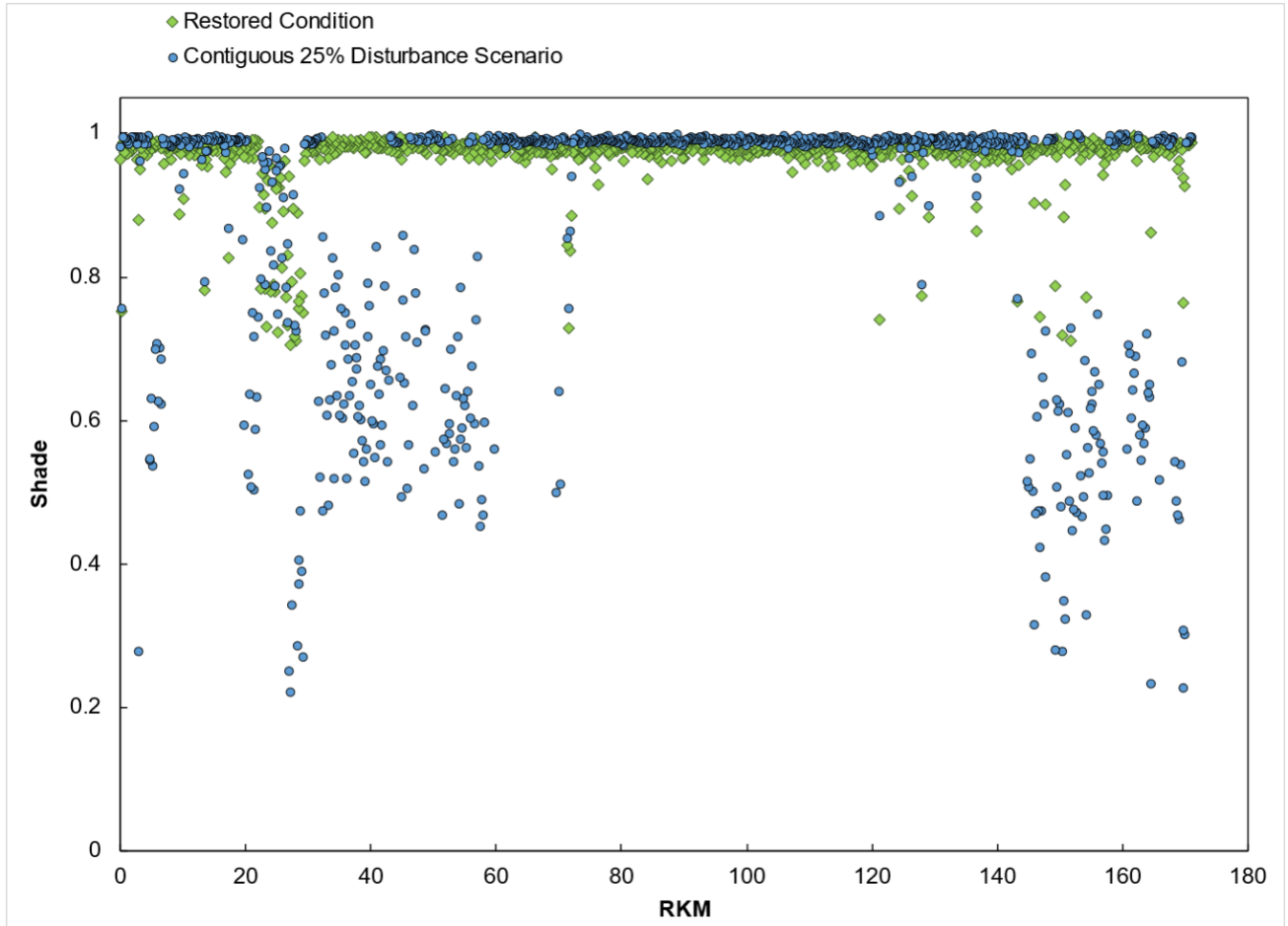

Figure 5. Comparison of DEQ Restored Conditions scenario to Contiguous 25% Disturbance "By Node" Scenario for Middle Mosby Creek.

We note again here that this example used a Contiguous 25% Disturbance, for purposes of comparison to DEQ's restored conditions scenario. However, based on our review of the literature, we request that DEQ use 35% disturbance.

c. ODEQ Should Address Divergence in Target Effective Shade Among TMDLs

As a final point of comment regarding the modeled effective shade under "restored" conditions, we observed that the target shade values in the Lower Columbia – Sandy TMDL are much lower than those in the Willamette Subbasins TMDL – more than what one would expect from natural regional variability (especially considering that the two regions even border one another). Given

that these two TMDLs are being replaced concurrently, DEQ should justify these differences and explain the methodological decisions that drive them.

3.) DEQ Should Provide More Flexibility for DMAs to Demonstrate Progress Toward Attainment of Water Quality Standards in Implementation Plans

Once the TMDL is finalized and has been approved by the Environmental Quality Commission, DEQ will require DMAs to craft and submit implementation plans for how DMAs will prioritize projects and demonstrate progress toward attainment of water quality standards. OFIC is concerned, insofar as ODF is the DMA with authority to implement the TMDL on private forestland, that DEQ is unnecessarily boxing in the agency, and not leaving flexibility for ODF to deploy the new Forest Practice Act (FPA) rules and the Adaptive Management process that was established as part of the updates that were made to the FPA in 2022.

As DEQ is no doubt aware, the FPA was recently amended to, among other things, materially increase riparian management restrictions (including expanded no-harvest buffers and equipment limitation zones) in an effort to better protect aquatic species habitat on private forestland. ODF is presently in the process of implementing the new forest practice standards established pursuant to the FPA.

The new FPA rules also include a process by which any future changes to the forest practice rules would be effected through rule review by an Adaptive Management Policy Committee (AMPC), which works in conjunction with an Independent Research and Science Team (IRST) to establish studies and review scientific literature in order to assess the effectiveness of the rules in meeting environmental goals and objectives. DEQ is represented on the AMPC.

We believe that the revised forest practice rules abrogate any perceived shortcomings in Oregon's riparian protections on private forestland and are sufficient to address both aquatic species habitat concerns as well as water quality concerns, and that the Adaptive Management process will ensure that any shortcomings or changes in our understanding of the science will be timely addressed.

However, we fear that the draft TMDL and the accompanying draft Water Quality Management Plan (WQMP) do not give ODF the operational flexibility to let the new rules take effect and for the Adaptive Management process to be put into practice to address any remaining water quality concerns or questions. This lack of flexibility is demonstrated in at least two ways (aside from the prescriptive numeric shade targets that we address, above).

a. DEQ Assumes FPA Inadequacy in Contravention of Legal Standard in State Statute

In Section 5.2 of the draft WQMP, DEQ addresses existing implementation plans and, in subsection 5.2.1, specifically addresses ODF and the adequacy of the FPA to meet TMDL load allocations. In particular DEQ states that "forest operations conducted in accordance with the Forest Practices Act and other voluntary measures are *generally considered* to be in compliance

with water quality standards,” and that implementation of the revised FPA rules “*may* be effective at meeting shade allocations,” but that “[t]hese rules are *not expected* to result in after-the-fact restoration of riparian areas harvested under previous rules,” and “effective shade is *likely to be deficient* for those...areas adjacent to small and medium [SSBT] streams harvested prior to implementation of the new rules” (emphasis added).

This language is problematic in two regards. First, it directly contravenes the standard established by statute in ORS 527.770. That section states, without qualification, that “[a] forest operator conducting, or in good faith proposing to conduct, operations in accordance with best management practices currently in effect shall *not be considered in violation of any water quality standards*” (emphasis added). It is true that OAR 240-042-0080(2) contains a provision allowing the EQC to petition the Board of Forestry for a review of all or part of the FPA rules implementing a TMDL if a deficiency is suspected, but this qualified exception must not be allowed to swallow the default rule, which is that the FPA is deemed adequate to meet water quality standards.

Second, the language implying a presumed inadequacy – right out the gate – of the revised FPA rules to *restore* areas harvested under the old forest practice rules is a premature conclusion that completely ignores the fact that, even under the old rules, landowners were required to replant harvested acres (including riparian areas) and that any uncovering of stream segments resulting from harvest was therefore mitigated over time as those harvested areas regrew. The new FPA rules do not change that mandatory regeneration paradigm. In other words, not only are previously harvested areas *guaranteed* to be restored, but the new rules impose even greater restrictions on harvesting in riparian areas, thereby guaranteeing that the impacts of *future* harvests will be greatly reduced.

We would therefore request that DEQ amend the language in 5.2.1 of the WQMP as follows (removed language indicated by strikethrough and new language indicated in bold):

With the publication of the Private Forest Accord Report and subsequent passage of Senate Bill 1501, 1502 and HB 4055, Forest Practices Act rule revisions were adopted by the Board of Forestry in October 2022 and additional amendments are anticipated through 2025. Implementation of these rules, which include increased riparian widths and additional tree retention, ~~may be~~ **shall be deemed** effective at meeting shade allocations **pursuant to ORS 527.770**. ~~In addition, as revised rules become effective, implementation of more stringent measures to protect water quality on private forestlands are anticipated to be applied, including in the Willamette Subbasins. These rules are not expected to result in after-the-fact restoration of riparian areas harvested under previous rules. Therefore, effective shade is likely to be deficient for those riparian areas adjacent to small and medium salmon, steelhead and bull trout streams that were harvested prior to implementation of the new rules. The trajectory for providing future riparian shade on these streams is highly variable because it is based on the rules in effect at the time of harvest and the date of replanting.~~ **The effects of the revised rules on riparian areas and on water quality will be assessed over multiple years as previously harvested areas are regrown and new harvests are conducted in accordance with revised restrictions on**

~~harvest activities in riparian areas. will be needed for potential water quality improvements to be realized so that~~ **DEQ will work with ODF to develop a TMDL implementation plan focused on** ~~can evaluate~~ **the adequacy of the revised rules over time** in meeting the load allocations and surrogate measures required by the Willamette Subbasins temperature TMDL.

b. DEQ Does Not Provide the Adequate Flexibility for DMAs to Achieve Load Allocations and Meet Temperature Standards

In response to a concern that we raised in a meeting with DEQ staff on 5 February 2024 regarding what we perceived as a lack of flexibility in the TMDL and WQMP for DMAs to develop IPs that achieve the load allocations in the TMDL in a way that minimizes adverse impacts to affected landowners, DEQ asserted that the streamside evaluation language in 5.3.2 of the WQMP provides adequate flexibility and outlines a process for demonstrating progress toward the ultimate water quality objective other than through strict compliance with an effective shading requirement. Though this could be true were DEQ to remove the prescriptive shade targets as we have requested, above, if a numeric shade target is included in the TMDL, we simply do not see how the streamside evaluation process in 5.3.2 provides any alternative path for compliance to DMAs and the landowners that they regulate.

We understand that, in this TMDL, the target shade values developed under the shade surrogate concept are the regulatory targets that DMAs must meet. We ask DEQ to clarify whether and how DMAs can receive credit for stream restoration work that cools waterways when stream temperature is not the regulatory target that DMAs must meet. DEQ explained in an e-mail communication that “Basin Coordinators have understood these types of restoration activities (stream channel work, etc.) as making progress in DMA implementation plans.” (Martin, 2023). While we agree that stream restoration projects by land managers are desirable, we ask DEQ to include explicit language in the TMDL that explains how this work helps DMAs demonstrate compliance when DMAs have been assigned shade targets, not stream temperatures, as their compliance objectives.

In particular, we would ask DEQ to include clear language in 5.3.2 indicating that implementation of best management practices (including, but not limited to those outlined in subsection f. of 5.3.2) may serve as an alternative strategy to increasing effective shading to meet a prescriptive shade target in areas where such alternatives can be shown to be adequate to protect water quality or where it can be demonstrated that hitting a shade target is not determinative of achieving water quality standards in impaired waters.

Such flexibility will, we believe, be essential for ODF to implement the revised FPA and to utilize its new Adaptive Management process to address areas of ongoing concern.

Conclusion

Again, we would like to clearly state our appreciation for the willingness of DEQ staff to answer questions and provide clarification throughout this rulemaking process. We recognize the magnitude of this process and the fact that there are many constituencies beyond the forestry sector that have no doubt likewise been engaged in this rulemaking that DEQ has had to respond to. Though we had hoped that some of the concerns that we have raised in this letter would be addressed in the draft rule, we appreciate DEQ's openness to ongoing dialogue and hope that the concerns we have raised here will be addressed by the agency in the final rule that is submitted to the EQC for approval.

The forestry sector in Oregon is doggedly committed to demonstrating that the work that we are engaged with is being carried in a manner that is responsible, sustainable, and protective of the environment. This is why we were willing to engage in a multiple-year process to revise the rules governing the harvest of timber on privately-owned forestland, and it is why we are willing, through ongoing research and processes like the Adaptive Management process with ODF, to consider how we might further improve our practices going forward.

It is our hope that DEQ will recognize the good work that is being done by the forestry sector and give space for the process that has been established through ODF to work itself out. We have no doubt that, in time, it will become clear that Oregon's forest practices are unparalleled when it comes to protecting our state's water resources.

Sincerely,

A handwritten signature in black ink, appearing to read 'Tyler Ernst', written in a cursive style.

Tyler Ernst
General Counsel and Director of Regulatory Affairs
Oregon Forest Industries Council

Appendix A: References

- Allen & Dent 2001. Shade Conditions Over Forested Streams In the Blue Mountain and Coast Range Georegions of Oregon. ODF Technical Report #13.
- Bladon et al. 2016. A catchment-scale assessment of stream temperature response to contemporary forest harvesting in the Oregon Coast Range.
- Bladon et al. 2018. A multicatchment analysis of headwater and downstream temperature effects from contemporary forest harvesting.
- Fiala et al. 2006. Comparison of five canopy cover estimation techniques in the western Oregon Cascades.
- Groom et al. 2011. Response of western Oregon (USA) stream temperatures to contemporary forest management.
- Johnson et al. 2022. Macroinvertebrate responses to differing riparian treatments following forest harvest in the headwaters of Trask River watershed.
- Kaylor et al. 2017. Long-term effects of riparian forest harvest on light in Pacific Northwest (USA) streams.
- Kaylor & Warren 2017. Linking riparian shade and the legacies of forest management to fish and vertebrate biomass in forested streams.
- Kibler 2007. The Influence of Contemporary Forest Harvesting on Summer Stream Temperatures in Headwater Streams of Hinkle Creek, Oregon. M.S. Thesis, Oregon State University.
- Martin, M. RE: Willamette Subbasins and Sandy Temperature TMDL Questions. E-mail message to Rich Wildman, 12 June 2023.
- Poole & Burman 2001. An ecological perspective on in-stream temperature: natural heat dynamics and mechanisms of human-caused thermal degradation.
- Reiter et al. 2020. Summer stream temperature changes following forest harvest in the headwaters of the Trask River watershed, Oregon Coast Range.
- Teensma, P. D. A., Rienstra, J. T., & Yeiter, M. A., 1991. Preliminary reconstruction and analysis of change in forest stand age classes of the Oregon Coast Range from 1850 to 1940.
- USGS 1902. "The Forests of Oregon," Professional Paper No. 4, Series H, Forestry. Accessed online at <https://pubs.usgs.gov/pp/0004/report.pdf>.

Vanotte et al. 1980. The River Continuum Concept.

Warren et al. 2013. Comparing streambed light availability and canopy cover in streams with old-growth versus early-mature riparian forests in western Oregon.

March 1, 2024

Oregon DEQ
Attn: Michele Martin
700 NE Multnomah St., Suite 600
Portland, OR 97232-4100

Via Email: Willamette.TemperatureTMDL@deq.oregon.gov

RE: Oregon DEQ Proposed Willamette Subbasins Temperature TMDL

Dear Ms. Martin:

Thank you for the opportunity to provide comment on the Department of Environmental Quality's (DEQ) proposed Willamette Subbasins Temperature TMDL rulemaking (the "rulemaking"). These comments are being submitted on behalf of Oregon Forest & Industries Council (OFIC), which represents forestland owners and forest products manufacturers from across the state of Oregon. Together, our members provide for themselves, their families and nearly 60,000 other households via direct employment from our lands and manufacturing facilities.

OFIC has been engaged in the current rulemaking as a member of the Rulemaking Advisory Committee (RAC) where we were represented by Rich Wildman from Geosyntec. We have also had opportunities to address questions and concerns directly to the DEQ rulemaking team outside of RAC meetings, and we appreciate the open-door policy that you have maintained throughout this process. We understand that DEQ has been working on something of an expedited schedule in an effort to meet court-mandated deadlines for completion of this revised TMDL, yet notwithstanding these real time constraints, your team has been communicative and has clearly made an effort to address concerns whenever possible. For that we thank you.

It is also with respect for the tight schedule that DEQ is working on that we wish to be as direct as possible with these comments. We recognize the importance at this stage of development for offering proposed solutions to identified problems rather than just pointing out the problems themselves. To that end, we would like to raise a number of issues of concern that we have with the draft TMDL and propose tangible ways that these concerns could be addressed by the agency in the final rule. After DEQ has had an opportunity to review and digest these suggestions, we are happy to answer any clarifying questions that your team might have.

1.) The Numeric Shade Targets Should Be Removed from the Final Rule

For the first time that we are aware of, DEQ has set numerical shade targets for each jurisdiction (by Designated Management Agency) across the subject area. These targets are based on DEQ modeling that attempts to recreate what “restored” vegetative conditions would look like and therefore what degree of shading the basin-wide river and stream network would receive absent human impacts. Table 9-14 in the proposed rule reflects these effective shade surrogate measure targets and – of immediate relevance for OFIC’s private forest landowner members – assigns a numeric shade target of 96% effective shade for all private forests regulated by the Oregon Department of Forestry (ODF) in the Southern Willamette Basin.

We are concerned about the inclusion of these numeric targets for three primary reasons.

a. Numeric Shade Targets Effectively Treat Nonpoint Sources as Point Sources

The Clean Water Act (CWA) maintains a clear distinction between the regulation of point sources and nonpoint sources for purposes of allocating loading for waters that are impaired as to a given water quality criteria. Point sources that are required to operate under NPDES permits (whether individual or general) are subject to mandatory, enforceable effluent limitations that are meant to ensure that these sources do not exceed the wasteload allocations assigned to them by the DEQ. For point sources, the analysis is simple: discharges must meet numeric effluent limits in order to be in compliance with the Act. For nonpoint sources, on the other hand, a considerable amount of flexibility is provided by the Act for demonstrating compliance and achieving the load allocations written into a TMDL. However, by assigning an effective shade target to each DMA authorized by DEQ to implement the TMDL, DEQ is essentially treating each nonpoint source category as a single point source, merely swapping in a numeric shade measurement for the numeric effluent limits that would be imposed on a permitted point source.

There is a clear reason that the CWA distinguishes between point and nonpoint sources: the principles that apply to one simply do not fit the other. This is especially true when dealing with a water quality standard such as temperature. There are myriad factors that impact the temperature of water on the landscape (a fact reflected by the complexity built into the Heat Source model used by DEQ), and that complexity means that a single surrogate measure, such as shade, effects different waterbodies in different ways depending on a host of attendant factors. The draft rule ignores this, and essentially treats shade the same way as it treats effluent from a single, discreet conveyance.

b. Numeric Shade Targets Treat Temperature Impacts from Solar Radiation Flux as Uniform and Non-Attenuating

This raises a second issue with DEQ’s numeric shade targets. Even assuming that the amount of effective shade is in all instances directly correlated to the temperature of a waterbody (which may not be the case), DEQ ignores evidence suggesting that the *magnitude* of the impact of solar radiation flux is different for different waterbodies (e.g. Vannote et al. (1980); Poole and Burman (2001)) and that such impacts have been shown not to be persistent, but to attenuate over space and time (Bladon et al. (2018)). That is to say, there is abundant evidence suggesting that

uncovering a portion of a stream does not result in a persistent increase in stream temperature, but that downstream shading will attenuate upstream impacts. This casts doubt on DEQ's reliance on basin-wide shade targets as necessary and sufficient for meeting nonpoint source load allocations and calls for a more circumspect approach when it comes to addressing landscape-level loading from nonpoint sources.

c. Unresolved Questions Regarding the Accuracy of DEQ's Shade Targets Calls for Removal

Finally, as OFIC and Geosyntec have noted in the past, we have numerous concerns with the assumptions that are built into DEQ's shade model, which concerns, if validated, cast doubt on both the accuracy and achievability of DEQ's shade targets. We have raised concerns regarding the amount of natural disturbance built into DEQ's model and the distribution of that disturbance across the landscape (more on this, below). We have also raised concerns regarding the accuracy of modeled effective shade when compared with in situ measurements from published studies (e.g. Kaylor et al. (2017); Warren et al. (2013); Fiala et al (2006)). Of the major watershed studies in Oregon that we are aware of, none have demonstrated 96% effective average shade. In fact, only two of seventy-seven study sites in the Alsea, Trask, Hinkle, RipStream, ODF 2001, and Andrews studies reached 96% shade, even in dense, mature second-growth forests that, as Kaylor et al. demonstrated in their 2017 study, are consistently *more* shaded than old-growth stands (Allen and Dent, 2001; Bladon et al., 2016; Groom et al., 2011; Kibler, 2007; Reiter et al., 2020; Warren et al., 2013).

This casts serious doubt on DEQ's assessment of system potential vegetation and effective shade in a "restored" forest condition. DEQ agreed in a conversation on 5 February 2024 that its approach is conservative. We would state it more strongly: the shade targets, based on DEQ modeling of restored conditions, are unrealistic and are likely impossible to achieve. We ask DEQ to remove prescriptive shade targets from the documents and give DMAs the flexibility to develop implementation plans with targets and strategies that are realistic to industry practices, to real-world restored conditions, and to the particularities of the streams within each DMA's jurisdictional boundaries.

We further ask DEQ to update its restored vegetation estimates. We understand that these were minimally updated for this revision of this TMDL. We did not find adequate explanation for values embedded in these estimates, including the fraction of land that was modeled as disturbed. It is inappropriate to continue to use this value from an outdated analysis without further justification.

2.) If DEQ Maintains Numeric Shade Targets in the Final Rule, the Target for Private Forestlands Should Be Significantly Decreased

As already stated, we have serious concerns regarding the accuracy and feasibility of the shade target established by DEQ for ODF-managed private forestland.

a. Existing Scientific Literature Supports a Lower Effective Shade Target

A review of six published shade studies has provided us with shade data from dense, second-growth forests in Western Oregon, which provide ideal shading conditions (Allen and Dent, 2001; Bladon et al., 2016; Groom et al., 2011; Kibler, 2007; Reiter et al., 2020; Warren et al., 2013). One study took place in the H.J. Andrews Experimental Forest and was split into two datasets to represent old-growth and second-growth forests separately (Warren et al., 2013). A second study, typically referred to as the “RipStream” study, was split into two datasets to represent small and medium sized streams separately (Groom et al., 2011). Out of the 77 pre-harvest study sites examined within these eight datasets, only 2 individual sites reach a value of 96% effective shade (Figure 1). No watershed study reached an average of 96% shade, and median shade values ranged from below 85% to between 90% and 95%. There is also significant variability within datasets, even among pre-harvest streams. We expect these pre-harvest streams to be representative of the restored shade conditions that DEQ has attempted to model. It is therefore unrealistic to expect restored shade conditions to exceed the shade conditions established by these studies, and we believe the "ODF - Private" effective shade target of 96% for the Southern Willamette Basin to be practically unattainable.

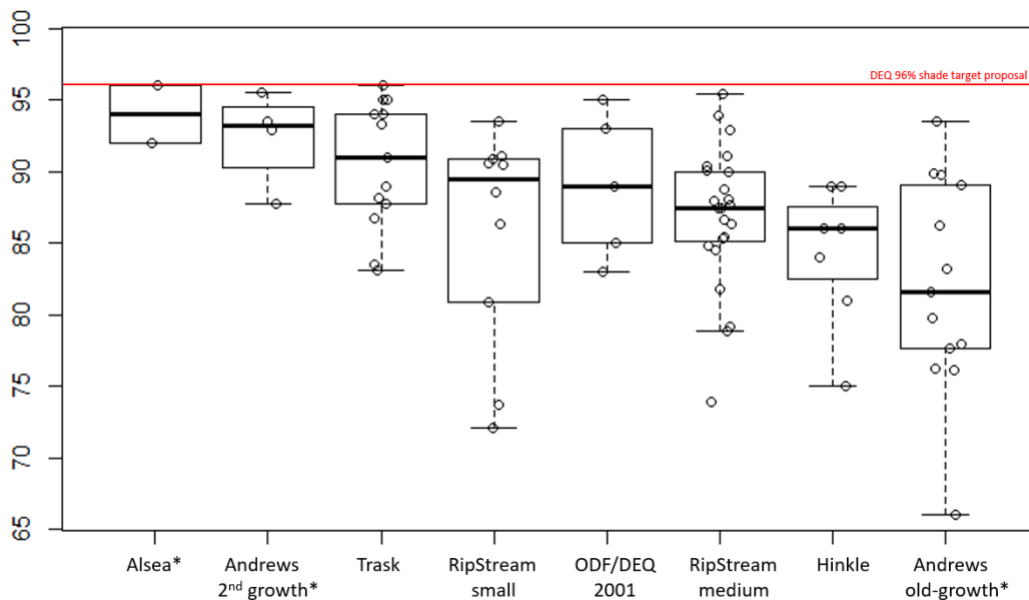

Figure 1. Distribution of effective shade values in pre-harvest streams in six major watershed studies in Western Oregon. Studies with an asterisk represent canopy closure values as opposed to hemispherical shade.

We understand from our conversation with DEQ on 5 February 2024 that the high effective shade values in the restored vegetation model, and the difference between model output and shade data from dense, second-growth forests, cannot be explained. This suggests that the model is not well calibrated at high shade values. It is therefore inappropriate for this model output to be used as a regulatory target.

We ask DEQ to reassess its model calibration to reconcile the “ODF – Private” shade target with existing effective shade data and to consider setting a more realistic shade target that aligns with effective shade values in existing mature forests (Groom et al., 2011). A simple, albeit coarse, way to do this would be to cap maximum simulated shade values between 90% and 96% effective shade for post-processing and averaging by DMA. This would be done based on understanding that greater than 96% shading is not achieved, even under ideal conditions.

b. Modeling Parameters Regarding Disturbance Should Be Changed

Further, we believe that certain modeling parameters should be changed to better reflect real-world conditions. One obvious target is the manner in which DEQ has modeled for disturbance. At present, DEQ assumes 25% disturbance and evenly distributes this disturbance across the entire watershed. There are two issues with this approach.

First, it is not clear from where DEQ’s 25% disturbance number is derived. Teensma et al. (1991) reported “at least 35%” and “probably more” of the area of the Pacific Coast Range mapped by the authors had been recently burned. While this study was for the Pacific Coast Range, and not the areas of the Willamette Subbasin TMDL encompassing the west Cascades, it appears to be the document cited in the “Appendix C” of the Technical Support Document *and* it is further supported by a 1902 USGS survey that similarly found over 33% of the forested land in Oregon west of the Cascade crest existed at that time in a recently burned-over state. It is unclear how DEQ obtained an estimate of 25% disturbance based on the Teensma study, and we specifically request that DEQ increase the assumed disturbance fraction to 35% and rerun its analysis or reduce the shade targets to account for this uncertainty.

Second, DEQ’s chosen distribution of the disturbed fraction does not match natural patterns of disturbance. Perhaps the single most common cause of disturbance in Oregon’s forest ecosystem is wildfire. Wildfire (and other natural sources of disturbance such as insect kill) cause large, contiguous patterns of disturbance while leaving areas outside of the boundaries of the fire relatively unaffected.

This runs counter to the way DEQ has modeled disturbance. DEQ has chosen to model disturbance (which, again, we believe should be set at 35% rather than 25%) dispersed evenly throughout the forestland portion of the restored conditions model, notwithstanding the fact that natural disturbances would create contiguous areas of disturbance. We recommend, therefore, that DEQ model contiguous disturbance by identifying a contiguous 35% of the stream nodes within the upland forest area and assigning all of the vegetation providing shade for these nodes the “Disturbed” model condition. Once this is done, we would ask DEQ to recalculate average shade under restored condition and make the corresponding changes to the identified shade targets and shade gaps.

To evaluate the effects of our suggested approach for modeling disturbance, we evaluated a contiguous 25% disturbance, following the approach described above. A contiguous 25% disturbance was used, rather than our recommended value of 35%, for comparison to the results

in the draft TMDL. Specifically, we evaluated this approach for an example HUC12 subbasin, Middle Mosby Creek. This subbasin was selected as an example of a subbasin covered by forestland under the restored conditions scenario.

Figure 2 indicates the modeled scenario—the nodes highlighted yellow were selected as “disturbed” and all vegetation providing shade for these nodes used the “Disturbed” forestland condition (56-foot tree height, 25% density, and 2.0-meter overhang as outlined in Appendix C of the Technical Support Document). The remaining vegetation was assigned the “No Disturbance” forestland condition (160-foot tree height, 75% density, 4.9-meter overhang).

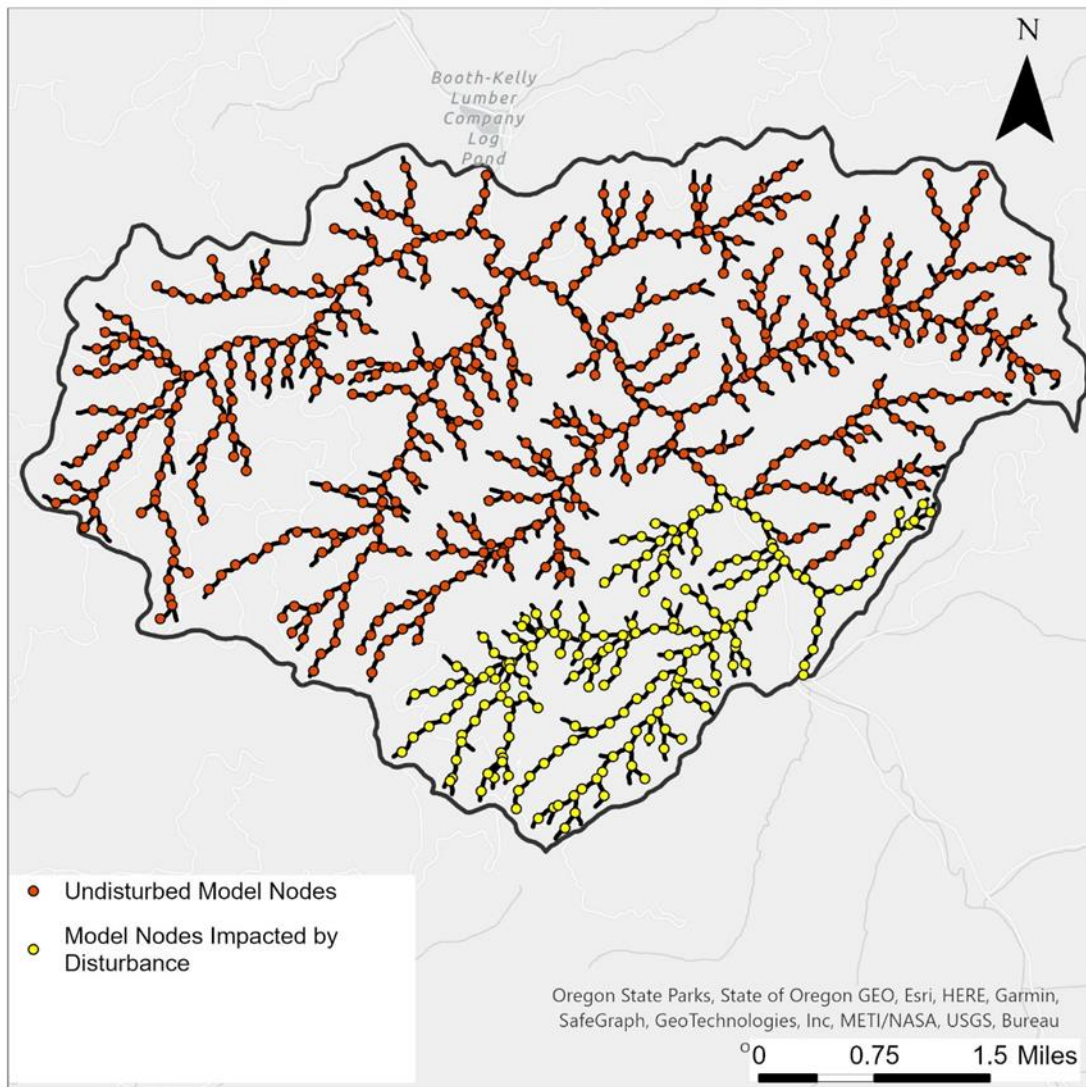

Figure 2. Middle Mosby Creek Subbasin nodes modeled as disturbed versus undisturbed.

We ran the shade model provided by DEQ for the condition described above and compared the results to the output for Middle Mosby Creek for DEQ’s restored conditions scenario. Figure 3 presents a comparison of the modeled shade. Specifically, each green dot in Figure 3 represents

a modeled node from DEQ's restored conditions scenario. There is a corresponding blue dot for each modeled node using the Contiguous 25% disturbance scenario. The figure indicates that, for many nodes, there is slightly more shade under the Contiguous 25% disturbance scenario—this is because the vegetation surrounding these nodes is fully undisturbed under the Contiguous 25% disturbance scenario, whereas there is random disturbance included in the DEQ restored conditions scenario. However, Figure 3 also shows that for nodes modeled as “disturbed,” much less shade is provided under the Contiguous 25% disturbance scenario compared with the restored conditions scenario. Importantly, these nodes do not receive 0% shade—the disturbed forestland condition described in Appendix C of the still includes 56-foot tall trees with 25% density. Nevertheless, when averaged over the modeled nodes for Middle Mosby Creek, the restored condition average from the draft TMDL method for this subbasin is **97%**, while the average using the Contiguous 25% disturbance approach is **88%**. This analysis indicates that using a more realistic approach to modeling disturbance would result in a lower, and more justifiable, shade target.

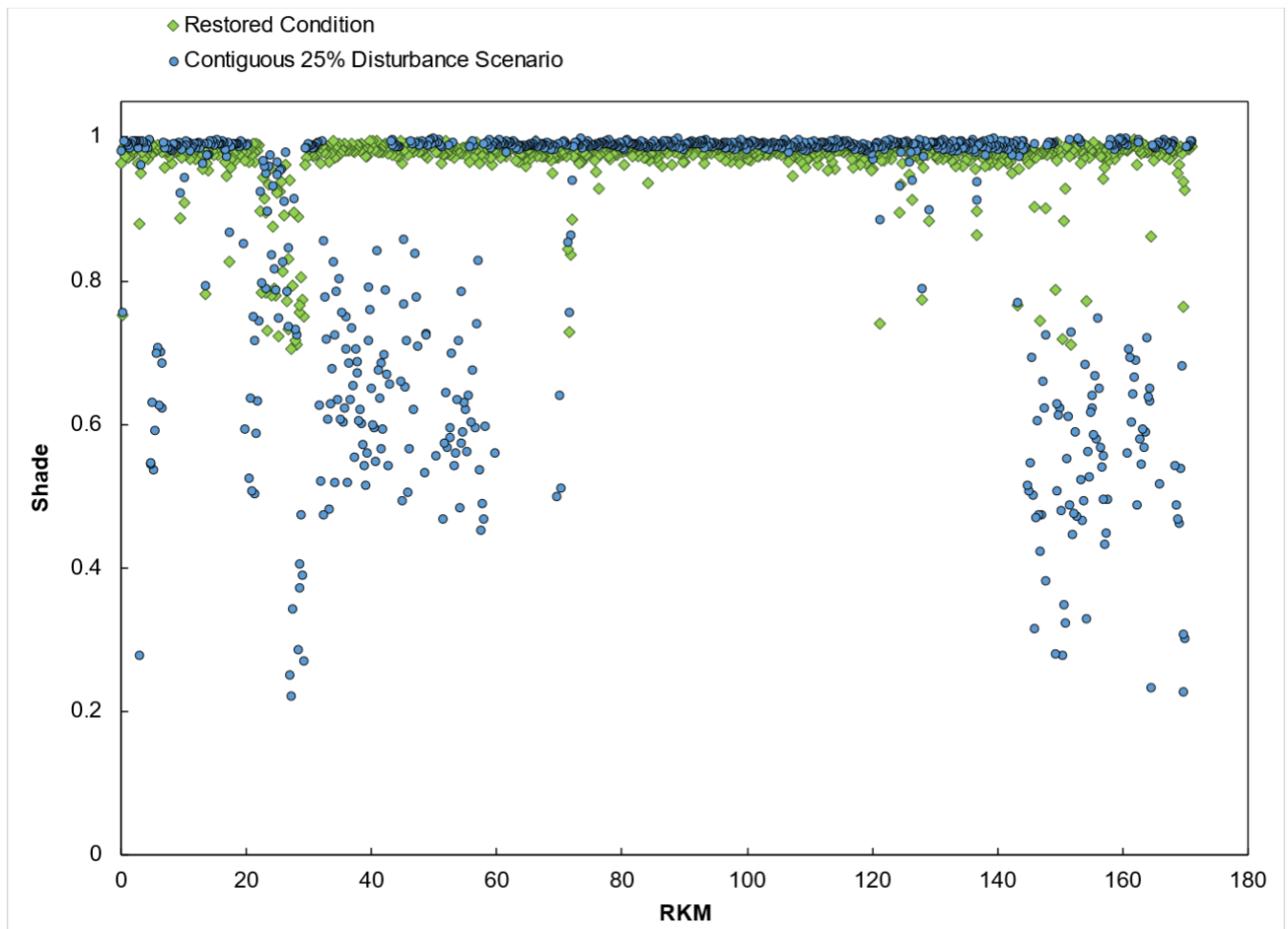

Figure 3. Comparison of DEQ Restored Conditions scenario to Contiguous 25% Disturbance "By Node" Scenario for Middle Mosby Creek.

We note again here that this example used a Contiguous 25% Disturbance, for purposes of comparison to DEQ's restored conditions scenario. However, based on our review of the literature, we request that DEQ use 35% disturbance.

c. ODEQ Should Address Divergence in Target Effective Shade Among TMDLs

As a final point of comment regarding the modeled effective shade under "restored" conditions, we observed that the target shade values in the Lower Columbia – Sandy TMDL are much lower than those in the Willamette Subbasins TMDL – more than what one would expect from natural regional variability (especially considering that the two regions even border one another). Given that these two TMDLs are being replaced concurrently, DEQ should justify these differences and explain the methodological decisions that drive them.

3.) DEQ Should Provide More Flexibility for DMAs to Demonstrate Progress Toward Attainment of Water Quality Standards in Implementation Plans

Once the TMDL is finalized and has been approved by the Environmental Quality Commission, DEQ will require DMAs to craft and submit implementation plans for how DMAs will prioritize projects and demonstrate progress toward attainment of water quality standards. OFIC is concerned, insofar as ODF is the DMA with authority to implement the TMDL on private forestland, that DEQ is unnecessarily boxing in the agency, and not leaving flexibility for ODF to deploy the new Forest Practice Act (FPA) rules and the Adaptive Management process that was established as part of the updates that were made to the FPA in 2022.

As DEQ is no doubt aware, the FPA was recently amended to, among other things, materially increase riparian management restrictions (including expanded no-harvest buffers and equipment limitation zones) in an effort to better protect aquatic species habitat on private forestland. ODF is presently in the process of implementing the new forest practice standards established pursuant to the FPA.

The new FPA rules also include a process by which any future changes to the forest practice rules would be effected through rule review by an Adaptive Management Policy Committee (AMPC), which works in conjunction with an Independent Research and Science Team (IRST) to establish studies and review scientific literature in order to assess the effectiveness of the rules in meeting environmental goals and objectives. DEQ is represented on the AMPC.

We believe that the revised forest practice rules abrogate any perceived shortcomings in Oregon's riparian protections on private forestland and are sufficient to address both aquatic species habitat concerns as well as water quality concerns, and that the Adaptive Management process will ensure that any shortcomings or changes in our understanding of the science will be timely addressed.

However, we fear that the draft TMDL and the accompanying draft Water Quality Management Plan (WQMP) do not give ODF the operational flexibility to let the new rules take effect and for

the Adaptive Management process to be put into practice to address any remaining water quality concerns or questions. This lack of flexibility is demonstrated in at least two ways (aside from the prescriptive numeric shade targets that we address, above).

a. DEQ Assumes FPA Inadequacy in Contravention of Legal Standard in State Statute

In Section 5.2 of the draft WQMP, DEQ addresses existing implementation plans and, in subsection 5.2.1, specifically addresses ODF and the adequacy of the FPA to meet TMDL load allocations. In particular DEQ states that “forest operations conducted in accordance with the Forest Practices Act and other voluntary measures are *generally considered* to be in compliance with water quality standards,” and that implementation of the revised FPA rules “*may* be effective at meeting shade allocations,” but that “[t]hese rules are *not expected* to result in after-the-fact restoration of riparian areas harvested under previous rules,” and “effective shade is *likely to be deficient* for those...areas adjacent to small and medium [SSBT] streams harvested prior to implementation of the new rules” (emphasis added).

This language is problematic in two regards. First, it directly contravenes the standard established by statute in ORS 527.770. That section states, without qualification, that “[a] forest operator conducting, or in good faith proposing to conduct, operations in accordance with best management practices currently in effect shall *not be considered in violation of any water quality standards*” (emphasis added). It is true that OAR 240-042-0080(2) contains a provision allowing the EQC to petition the Board of Forestry for a review of all or part of the FPA rules implementing a TMDL if a deficiency is suspected, but this qualified exception must not be allowed to swallow the default rule, which is that the FPA is deemed adequate to meet water quality standards.

Second, the language implying a presumed inadequacy – right out the gate – of the revised FPA rules to *restore* areas harvested under the old forest practice rules is a premature conclusion that completely ignores the fact that, even under the old rules, landowners were required to replant harvested acres (including riparian areas) and that any uncovering of stream segments resulting from harvest was therefore mitigated over time as those harvested areas regrew. The new FPA rules do not change that mandatory regeneration paradigm. In other words, not only are previously harvested areas *guaranteed* to be restored, but the new rules impose even greater restrictions on harvesting in riparian areas, thereby guaranteeing that the impacts of *future* harvests will be greatly reduced.

We would therefore request that DEQ amend the language in 5.2.1 of the WQMP as follows (removed language indicated by strikethrough and new language indicated in bold):

With the publication of the Private Forest Accord Report and subsequent passage of Senate Bill 1501, 1502 and HB 4055, Forest Practices Act rule revisions were adopted by the Board of Forestry in October 2022 and additional amendments are anticipated through 2025. Implementation of these rules, which include increased riparian widths and additional tree retention, ~~may be~~ **shall be deemed** effective at meeting shade allocations **pursuant to ORS 527.770**. ~~In addition, as revised rules become effective, implementation~~

~~of more stringent measures to protect water quality on private forestlands are anticipated to be applied, including in the Willamette Subbasins. These rules are not expected to result in after-the-fact restoration of riparian areas harvested under previous rules. Therefore, effective shade is likely to be deficient for those riparian areas adjacent to small and medium salmon, steelhead and bull trout streams that were harvested prior to implementation of the new rules. The trajectory for providing future riparian shade on these streams is highly variable because it is based on the rules in effect at the time of harvest and the date of replanting.~~ **The effects of the revised rules on riparian areas and on water quality will be assessed over multiple years as previously harvested areas are regrown and new harvests are conducted in accordance with revised restrictions on harvest activities in riparian areas.** ~~will be needed for potential water quality improvements to be realized so that~~ **DEQ will work with ODF to develop a TMDL implementation plan focused on evaluating the adequacy of the revised rules over time** in meeting the load allocations and surrogate measures required by the Willamette Subbasins temperature TMDL.

b. DEQ Does Not Provide the Adequate Flexibility for DMAs to Achieve Load Allocations and Meet Temperature Standards

In response to a concern that we raised in a meeting with DEQ staff on 5 February 2024 regarding what we perceived as a lack of flexibility in the TMDL and WQMP for DMAs to develop IPs that achieve the load allocations in the TMDL in a way that minimizes adverse impacts to affected landowners, DEQ asserted that the streamside evaluation language in 5.3.2 of the WQMP provides adequate flexibility and outlines a process for demonstrating progress toward the ultimate water quality objective other than through strict compliance with an effective shading requirement. Though this could be true were DEQ to remove the prescriptive shade targets as we have requested, above, if a numeric shade target is included in the TMDL, we simply do not see how the streamside evaluation process in 5.3.2 provides any alternative path for compliance to DMAs and the landowners that they regulate.

We understand that, in this TMDL, the target shade values developed under the shade surrogate concept are the regulatory targets that DMAs must meet. We ask DEQ to clarify whether and how DMAs can receive credit for stream restoration work that cools waterways when stream temperature is not the regulatory target that DMAs must meet. DEQ explained in an e-mail communication that “Basin Coordinators have understood these types of restoration activities (stream channel work, etc.) as making progress in DMA implementation plans.” (Martin, 2023). While we agree that stream restoration projects by land managers are desirable, we ask DEQ to include explicit language in the TMDL that explains how this work helps DMAs demonstrate compliance when DMAs have been assigned shade targets, not stream temperatures, as their compliance objectives.

In particular, we would ask DEQ to include clear language in 5.3.2 indicating that implementation of best management practices (including, but not limited to those outlined in subsection f. of 5.3.2) may serve as an alternative strategy to increasing effective shading to meet a prescriptive

shade target in areas where such alternatives can be shown to be adequate to protect water quality or where it can be demonstrated that hitting a shade target is not determinative of achieving water quality standards in impaired waters.

Such flexibility will, we believe, be essential for ODF to implement the revised FPA and to utilize its new Adaptive Management process to address areas of ongoing concern.

Conclusion

Again, we would like to clearly state our appreciation for the willingness of DEQ staff to answer questions and provide clarification throughout this rulemaking process. We recognize the magnitude of this process and the fact that there are many constituencies beyond the forestry sector that have no doubt likewise been engaged in this rulemaking that DEQ has had to respond to. Though we had hoped that some of the concerns that we have raised in this letter would be addressed in the draft rule, we appreciate DEQ's openness to ongoing dialogue and hope that the concerns we have raised here will be addressed by the agency in the final rule that is submitted to the EQC for approval.

The forestry sector in Oregon is doggedly committed to demonstrating that the work that we are engaged with is being carried in a manner that is responsible, sustainable, and protective of the environment. This is why we were willing to engage in a multiple-year process to revise the rules governing the harvest of timber on privately-owned forestland, and it is why we are willing, through ongoing research and processes like the Adaptive Management process with ODF, to consider how we might further improve our practices going forward.

It is our hope that DEQ will recognize the good work that is being done by the forestry sector and give space for the process that has been established through ODF to work itself out. We have no doubt that, in time, it will become clear that Oregon's forest practices are unparalleled when it comes to protecting our state's water resources.

Sincerely,

A handwritten signature in black ink, appearing to read "Tyler Ernst", written in a cursive style.

Tyler Ernst
General Counsel and Director of Regulatory Affairs
Oregon Forest Industries Council

Appendix A: References

- Allen & Dent 2001. Shade Conditions Over Forested Streams In the Blue Mountain and Coast Range Georegions of Oregon. ODF Technical Report #13.
- Bladon et al. 2016. A catchment-scale assessment of stream temperature response to contemporary forest harvesting in the Oregon Coast Range.
- Bladon et al. 2018. A multicatchment analysis of headwater and downstream temperature effects from contemporary forest harvesting.
- Fiala et al. 2006. Comparison of five canopy cover estimation techniques in the western Oregon Cascades.
- Groom et al. 2011. Response of western Oregon (USA) stream temperatures to contemporary forest management.
- Johnson et al. 2022. Macroinvertebrate responses to differing riparian treatments following forest harvest in the headwaters of Trask River watershed.
- Kaylor et al. 2017. Long-term effects of riparian forest harvest on light in Pacific Northwest (USA) streams.
- Kaylor & Warren 2017. Linking riparian shade and the legacies of forest management to fish and vertebrate biomass in forested streams.
- Kibler 2007. The Influence of Contemporary Forest Harvesting on Summer Stream Temperatures in Headwater Streams of Hinkle Creek, Oregon. M.S. Thesis, Oregon State University.
- Martin, M. RE: Willamette Subbasins and Sandy Temperature TMDL Questions. E-mail message to Rich Wildman, 12 June 2023.
- Poole & Burman 2001. An ecological perspective on in-stream temperature: natural heat dynamics and mechanisms of human-caused thermal degradation.
- Reiter et al. 2020. Summer stream temperature changes following forest harvest in the headwaters of the Trask River watershed, Oregon Coast Range.
- Teensma, P. D. A., Rienstra, J. T., & Yeiter, M. A., 1991. Preliminary reconstruction and analysis of change in forest stand age classes of the Oregon Coast Range from 1850 to 1940.
- USGS 1902. "The Forests of Oregon," Professional Paper No. 4, Series H, Forestry. Accessed online at <https://pubs.usgs.gov/pp/0004/report.pdf>.

Vanotte et al. 1980. The River Continuum Concept.

Warren et al. 2013. Comparing streambed light availability and canopy cover in streams with old-growth versus early-mature riparian forests in western Oregon.



795 Winter St. NE | Salem, OR 97301 | Phone: 503-363-0121 | Fax: 503-371-4926 | www.owrc.org

March 15, 2024

Rules Coordinator

Oregon Department of Environmental Quality

Submitted via email: Willamette.TemperatureTMDL@DEQ.oregon.gov

Re: Comments on Willamette Subbasins Temperature TMDL draft rules

The Oregon Water Resources Congress (OWRC) is providing comments on the Oregon Department of Environmental Quality's (DEQ) Willamette Subbasins Temperature TMDL draft rules. OWRC was a member of the Rules Advisory Committee (RAC) for the proposed rules and appreciates DEQ's time and efforts in developing the proposed rules for implementing the court-ordered replacement of temperature TMDLs in the Willamette Subbasins. We have a few concerns and comments about the proposed rules.

OWRC is a nonprofit trade association representing irrigation districts, water control districts, drainage districts, water improvement districts, and other local government entities delivering agricultural water supplies throughout Oregon. These water stewards operate complex water management systems, including water supply reservoirs, canals, pipelines, and hydropower facilities. OWRC members deliver water to approximately 600,000 acres of farmland in Oregon, which is over one-third of all the irrigated land in the state. We have several members in the Willamette subbasin and there are numerous other similar agricultural water suppliers who are currently not members.

We appreciate DEQ's recognition that our members and similar entities are not required to submit TMDL implementation plans. Our members are water suppliers charged with delivering water and providing other related services to farms and other agricultural entities and are not responsible for the quality of water delivered. As outlined in the "Draft Water Quality Management Plan – Willamette Subbasins TMDL Temperature" (WQMP) document, section 5.1.1, entities listed are not required to provide implementation plans at this time due to lack of ownership or jurisdiction over land management activities within the streamside area or are unable to implement actions listed in Table 2 of the document. We wholeheartedly agree that irrigation districts and similar entities should not be required to submit implementation plans but are concerned that the language implies this could be a requirement in the future.

The mission of the Oregon Water Resources Congress is to promote the protection and use of water rights and the wise stewardship of water resources

However, we are concerned that the documents for this TMDL still refer to irrigation districts and similar entities as Designated Management Agencies (DMA), which is completely inaccurate and baseless. Again, our districts do not have authority or jurisdiction to implement TMDLs. Secondly, the term “responsible persons” is also used incorrectly to describe irrigation districts and similar entities and is used both together and interchangeably with DMA.

Our district members are not DMAs and “responsible persons” is a nebulous and statutorily undefined term that is inappropriate to apply to irrigation districts and similar entities. We request that you revise the documents to reflect a list of entities that are not DMAs, nor responsible persons, and are not required to implement WQMPs at this time. “Water conveyance entities” has been used by DEQ previously and we would support the use of that term but we are opposed to being erroneously labeled as DMAs or responsible persons. The materials indicate the WQMP is incorporated into rule by reference and as such we request revisions occur to better reflect what was discussed in the RAC and clarify irrigation districts and similar entities are not DMAs or responsible persons for implementing TMDLs.

Your time and consideration of our comments is appreciated. Please contact me if you need any further information or to discuss further.

Sincerely,

A handwritten signature in blue ink, appearing to read 'April Snell', is positioned above the typed name.

April Snell
Executive Director



Portland General Electric
121 SW Salmon Street • Portland, OR 97204

March 12, 2024

By email: Willamette.TemperatureTMDL@DEQ.oregon.gov

Ms. Michele Martin
Oregon Department of Environmental Quality
700 NE Multnomah Street, Suite 600
Portland, OR 97232

Re: Proposed Temperature Total Maximum Daily Load and Water Quality Management Plan for the Willamette Subbasins

Dear Ms. Martin:

Portland General Electric (PGE) owns and operates the Clackamas River Hydroelectric Project (FERC Project No. 2195) located on the Oak Grove Fork and the mainstem of the Clackamas River in Clackamas County, Oregon. PGE submits the following comments on the proposed Total Maximum Daily Loads (TMDL) for Temperature in the Willamette Subbasins.

The proposed Willamette Subbasin TMDL for the Clackamas Subbasin allocates the 0.3°C human use allowance (HUA) as follows: 0.00°C for dam and reservoir operations, 0.05°C for management activities and water withdrawals, 0.02°C for solar loading from existing transportations corridors, existing buildings, existing utility infrastructure, 0.075°C for National Pollutant Discharge Elimination System (NPDES) point sources, and 0.155°C for reserve capacity. PGE's questions and concerns relate to the proposed allocation of the HUA in the Clackamas Subbasin:

- Because of recent changes in the interpretation of the scope of the NPDES permit requirement, some existing point sources within the Clackamas Subbasin may need to obtain NPDES permits. Although these existing point sources are not allocated a specific portion of the cumulative 0.075°C allocated to NPDES point sources, page 66 of the proposed TMDL states that, "[i]f DEQ determines the cumulative warming from all NPDES point sources is less than the assigned portion of the human use allowance, the remainder may be considered as reserve capacity for point sources." The proposed TMDL, however, does not identify the process or criteria for allocating this reserve capacity. Because these are existing point sources, they should have priority for the allocation of the 0.075°C NPDES point source reserve, as well as the 0.155°C general reserve, if needed. Please clarify the process and criteria for allocating the reserve capacities if these existing point sources apply for NPDES permit coverage.
- The proposed TMDL does not justify or explain the allocation of 0.00°C for existing dam and reservoir operations. With the significant presence of dams within the Willamette Basin watershed, the TMDL should provide DEQ's justification for this allocation. OAR 340-042-0040(4)(h) requires load allocations to existing nonpoint sources to be based on "best estimates of loading," and OAR 340-042-0040(6)(g) requires "reasonable assurance that the TMDL's load allocations will be achieved." "Reasonable assurance," in turn, "requires [a] determination that practices capable of reducing the specified pollutant load: (1) exist; (2) are technically feasible at

a level required to meet allocations; and (3) have a high likelihood of implementation.” *Id.* The proposed TMDL does not include any information showing that the loading from existing dam and reservoir operations is zero, nor does it provide reasonable assurance that zero loading can be achieved.

If you have any questions or feedback regarding these comments, you can contact Dan Cramer at (503) 630. 8127 or dan.cramer@pgn.com . Thank you for your consideration.

Sincerely,

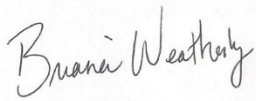
A handwritten signature in black ink that reads "Briana Weatherly". The signature is written in a cursive, flowing style.

Briana Weatherly
Hydropower FERC License Manager
Portland General Electric

February 21, 2024

Oregon DEQ
Attn: Michele Martin, Water Quality
700 NE Multnomah St., Suite 600
Portland, OR 97232-4100

Re: Draft Total Maximum Daily Load for Temperature for the Willamette Subbasins - Port of Portland Public Comments

Dear Michele Martin:

Oregon DEQ is asking for public comment on their proposed rule amendments for the Willamette Subbasins Temperature TMDL Replacement. This comment letter is submitted on behalf of the Port of Portland (Port) in response to the Oregon DEQ proposed rule amendments. The Port has both point source and nonpoint source discharges to the Columbia Slough subbasin which is one of the subbasins covered by the draft TMDL. With respect to discharges to the Columbia Slough, the Port's point source discharges are covered by an individual NPDES waste and stormwater discharge permit (permit #101647) for the Portland International Airport (which references both NPDES-IW-B15 and 1200Z permits and associated requirements), and an NPDES Municipal Separate Storm Sewer System (MS4) permit (permit #101314). The Port's nonpoint source discharges are covered by the Port's TMDL Implementation Plan which is focused on shading projects to address temperature issues in the Columbia Slough.

The comments provided here are specific to the Port and represent both point and nonpoint source discharges. In addition to these Port-specific comments, and as a member of the Oregon Association of Clean Water Agencies (ACWA), the Port adopts and incorporates by reference the Willamette River Subbasins TMDL comments submitted separately by ACWA.

Port-specific comments are as follows:

Point Source

The Port of Portland is listed in the draft TMDL document Table 7-1, as a thermal point source for the Portland International Airport's NPDES-IW-B15 permit for discharges to the Columbia Slough at river mile 2.7. In Table 9-11 of the draft TMDL document, thermal wasteload allocations (WLAs), and WLA periods are listed for point sources. Table 9-11 shows the Port has been given a WLA of zero for the period between April 1st through October 31st.

The Port's NPDES-IW-B15 permit covers, in part, discharges from the Port's operation of a facility used to treat airport deicing discharges. Discharges from this treatment facility are directed to either the Columbia River or the City of Portland's Columbia Blvd Wastewater Treatment Plant. Discharges from the deicing treatment facility do not drain to the Columbia Slough. Discharges to the Columbia Slough that are covered by this permit only include stormwater runoff. As stated in the draft TMDL (pp 23), DEQ found there is insufficient evidence to demonstrate that stormwater discharges authorized under this permit contribute to exceedances of the temperature standards.

Since only stormwater is discharged to the Columbia Slough under the NPDES-IW-B15 permit, this discharge, consistent with DEQ's findings regarding other stormwater discharges, does not contribute to the exceedances of the temperature standards in the Columbia Slough. Therefore, the Port requests that DEQ include a statement in Section 7.1 of the TMDL that only stormwater is discharged to the Columbia Slough under the Port of Portland's NPDES-IW-B15 permit and stormwater does not contribute a thermal load that causes or contributes to exceedances of the temperature standards. Additionally, since WLAs are not included for stormwater discharges, this Port permit along with the zero wasteload allocation should be removed from Table 9-11 of the draft TMDL document.

Nonpoint Source

In the draft TMDL document, Table 9-13, the Port was assigned a shade gap of 16%. As we understand, this 16% gap must be shaded by the year 2120. A large portion of Port properties are dedicated to aviation use, and as a result, must be managed in accordance with Federal Aviation Administration (FAA) rules and regulations regarding vegetation. Trees can interfere with navigational aids, create obstructions to the approach and departure surfaces, or attract wildlife towards the airfield, impacting an airport's ability to maintain safe aircraft operations. Consequently, the use of aviation properties is significantly constrained by FAA's airport land use compatibility requirements and meeting the proposed 16% increase in effective shade may not be possible and may be in conflict with federal law or policy. The Port requests that a footnote be provided for Table 9-13 stating the listed shade gaps are targets that may need to be altered based on constraints identified as part of the streamside evaluations required for the TMDL Implementation Plan (Section 5.3.2 of the TMDL WQMP).

Thank you for considering the comments listed above. If you have any questions, please contact Blake Hamalainen at 503-341-7836 or Blake.Hamalainen@PortofPortland.com .

Sincerely,
Port of Portland

Blake Hamalainen
Env Manager, Land & Water
Port of Portland

March 15, 2024

Via Email

Oregon DEQ

Attn: Michele Martin, Water Quality

700 NE Multnomah Street, Suite 600,

Portland, Oregon 97232-4100

Willamette.TemperatureTMDL@DEQ.oregon.gov

RE: SANTIAM WATER CONTROL DISTRICT COMMENTS TO THE NOTICE OF PROPOSED RULEMAKING FOR THE WILLAMETTE SUBBASINS TEMPERATURE TMDL

I. Background.

On January 10, 2024, the State of Oregon, Department of Environmental Quality (“DEQ”) released the Notice of Proposed Rulemaking, Willamette Subbasins Temperature TMDL (“Notice”). The Notice included the proposed changes to OAR 340-042-0090 (“Draft Rules”), the Draft Willamette Subbasins Total Maximum Daily Loads for Temperature, January 2024 (“Temperature TMDL”), and the Draft Water Quality Management Plan - Willamette Subbasins TMDL, January 2024 (“WQMP”). The Draft Rules incorporate the Temperature TMDL and WQMP by reference.

The Santiam Water Control District (“SWCD”) is an Oregon water control district operating under the power and authority granted to water control districts by Oregon Revised Statutes, Chapter 553 (“Statutory Authority”). SWCD is controlled by a board of directors comprised of local farmers. SWCD provides irrigation water to agricultural patrons in the North Santiam Subbasin along the North Santiam River. SWCD holds water rights to irrigate over 17,000 acres. The district boundaries overlap with the Oregon Department of Agriculture (“ODA”) Molalla-Pudding-French Prairie-North Santiam Agricultural Water Quality Management Area.

The SWCD water conveyance facilities (“SWCD Facilities”) run approximately 118 miles and consist primarily of open canals located on rights-of-way across the agricultural lands of district members. SWCD does not own the land along the SWCD Facilities. SWCD does not own or control the lands that discharge into SWCD Facilities. SWCD does not hold legal control over the water quality of discharges into SWCD Facilities.

SWCD has statutory obligations as an Oregon water control district to its patrons. SWCD submits these comments to prevent DEQ from imposing improper regulatory requirements on it so that it may fulfil its statutory obligations to its patrons without unwarranted financial and regulatory burdens.

II. SWCD Comments.

SWCD has two primary areas of concern with the Draft Rules. First, the Draft Rules incorrectly identify SWCD as a designated management agency (“DMA”). SWCD does not meet the definition of DMA because it has no regulatory or legal control over discharges into SWCD Facilities or over the streambanks adjacent to SWCD Facilities. Second, DEQ appears to ignore the Oregon Department of Agriculture (“ODA”) regulatory control over agricultural water quality by improperly including SWCD in the Draft Rules.

A. Identification of SWCD as a DMA/Responsible Person.

DEQ has improperly identified SWCD as a “designated management agency” and “responsible person” under the Draft Rules. The WQMP designates SWCD as a DMA and specifies SWCD’s “DMA Type” as a “Responsible Person” (as opposed to a City, County or Railroad). See WQMP, Table 4. DEQ’s administrative rules do not define a “responsible person.” DEQ rules define a DMA in OAR 340-042-0030(2) as “a federal, state or local governmental agency that has legal authority over a sector or source contributing pollutants, and is identified as such by the Department of Environmental Quality in a TMDL”. SWCD holds no such legal authority. Private landowners, state agencies, and other jurisdictions have legal control and regulatory authority over the canal banks along SWCD Facilities and the water quality of discharges into SWCD Facilities. SWCD does not meet the definition of DMA and (although “responsible person” is not defined) therefore logically would not meet the DMA subcategory of “responsible person.”

Because SWCD does not meet the definition of DMA, it should not be identified as one. This designation has the potential to impose a compliance obligation without extending the corresponding control over the factors necessary to achieve compliance.

DEQ should remove SWCD as a Responsible Person/DMA because, as DEQ states in the WQMP, SWCD does not have authority or control over streamside activities and cannot implement the identified management strategies. DEQ acknowledged that SWCD does not hold the legal authority to implement the WQMP management activities by including SWCD as a “Responsible Person” on Table 4: “List of Responsible Persons including Designated Management Agencies for which no TMDL implementation plan is required at this time.” The WQMP states that implementation plans are not currently required of Table 4 designees at this time because either the DMA does not have ownership or jurisdiction over land management activities within the streamside area, and so is unable to implement management strategies; or the DMA has limited streamside area under its jurisdiction. WQMP 5.1.1. SWCD agrees with this assessment as it does not have the legal authority to implement the WQMP-identified management strategies. SWCD does not own the land along the SWCD Facilities. SWCD holds easements generally for the limited purpose of operating and maintaining the SWCD Facilities.

B. ODA Authority Over Agricultural Water Quality.

ODA holds authority over water quality related to agricultural activities under the Oregon Agricultural Water Quality Management Act (ORS 568.900 to 568.933 and 561.191). In the context of TMDLs, OAR 340-042-0080(3) states:

In areas subject to the Agricultural Water Quality Management Act the Oregon Department of Agriculture (ODA) under ORS 568.900 to 568.933 and 561.191 and according to OAR chapter 603, divisions 90 and 95 develops and implements agricultural water quality management area plans and rules to prevent and control water pollution from agricultural activities and soil erosion on agricultural and rural lands. Where DEQ determines that there are adequate resources and data available, DEQ will also assign sector or source specific load allocations needed for agricultural or rural nonpoint sources to implement the load allocations. In areas where a TMDL has been approved, agricultural water quality management area plans and rules must be sufficient to meet the TMDL load allocations. If DEQ determines that the plan and rules are not adequate to implement the load allocation, DEQ will provide ODA with comments on what would be sufficient to meet TMDL load allocations. If a resolution cannot be achieved, DEQ will request the EQC to petition ODA for a review of part or all of water quality management area plan and rules implementing the TMDL.

SWCD conveys water for agricultural activities on rural lands within the Molalla-Pudding-French Prairie-North Santiam Agricultural Water Quality Management Area (“ODA Management Area”). Therefore, SWCD is subject to ODA’s jurisdiction and the ODA Management Area Rules and should not be named in the Draft Rules. Under the rule above, it is ODA and DEQ which must work together to assure that the ODA Management Area rules meet TMDL requirements.

C. Removal of SWCD from the Draft Rules.

Merely temporarily excluding SWCD from the requirement to prepare an implementation plan is not sufficient. SWCD should be removed entirely from identification in the Draft Rules because “DEQ may require implementation plans from [Responsible Persons] in the future if ownership or jurisdiction of streamside areas increases, or other data or information indicates a TMDL implementation plan is needed to achieve temperature allocations and shade targets identified in this TMDL.” *Id.* The WQMP language creates broad and undefined criteria under which DEQ may require future responsibility and create future liability for SWCD. Further, the WQMP states that “DEQ may revise the WQMP or issue individual orders to notify them of the required schedule for submitting an implementation plan.” If DEQ merely issues individual orders in the future requiring implementation plans, Responsible Persons will not have the benefit of the public notice and comment process.

Should DEQ choose to impose the described non-point source management responsibilities on SWCD in the future, these responsibilities will be unduly burdensome. SWCD does not have the resources to implement the extensive management strategies imposed on Responsible Persons. SWCD employs a district manager, an office manager, two full-time field technicians, and a GIS technician. SWCD finances are limited to the assessments and charges it imposes on its patrons.

If DEQ does not remove SWCD from identification in the Draft Rules as a DMA/Responsible Person, the Draft Rules must identify specific criteria under which DEQ may require DMAs/Responsible Persons to submit an implementation plan in the future. For example, the WQMP does not identify the threshold for what it considers to be “an increase” in ownership or jurisdiction of streamside areas. DEQ must clearly identify the criteria for when implementation plans will be required under the WQMP.

III. **Conclusion.**

SWCD appreciates the opportunity to comment and to explain why DEQ should remove SWCD as a DMA/Responsible Persons in the Draft Rules.

From: [Scott N](#)
To: [TEMPERATURETMDL Willamette * DEQ](#)
Subject: Willamette TMDL Comments
Date: Wednesday, February 28, 2024 8:33:01 PM

You don't often get email from caddis88sn@gmail.com. [Learn why this is important](#)

Hello. I would like to comment on two aspects of the Willamette TMDL, the thermal load allocations for background sources and the surrogate measures for dam and reservoir operations.

1. The thermal load allocations for background sources should be calculated using the daily average temperature for a stream attaining the relevant 7DADM-based criterion, not the criterion itself. The load allocations are expressed in terms of kilocalories/day, which should be calculated using average daily flows and average daily temperatures. By using the temperature criteria--which are based on maximum daily temperatures--in, for instance, Equation 9-2, too much heat is assigned to background sources. This type of error doesn't affect the load reductions summarized in Table 8-2 because the river's daily average temperature could reasonably be expected to cool to the same degree as the daily maximum temperature if the river were brought into compliance. It does become a factor, however, when applying the surrogate measure for dam and reservoir operations (see comment 2).
2. Regarding the surrogate measure for dam and reservoir operations (Section 9.1.4.1), If the upstream temperatures for the surrogate measure are expressed in terms of the 7DADM, then the downstream compliance point should be far enough downstream of the reservoir that the stream is able to recover its diurnal fluctuation. "The minimum duties provision states that anthropogenic sources are only responsible for controlling the thermal effects of their own discharge or activity in accordance with its overall heat contribution" (page 45). By only evaluating maximum temperature directly below a reservoir, however, not all of the thermal effects of a reservoir's discharge are accounted for. Reservoirs ordinarily release water at a constant temperature throughout the day, so the maximum temperature is also the average and minimum temperature. Much more heat can be sent downstream than is entering the reservoirs without it affecting the maximum temperature at the compliance point. Downstream of the compliance point, however, that water will reach much higher temperatures than it would have otherwise (if the minimum temperature were not essentially the same as the maximum temperature). Put another way, the kilocalories/day calculated using the daily mean temperature will be higher downstream than upstream of the reservoir. If the point of compliance is not moved far enough downstream to allow for the return of appropriate diurnal fluctuation, then the upstream measure should be based on the daily average temperature of reservoir inflows, not their daily maximum.

At the point of release, just downstream of the dam, the biological impact will also be greater than in a stream with a natural diurnal fluctuation having the same daily maximum. In the EPA Region 10 Guidance For Pacific Northwest State and Tribal Temperature Water Quality Standards (2003), the EPA makes clear in recommending, for instance, 13 degrees 7DADM for spawning salmon that their recommendation is based largely on laboratory studies using constant temperature that show impacts beginning above 12 degrees. The recommended 13 degree 7DADM criterion was assuming diurnal fluctuation (page 20). The greater the fluctuation, the more protective the criterion.

Thank you for considering my comments.

Scott N.



March 15, 2024

Oregon DEQ

Attn: Michele Martin, Water Quality
700 NE Multnomah Street, Suite 600
Portland, Oregon 97232-4100

Sent via email to Willamette.TemperatureTMDL@DEQ.oregon.gov

Re: Comments on Proposed Willamette Subbasin Temperature TMDLs

Dear Ms. Martin:

Willamette Riverkeeper, The Conservation Angler, and the Northwest Environmental Defense Center (collectively, the “Conservation Commenters”) submit the following comments on the Department of Environmental Quality’s (“DEQ”) Draft Total Maximum Daily Loads for the Willamette Subbasins for Temperature (the “draft TMDLs”).¹

SUMMARY

The draft TMDLs require major revisions because they violate Oregon’s water quality rules. If DEQ fails to remedy the violations described in these comments, the public will lose faith in DEQ’s commitment to enforce publicly adopted rules, including the Three Basin, Human Use Allowance, and TMDL Rules. OAR 340-041-0350, 340-041-0028(12)(b)(B), 340-041-0030 - 0040. DEQ must revise the draft TMDLs to correct the legal flaws identified in these comments before submitting them to the Environmental Quality Commission (“EQC”) for adoption.

The draft TMDLs violate the Three Basin Rule by allocating unlawful waste load allocations (WLAs) to four fish hatcheries. OAR 340-041-0350. The rule does not permit DEQ to increase thermal load limitations for existing facilities with National Pollutant Discharge System Elimination System (“NDPES”) permits in the McKenzie River (above river mile 15), North Santiam River, and Clackamas River Subbasins. OAR 340-041-0350(1). The Leaburg, McKenzie River, Marion Forks, and Eagle Creek Hatcheries are existing facilities that discharge in these subbasins under NPDES permits. The draft TMDLs allocate new and increased WLAs

¹ DEQ, Draft Total Maximum Daily Loads for the Willamette Subbasins Temperature (2024), <https://www.oregon.gov/deq/rulemaking/pages/willamettetemptmdl.aspx>.

to these hatcheries, thereby increasing their thermal load limitations in violation of the rule. *Id.* To comply with the rule, DEQ must remove these proposed WLAs from the draft TMDLs.

The draft TMDLs violate the TMDL Rule by failing to use recent 7Q10 streamflow data as the relevant critical condition for calculating WLAs for two fish hatcheries. OAR 340-042-0040(4)(j). Specifically, instead of using recent 7Q10 streamflow data identified in the Leaburg and McKenzie River Hatcheries' NPDES permit fact sheets, the draft TMDLs use higher 7Q10 streamflow levels to calculate the hatcheries' respective 7Q10 WLAs. By doing so, DEQ did not use the correct information regarding critical conditions, as required by rule. *Id.* As a result of using higher 7Q10 streamflow levels, the draft TMDLs assign the hatcheries 7Q10 WLAs that are higher than the most recent 7Q10 streamflow data indicate that they should be, thereby putting water quality and threatened beneficial uses at greater risk.

The draft TMDLs violate the Human Use Allowance Rule by failing to assign a portion of the human use allowance ("HUA") to the Leaburg Project. OAR 340-041-0028(12)(b)(B). The Leaburg Project won't be removed until the next decade. Meanwhile, the Leaburg Dam will continue to create a 345-acre-foot backwater section of the McKenzie River. Additionally, the Leaburg Canal's water rights will not be protected downstream of their current point of diversion, leaving the water held under those rights subject to diversion by downstream water users. Despite the warming impacts of damming rivers and diverting water, the draft TMDLs do not assign any portion of the HUA to the Leaburg Project, nor do they account for warming impacts caused by potential diversions of water held under the canal's water rights. Therefore, by fully assigning the HUA to other sources (e.g., Leaburg and McKenzie River Fish Hatcheries) and assigning none of it to the Leaburg Project, the draft TMDLs *ensure* that *more* than 0.3° C warming will occur in violation of the HUA Rule. *Id.*

The draft TMDLs also violate the TMDL Rule because DEQ's own statements and other facts ***do not*** demonstrate a high likelihood that TMDL implementation actions will occur, as required by the rule. OAR 340-042-0040(6)(g). The draft TMDLs rely in part on voluntary riparian restoration actions to achieve necessary reductions in solar loading, but DEQ admits that there "are **no or few assurances** that voluntary landowner action will be able to bridge the gap between current and needed riparian condition and function."² Additionally, DEQ explains that the "[Oregon Department of Agriculture] has also not been able to adequately incorporate or implement water quality priorities as identified in the 2006 TMDL or as part of the Biennial Review process."³ DEQ does not explain why it believes landowners will change their behavior, nor does DEQ explain why requiring designated management agencies ("DMAs") to write new implementation plans will solve the problem of such plans not being implemented. Based on these facts, DEQ cannot demonstrate a high likelihood that the draft TMDLs, if adopted, will be implemented, as required by rule. *Id.* Therefore, the draft TMDLs violate the TMDL Rule. *Id.*

The draft TMDLs also violate the TMDL Rule by failing to incorporate climate change predictions in the seasonal variation and critical conditions analyses. OAR 340-042-0040(4)(j). Although DEQ seems to admit that climate change is increasing stream temperatures via rising

² DEQ, Draft Total Maximum Daily Loads for the Willamette Subbasins Technical Support Document at 138 (2024) (emphasis added).

³ *Id.*

air temperature and decreasing stream flows, the draft TMDLs do not account for these impacts in the loading capacity, load allocations, or margin of safety sections of the draft TMDLs, thereby eviscerating their accuracy. DEQ also seems to recognize that models are available to analyze how predicted climate change impacts will affect loading capacity and solar load reduction benefits, yet DEQ chose not to use such models when preparing the draft TMDLs. Therefore, by incorrectly assuming seasonal variation and critical conditions will not change from current conditions, the draft TMDLs will not achieve water quality in the future because the assumptions they are based on are stuck in the present. As a result, the draft TMDLs will not attain and maintain water quality standards, as required by rule. OAR 340-042-0030(15).

By allocating none of the HUA to climate change – which DEQ admits is a background source that is warming stream temperatures – the draft TMDLs overallocate loading capacity to other sources in violation of the TMDL and HUA Rules. OAR 340-042-0040(4)(d), 340-041-0028(12)(b)(B). Therefore, the draft TMDLs violate these rules. *Id.*

Lastly, the draft TMDLs fail to account for predicted climate change impacts in the margin of safety in violation of the TMDL Rule. OAR 340-042-0040(4)(i). Climate change impacts are certain to affect the draft TMDLs, yet DEQ does not even treat these impacts as an uncertainty that may affect the draft TMDLs. The scientific literature demonstrates that it is feasible through modelling to quantify the uncertainties that climate change imposes on estimating pollutant loads, which DEQ seems to recognize is possible. Because DEQ did not account for climate change in the margin of safety, which it can feasibly quantify with available models, the draft TMDLs violate the TMDL Rule. *Id.*

I. THE WASTELOAD ALLOCATIONS FOR THE LEABURG, MCKENZIE RIVER, MARION FORKS, AND EAGLE CREEK FISH HATCHERIES VIOLATE THE THREE BASIN RULE

The draft TMDLs assign WLAs to four fish hatcheries that increase the hatcheries' thermal load limitations in violation of the Three Basin Rule. OAR 340-041-0350. These hatcheries include the Leaburg Fish Hatchery, McKenzie River Fish Hatchery, Marion Forks Fish Hatchery, and Eagle Creek National Fish Hatchery (collectively, the “Three Basin Hatcheries”).⁴ To comply with the Three Basin Rule, DEQ must eliminate these WLAs.

A. The Draft TMDLs Assign New and Increased WLAs to the Three Basin Hatcheries

Under the current TMDLs, the Leaburg, McKenzie River, and Marion Forks Fish Hatcheries do not have any WLAs and, therefore, they cannot discharge any excess thermal load (“ETL”).⁵ The current TMDL for the Clackamas Subbasin assigns the Eagle Creek Fish Hatchery WLAs of 3.91E+6 kcals/day (spawning period) and 4.4E+6 kcals/day (core cold water period) and, therefore, this hatchery is authorized to discharge some ETL.⁶

⁴ DEQ, *supra* n. 1 at 42-43; DEQ, *supra* n. 2 at 102-103.

⁵ DEQ, Willamette Basin TMDL: Temperature (2006); DEQ, Willamette Basin TMDL: North Santiam Subbasin (2006).

⁶ DEQ, Willamette Basin TMDL: Clackamas Subbasin at 6-36 (2006).

The draft TMDLs assign *new* WLAs to the Leaburg, McKenzie River, and Marion Forks Fish Hatcheries, thereby authorizing these hatcheries to discharge ETL for the first time.⁷ The draft TMDLs also increase the Eagle Creek Fish Hatchery’s WLA to 36.162E+6 kcals/day, which is approximately eight to nine times higher than the hatchery’s current WLAs.⁸

Table 1. Comparison of WLAs in Current TMDLs and Draft TMDLs⁹

	Current TMDLs	Draft TMDLs	
Leaburg Fish Hatchery	None (0 kcal/day)	<u>Period</u> 5/1 – 6/15 6/15-9/1 9/1 – 10/31	<u>WLA (kcal/day)</u> 363.907E+6 47.089E+6 103.102E+6
McKenzie River Fish Hatchery	None (0 kcal/day)	<u>Period</u> 5/1 – 6/15 6/15-9/1 9/1-10/31	<u>WLA (kcal/day)</u> 307.781E+6 114.394E+6 167.413E+6
Marion Forks Fish Hatchery	None (0 kcal/day)	<u>Period</u> 5/1 – 10/31	<u>WLA (kcal/day)</u> 4.562E+6
Eagle Creek Fish Hatchery	3.91E+ 6 (spawning) 4.4E+6 (core cold water)	<u>Period</u> 5/1-10/31	<u>WLA (kcal/day)</u> 36.162E+6

B. The Three Basin Rule Applies to the Three Basin Hatcheries

The Three Basin Rule applies to the Three Basin Hatcheries because the hatcheries discharge into subbasins covered by the rule. The rule applies to the McKenzie River (above river mile 15), North Santiam River, and Clackamas River Subbasins (the “Subbasins”). OAR 340-041-0350(1). The Leaburg and McKenzie River Fish Hatcheries discharge to the McKenzie River above river mile 15.¹⁰ The Marion Forks Fish Hatchery discharges to Horn Creek, a tributary of Marion Creek, which flows into the North Santiam River.¹¹ The Eagle Creek National Fish Hatchery discharges to Eagle Creek, a tributary of the Clackamas River.¹² Therefore, the Three Basin Hatcheries discharge into the Subbasins and, as a result, these hatcheries are within the geographic scope of the rule. *Id.*

⁷ DEQ, *supra* n. 1 at 42-43.

⁸ *Id.* at 43.

⁹ DEQ, Willamette Basin TMDL: Temperature at 6-36 (2006); DEQ, *supra* n. 7 at 42-43.

¹⁰ See National Pollutant Discharge Elimination System Waste Discharge Permit #101914 (eff. Nov. 1, 2021) at 1 (showing the receiving stream as the McKenzie River at RM 33.7) and National Pollutant Discharge Elimination System Waste Discharge Permit #101918 (eff. Nov. 1, 2021) at 1 (showing the receiving stream as the McKenzie River at RM 31.7).

¹¹ DEQ, NPDES Permit Evaluation and Fact Sheet for NPDES Permit #101917 at 1 (2005) (describing that Marion Forks Fish Hatchery as discharging to “Horn Creek and the North Santiam River at River Mile 72.1”).

¹² See DEQ *supra* n. 2 at 36 (describing the Eagle Creek National Fish Hatchery as the only individual NPDES point source discharging to Eagle Creek).

C. The Three Basin Rule Prohibits New and Increased Thermal Discharges from the Three Basin Hatcheries

The Three Basin Rule prohibits new and increased waste discharges in the Subbasins, except as specifically provided in the rule. OAR 340-041-0350(1). The rule defines “waste discharges” to include discharges that require NPDES permits. OAR 340-041-0350(3)(a). Discharging heat from a point source to a navigable water requires an NPDES permit. Therefore, the rule applies to new and increased discharges of heat from point sources to the McKenzie River, Horn Creek, and Eagle Creek, which are navigable waters within the Subbasins.

The Three Basin Rule prevents DEQ from assigning new and increased WLAs for heat to existing facilities with NPDES permits that discharge in the Subbasins. OAR 340-041-0350(1). Section 5 of the rule specifically addresses increases in load limitations. OAR 340-041-0350(5). Section 5 only allows DEQ to increase certain *mass* load limitations for existing facilities with NPDES permits; it does not allow DEQ to increase *thermal* load limitations for existing facilities with NPDES permits. *Id.* Specifically, section 5 of the rule does the following: (1) it authorizes DEQ to renew or transfer NPDES and Water Pollution Control Facility permits for existing facilities; (2) it specifies that existing facilities with NPDES permits may not be granted increases in their permitted mass load limitations; and (3) it lists several restrictions and exceptions to these terms, including an exception to the rule against increasing mass load limitations for existing facilities with NPDES permits. *Id.*

The only exception in section 5 of the Three Basin Rule that applies to load limitations provides that “additional industrial, confined animal feeding operations, or domestic waste loads that are irrigated on land at agronomic rates or that otherwise meet the conditions of section (7) of this rule is not be considered to be an increase in the permitted wasteload.” OAR 340-041-0350(5)(c). Section 7 of the rule only applies to “long-term general and individual stormwater permits.” OAR 340-041-0350(7). Therefore, the Three Basin Rule only permits: (1) increased *mass* load limitations related to additional industrial, confined animal feeding operations, or domestic waste loads that are irrigated on land at agronomic rates; and (2) increased *mass* load limitations related to general and stormwater permits that meet certain requirements. OAR 340-041-0350(5). Except for these specific increases in mass load limitations, the rule does not permit any increased load limitations for existing facilities with NPDES permits, including increased thermal load limitations. Because the rule does not specifically authorize increased discharges of thermal pollution, DEQ is prohibited from increasing the thermal load limitations for the Three Basin Hatcheries. OAR 340-041-0350(1).

Even though the Three Basin Rule does not include exceptions for increasing *thermal* load limitations for existing facilities with NPDES permits, the draft TMDLs increase the Three Basin Hatcheries’ thermal load limitations by assigning them new or increased WLAs for heat. These hatcheries are existing facilities under the rule because they were built before 1994.¹³ OAR 340-041-0350(3)(c) (defining an existing facility as “those for which construction started prior to January 28, 1994”). These hatcheries have NPDES permits that include water quality-

¹³ The Eagle Creek Hatchery was built in 1956 (with additions in 1965 and 1975); the Leaburg Hatchery was built in 1953; the Marion Forks Hatchery was built in 1951; and the McKenzie River Hatchery was built in 1938 and then rebuilt in 1975.

based effluent limitations (“WQBEL”) for heat discharges.¹⁴ For example, the Leaburg and McKenzie River Hatcheries’ NPDES permits include WQBELs of “no heat (0 kcal/day).”¹⁵ Because these hatcheries are existing facilities that discharge under NPDES permits in the Subbasins, DEQ cannot increase the Three Basin Hatcheries’ thermal load limitations by issuing them new and increased WLAs for heat. Therefore, the proposed WLAs for the Three Basin Hatcheries violate the rule. OAR 340-041-0350(1), (5).

The draft TMDLs directly violate the Three Basin Rule by issuing new and increased WLAs for the Three Basin Hatcheries. *Id.* Clean Water Act regulations define WLAs as a type of WQBEL. 40 CFR § 130.2(h). Therefore, by granting the hatcheries new and increased WLAs for heat, the draft TMDLs directly weaken the hatcheries’ WQBELs for thermal discharges, thereby allowing the hatcheries to discharge *more* thermal pollution. Therefore, the draft TMDLs violate the rule on the face of the draft TMDLs. OAR 340-041-0350(1), (5).

If adopted, the draft TMDLs will also violate the Three Basin Rule during implementation of the TMDLs. DEQ must include WQBELs in NPDES permits that are consistent with the assumptions and requirements of any available WLA. 40 CFR § 122.44(d)(vii)(B). By assigning new or increased WLAs to the Three Basin Hatcheries, the draft TMDLs increase the thermal load limitations for these existing facilities. These increases will be reflected in the hatcheries’ NPDES permits when DEQ reissues or modifies them to include WQBELs that are consistent with the assumptions and requirements of the new and increased WLAs. *Id.* Therefore, the draft TMDLs violate the rule’s prohibition against increasing thermal load limitations for existing facilities with NPDES permits. OAR 340-041-0350(1), (5).

As a result of the new and increased WLAs and destined changes to the Three Basin Hatcheries’ NPDES permits, the Leaburg, McKenzie River, and Marion Forks Hatcheries will go from being *prohibited* from discharging any ETL to being *permitted* to collectively discharge tens of millions of kilocalories per day. The Eagle Creek Hatchery will go from being limited to discharging 3.91E+ 6 (spawning) 4.4E+6 (core cold water) kilocalories per day to being permitted to discharge 36.162E+6 kilocalories per day. Thus, the draft TMDLs authorize these hatcheries to significantly increase temperature discharges in the Subbasins. These increases in thermal pollution are exactly the type of increased waste discharges that the Three Basin Rule is intended to prohibit, yet DEQ supports this increased thermal pollution anyway in violation of the rule. OAR 340-041-0350(1), (5). To comply with the rule, DEQ must revise the draft TMDLs by eliminating the proposed WLAs for the Three Basin Hatcheries.

¹⁴ See e.g., National Pollutant Discharge Elimination System Waste Discharge Permit #101914 at 3, Table A1 (showing permit limit for excess thermal load from April 1 – October 31 as “No heat (0 kcal/day, Max 7-day rolling Avg.”); See also National Pollutant Discharge Elimination System Waste Discharge Permit #101918 at 3, Table A1 (showing permit limit for excess thermal load from April 1 – October 31 as “No heat (0 kcal/day), 7-day rolling Avg.”).

¹⁵ *Id.*

D. DEQ Cannot Plausibly Interpret the Three Basin Rule to Allow Increased Thermal Discharges at the Three Basin Hatcheries

DEQ cannot plausibly interpret the Three Basin Rule as authorizing DEQ (or EQC) to increase thermal load limitations for the Three Basin Hatcheries. As demonstrated, the text and context of the rule prohibits increased discharges of waste, including increased discharges of thermal pollution, in the Subbasins, except as specifically provided in the rule. OAR 340-041-0350(1). Unlike the specific exceptions for mass load limitations, nothing in the text of the rule expressly or implicitly authorizes DEQ to increase thermal load limitations for existing facilities with NPDES permits. Because the rule does not specifically authorize increased heat discharges for existing facilities with NPDES permits, DEQ is prohibited from issuing new and increased WLAs to these hatcheries.

If DEQ or EQC intended for the Three Basin Rule to include exceptions for increased thermal load limitations, they would have clearly stated them in rule. The exceptions to increased mass load limitations in section 5 of the rule demonstrate that DEQ and EQC know how to expressly include increased load limitation exceptions. The absence of such exceptions for increased thermal load limitations for existing facilities with NPDES permits indicates that DEQ and EQC did not intend to include such exceptions in the rule. Therefore, unlike the exceptions to the prohibition on increasing mass load limitations, the Three Basin Rule does not carve out an exception for prohibitions on increasing other load limitations in the Subbasins, including thermal load limitations. Indeed, interpreting the rule to mean that DEQ can authorize such increases inserts language into the rule that does not exist, has not been adopted pursuant to rulemaking procedures, and, based on their demonstrated proficiency in writing clear exceptions, DEQ and EQC chose not to include.

Any alternative interpretation would also conflict with the Three Basin Rule's purpose of preserving and *improving* water quality for the *preservation* of aquatic life. OAR 340-041-0350(1) (emphasis added). Authorizing increased thermal pollution would not improve water quality in the Subbasins; it would do the opposite by reducing water quality, thereby putting thermally stressed, ESA-listed Chinook salmon and steelhead at a greater likelihood of extinction, not preservation. Therefore, DEQ cannot plausibly interpret the rule to mean that DEQ may increase the Three Basin Hatcheries' thermal load limitations.

E. DEQ Should Know that the Three Basin Rule Prohibits Increased Thermal Discharges from the Three Basin Hatcheries

DEQ should know that it cannot increase the Three Basin Hatcheries' thermal load limitations, which may explain the reason why DEQ buried the only mention of the Three Basin Rule in two sentences in the Technical Support Document (TSD).¹⁶ The TSD notes that the rule

¹⁶ DEQ, *supra* n. 2 at 39 (summarizing that “The three basin rule OAR 340-41-0350 applies to the waters of the Clackamas River Subbasin (17090011), The McKenzie River subbasin (17090004) above the Hayden Bridge (River mile 15), and the North Santiam Subbasin (17090005). The rule prohibits new or increased waste discharges with some exceptions”).

applies to the McKenzie, North Santiam, and Clackamas Rivers and that new or increased waste discharges are prohibited with some exceptions.¹⁷ The TSD does not explain these exceptions.

In contrast, the current Willamette Basin temperature TMDL explains certain exceptions to the Three Basin Rule, none of which allow DEQ to increase the thermal load limitations for the Three Basin Hatcheries – which DEQ seems to acknowledge in the current TMDLs by not granting WLAs to these hatcheries.¹⁸ In the current Willamette Basin temperature TMDL, DEQ explains that the rule “places important limitations on the allocation of additional heat to new and existing point sources in the Clackamas, Santiam, and McKenzie Subbasins.”¹⁹ According to DEQ, section 6 of the rule includes those exceptions.

“In order to preserve or improve high quality water for municipal water supplies and other uses, new or increased waste discharges are prohibited in the Clackamas River, North Santiam River, and McKenzie River above Hayden Bridge (river mile 15). However, section six of the rule does provide some exceptions for point sources of warm water regulated by general permits. These include non-contact cooling water, filter backwash and boiler blowdown. Section six also enables ODEQ to issue 401 certifications with specific conditions identified in the certification.”²⁰

Therefore, it appears that DEQ interprets the rule as prohibiting new and increased discharges of heat, except as those discharges relate to general permits for certain activities and 401 certifications. None of these exceptions apply to the Three Basin Hatcheries because they discharge under individual NPDES permits. As a result, DEQ is apparently ignoring its own interpretation of the rule by proposing WLAs for the Three Basin Hatcheries.

F. Disregarding the Three Basin Rule Harms ESA-Listed Fish

DEQ’s apparent proposal to shirk the Three Basin Rule – as well as its own interpretation of the rule – and sanction increased thermal pollution is concerning because DEQ should know that warming stream temperatures in the Subbasins are existential threats to four ESA-listed fish species. Warming stream temperatures are increasing extinction risks for Upper Willamette River spring Chinook salmon and steelhead, which spawn and rear in the McKenzie River (Chinook only)²¹ and North Santiam River (both species) as well as their tributaries. They also threaten Lower Columbia River Chinook and steelhead, which spawn and rear in the Clackamas River subbasin.²²

¹⁷ *Id.*

¹⁸ DEQ, Willamette Basin TMDL: Temperature at 4-63 (2006).

¹⁹ *Id.*

²⁰ *Id.*

²¹ The non-native hatchery summer steelhead that occur in the McKenzie River are not included in the Upper Willamette River Steelhead Distinct Population Segment.

²² *See e.g.*, Ford et al., Biological Viability Assessment Update for Pacific Salmon and Steelhead Listed Under the Endangered Species Act: Pacific Northwest at 155 (2022) (section on Lower Columbia River steelhead explaining that “most steelhead juveniles remain in freshwater for two years prior to emigration, making them more susceptible to climatic changes in temperature and precipitation”).

Despite the urgent need to protect water quality and ESA-listed fish species from increasing climate change impacts, DEQ’s priorities seem to be more aligned with allowing the Three Basin Hatcheries to avoid installing available technology that would improve water quality, protect critical habitat, and decrease harm to ESA-listed species. As DEQ may know, the Oregon Department of Fish and Wildlife (“ODFW”) hired a consultant, Lynker Corporation (“Lynker”), to analyze climate change risks to several ODFW hatcheries, including the Leaburg Hatchery.²³ Lynker found that the “Leaburg Hatchery has ongoing risks due to water temperature.”²⁴ However, Lynker found that the “hatchery has the ability to mitigate rising water temperatures within the hatchery through the use of chillers paired with a [Recirculating Aquaculture System] or [partial Recirculating Aquaculture System] setup, plus shade cover and other best practices such as reduced feeding on days with warmer water temperatures.”²⁵ Lynker did not recommend requesting a WLA to discharge more heat as a viable solution to the hatchery’s (or the river’s) water temperature challenges.

Instead of protecting water quality, DEQ proposes to grant ODFW permission to pollute more than it is currently authorized to do at the Three Basin Hatcheries. DEQ’s proposal directly conflicts with the purposes of the Three Basin Rule, which include preserving and improving water quality to preserve aquatic life, including the threatened fish species that spawn and rear in the Subbasins. OAR 340-041-0350(1). To comply with the rule and fulfill its purpose, DEQ must remove the proposed WLAs for the Three Basin Hatcheries.

G. Disregarding the Three Basin Rule is Inconsistent with Oregon Policy

DEQ’s disregard of the Three Basin Rule is not only a troubling rejection of DEQ’s rules but also of Oregon’s policy “[t]o protect, maintain and improve the quality of the waters of the state for *** the propagation of *** fish and aquatic life.” ORS 468B.015(2). The Three Basin Rule reflects the state’s resolve to meet these goals. However, DEQ seems more concerned with authorizing the Three Basin Hatcheries to pollute more rather than protecting, maintaining, and improving water quality in the Subbasins for ESA-listed fish and other beneficial uses. To comply with the Three Basin Rule and implement Oregon policy, DEQ must remove the WLAs for the Three Basin Hatcheries from the draft TMDLs.

II. DEQ USED INCORRECT 7Q10 STREAMFLOW DATA TO CALCULATE WLAs FOR THE LEABURG AND MCKENZIE RIVER FISH HATCHERIES

DEQ failed to assess seasonal variation and critical conditions in accordance with the TMDL Rule because it used inaccurate 7Q10 streamflow data to calculate the Leaburg and McKenzie River Hatcheries’ respective 7Q10 WLAs. OAR 340-042-0040(4)(j). Specifically, DEQ did not use the 7Q10 streamflow that DEQ identified in the Leaburg and McKenzie River Hatcheries’ NPDES permit fact sheets. DEQ did not explain why it used higher 7Q10 streamflow levels than the one it used three years ago in these permit fact sheets. As a result, DEQ used the wrong 7Q10 streamflow values and, as a result, incorrectly calculated higher 7Q10 WLAs for the hatcheries. Therefore, DEQ failed to comply with the TMDL Rule. *Id.*

²³ Lynker, Climate Change Risk Assessments for Select Oregon Salmon Hatcheries at 1-2 (2023).

²⁴ *Id.* at 94.

²⁵ *Id.* at 66.

A. DEQ Used the Wrong 7Q10 Streamflow Levels to Calculate 7Q10 WLAs

DEQ used incorrect 7Q10 streamflow data to calculate WLAs for the Leaburg and McKenzie River Fish Hatcheries. The NPDES permit fact sheets for these hatcheries show that the applicable 7Q10 streamflow is 781 cfs.²⁶ The draft TMDLs, however, identify the 7Q10 streamflow levels for these hatcheries as 923.3 cfs (annual), 994.5 cfs (April 1 - June 15), and 965.2 cfs (Sept 1 - Oct 15) (collectively, the “new 7Q10 flows”).²⁷ The draft TMDLs do not explain how the 7Q10 streamflow increased by as much as 142.3 cfs in just four years. Because the draft TMDLs provide no reasonable explanation for the new 7Q10 streamflow levels, DEQ’s use of these higher 7Q10 streamflow levels is erroneous.

B. DEQ’s 7Q10 Streamflow Error Caused DEQ to Miscalculate 7Q10 WLAs

DEQ’s 7Q10 streamflow error is significant because it results in an overallocation of loading capacity to the Leaburg and McKenzie River Hatcheries, which violates the TMDL rule. OAR 340-042-0040(4)(d) (“The TMDL will be set at a level to ensure that loading capacity is not exceeded”). As explained in the TSD, DEQ used 7Q10 streamflow levels to calculate 7Q10 WLAs.²⁸ Because the draft TMDLs use higher 7Q10 streamflows to calculate the Leaburg and McKenzie River Hatcheries’ respective WLAs, these WLAs are millions of kilocalories higher than they would be had DEQ used the 7Q10 streamflow level that DEQ listed in the hatcheries’ NPDES permit fact sheets. As a result of these apparent miscalculations, the draft TMDLs authorize the Leaburg and McKenzie River Hatcheries to discharge too much heat.

For example, for the period from June 15th to September 1st the draft TMDLs assign the Leaburg and McKenzie River Fish Hatcheries WLAs of approximately 47.089E+6 and 114.394E+6, respectively.²⁹ Had DEQ used the 7Q10 streamflow level that DEQ identified in the hatcheries’ permit fact sheets, the hatcheries’ WLAs during this period would be approximately 40.129E+6 and 96.995E+6, respectively.³⁰ In terms of temperature, that means that under the 7Q10 streamflow, the Leaburg Hatchery should be capped at discharging approximately 16.42° C, not 16.49° C, and the McKenzie River Hatchery should be limited to discharging approximately 19.36° C, not 19.96° C.³¹

The erroneous WLAs would cause additional harm to beneficial uses because the draft TMDLs allow point sources to discharge at their 7Q10 WLAs levels when streamflow drops below 7Q10 streamflow levels. As a result, when streamflow drops below 781 cfs, the Leaburg and McKenzie River Fish Hatcheries could respectively discharge water that is approximately 0.07° to 0.60° C warmer than the temperatures the hatcheries would have been allowed to discharge had DEQ used the 7Q10 streamflow level identified in the permit fact sheets.

²⁶ DEQ, National Pollutant Discharge Elimination System Permit Fact Sheet for Permit No. 101914 at 9 (2021); DEQ, National Pollutant Discharge Elimination System Permit Fact Sheet for Permit No. 101918 at 10 (2021).

²⁷ DEQ, *supra* n. 7 at 42-43.

²⁸ DEQ, *supra* n. 2 at 60.

²⁹ DEQ, *supra* n. 1 at 42.

³⁰ See DEQ, *supra* n. 2 at 104 (Equation 9-1).

³¹ See *Id.* at 105-106 (Equation 9-4).

If DEQ refuses to use the 7Q10 streamflow level identified in the Leaburg and McKenzie River Hatcheries' permit fact sheets (781 cfs) – or, more appropriately, a lower streamflow level based on predicted climate change impacts on streamflow – DEQ should explain why it believes the higher 7Q10 streamflow levels are appropriate for calculating the Leaburg and McKenzie River Hatcheries' respective WLAs. If DEQ complies with the Three Basin Rule by removing the unlawful WLAs for the Three Basin Hatcheries, this explanation would not be necessary.

III. THE DRAFT TMDLs DO NOT ASSIGN A PORTION OF THE HUA TO THE LEABURG PROJECT

The draft TMDLs must assign a portion of the HUA to the Leaburg Project. Although the Eugene Water & Electric Board (EWEB) voted to decommission the Leaburg Project, the facility won't be removed until the next decade at the earliest, assuming the Federal Energy Regulatory Commission approves the decommissioning plan.³² Therefore, warming caused by the impoundment, which creates “a 345-acre-foot backwater section of the McKenzie River,”³³ will continue for years. These impacts must be accounted for in the draft TMDLs.

DEQ apparently failed to assess whether the water that is apparently no longer being diverted into the Leaburg Canal is not being diverted by other water users, thereby offsetting the water quality benefits of suspending the canal's diversion. As the current TMDL describes, diverting water into the canal decreases instream flow, which increases stream warming.³⁴ Presumably, DEQ assumed that because that water is no longer being diverted into the canal, the water quality impacts associated with that activity are no longer occurring and, therefore, the portion of the HUA that is assigned to the Leaburg Project³⁵ is now available for other pollutants. That is an erroneous assumption.

There is no evidence in the draft TMDLs that DEQ considered whether the water that is no longer being diverted into the Leaburg Canal is being diverted at other points of diversion. Although EWEB has applied to transfer the canal water rights to temporary instream use, the Oregon Water Resources Department (“OWRD”) has not issued a decision on that application and, therefore, the water is not yet protected instream.³⁶ Even if approved, the application only requests instream use at the point of diversion, which would allow other water users to divert that water below the point of diversion.³⁷ Also, the application leaves the option open for EWEB to terminate the transfer upon its request.³⁸ Therefore, there is no guarantee that the water quality benefits of terminating diversions at the canal are fully occurring now or will continue to occur in the future, which DEQ seems to have falsely assumed is the case.

³² Nathan Wilk, Eugene Water and Electric Board plans to remove Leaburg Dam in 2032 at the earliest, Or. Pub. Broadcasting (Jan. 28, 2024), <https://www.opb.org/article/2024/01/28/leaburg-dam-removal-eugene-electric/>

³³ Lynker, *supra* n. 23 at 63.

³⁴ DEQ, Willamette Basin TMDL: Temperature at 4-181.

³⁵ *Id.* at 4.

³⁶ See Oregon Water Resources Department, Water Rights Information Query, https://apps.wrd.state.or.us/apps/wr/wrinfo/wr_transfer_centric.aspx?transfer_char=T&transfer_nbr=14337 (showing processing history for transfer (“T”) application number T-14337).

³⁷ See T-14337 Application at 6, available at

https://apps.wrd.state.or.us/apps/wr/wrinfo/wr_transfer_centric.aspx?transfer_char=T&transfer_nbr=14337.

³⁸ *Id.* at 7.

The draft TMDLs must retain the portion of the HUA assigned to the Leaburg Project in the current TMDL.³⁹ The impoundment it creates affects stream temperatures. Also, even if canal diversions are not resumed, other water users could be diverting water held under the canal water rights because OWRD has not approved the transfer application and, even if it does, that water will not be protected below the point of diversion. Therefore, DEQ cannot assume that the Leaburg Project's currently assigned portion of the HUA is available for other sources.

If DEQ refuses to assign a portion of the HUA to the Leaburg Project, DEQ should at least explain why it is no longer assigning a portion of the HUA to the project even though it will continue to affect water quality for at least the next decade.

IV. THE DRAFT TMDLs LACK REASONABLE ASSURANCES

DEQ cannot demonstrate a high likelihood that the draft TMDLs will be implemented because DEQ admits there are few to no assurances of landowner participation, DMAs are not implementing current implementation plans, and there are no new incentives or laws that will change these trends. The draft TMDLs also do not include adaptive management procedures that ensure loading reductions stay on track to attain and maintain water quality standards. Therefore, the draft TMDLs lack reasonable assurances in violation of the TMDL rule, and the U.S. Environmental Protection Agency ("EPA") should not approve them. OAR 340-042-0040(6)(g).

A. The Draft TMDLs Violate the Reasonable Assurances Rule

The draft TMDLs lack reasonable assurance that the proposed load allocations will be achieved. *Id.* To establish reasonable assurance DEQ must determine that the practices capable of reducing thermal loads: "(1) exist; (2) are technically feasible at a level required to meet allocations; and (3) have a ***high likelihood*** of implementation." *Id.* (emphasis added). DEQ cannot make that determination because DEQ's own statements indicate that implementation actions necessary to meet shade targets and reduce thermal loads ***do not*** have a high likelihood of implementation. Based on DEQ's statements and other facts regarding implementation of the current TMDLs, DEQ could not reasonably determine that there is a high likelihood that actions to meet shade targets and restore water quality under the draft TMDLs will be implemented or completed. Therefore, the draft TMDLs lack reasonable assurance that the proposed load allocations will be achieved. *Id.*

1. DEQ Admits There is Little, if Any, Chance that the TMDLs Will be Implemented

DEQ's own statements suggest that critical shade targets will not be achieved. DEQ explains that achieving shade targets is necessary to ensure that the no warming requirement is met for nonpoint sources, as necessary to restore water quality.⁴⁰

³⁹ DEQ, Willamette Basin TMDL: Temperature at 4-4.

⁴⁰ DEQ, *supra* n. 2 at 107.

“The load allocations provided to entities that manage or have authority over streamside vegetation management activities require those activities not cause a temperature increase (no warming). DEQ considered the difficulty in addressing this requirement where there is existing infrastructure (roads, railroads, buildings, and utility corridors) and provided a separate load allocation to these land use types to allow some warming and minimize the costs of trying to eliminate their warming impact. The no warming requirement for other land management activities is implemented through an effective shade target.”⁴¹

At the same time, DEQ acknowledges that actions to meet current shade targets are failing.

“There has been a lack of implementation of area plans to achieve TMDL allocations and there are no or few assurances that voluntary landowner action will be able to bridge the gap between current and needed riparian condition and function. [Oregon Department of Agriculture] has also not been able to adequately incorporate or implement water quality priorities as identified in the 2006 TMDL or as part of the Biennial Review process.”⁴²

Therefore, DEQ seems to admit that shade targets must be achieved to meet water quality standards, but that meeting these targets is unlikely based on low landowner participation and failures to implement the very plans that are supposed to help achieve water quality standards. Therefore, the only thing that DEQ, EPA, and the public can apparently be reasonably assured of is that the draft TMDLs will not attain and maintain water quality standards.

2. More Planning Will Not Solve Implementation Problems

DEQ’s solutions for bridging the gap between current and needed riparian condition and function will fail. For example, DEQ proposes that ODA draft a temperature TMDL implementation plan and submit it to DEQ for review.⁴³ However, DEQ does not explain how *writing a new plan* will solve the problem of ODA not implementing plans. Therefore, DEQ, EPA, and the public can only be reasonably assured that ODA might engage in a writing exercise rather than implement actions needed to restore riparian conditions and water quality.

3. DEQ Provides No Support for its Aspirations that Landowners will Participate

The draft TMDLs offer no solutions for spurring a sea change in landowner willingness to voluntarily restore riparian vegetation, which is unlikely to occur without financial incentives that outcompete profit-generating land use activities. Indeed, DEQ admits:

⁴¹ *Id.*

⁴² *Id.* at 138. *See also* DEQ, Draft Water Quality Management Plan – Willamette Subbasins TMDL Temperature at 12 (2024) (“While DEQ was not able to directly quantify the impact that planting projects documented in OWRI and the DEQ Willamette Basin Year Five Review had on modeled streamside shade gaps, available data demonstrate that the pace and scale of streamside planting will need to increase to meet shade target timelines in Table 3”).

⁴³ DEQ, *supra* n. 2 at 138.

“It is unclear what steps can be taken when landowners are in compliance with Area Rules, yet land conditions contribute to water quality standard exceedances and are unable to meet TMDL load allocations. There has been a lack of implementation of area plans to achieve TMDL allocations and **there are no or few assurances** that voluntary landowner action will be able to bridge the gap between current and needed riparian condition and function.”⁴⁴

DEQ does not explain why landowners would suddenly change their behavior simply because DEQ issued new TMDLs and designated management agencies (“DMA”) will once again draft implementation plans that, based on prior performance, will not be implemented.

4. DEQ Provides No Support for its Belief that New Laws Protecting Riparian Habitat Will be Adopted.

It is unreasonable to assume that lawmakers will suddenly start passing laws that require landowners to install riparian shade on private property, yet that is exactly what DEQ apparently assumes will occur. In estimating the timeframe for meeting shade targets, DEQ made the following assumption:

“DMAs that have a large percentage of private property within their jurisdiction will have challenges in meeting effective shade targets. It will likely take additional time to *develop more protective streamside ordinances or regulations*, work with landowners, or partner with other organizations to conduct streamside planting and restoration projects in these areas.”⁴⁵

DEQ does not explain why it is reasonable to expect DMAs to develop more protective laws during implementation of the draft TMDLs when they have failed to do so during the implementation of the current TMDLs. Based on their performance to date, it is more reasonable to assume that the DMAs will not adopt these laws, especially at the scale necessary to meet shade targets. Therefore, the draft TMDLs lack reasonable assurances that shade targets will be met or that water quality will be restored and, as a result, they violate the TMDL rule. OAR 340-042-0040(6)(g).

5. DEQ Did Not Account for Wildfires Destroying Riparian Shade

DEQ also failed to account for increasing wildfires caused by climate change, which will delay, if not prevent, the shade targets from being met. The rate of wildfires has been increasing and will continue to increase as temperatures rise. Experts predict that “[b]y 2040, the region should anticipate a 400-500% increase in the number of acres burned annually and summer flows in the Willamette River and other waterways reduced by 40-60%.”⁴⁶

⁴⁴ *Id.* (emphasis added).

⁴⁵ DEQ, Draft Water Quality Management Plan – Willamette Subbasins TMDL Temperature at 13 (emphasis added).

⁴⁶ <https://www.eugene-or.gov/ImageRepository/Document?documentId=55983> at 21. See also, Jessica E. Halofsky, et al., *Changing wildfire, changing forests: the effects of climate change on fire regimes and vegetation in the Pacific Northwest, USA*, Fire Ecology 16, 4 (2020) (“According to projections based on historical records, current trends, and simulation modeling, protracted warmer and drier conditions will drive lower fuel moisture and longer

As shade coverage declines due to wildfires and summer flows are reduced, the stream temperatures will continue to rise, yet DEQ does not take this climate change-driven increase in wildfires into consideration. To start with, DEQ needs to include conservative assumptions for wildfires in the draft TMDLs and account for them when creating a timeline for meeting shade targets. Ideally, the timeline should require shade targets to be met sooner to account for the likelihood that some shade benefits will be lost due to wildfires and will need to be replaced.

B. EPA Should Reject the Draft TMDLs for Lack of Reasonable Assurances

Unless DEQ revises the draft TMDLs to provide reasonable assurances, EPA should reject them. When EPA reviews a TMDL that includes waste load and load allocations, it determines whether there are reasonable assurances that the pollution reductions embodied in the load allocations will be achieved.⁴⁷ EPA does that because, if those reductions are not fully achieved, the cumulative reductions from all sources will not achieve the goal of the TMDL: attainment of water quality standards.⁴⁸

EPA considers multiple factors in determining whether a TMDL includes reasonable assurances. For example, EPA asks the following question: “Does the TMDL include an “assumption” that a permit based on a WLA might be reopened to include a more stringent WQBEL if attainment of nonpoint source load allocations was not achieved consistent with the TMDL’s reasonable assurance assumptions?”⁴⁹ When EPA reviews the draft TMDLs, it must answer “no” to this question because the draft TMDLs do not include a procedure for reopening permits to impose more stringent WQBELs when shade targets are not achieved. Indeed, the Water Quality Management Plan (“WQMP”) only explains that WLAs will be included in permits when they are renewed; neither the WQMP nor the draft TMDLs mention anything about modifying NPDES permits to impose stricter WQBELs when shade targets are not met.⁵⁰

Incredibly, DEQ claims that the draft TMDLs use a similar accountability framework that EPA developed for the Chesapeake Bay TMDL.⁵¹ That is wildly inaccurate for multiple reasons.

First, to ensure implementation plans meet their targets, the Chesapeake Bay TMDL lists multiple actions EPA could take to ensure pollutant reductions occur. For example, these actions include “revising the final December 2010 Chesapeake Bay TMDL to reallocate additional load reductions from nonpoint to point sources of nitrogen, phosphorus, and sediment pollution, such as wastewater treatment plants.”⁵² The draft TMDLs do not provide a similar procedure when

fire seasons in the future, likely increasing the frequency and extent of fires..., [r]eburns are also likely to occur more frequently with warming and drought, with potential effects on tree regenerations and species composition”).

⁴⁷ U.S. Env’t Prot. Agency, Chesapeake Bay Total Maximum Daily Load for Nitrogen, Phosphorous and Sediment at 7-1 (2010), https://www.epa.gov/sites/default/files/2014-12/documents/cbay_final_tmdl_section_7_final_0.pdf.

⁴⁸ *Id.*

⁴⁹ Email from Denise Keehner, U.S. Env’t Prot. Agency, to Alex Strauss, U.S. Env’t Prot. Agency et al. at 3 (Feb. 15, 2012), https://www.epa.gov/sites/default/files/2020-07/documents/supplemental_information_for_tmdl_reasonable_assurance_reviews_feb_2012.pdf

⁵⁰ DEQ, Draft Water Quality Management Plan – Willamette Subbasins TMDL Temperature at 11.

⁵¹ *Id.* at 41.

⁵² U.S. Env’t Prot. Agency, *supra* n. 47 at 7-12.

shade reduction targets are not met. Indeed, the draft TMDLs do not suggest reallocating load reduction responsibilities from nonpoint to point sources when shade targets are not met. Therefore, unlike the Chesapeake Bay TMDL, the draft TMDLs do not ensure that sources stay on track toward meeting the goals of attaining and maintaining water quality standards.

Second, the Chesapeake Bay TMDL includes a more aggressive timeline for reducing nonpoint source pollution than the draft TMDLs. For example, the Chesapeake Bay TMDL's "goal for installing all controls necessary to achieve the Bay's DO, water clarity, SAV, and chlorophyll a criteria is 2025."⁵³ Additionally, "EPA ... provided an interim goal that 60 percent of the reductions to achieve applicable WQS occur by no later than 2017."⁵⁴ According to the Chesapeake Bay TMDL, that goal "ensures that the large portions of necessary reductions, or the more difficult restoration actions, are not left until the later years of the restoration schedule."⁵⁵

The draft TMDLs do not require installation of riparian revegetation projects needed to meet shade targets. Therefore, unlike the Chesapeake Bay TMDL, the draft TMDLs do not require progress in implementing actions needed to attain and maintain water quality standards.

Third, the Chesapeake Bay TMDL requires jurisdictions to "commit to set and meet specific 2-year milestones for implementing practices to achieve load reductions."⁵⁶ Jurisdictions must "achieve each successive set of 2-year milestones and their respective target loads by having appropriate controls in place pursuant to the strategies identified in the jurisdiction's [implementation plans] and 2-year milestones."⁵⁷

The draft TMDLs only require DMAs to write about meeting milestones and describe how they might go about doing that; they do not require the DMAs to meet these milestones. Therefore, unlike the Chesapeake Bay TMDL's framework, the draft TMDLs' discussion of milestones is aspirational, not accountable.

Fourth, the Chesapeake Bay TMDL uses a TMDL tracking and accountability system that enables users to determine progress toward the final TMDL allocations and meeting the 2-year milestones.⁵⁸ The draft TMDLs do not call for such a system, thereby making draft TMDLs' implementation less transparent and accountable to the public than the Chesapeake Bay TMDL's implementation.

DEQ must revise the draft TMDLs to include reasonable assurances that shade targets will be met. If DEQ wants the draft TMDLs' accountability framework to be like the Chesapeake Bay TMDL's framework, DEQ should at least require ODA and other entities with management authority over land use to develop two-year implementation plans that set two-year milestones for implementing riparian revegetation projects. DEQ should also revise the draft TMDLs to provide that DEQ will impose more restrictive WLAs for NPDES sources when the DMAs fail

⁵³ *Id.* at 7-2.

⁵⁴ *Id.*

⁵⁵ *Id.*

⁵⁶ *Id.*

⁵⁷ *Id.* at 7-12.

⁵⁸ *Id.* at 7-10.

to meet their two-year milestones. Also, DEQ should revise the draft TMDLs to provide for a web-based tracking tool that enables the public to track progress toward meeting the draft TMDLs goals, if any.

V. DEQ FAILED TO ACCOUNT FOR PREDICTED CLIMATE CHANGE EFFECTS

Conservation Commenters recognize that no agreed upon methodologies for incorporating climate change predictions into TMDLs exist yet. However, this lack of consensus does not excuse DEQ from failing to incorporate climate change predictions at all into its assessment of loading capacity, underlying WLA and load allocations (“LA”), margin of safety, or implementation strategies. Indeed, EPA now recognizes that TMDLs built upon steady-state assumptions are no longer accurate.

“While many temperature TMDLs have been established, the supporting analyses have generally assumed a stationary climate under which historical data on flow and air temperature can serve as an adequate guide to future conditions. Projected changes in climate over the 21st century contradict this assumption.”⁵⁹

Indeed, EPA encourages “water quality authorities to consider climate change impacts when developing wasteload and load allocations in TMDLs where appropriate.”⁶⁰ Doing so is appropriate in this case because the scientific evidence shows that stream temperatures in the Willamette River subbasins will increase because of climate change. Because the draft TMDLs do not make any reasonable attempt to incorporate projected climate change impacts into their analyses, allocations, or assumptions regarding implementation effectiveness, the draft TMDLs rely on steady-state assumptions and, therefore, they are built to fail. As a result, the draft TMDLs will not attain and maintain water quality, as required by rule. OAR 340-042-0030(15).

DEQ did not account for predicted climate change effects when assessing seasonal variation and critical conditions in violation of the TMDL rule. OAR 340-042-0040(4)(j). The rule requires DEQ to “account[] for seasonal variation and critical conditions in stream flow, sensitive beneficial uses, pollutant loading and water quality parameters so that water quality standards will be attained and maintained during all seasons of the year.” *Id.* The best available scientific data demonstrates that climate change is decreasing streamflows, warming air temperatures, increasing stream temperatures, and harming salmon and steelhead, and that these impacts will intensify. However, despite the overwhelming evidence that these seasonal variations and critical conditions are changing due to climate change, DEQ did not account for these changes in the draft TMDLs. Instead, DEQ assumed that steady state conditions will continue, which is an erroneous assumption according to EPA, and it conflicts with the overwhelming weight of scientific evidence on expected climate change impacts.⁶¹

⁵⁹ U.S. Env’t Prot. Agency, Final Project Report: EPA Region 10 Climate Change and TMDL Pilot – South Fork Nooksack River, Washington. EPA/600/R-17/281. U.S. Env’t Prot. Agency, Nat’l Health and Env’tl Effects Research Lab., Western Ecology Division, Corvallis, OR at 1 of unpaginated abstract (2016).

⁶⁰ U.S. Env’t Prot. Agency, National Water Program 2012 Strategy: Response to Climate Change at 7, 57, 109 (2012).

⁶¹ U.S. Env’t Prot. Agency, *supra* n. 59 at 1.

For example, climate change impacts are anticipated to occur on the McKenzie River, where the draft TMDLs unlawfully authorize increased thermal pollution from the Leaburg and McKenzie River Hatcheries. An expert consultant retained by ODFW to assess the Leaburg Hatchery's climate change-related risks reported the following climate change impacts to the McKenzie River:

- “Climate change projections of water temperature in the McKenzie River estimate increases of approximately 1.1°C in June, 1.6°C in July, 1.3°C in August, and 0.8°C in September by 2045 (Chandler et al. 2016; Isaak et al. 2016).”⁶²
- “Streamflow on the McKenzie River near the [Leaburg Hatchery] is projected to decrease up to 38% in September with an average decrease of 28% during summer and fall months (June through October) in 2045 using RCP8.5 (high emissions scenario).”⁶³
- “The timing of peak and minimum flows on the McKenzie River is not anticipated to shift by mid-century (2030-2059) with climate change, but the magnitude of peak and minimum flows is expected to change in nearby gages, with *** low summer flows from June through October decreasing by up to 38%.”⁶⁴
- “The Fifth Oregon Climate Assessment projects statewide air temperature increases of 4.5-6.3°F in the summer, with smaller increases during the rest of the year. The average annual temperature increase statewide at mid-century (2040-2069) is estimated to be 3.6°F for RCP4.5 and 5.0°F for RCP8.5 (Dalton and Fleishman, 2021).”⁶⁵

DEQ did not incorporate this information when determining the McKenzie River's loading capacity or the WLAs for the Leaburg and McKenzie River Fish Hatcheries, even though this information is apparently relevant to making management decisions for the Leaburg Hatchery.

Had DEQ considered this relevant information regarding seasonal variation and critical conditions for the McKenzie River the same way that a consultant considered it for a fish hatchery, DEQ should have realized that the HUA will be consumed by climate change, leaving no loading capacity left to assign to the Leaburg and McKenzie Hatcheries. Because DEQ did not incorporate this information in the draft TMDLs, DEQ overallocated loading capacity to these hatcheries, and, as a result, the draft TMDLs will not attain or maintain water quality standards in the McKenzie River, as required by rule. OAR 340-042-0030(15).

DEQ failed to conduct the requisite loading capacity analysis for all of the Willamette subbasins even though DEQ admits that climate change impacts are affecting stream temperatures throughout this area.⁶⁶ What's more, DEQ failed to perform this analysis despite its

⁶² Lynker, *supra* n. 23 at 66.

⁶³ *Id.* at 64.

⁶⁴ *Id.* at 63.

⁶⁵ *Id.* at 61.

⁶⁶ DEQ, Draft Total Maximum Daily Loads for the Willamette Subbasins Technical Support Document Appendix G: Climate Change and Stream Temperature in Oregon: A Literature Synthesis at 18 (2024) (“The Pacific

explanation in the draft TMDLs that models are being used to assess how climate change will impact water quality in the future.⁶⁷ Thus, DEQ acknowledges that technology is available to assess predicted climate change impacts on loading capacity and the effects of restoring shade on attaining and maintaining water quality – DEQ just decided not to use that technology for unexplained reasons.

DEQ also did not discuss climate change effects on sensitive beneficial uses such as Upper Willamette River spring Chinook salmon and steelhead and Lower Columbia River Chinook and steelhead, which are threatened with extinction, in part, because of thermal pollution.⁶⁸ Because DEQ failed to account for these issues using models that DEQ acknowledges are available, DEQ failed to adequately consider seasonal variation and critical conditions. As a result, DEQ violated the TMDL Rule. OAR 340-042-0040(4)(j).

The draft TMDLs will not attain or maintain water quality because DEQ did not account for predicted climate change impacts. No reasonable person could believe, based on the scientific evidence, that WLAs and LAs based on current conditions will be sufficient - along with implementation of shade targets - to achieve water quality standards in a future that will be hotter and drier. Because climate change will undoubtedly affect seasonal variation and critical conditions, DEQ's complete failure to account for climate change at all in its loading capacity analysis, TMDL allocations, and other TMDL elements violates the TMDL Rule. *Id.*

A. DEQ Failed to Consider Future Climate Change Impacts on Streamflow

The draft TMDLs' incomplete literature review on climate change indicates that DEQ is aware that climate change affects streamflow and that lower streamflow affects stream temperature.⁶⁹ For example, DEQ acknowledges that lower streamflow reduces thermal capacity and increase sensitivity to air temperature.⁷⁰ DEQ also explains that this is “especially relevant to temperature TMDLs, where the period of interest is the coincidence of summer low-flows and high air temperatures.”⁷¹ DEQ also summarizes multiple studies that found declining stream discharge trends in the Western U.S. and Oregon and notes several studies that predict streamflows will continue to decrease.⁷² For example, DEQ cites Chen & Chang (2021) which, as summarized by DEQ, found that the center timing (CT) of the Clackamas River's streamflow “is expected to shift 2 to 3 weeks earlier and *the 7-day low flow is expected to decrease* in most climate change and land use scenarios.”⁷³

Northwest is showing an increase in stream temperatures due to the impacts of climate change, in part, from anthropogenic sources.”)

⁶⁷ See e.g., *Id.* at 16 (summarizing findings from Butcher et al. (2016), who used the QUAL2Kw model to evaluate stream temperature response to future climate change in the South Fork Nooksack River and the mitigating effect of increased stream shading).

⁶⁸ See NMFS & ODFW, Upper Willamette River Conservation and Recovery Plan for Chinook Salmon and Steelhead at 5-21 (2011), https://www.dfw.state.or.us/fish/CRP/docs/upper_willamette/UWR%20FRN2%20Mainbody%20final.pdf.

⁶⁹ DEQ, *supra* n. 66.

⁷⁰ *Id.* at 7 (citing Isaak et al. (2018), Paul et al. (2019)).

⁷¹ *Id.* (citing Arismendi et al., (2013)).

⁷² *Id.* at 7-9.

⁷³ *Id.* at 8-9 (citing Chen & Chang (2021)).

Despite acknowledging scientific evidence demonstrating that streamflows will be lower in the future because of climate change, DEQ did not account for these changes in the draft TMDLs. For example, the draft TMDLs use 7Q10 streamflow levels that are based on historical data only, even though the scientific evidence that DEQ apparently reviewed shows that 7Q10 streamflow levels will be lower in the future because of climate change.⁷⁴ What's more, the draft TMDLs do not provide any mechanism for updating the draft TMDLs to reduce 7Q10 WLAs when 7Q10 streamflow levels decrease, as they are expected to, based on the scientific data. DEQ's authority to modify TMDLs is not a reliable safeguard, as DEQ has proved time and again that it must be sued to develop TMDLs in accordance with law, thereby instilling little to no confidence in the public that DEQ will update 7Q10 WLAs in the future.

By failing to account for decreasing streamflow, DEQ's assessment of loading capacity and underlying WLA and LAs is flawed. Due to these errors, neither the TMDL allocations nor the management strategies listed in the WQMP will attain or maintain water quality, as required by the TMDL rule. OAR 340-042-0030(15), (17). DEQ must revise the draft TMDLs to account for declining streamflows, otherwise the draft TMDLs will not attain and maintain water quality standards, as required by rule. OAR 340-042-0030(15).

B. DEQ Failed to Consider Climate Change Impacts on Pollutant Loading and Water Quality Parameters

The best available scientific data demonstrates that temperatures are rising in most streams, that warming air temperatures are increasing stream temperatures, and that both warming patterns will intensify. DEQ's literature analysis on climate change impacts acknowledges several studies that discuss these trends, although it fails to include other relevant studies.⁷⁵ While DEQ apparently accepts these scientific findings, DEQ fails to account for these changing conditions in its loading capacity or allocation analyses.⁷⁶ As a result, the analyses, assumptions, and allocations in the draft TMDLs are flawed and, therefore, the draft TMDLs will not attain or maintain water quality standards, as required by rule. OAR 340-042-0030(15).

In DEQ's incomplete climate change literature analysis, DEQ summarizes the findings of four studies on Oregon stream temperature trends, all of which found that temperatures in most streams have been rising for decades.⁷⁷ According to DEQ, the trends described in these studies "allow identification of a range of plausible historic climate change-driven stream temperature impacts across a variety of Oregon stream systems."⁷⁸ For example, DEQ identifies a study that found that the North Santiam River has an annual stream temperature increase trend of 0.16° C per decade and a June-August stream temperature increase trend of 0.52° C per decade.⁷⁹

⁷⁴ DEQ, *supra* n. 2 at 60-61 (describing data sources for calculating 7Q10 flows, none of which include modelled stream flow predictions for any of the Willamette River Subbasin waterbodies).

⁷⁵ See DEQ, *supra* n. 66 at 4-19.

⁷⁶ DEQ, *supra* n. 2 at 80-88.

⁷⁷ DEQ, *supra* n. 66 at 9-13.

⁷⁸ *Id.* at 9-10.

⁷⁹ *Id.* at 12 (citing Isaak et al. (2012)).

However, despite these trends – which will likely accelerate due to climate change – DEQ did not incorporate this relevant data in its analyses for the North Santiam Subbasin.⁸⁰

In the incomplete literature analysis on climate change effects, DEQ also summarizes three studies which found that air temperatures have been rising in the Pacific Northwest for decades.⁸¹ DEQ describes several modeling efforts which show that increasing air temperatures are causing stream temperatures to warm on the Columbia, Snake, John Day, South Fork Nooksack Rivers, Lookout Creek, and other waterbodies. DEQ notes that several of these studies determined that riparian shading would not be sufficient to offset stream temperature increases due to warming air temperatures, decreasing stream streamflow, or both factors.⁸²

Despite these examples of air temperature impacts on Pacific Northwest waterbodies, DEQ apparently believes that increasing air temperatures caused by climate change will have no impact on Willamette River subbasin rivers and streams. Indeed, DEQ does not even discuss the fact that increasing air temperatures in the Willamette Basin will warm Willamette Basin waterbodies in any section of the draft TMDLs other than the literature review. In other words, DEQ apparently read about climate change impacts but did nothing with the information other than summarizing it in an appendix to the draft TMDLs.

DEQ did not consider other studies that found that stream temperatures in the Pacific Northwest are projected to increase significantly in the foreseeable future, in part, due to increasing air temperatures. For example, DEQ’s literature analysis on climate change does not cite Beechie et al. (2012), even though it is one of the leading papers on climate change impacts to stream temperatures and salmon and steelhead in the Pacific Northwest.⁸³ Beechie et al. (2012) used models to predict streamflow and stream temperatures throughout the Pacific Northwest. The authors made the following finding related to the Willamette River system:

“Increased air temperatures will lead to increased water temperatures on both the west and east sides of the Cascade Mountains, and the scenario indicates a 1–4 C increase in stream temperatures (maximum weekly mean temperature) across the region by the 2030–2069 period and a 2–6 C increase by the 2070–2099 period (Figure 8). Highest mean weekly water temperatures vary significantly across the region in all periods, **with highest temperatures in reaches of the Snake and Willamette River basins (Figure 9)**. Because these areas are close to or exceed published thermal tolerances of most salmon species even during the historical period (1970–1999), they are most likely to shift to stressful or lethal thermal conditions in the future.”⁸⁴

⁸⁰ See e.g., DEQ, *supra* n. 2 at 87-88 (using observed 7DADM river temperatures for the North Santiam instead of 7DADM river temperatures that are more likely to occur due to climate change impacts).

⁸¹ DEQ, *supra* n. 66 at 4-7.

⁸² *Id.* at 16 (citing Butcher et al. (2016), Yonce et al. (2021), Fuller et al. (2022)).

⁸³ Beechie et al., *Restoring Salmon Habitat for a Changing Climate*, River Res. Applic. (2012) 29: 939-960 DOI: 10.1002/rra.2590.

⁸⁴ *Id.* at 8 (emphasis added).

As shown in Beechie et al. (2012), the Willamette River and its tributaries are expected to increase from <1° to as high 5° to 6° C, depending on the tributary.⁸⁵ The only other river basin that competes with this warming trend is the Snake River Basin, which, unlike the Willamette River, meanders through hundreds of miles of arid desert habitat.⁸⁶

DEQ also did not consider Wade et al (2013), which used modelled temperature and flow data to calculate water temperatures and flows for rivers throughout the Pacific Northwest.⁸⁷ The authors found that the greatest temperature increases would occur in the Upper Willamette, Lower Columbia, Upper Columbia, Lower Snake, and Far Upper Columbia River basins.⁸⁸ In the Willamette Basin, modelled increases in temperatures between the historical period (1970-1999) and 2030-2059 ranged from 1-4° C in the Willamette River and its tributaries.⁸⁹

Lastly, DEQ did not consider the Oregon Climate Change Research Institute's (OCCRI) recent climate change assessment, which predicts that the annual number of days in the Willamette Basin with an extreme heat index will double or triple compared to the period from 1991-2020.⁹⁰ As DEQ knows, more warm days means more warm water and, therefore, DEQ should have considered this information as well as other available data on future climate change effects (e.g., predicted changes in air temperature, streamflow, and water temperature).

Even though climate change is predicted to increase air and stream temperatures in the Willamette River Basin and its tributaries, DEQ only used steady-state air and streamflow temperatures based on historical data to develop the draft TMDLs. Indeed, DEQ made no efforts whatsoever to account for predicted increases in air and stream temperatures that are reasonably certain to occur and can be modelled. Because the draft TMDLs make no attempt to account for these predicted climate change impacts, neither the TMDL allocations nor the management strategies listed in the WQMP will achieve the draft TMDLs' purpose of attaining and maintaining water quality standards. OAR 340-042-0030(15).

C. DEQ Failed to Consider Climate Change Effects on Sensitive Beneficial Uses

DEQ did not consider climate change effects on four sensitive species that are beneficial uses and will be affected by the draft TMDLs. Specifically, DEQ ignored the existential risk that climate change poses to Lower Columbia River Chinook and steelhead and Upper Willamette River spring Chinook and steelhead, which are all listed as “threatened” species under the Endangered Species Act (“ESA”), 16 U.S.C 1531 *et seq.* 50 CFR § 223.102(e).

As explained by DEQ's sister agency, ODFW, climate change will increase stream temperatures and put these cold-water species at increased risk.⁹¹ ODFW and the National Marine Fisheries Service summarized some of these risks in the Upper Willamette River

⁸⁵ *Id.* at 11, Fig. 8.

⁸⁶ *Id.* at 12, Fig. 9.

⁸⁷ Alisa A. Wade et al., *Steelhead vulnerability to climate change in the Pacific Northwest*, Journal of Applied Ecology (2013).

⁸⁸ *Id.* at 5.

⁸⁹ *Id.*

⁹⁰ Oregon Climate Change Research Institute, Sixth Oregon Climate Assessment at 48 (2023).

⁹¹ See NMFS & ODFW, *supra* n. 68 at 5-22.

Conservation and Recovery Plan for Chinook and Steelhead (the “Recovery Plan”). For example, the Recovery Plan summarizes findings made by the OCCRI and the Climate Leadership Initiative for the Willamette Basin on future climate change effects.⁹² As summarized in the Recovery Plan, these findings showed a moderate decrease in historical summer flows, which are influenced by decreased snowpack, earlier snowmelt, and higher air temperatures.⁹³ Because of these changes, there may be lower base flows and longer low flow periods, which warm water temperatures. As a result, threatened Chinook salmon and steelhead could face more direct and indirect mortality and avoid habitat that has become too warm.⁹⁴ Additionally, modeling consistently showed annual average increases in temperature under all warming scenarios.⁹⁵

D. DEQ Did Not Account for Climate Change in its Models

DEQ did not incorporate predicted climate change impacts (e.g., increased air and water temperatures, decreased stream discharges) in its models, even though it is feasible to do so. As indicated in the TSD, DEQ only used historic and current data to develop a plan that is theoretically supposed to attain and maintain water quality in a future that will be hotter and drier than the past or present.⁹⁶ Apparently, DEQ did not adjust the modelling scenarios at all to account for any of the air and stream temperature changes discussed in the climate change literature analysis, Beechie et al. (2013), Wade et al. (2013), or OCCRI (2023). As a result, none of the allocations or assumptions based on DEQ’s modelling exercises account for loading caused by climate change and, therefore, the draft TMDL allocations are overbudgeted.

According to DEQ, “DEQ uses models to evaluate potential stream warming sources and, to the extent existing data allow, their current and TMDL allocation pollutant loads.”⁹⁷ As DEQ also explains in the TSD, DEQ used temperature and shade models to do the following:

“[C]omplete a source assessment and cumulative effects analysis, determine TMDL allocations and surrogate measures that attain the applicable temperature criteria, and develop information that will support TMDL implementation and development of the TMDL Water Quality Management Plan.”⁹⁸

Because these models did not incorporate predicted climate change effects, these assessments, analyses, and allocations are all inaccurate. As a result of these material errors, the draft TMDLs will not attain and maintain water quality, as required by rule. OAR 340-042-0030(15).

It is feasible to model future climate change impacts in a TMDL analysis. For example, the Washington Department of Ecology used a calibrated stream temperature model to estimate future climate change impacts on South Fork Nooksack River water temperatures with and without restoration of riparian forest vegetation. The analysis demonstrated the importance of restoration to buffer against climate change impacts:

⁹² *Id.*

⁹³ *Id.*

⁹⁴ *Id.*

⁹⁵ *Id.*

⁹⁶ DEQ, *supra* n. 2 at 56-60.

⁹⁷ *Id.* at 56.

⁹⁸ *Id.* at 60.

“The QUALK2w model simulations suggest that, without restoration of riparian shade, water temperatures during critical summer low-flow conditions could increase by amounts ranging from 3.5 to almost 6 °C by the 2080s. Restoration of full system potential riparian shading can help buffer against temperature increases and mitigate from 30 to 60 percent of the critical period increase; however, even with system potential shade, the critical condition maximum 7-day average stream water temperatures are projected to increase by 1.1 to 3.6 °C by the 2080s. In conjunction with this increase, the percent of stream miles in which critical condition water temperatures are potentially lethal to salmon is predicted by the model simulations to increase dramatically—from about 18 percent at present to a between 60 and 94 percent in the 2080s depending on the climate model analyzed.”⁹⁹

DEQ did not do a similar analysis for the Willamette River subbasins. Had DEQ performed a similar analysis, it would have likely determined that allocating new and increased WLAs (e.g., the proposed WLAs for the Three Basin Hatcheries) would not help in attaining or maintaining water quality. Indeed, allocating these WLAs will further decrease water quality.

E. DEQ Oversassigned the HUA and Overallocated Loading Capacity Because DEQ Did Not Account for Predicted Climate Change Effects

By failing to assign a portion of the HUA to climate change, DEQ overassigned the HUA and thereby overallocated loading capacity in violation of the HUA and TMDL Rules. OAR 340-041-0028(12)(b)(B), OAR 340-042-0040(4)(d). To comply with both rules, DEQ must revise the draft TMDLs by assigning portions of the HUA to climate change and making necessary reductions to other TMDL allocations to stay within the 0.3° C limit.

The HUA Rule requires that after a TMDL, “waste load and load allocations will restrict all NPDES point sources and nonpoint sources to a cumulative increase of no greater than 0.3 degrees Celsius (0.5 Fahrenheit) above the applicable criteria after complete mixing in the water body, and at the point of maximum impact.” OAR 340-041-0028(12)(b)(B). A load allocation is the “portion of a receiving water's loading capacity that is attributed either to one of its existing or future nonpoint sources of pollution or to natural background sources.” OAR 340-041-0002(30). Background sources include “all sources of pollution or pollutants not originating from human activities.” OAR 340-042-0030(1). For TMDLs, “background sources may also include anthropogenic sources of a pollutant that DEQ or another Oregon state agency does not have authority to regulate, such as pollutants emanating from another state, tribal lands or sources otherwise beyond the jurisdiction of the state.” *Id.*

⁹⁹ Butcher, J.B., M. Faizullahoy, H. Nicholas, P. Cada, and J.T. Kennedy. 2016. *Quantitative Assessment of Temperature Sensitivity of the South Fork Nooksack River Nooksack River under Future Climates using QUAL2Kw*. EPA/600/R-14/233. Western Ecology Division, National Health and Environmental Effects Research Laboratory, Corvallis, OR, at xvi.

DEQ admits that climate change is a background source that affects stream temperatures,¹⁰⁰ yet DEQ fails to assign any portion of the HUA to climate change.¹⁰¹ According to DEQ, “[s]tream temperature warming from climate change is a background source as the majority of the climate change causing pollutants emanate from outside Oregon.”¹⁰² Confoundingly, however, DEQ does not allocate any portion of the HUA to climate change.¹⁰³ Because the draft TMDLs distribute the entire HUA without assigning any portions of it to climate change, the draft TMDLs’ proverbial pollution budgets overspend loading capacity. As a result, the draft TMDLs will not pull the Willamette River subbasin out of water quality bankruptcy and will instead drive it further into default.

DEQ’s failure to assign a portion of the HUA to climate change seems hypocritical. DEQ recommended that EPA consider giving an allocation to climate change in the Columbia and Snake River temperature TMDL.¹⁰⁴ The EPA summarized DEQ’s recommendation as follows:

“EPA should consider giving an allocation to climate conditions as a source of heat affecting water temperatures. DEQ believes it is important for the TMDL to recognize the role of past and current climate conditions that influence the river temperature and to account for them in the allocations. There are many local and global actions being taken with the objective of reducing impacts from climate, and it is appropriate for the TMDL to reinforce the need for these actions through an allocation.”¹⁰⁵

Considering that the Willamette River and its subbasins are experiencing similar climate change impacts as the Columbia and Snake Rivers, it seems inconsistent for DEQ not to follow its own advice. Indeed, Beechie et al. (2012) projects that only the Snake River Basin rivals the Willamette River Basin in terms of projected stream temperature increases caused by rising air temperatures. Therefore, DEQ should follow its own advice by assigning a portion of the HUA to climate change and allocating a portion of the loading capacity to that background source.

F. DEQ Failed to Account for Climate Change in the Margin of Safety

DEQ failed to account for climate change in the draft TMDLs’ margin of safety, even though predicted climate change impacts eviscerate the accuracy of the draft TMDLs’ analyses, allocations, and assumptions. Because DEQ did not account for climate change in the margin of safety, the draft TMDLs do not comply with the TMDL rule. OAR 340-042-0040(4)(i).

A TMDL must include a margin of safety, which “accounts for uncertainty related to the TMDL and, where feasible, quantifies uncertainties associated with estimating pollutant loads, modeling water quality and monitoring water quality.” OAR 340-042-0040(4)(i). As DEQ explains in the draft TMDLs, “a margin of safety (MOS) takes into account the uncertainty in

¹⁰⁰ DEQ, *supra* n. 2 at 73.

¹⁰¹ DEQ, *supra* n. 7 at 35-39.

¹⁰² DEQ, *supra* n. 2 at 73.

¹⁰³ DEQ, *supra* n. 7 35-39.

¹⁰⁴ U.S. Env’tl Prot. Agency, Columbia and Lower Snake Rivers Temperature TMDL Response to Comments at 248 (2021) <https://www.epa.gov/system/files/documents/2021-08/tmdl-columbia-snake-temperature-rtc-08132021.pdf>.

¹⁰⁵ *Id.*

predicting how well pollutant reductions will result in meeting water quality standards.”¹⁰⁶ The margin of safety can be “expressed either explicitly, as a portion of the allocations, or implicitly, by incorporating conservative assumptions into the analyses.”¹⁰⁷

The draft TMDLs do not account for climate change in the margin of safety at all. Indeed, the draft TMDLs’ section on the margin of safety does not mention anything about climate change. If there is ever a more relevant section in the draft TMDLs to account for climate change, it is in the margin of safety, where critical uncertainties are addressed. However, the draft TMDLs are void of any explicit allocation or conservative assumptions regarding climate change. Because DEQ did not account for climate change in the margin of safety, the draft TMDLs will not attain and maintain water quality, as required by rule. OAR 340-042-0030(15).

DEQ should have included an explicit load allocation for climate change in the margin of safety because climate change will undeniably cause warming impacts and an explicit allocation would be transparent to the public. It is unreasonable for DEQ to believe that the draft TMDLs will achieve necessary pollutant reductions to meet water quality standards when the draft TMDLs do not even account for worsening climate change effects in their loading analyses. Climate change impacts on stream temperature will likely devour the HUA, yet the margin of safety includes no buffer at all for climate change impacts. To account for the uncertainty of the draft TMDLs’ assessment being accurate or effective in restoring water quality based on climate change effects, DEQ should include an explicit load allocation in the margin of safety to account for climate change. Putting a number on the margin of safety will demonstrate to the public that DEQ has accounted for it.

Apparently, DEQ did not make any conservative assumptions about climate change impacts and, therefore, DEQ did not implicitly account for climate change in the margin of safety. For example, it does not appear that DEQ made any conservative assumptions on whether climate change impacts will prevent WLAs from being protective of water quality standards.

Because DEQ did not adequately consider climate change in the margin of safety, it overallocated portions of the loading capacity to other sources and reserve capacity, thereby resulting in an overallocation of loading capacity. As a result, the draft TMDLs will not attain or maintain water quality, as required by rule. OAR 340-042-0030(15).

CONCLUSION

For the reasons stated in these comments, the draft TMDLs are unlawful and will not attain or maintain water quality standards, as required by rule. *Id.* DEQ must revise the draft TMDLs to comply with its own rules. Because of the urgency to restore water quality to protect threatened beneficial uses, including ESA-listed species, DEQ should immediately and fully correct the errors identified in these comments. These species do not have time to waste, and they need real plans for decreasing thermal pollution and restoring water quality now. The draft TMDLs are not those plans.

¹⁰⁶ DEQ, *supra* n. 2 at 1.

¹⁰⁷ *Id.*

Furthermore, if DEQ does not correct the draft TMDLs, Conservation Commenters will urge EPA to reject them.

Thank you for the opportunity to participate in this important process. We look forward to DEQ's response to these comments.

Sincerely,

/s/ Lindsey Hutchison

Lindsey Hutchison
Staff Attorney
Willamette Riverkeeper
403 SE Caruthers St.
Portland, OR 97214
(503) 223-6418
lindsey@willametteriverkeeper.org

/s/ Rob Kirschner

Rob Kirschner
Legal and Policy Director
The Conservation Angler
PO Box 13121
Portland, OR 97213
(503) 894-0439
rob@theconservationangler.org

/s/ Mary Stites

Mary Stites
Legal Fellow
Northwest Environmental Defense Center
Lewis & Clark Law School
10101 S. Terwilliger Boulevard
Portland, OR 97219
(503) 768-6673
mary@nedc.org

From: [Brian Posewitz](#)
To: [TEMPERATURETMDL Willamette * DEQ](#)
Subject: Comments of WaterWatch of Oregon on Draft Willamette Subbasins Temperature TMDL
Date: Friday, March 15, 2024 2:54:56 PM

You don't often get email from brian@waterwatch.org. [Learn why this is important](#)

Dear Oregon Department of Environmental Quality:

WaterWatch of Oregon (WaterWatch) is a nonprofit organization dedicated to protecting and restoring instream flows and the free-flowing character of Oregon's rivers and streams, and to wise management of Oregon's water resources in general.

Please consider the following comments of WaterWatch on the Draft Willamette Subbasins Temperature TMDL:

1. We appreciate the express recognition that water management activities and water withdrawals contribute to the failure of the designated water bodies to comply with water quality criteria. We also appreciate the specific load allocations recognizing the need to quantify the impacts of water management and water withdrawals and to limit or reduce the heat loads caused by those activities such that they do not impact water temperature beyond a specific amount that, in theory and assuming all other impacts are contained within their waste load and load allocations, will ensure attainment of water quality standards for temperature.
2. Given the express recognition of water management and water withdrawals as a nonpoint source of heat, the Oregon Water Resources Department (OWRD) should be a Designated Management Agency (DMA) required to prepare an implementation plan. OWRD has legal authority over water management and water withdrawals in the basin. OWRD can influence the water-temperature impact of water management and water withdrawals in many ways, including but not limited to: (a) by adequately conditioning (e.g., by requiring temperature mitigation) or not issuing permits for new water withdrawals and storage, and permits for existing but unpermitted withdrawals and storage, that will contribute to warming in the designated waterways; (b) by requiring better measurement and reporting of water withdrawals and water storage to ensure withdrawals and storage are within legal limits; (c) by enforcing laws against withdrawing water without a permit and/or withdrawing more water than legally allowed under a permit or water right; (d) by enforcing instream water rights to protect instream flows; (e) by ensuring forfeiture of unused water rights to prevent resumption of discontinued withdrawals at a future date; and (f) by require water conservation and management plans prepared by cities and irrigation districts to demonstrate stronger efforts to conserve water and reduce water withdrawals and possibly convert more

water rights to instream rights.

3. Management strategies for limiting the impact of water management and water withdrawals (including those at pages seven and 10 of the WQMP) are too limited and too general. The potential for water right transfers and leases is likely limited and insufficient to ensure attainment of the load allocations. Other measures suggested in Table 2 are also too limited and general. For example, the strategies do not suggest what should be done in “water right application reviews” or by whom (such as DEQ recommending denial without full temperature mitigation). The table also should include: (a) management strategies suggested in the preceding comment; (b) applications and/or support for additional instream water rights as appropriate; (c) conversion of unused hydroelectric water rights to instream water rights pursuant to ORS 543A.305; and (d) requiring full temperature mitigation for current and future water withdrawals (including permitted but undeveloped withdrawals) whenever possible, including on applications for extension of time to develop unused water use permits and on applications for permits and certifications associated with development and/or continuation of water withdrawals (e.g., removal-fill permits and water quality certification for water withdrawal and/or water-use infrastructure).
4. The draft TMDL documents do not seem to include an assessment of the extent to which current water withdrawals contribute to exceedances of water quality criteria relative to the proposed load allocations, or include any plan for determining in the future (by surrogate measure or otherwise) whether heat loads contributed by water management and withdrawals are within the load allocations or, if not, the extent to which they are not.
5. We appreciate the acknowledgement that ODA regulation is not achieving water quality objectives and that more needs to be done on private agricultural lands. (p. 21.)
6. Major water withdrawers and permit holders should also be responsible persons required to prepare implementation plans to show how withdrawals will be reduced or eliminated and how any temperature impacts from continuing withdrawals will be offset.
7. The TMDL documents give inadequate consideration to the cumulative impact of numerous small, in-channel reservoirs that add heat through increased thermal exposure of the water through pooling and expanded surface area. In addition to those listed at page 73 of Appendix E that are not required to monitor temperature impacts, OWRD routinely permits reservoirs under thresholds for dam safety (which can be unlimited in size if the dam is less than 10 feet high) with limited storage seasons that cannot practicably be enforced and with conditions that are not adequate to prevent the reservoirs from increasing stream temperatures. This further illustrates why OWRD should be a DMA under the TMDL.

8. The TMDL documents should include in the modeling and loading analysis and allocations the estimated future effects of climate change on stream flows, air temperatures and water temperatures.

Thank you for considering our comments.

Regards,

Brian Posewitz, Staff Attorney
WaterWatch of Oregon
213 SW Ash St.
Portland, OR 97204
(503) 432-8249
Email: brian@waterwatch.org



DEPARTMENT OF THE ARMY
U.S. ARMY CORPS OF ENGINEERS, PORTLAND DISTRICT
PO BOX 2946
PORTLAND, OR 97208-2946

15 March 2024

SUBJECT: U.S. Army Corps of Engineers comments on “DEQ Rulemaking – Willamette Subbasins Temperature TMDL Replacement”

Oregon Department of Environmental Quality
Attn: Michele Martin, Water Quality
700 NE Multnomah Street, Suite 600
Portland, Oregon 97232-4100
Willamette.TemperatureTMDL@DEQ.oregon.gov

Dear Ms. Martin,

The U.S. Army Corps of Engineers Portland District (Corps) reviewed the January 10, 2024 Oregon Department of Environmental Quality (DEQ) Rulemaking – Willamette Subbasins Temperature TMDL Replacement. Comments from the Corps are provided in this letter.

The Corps’ Willamette Valley System (WVS) consists of thirteen congressionally authorized multipurpose dams which provide flood risk management, hydropower, water quality, irrigation, navigation, recreation, water supply, and fish and wildlife benefits. The Corps operates and maintains this system of dams to meet all authorized purposes at each dam, with a primary operational focus of reducing flood risk levels for communities throughout the Willamette River Basin downstream to the City of Portland, Oregon. The dams capture runoff during flood season (typically November – January) to reduce the potential for downstream flooding, and then the captured water is released to provide flows that support ESA-listed fish habitat, hydropower generation, irrigation, municipal drinking water, pollution abatement, and other purposes throughout the year and especially during drier hydrologic periods (typically June – September).

The relationship between the WVS dams and water temperature is a function of multiple variables. The weather, volume of the reservoir, surface elevation and area of the reservoir, flow and temperature of inflowing rivers, and configuration of dam outlets all influence water temperature. The existence of some dams under some conditions results in warmer water temperatures than would otherwise occur, while conversely, the existence of the same dams under other conditions result in cooler water temperatures than would otherwise occur.

The WVS dams include two primary types of dams: storage and re-regulating projects. This basic distinction influences how a dam and its operation affect water temperature. Reservoir water held back by high-head storage dams often thermally stratify because they are designed to hold relatively larger volumes of water over longer periods of time (referred to as residence time) than re-regulating dams. Deeper reservoirs are less

impacted by the heat of the sun (i.e., short-wave solar radiation and long wave radiation from warmer air) and require more energy (such as from wind) to mix and de-stratify because of their depth. So, in deep reservoirs, incoming heat is absorbed at the surface, and the less dense warm water remains above the denser cooler, deeper water. By insulating water deeper in the reservoir, a dam can retain water that is cooler than inflowing water, particularly in the summer months. Many dams in the WVS are relatively deep storage reservoirs that retain cold water in the lower depths, which is most typically accessed via deep outlets. The average residence time of most WVS storage reservoirs is about 11 months, so cold winter water is stored and available during the summer. Typically, summer flow augmentation is provided by storage reservoirs to cool river temperatures downstream.

However, the construction and operation and maintenance (O&M) of WVS dams for all of their authorized purposes has contributed to the decline in anadromous Upper Willamette River spring Chinook salmon, Upper Willamette River winter steelhead, and bull trout. In 2008, the National Marine Fisheries Service (NMFS) and the U.S. Fish and Wildlife Service (USFWS) each released a Biological Opinion¹ (BiOp) on the effects of continued O&M of the WVS on species listed under the Endangered Species Act (ESA). The NMFS BiOp determined that the continued O&M of the WVS jeopardized the continued existence of certain listed species and provided a Reasonable and Prudent Alternative (RPA) with over 90 different measures that the Corps needed to accomplish to maintain compliance with the ESA in its O&M of the projects. The RPA included measures pertaining to fish passage and water quality, which could potentially be addressed in the long-term through structural solutions or by modifying operations. Many operational measures have been implemented since 2008 for improved downstream water temperature management. The Corps has published annual water quality reports² since 2009 that describe these actions in detail.

In 2018, environmental groups sued the Corps and NMFS alleging violations of the ESA associated with implementation of the 2008 BiOp. The U.S. District Court in Oregon issued an interim injunction in 2021 requiring the Corps to modify operations, in the continued absence of planned structural solutions, to focus on improved fish passage at the dams and downstream water quality management through alternative reservoir management (e.g., delayed refills, deep drawdowns, increased spill, etc.). The Corps was ordered to implement a combination of structural and operational modifications at some of the WVS dams and NMFS was ordered to issue a new BiOp by no later than December 31, 2024.

As you know as a cooperating agency, since 2018, USACE has been developing a Willamette Valley Programmatic Environmental Impact Statement (PEIS) in accordance with the National Environmental Policy Act (NEPA), with a goal of analyzing alternatives (including operations and other actions) that would allow the continued O&M of the WVS for all its authorized purposes, while also meeting ESA obligations. A proposed

¹ <https://www.fisheries.noaa.gov/resource/document/consultation-willamette-river-basin-flood-control-project>

² <https://usace.contentdm.oclc.org/digital/collection/p16021coll3/id/1154>

Preferred Alternative was described in the draft PEIS released to the public in November 2022³ and includes new actions that will result in major operational and structural modifications for additional downstream fish passage and water temperature management improvements. The Corps has appreciated the comments and coordination with DEQ during the WVS PEIS process.

The Corps has been providing five-year reports on Willamette Basin water quality monitoring to DEQ since 2009, as required in the NMFS Willamette BiOp. We have received minimal comments on these reports in recent years, with no indication that changes were needed. We look forward to continued collaboration as we work to understand the opportunities and constraints that exist in the system in relation to water temperature and compliance with both the Clean Water Act (CWA) and ESA. Currently, requirements under the CWA and ESA can conflict with one another at times, so coordination and compatibility of these criteria and targets in the Willamette Basin could lead to more attainable regulations. The Corps recognizes DEQ's early efforts and time to share the approach and methodology DEQ has used in developing the TMDL. However, the Corps has major concerns and comments that focus on the rules and methods proposed in the TMDL. Comments contained in this letter pertain to the following documents provided by DEQ⁴:

- Draft Willamette Subbasins Total Maximum Daily Loads for Temperature (TMDL)
- Draft Willamette Subbasins TMDL Technical Support Document (TMDL TSD)
- Draft Willamette Subbasins Water Quality Management Plan (WQMP)

The Corps is submitting the following technical and editorial comments that are grouped by topic and document. These technical and editorial comments are intended to provide clarity to the TMDL, TMDL TSP, WQMP, and appendices. The Corps' comments are organized as follows:

SECTION A – Major Comments

SECTION B – Minor comments that apply to the TMDL

SECTION C – Minor comments that apply to the TMDL TSP

SECTION D – Minor comments that apply to the WQMP

SECTION A – Major Comments

Comment 1

The Corps applied for NPDES permits for the WVS hydropower dams in September 2019, and according to Oregon DEQ's Statewide Permit Issuance Plan for Federal Fiscal Years 2024-2028 these permits planned year of issuance is 2025. The draft TMDL does not include waste-load allocations. These permits should be developed in tandem with the TMDL and should not impair the Corps' ability to effectively operate and maintain the dams for the multiple congressionally authorized purposes. It would

³ <https://www.nwp.usace.army.mil/Locations/Willamette-Valley/System-Evaluation-EIS/>

⁴ Accessed 1/11/2024 at <https://www.oregon.gov/deq/rulemaking/pages/willamettetemptmdl.aspx>

benefit DEQ and the Corps if a consistent methodology and rule set is defined between Temperature TMDL requirements in the Willamette and Columbia rivers.

Comment 2

ODEQ TMDL rule, 340-42-0040(6) considers the distribution of load allocations. The draft TMDL does not use any of these considerations when assigning a zero heat load allocation to dams. Please consider: (a) Contributions from sources; (b) Costs of implementing measures; (c) Ease of implementation; (d) Timelines for attainment of water quality standards; (e) Environmental impacts of allocations; (f) Unintended consequences; (g) Reasonable assurances of implementation and (h) Any other relevant factor.

Comment 3

ODEQ TMDL rule 340-42-0040(4)(I) provides the framework for the Water Quality Management Plan (WQMP) to be included in the TMDL. The WQMP included in the draft TMDL does not include elements listed in the rule, especially related to the Corps' implementation plan.

Comment 4

The Corps has major concerns with the surrogate measures for dam owners defined in Section 9.3.1 of the TMDL TSD:

- a) Reservoirs should be allocated a portion of the Human Use Allowance because they have been identified as a source contributing to temperature impairment. Reservoirs are the only nonpoint source category which is required to monitor instream temperature and quantify their impact. For comparison, consumptive use and existing infrastructure (not dams/reservoirs) received 0.02 deg C and 0.05 deg C, respectively, but have few obligations. The statement in Section 9.3.1 of the TMDL TSP that "Dam and reservoir operations have been allocated 0.00°C of the human use allowance" does not account for the human uses in which the Corps reservoirs were built to support. Please explain the methodology for allocating the human use allowance. A non-zero human use allowance should be allocated for Corps dam and reservoir projects, as the dams were authorized by Congress in federal law and constructed for multiple uses, some of which are human uses (e.g., flood risk management, hydropower, recreation, fish and wildlife) in each Willamette tributary reach where dams exist.
- b) Upstream influences of warming caused by forestry practices and wildfire may have an influence on upstream water temperature in each sub-basin. How have these factors been incorporated into the implementation of the temperature TMDL?
- c) The phrase "With DEQ approval..." in Section 9.3.1(a) of the TMDL TSD does not establish a definitive goal to achieve. This is problematic in the context of a regulatory document, adding vulnerability and uncertainty dependent on the interpretation of different agency staff that may change at any moment.

Additionally, the current WQMP does not provide sufficient detail regarding implementation plan requirements. The Corps requests that DEQ provide more definitive verbiage so that Designated Management Agencies (DMAs) like the Corps can submit an approvable water quality implementation plan.

- d) It is not clear where a cumulative effects analysis is needed or who will be performing this task. Section 9.3.1 of the TMDL TSD discusses DEQ approval of a cumulative effects analysis but does not discuss who would be performing this action. Section 5.3.5.1 of the WQMP discusses this as an option for dam owners, while Table 7 in the WQMP suggests that this analysis is required to be submitted following a QAPP and temperature assessment submittal. If this is a requirement of dam owners, please provide a definition of the term "cumulative effects" and an example of a "cumulative effects analysis" as it pertains to nonpoint sources and reservoir operations. Also, it is unclear whether cumulative effects allow for temporal effects in any given year. Dam releases often provide a beneficial cooling effect during spring spawning periods that should be accounted for as a benefit in the annual thermograph downstream of Corps dams. Please clarify whether cumulative annual heat loadings (above/below the surrogate without dams temperatures) can be used to assess compliance. Please also provide a definition of "cooler ambient temperatures".
- e) Section 9.3.1(b) of the TMDL TSD contains double-negative statements, unnecessarily long sentences, and is difficult to understand by our staff scientists, engineers, and the public. Please re-write this paragraph in plain language and provide an example of how and where the criteria would be applied.

Comment 5

The Corps is concerned that the temperature criteria (Section 5.3.5.1 of the WQMP) and temperature target surrogate measures (TMDL Rule Section 9.1.4.1 and TMDL Section 9.3) are not coordinated with temperature targets established by NMFS and included in the Willamette BiOp for ESA-listed anadromous species (winter steelhead and Chinook salmon). NMFS is currently drafting a new BiOp for the WVS, which will likely address water temperature targets in the Willamette Basin. A comparison of temperature targets is provided in Appendix D of the WVS PEIS and provides context for this comment as seen in Figure 1. DEQ has provided comment on the WVS PEIS indicating that temperature targets provided by Resource Agencies (i.e., NMFS) "...might substitute for those provided by the 2006 TMDL". Temperature targets applied to modeling work within the WVS PEIS were based on pre-dam water temperature measurements and previous studies of thermal conditions upstream of USACE Willamette reservoirs⁵. Such research has shown that in order to target a "natural" seasonal water temperature pattern downstream, warm water needs to be released from near the top of the reservoir during spring and summer. This will reduce the

⁵ Buccola, N.L., Stonewall, A.J., and Rounds, S.A., 2015, Simulations of a hypothetical temperature control structure at Detroit Dam on the North Santiam River, northwestern Oregon: U.S. Geological Survey Open File Report 2015 1012, 30 p., available at <https://doi.org/10.3133/ofr20151012>

accumulated heat in the epilimnion in summer, thereby reducing release temperatures in autumn when the lake level and thermocline are dropping in elevation to meet the lower outlets. The likelihood of making real improvements to water temperature will improve if criteria and target development is coordinated and relevant for DEQ, NMFS, and the Corps.

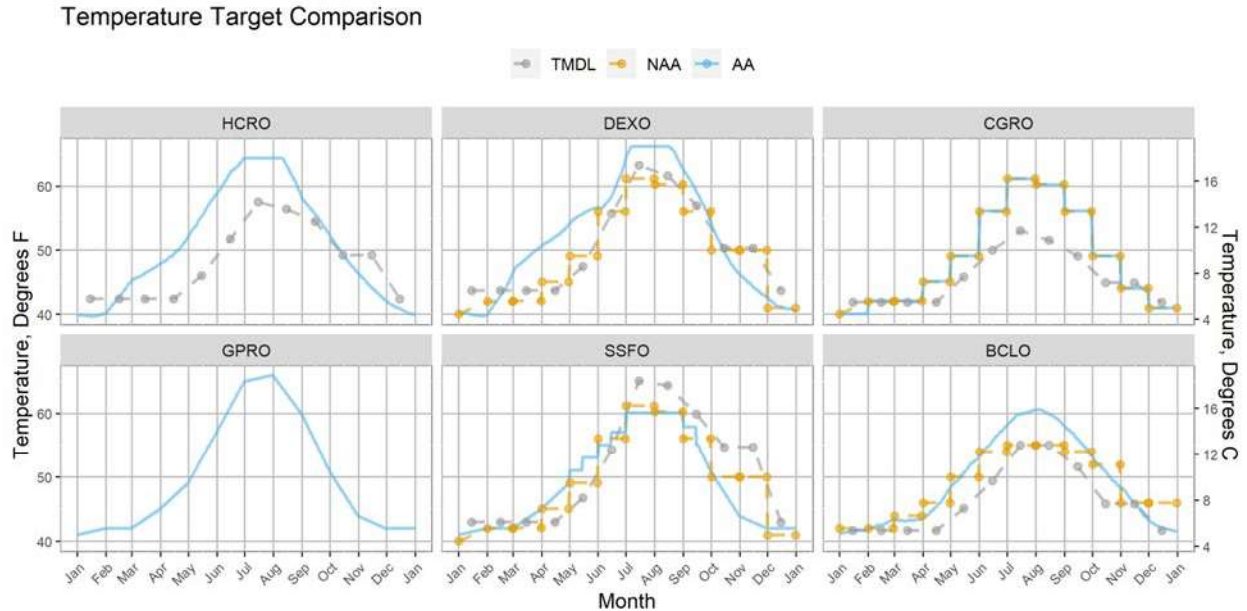

Figure 1. Temperature targets used at each CE-QUAL-W2 reservoir temperature model within the WVS PEIS for all alternatives except No Action (labeled "AA") compared to maximum temperature targets defined by NMFS 2008 Willamette BiOp (used operationally by USACE from 2017 to 2022; labeled "NAA") and the Oregon Department of Environmental Quality (DEQ) Total Maximum Daily Load (TMDL) Monthly Median Target Temperatures (labeled "TMDL"). Sites are defined as below the following dams: Detroit-Big Cliff: BCLO, Green Peter: GPRO, Foster: SSFO, Cougar: CGRO, Hills Creek: HCRO, Lookout Point-Dexter: DEXO. Note: HCRO and GPRO sites did not have NAA operational temperature targets defined.

Comment 6

In describing the nonpoint source contributions from the operation of dams and reservoirs, the temperature water quality criteria are overly simplified and not consistent with measures to improve conditions for ESA-listed fish. Specifically, the statement "Management and operation of dams and reservoirs to minimize temperature warming" (TMDL TSP Section 7.2, 3rd paragraph, 2nd bullet) does not account for seasonally appropriate dam releases intended to improve habitat for ESA-listed fish under the existing NMFS BiOp or what basis is used for defining warming. For example, the water temperature control tower at Cougar Dam and operational temperature management at Detroit Dam release warm lake-surface water during the warm season to minimize temperature exceedances in the fall.

Comment 7

Temperature monitoring described in Section 5.3.5.1 of the WQMP should not apply to all reservoirs equally. Temperature management at most Corps Willamette reservoirs is limited by the depth of each outlet (dam configuration), the dam safety rules associated with each outlet, authorized purposes (operations required to meet flood risk

management, hydropower generation, irrigation, water supply, fish and wildlife, water quality, recreation), and other legal obligations. Some reservoirs do not regularly exhibit stratification (Fern Ridge Lake), and/or have operations (i.e., re-regulating reservoirs: Big Cliff, Dexter) or outlets (Dorena, Cottage Grove, Blue River, Hills Creek – dams that only have deep regulating outlets that can safely be used in a controlled manner during summer) that limit the potential to manage temperature through operational methods. The Corps has prioritized investment in temperature monitoring at sites where temperature management is possible (Detroit, Green Peter, Foster, Lookout Point). The Corps currently has over 150 continuous monitors through the Willamette Basin USGS Cooperative Stream Gaging Program through an annual contractual funded agreement exceeding \$1.1M in 2023⁶. Since 2004, the Corps has invested in developing CE-QUAL-W2 hydrodynamic temperature models and studying the potential temperature management opportunities of each reservoir. In the implementation plan, the Corps will continue to evaluate appropriate monitoring and analysis based on past data and studies.

Comment 8

Effective shade surrogate measure targets to meet nonpoint source load allocations should not be applied to reservoir operations, and therefore Corps reservoir areas should be removed from Section 9.3.2 and Table 9-6 of the TSD. Trees cannot be planted on or near the dams due to dam safety concerns or below typical high reservoir elevations as trees will not survive inundation. Furthermore, based on the interactive shade map provided by DEQ (WilTempMap.html), the Corps reservoirs that had non-zero shade gaps should be clipped to not include the water body are as follows:

- OR_LK_1709000203_02_100706; Cottage Grove Lake
- OR_LK_1709000202_02_100705; Dorena Lake
- OR_LK_1709000404_02_100758; Blue River Lake
- OR_LK_1709000109_02_100701; Fall Creek Lake
- OR_LK_1709000301_02_100708; Fern Ridge Lake
- OR_LK_1709000603_02_100771; Green Peter Lake
- OR_LK_1709000503_02_100770; Big Cliff Reservoir

Please consider clipping (removing) shade gap from these reservoirs and re-calculating the total for the Corps in Table 9-6 in the TMDL TSD, which would effectively be zero.

SECTION B – Minor Comments that apply to the TMDL

Comment 1

Chap 2, 3rd paragraph, last sentence: "Waters excluded from the Willamette Subbasins TMDLs (Table 2-2) include the Willamette River, Multnomah Channel, and tributaries to the Willamette River downstream of the following dams: River Mill Dam, Detroit Dam, Foster Dam, Fern Ridge Dam, Dexter Dam, Fall Creek Dam, and Cottage Grove Dam." Please provide reasoning and logic as to why each tributary is included or excluded

⁶ Published annually in Appendix A of the USACE Willamette Basin Annual Water Quality Report <https://usace.contentdm.oclc.org/digital/collection/p16021coll3/id/1154>

from the TMDL. For example, why not also exclude Dorena, Blue River, Cougar, Green Peter, Lookout Point, or Hills Creek Dams in the Subbasin TMDL?

Comment 2

Table 8-2: Please include a URL in the PDF document to a GIS version of Table 8-2 so that the reach of interest can be verified.

SECTION C – Minor Comments that apply to the TMDL TSP

Comment 1

Figure 2-2: Please define what the difference is between GNIS streams and others.

Comment 2

Figure 4-2: Legend for Salmon and Steelhead Spawning Use Designations has the same colored line associated with different dates and is therefore not clear which reaches apply to which dates. Please clarify or provide a table with Salmon and Steelhead Spawning Use Designations and numeric criteria for each reach on the map.

SECTION D – Comments that apply to the WQMP

Fig 3: Please include “yes” and “no” text for each branch of the decision tree.

The Corps is committed to environmental compliance and protection of the nation’s waters. The Corps also recognizes and acknowledges DEQ’s role as defined by the Clean Water Act and appreciates the opportunity to comment on these rules to improve water temperature conditions in the Willamette Basin.

The point of contact for additional information is Kathryn Tackley, Water Quality Lead, in the Reservoir Regulation and Water Quality Section at Kathryn.L.Tackley@usace.army.mil or (503) 808-4883.

Sincerely,

HART.SALINA.N.1
278851768



Digitally signed by
HART.SALINA.N.1278851768
Date: 2024.03.15 07:59:43 -07'00'

Salina N. Hart
Chief Reservoir Regulation & Water Quality Section
Portland District
U.S. Army Corps of Engineers



CLACKAMAS

**WATER
ENVIRONMENT
SERVICES**

GREGORY L. GEIST | DIRECTOR

Water Quality Protection
Surface Water Management
Wastewater Collection & Treatment

February 20, 2024

Michele Martin
DEQ Water Quality Division
700 NE Multnomah Street, Suite 600
Portland, Oregon 97232-4100

Sent via email to: Willamette.TemperatureTMDL@DEQ.oregon.gov and
Sandy.SubbasinTMDL@DEQ.oregon.gov

Subject: Comments on the Draft Willamette and Sandy River Watershed Temperature TMDLs

Dear Michele Martin,

Thank you for the opportunity to provide comments about the January 2024 draft temperature TMDLs for the Willamette and Sandy River watersheds.

Clackamas Water Environment Services (WES) produces clean water, protects water quality and recovers renewable resources. We do this by providing wastewater services, stormwater management, and environmental education. It's our job to protect public health and support the vitality of our communities, natural environment, and economy. We do that as a collaborative partner in building a resilient clean water future where all people benefit and rivers thrive.

WES maintains and operates:

- The Boring Sewage Treatment Plant (STP), which discharges into the North Fork of Deep Creek in the Willamette River watershed in Boring.
- The Hoodland STP, which discharges into the Sandy River in Welches.
- The public storm sewer system in portions of northwest Clackamas County in partnership with Clackamas County and the Cities of Happy Valley and Rivergrove.

WES has reviewed these two draft TMDLs and has the following comments:

Boring STP:

The January 2024 draft Willamette River TMDL includes a wasteload allocation (WLA) of 0.125 million kcal/day for the Boring STP. This draft allocation is substantially lower than the current NPDES permit limits which are based on the 2006 Willamette River TMDL. The current 2016-2021 NPDES permit for the Boring STP specifies wasteload allocations of 0.333 million kcal/day from June 16th to October 14th based on the core cold water criteria (16 C), and 0.357 million kcal/day from October 15th to June 15th based on fish spawning use (13 C). **An assessment of recent thermal loads in the STP's effluent shows that the facility would be in immediate non-compliance with the proposed WLA in the Jan. 2024 draft TMDL.** Please see the

attached Excel file with Excess Thermal Load data from the Boring STP from April 2020 through October 2023. In many instances, the 7-day average excess thermal load (ETL) discharged during this recent time period exceeds the 0.125 million kcal/day which was allocated to the Boring STP in the Jan. 2024 draft TMDL. Because this is a wastewater treatment plant which serves a community, WES does not have any available options for reducing the temperature or volume of the Boring STP's effluent. Because there is a significant amount (0.155 C) of reserve capacity available in this section of the North Fork of Deep Creek (see Table 9-10), we urge DEQ to distribute some of this reserve capacity to the Boring STP's WLA to provide an achievable WLA for the Boring STP.

In the Jan. 2024 draft Willamette TMDL's Water Quality Management Plan, it says this about WLAs for point sources: *"The allocation was increased above 0.075 when analysis indicated that 0.075 would result in immediate noncompliance. DEQ only increased the allocation if there was sufficient loading capacity available. An assessment of current thermal loading was not possible for all point sources due to project time constraints or lack of data."* It appears that DEQ hasn't yet conducted this assessment of thermal loading for the Boring STP and we urge DEQ to do this prior to finalizing the TMDL.

Also prior to finalizing the TMDL, we also encourage DEQ to establish two WLAs for the Boring STP, as was done in the 2006 Willamette TMDL. One WLA would be for the period from June 16th to October 14th and the other would be from October 15th to June 15th.

Finally, the Jan. 2024 draft Willamette TMDL says the North Fork of Deep Creek's 7Q10 flow at the Boring STP is 0.65 CFS, but WES' 2009 mixing zone study for the Boring STP says the 7Q10 flow there is 0.24 CFS, and this is the 7Q10 flow which DEQ relied upon to write portions of the Boring STP's current (2016-2021) NPDES Permit. Please evaluate this situation to be sure that DEQ is using the most appropriate 7Q10 flow in the new TMDL.

Hoodland STP:

The January 2024 draft Sandy River TMDL includes a wasteload allocation (WLA) of 23.4 million kcal/day for the Hoodland STP. This draft allocation is substantially lower than the current NPDES permit limits which are based on the 2005 Sandy River TMDL. The current 2022-2027 NPDES permit for the Hoodland STP specifies a WLA of 29.9 million kcal/day, which raises the question of why is the Hoodland STP's WLA proposed to be reduced by 6.5 million kcal/day? Is this portion of the Hoodland STP's load proposed to be given to the City of Sandy's proposed new wastewater treatment plant discharge into the Sandy River?

Please see the attached Excel file with Excess Thermal Load data from the Hoodland STP from May 2020 through October 2023. Within this set of data, the highest 7-day average ETL discharged was 7.2 million kcal/day, so a 23.4 million kcal/day allocation to the Hoodland STP in the new TMDL should be satisfactory, because it will allow for some increase in its ETL over time (due to population growth, for example) without causing noncompliance.

And finally, we're concerned about Table 9-3, which contains the Human Use Allowance for the section of the Sandy River where the Hoodland STP is located. "Warming from tributaries" is proposed to receive 0.21 C of the 0.3 C Human Use Allowance and there isn't any allocation for

Reserve Capacity. Please explain why Reserve Capacity receives no allocation. If DEQ is able to do so, we recommend that some of the very large allocation for “warming from tributaries” be re-distributed to Reserve Capacity to ensure that additional loading is available for distribution to sources in the future – potentially including the Hoodland STP if needed – in this reach of the river.

Oregon’s Water Resources Department:

Oregon’s Water Resources Department should be identified as a DMA (Designated Management Agency) in the Sandy River and Willamette River Watershed Temperature TMDLs. In Appendix A on Page #54 of #83 in the Jan. 2024 draft Willamette River TMDL’s Water Quality Management Plan, in rows #126 to #133 in the table, Oregon’s Dept. of Forestry (ODF), Oregon’s Department of Agriculture (ODA), and several other state agencies are identified as DMAs. Why was WRD omitted from this draft list?

On page #7 of #83 in the Jan. 2024 draft Willamette River TMDL’s Water Quality Management Plan, water rights and the benefit of enhancing instream flows are addressed: *“Water conservation is a best management practice that directly links the relationship between water quantity and water quality. Leaving water instream functions as a method to protect water quality from flow-related parameters of concern, such as temperature. Under state law, the first person to file for and obtain a water right on a stream is the last person to be denied water in times of low stream flows. Therefore, restoration of stream flows may require establishing instream water rights. One way this can be accomplished is by donating or purchasing out-of-stream rights and converting these rights to instream uses.”* To support attainment of the allocations in these water temperature TMDLs, the WRD could communicate with senior water rights holders, for example, to verify that they aren’t taking more water for consumptive purposes (ie. irrigating crops) than is allowed by their water right in order to maintain higher instream flows and lower instream temperatures.

Clackamas WES is a DMA:

On Page #54 of #83 in the Jan. 2024 draft Willamette River TMDL’s Water Quality Management Plan, in row #125 in the table found in Appendix A, WES’ name isn’t spelled correctly. It says *“Water and Environment Services”*. The correct name to use here is Water Environment Services.

MS4 Permits in the Jan. 2024 draft Willamette River TMDL:

- Please re-name Table 9-11, which begins on page #40. Its current title is “Point Sources” but MS4 Permits, which are point sources, have been excluded. MS4 Permits were included in Table 7-2.
- Section 9.1.2 says *“The wasteload allocation for registrants under the general stormwater permits (MS4, 1200-A, 1200-C and 1200-Z) and general permit registrants not identified in Table 9-11 is equal to any existing thermal load authorized under the current permit.”* This is problematic because we’re unsure what the existing thermal load is that was authorized by the Phase II General MS4 Permit, and a NPDES permit cannot authorize a MS4 to discharge an excess thermal load if the load isn’t first properly authorized by the temperature TMDL. Note that this phrase says only “general” MS4 permits are included. Please remember to also consider Phase I individual MS4 Permits

when addressing this subject (Clackamas WES' Phase I MS4 Permit is an individual MS4 permit).

- On page #23, the draft TMDL says *“Based on a review of published literature and other studies related to stormwater runoff and stream temperature in Oregon (see TSD section 7.1.2), DEQ found there is not sufficient evidence to demonstrate that stormwater discharges authorized under the current municipal (MS4s) permits or the construction (1200-C) and industrial (1200-A and 1200-Z) general stormwater permits contribute to exceedances of the temperature standard.”* The TMDL also says *“Waste load allocations were not assigned to storm water sources such as municipal separate storm sewer systems (MS4s) and combined sewer overflows because they have been determined not to be significant contributors to heat over a seven day period as specified in the temperature standard.”* We encourage DEQ to provide a modest temperature WLA to all MS4s in this TMDL – and also in the Sandy River TMDL – to avoid unintended compliance problems if it turns out that one or more MS4s are someday found to be a significant contributor of heat. An example could be a storm sewer system with a large stormwater treatment & detention pond near the outfall with a constant source of spring-fed flow (24-7) during the hot Summer months. In this instance, this spring water could be warmed somewhat on its way through the pond before being discharged into the creek, wetland or river.

Please do not hesitate to call me at (503) 742-4581 if you have any questions, concerns or comments.

Sincerely,



Ronald Wierenga
Deputy Director

cc Andrew Swanson (WES)







Final_WES_comment_letter_for_Jan_2024_draft _Sandy_and_Will_TMDLs

Final Audit Report

2024-02-20

Created:	2024-02-20
By:	Jeffrey Miller (JMiller@clackamas.us)
Status:	Signed
Transaction ID:	CBJCHBCAABAAGmycshZEwMbmPJCEOn1Ape2e7YdNWgCX

"Final_WES_comment_letter_for_Jan_2024_draft_Sandy_and_Will_TMDLs" History

-  Document created by Jeffrey Miller (JMiller@clackamas.us)
2024-02-20 - 9:12:47 PM GMT
-  Document emailed to rwierenga@clackamas.us for signature
2024-02-20 - 9:13:05 PM GMT
-  Email viewed by rwierenga@clackamas.us
2024-02-20 - 9:15:39 PM GMT
-  Signer rwierenga@clackamas.us entered name at signing as Ronald Wierenga
2024-02-20 - 11:15:45 PM GMT
-  Document e-signed by Ronald Wierenga (rwierenga@clackamas.us)
Signature Date: 2024-02-20 - 11:15:47 PM GMT - Time Source: server
-  Agreement completed.
2024-02-20 - 11:15:47 PM GMT