

MKP Digester System Process Flow Diagram

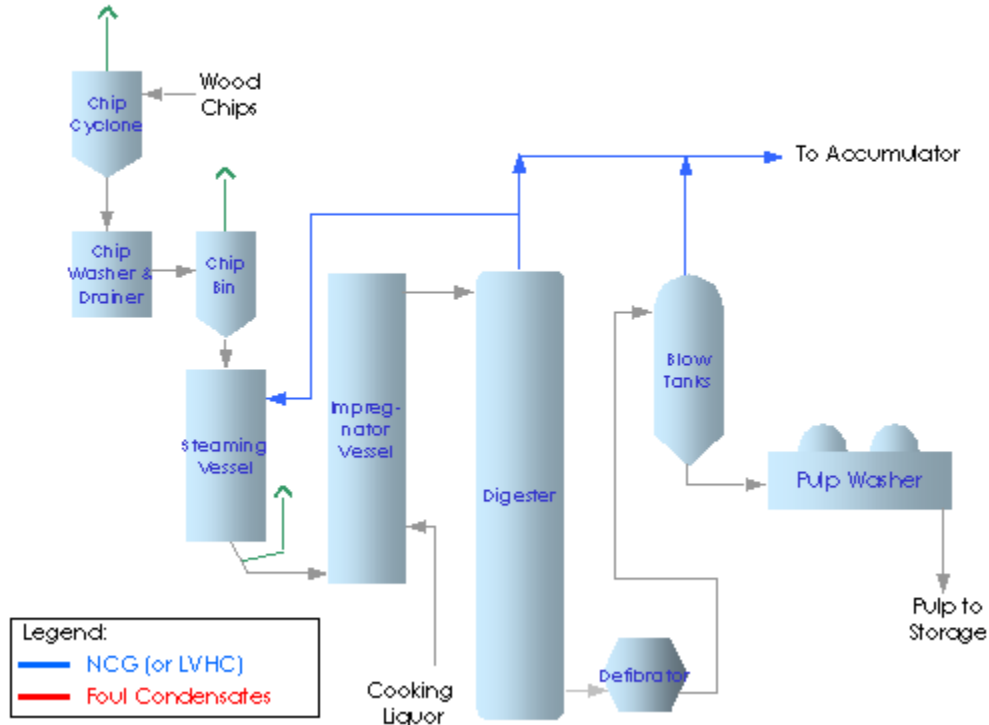

Batch Digester System Process Flow Diagram

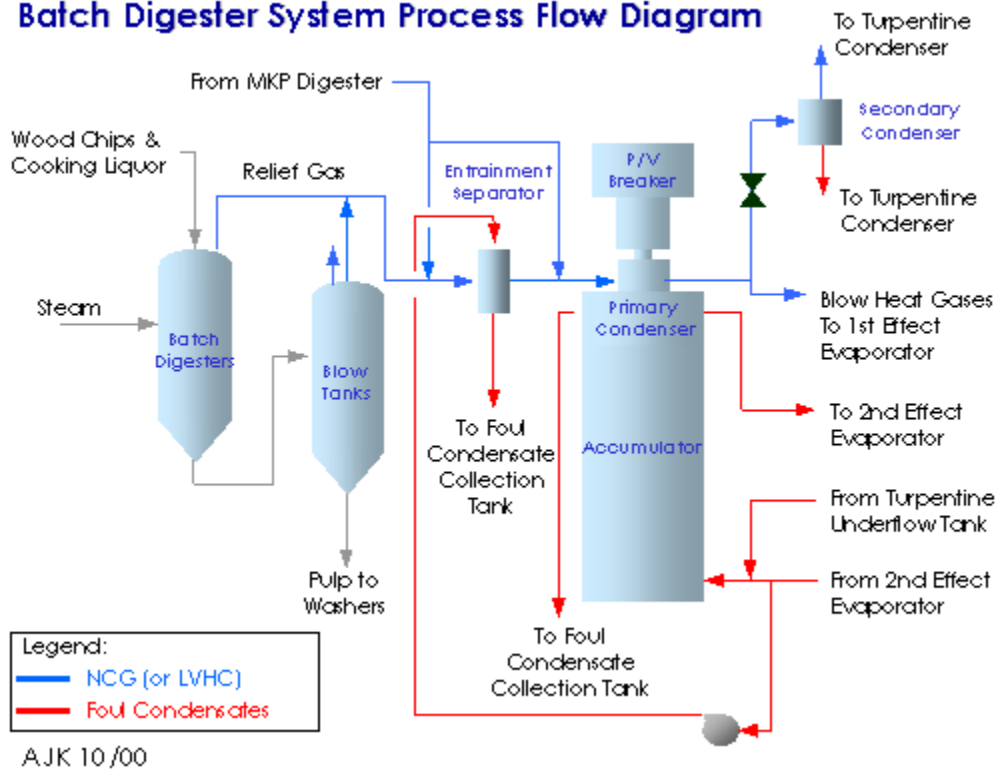

Turpentine Recovery System Process Flow Diagram

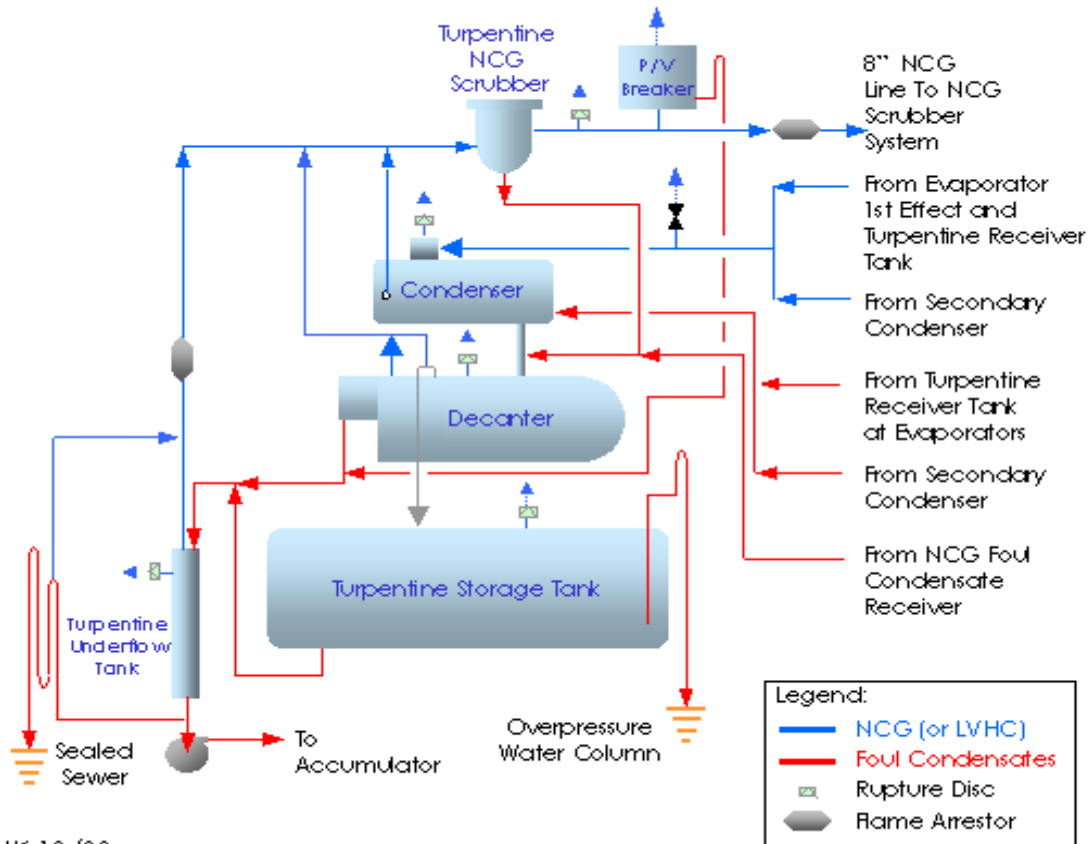

AJK 10/00

Evaporator System Process Flow Diagram

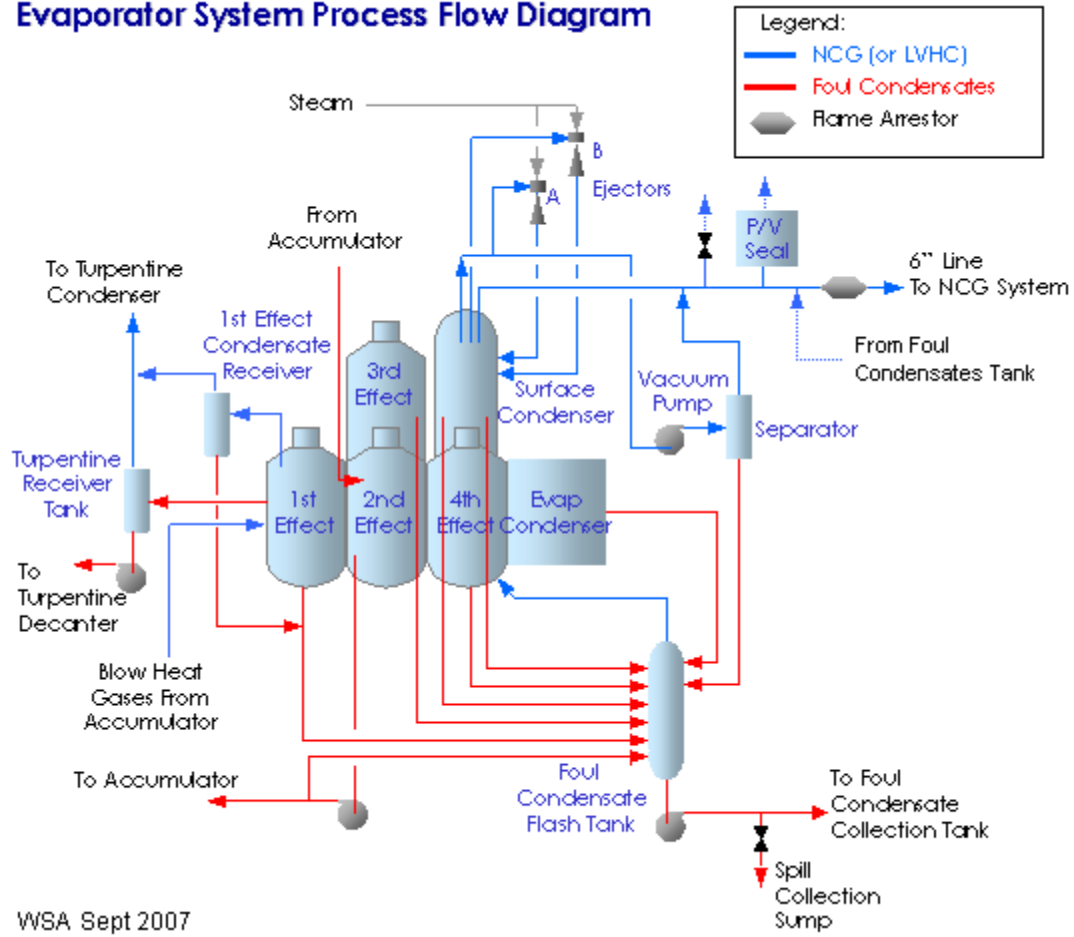

WSA Sept 2007

Lime Kiln System Process Flow Diagram

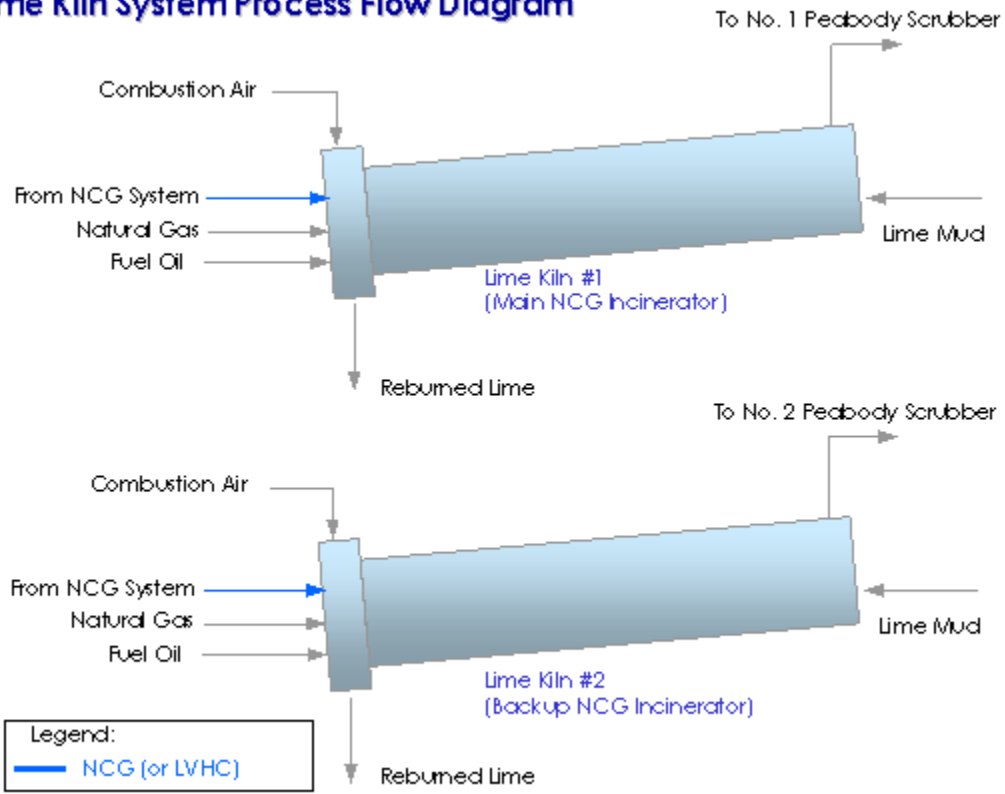

AJK 9/00

NCG System Process Flow Diagram

Legend:

- NCG (or LVHC)
- Foul Condensates
- Rupture Disc
- Flame Arrestor

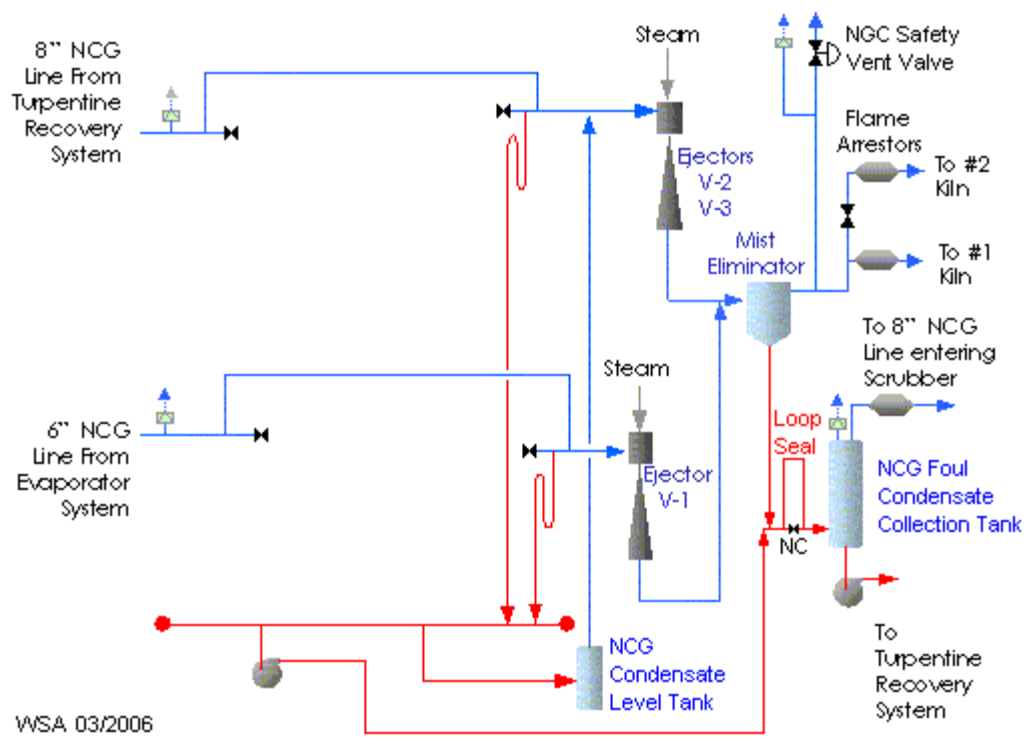

WSA 03/2006

Diagram revisions trigger a Management of Change in Chemical Process Safety

Foul Condensate Collection System Process Flow Diagram

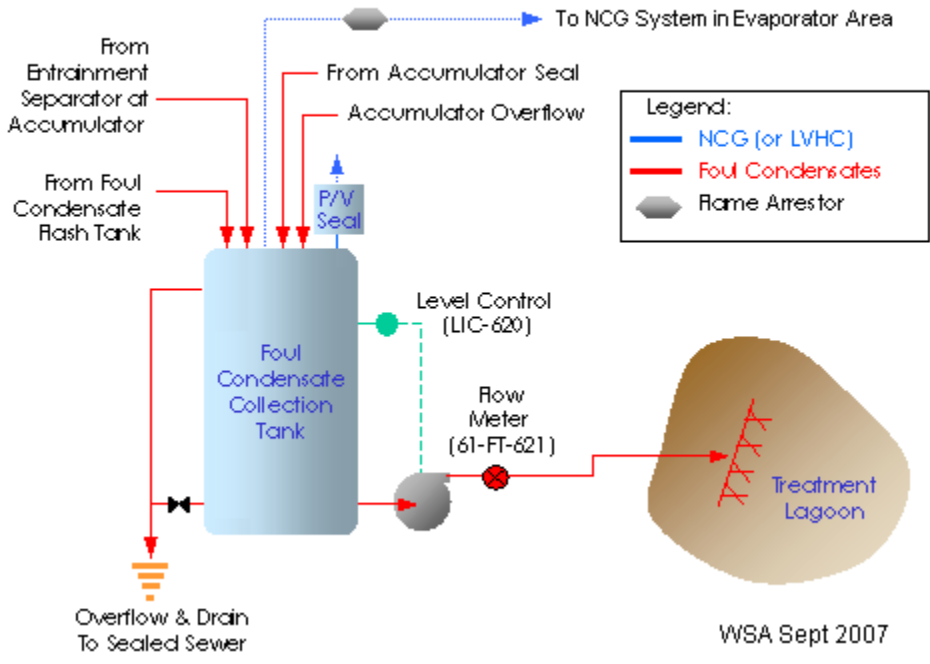

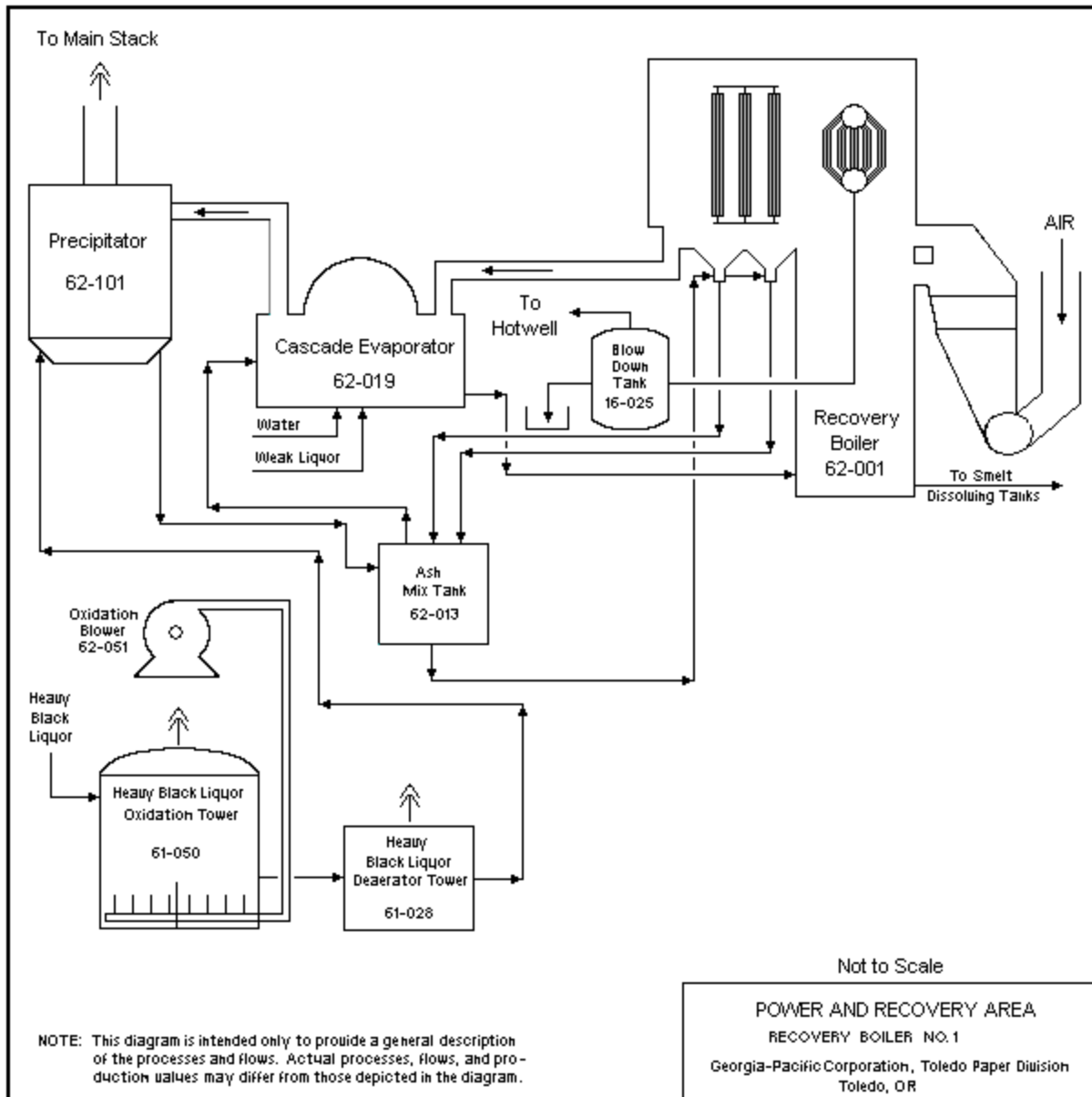

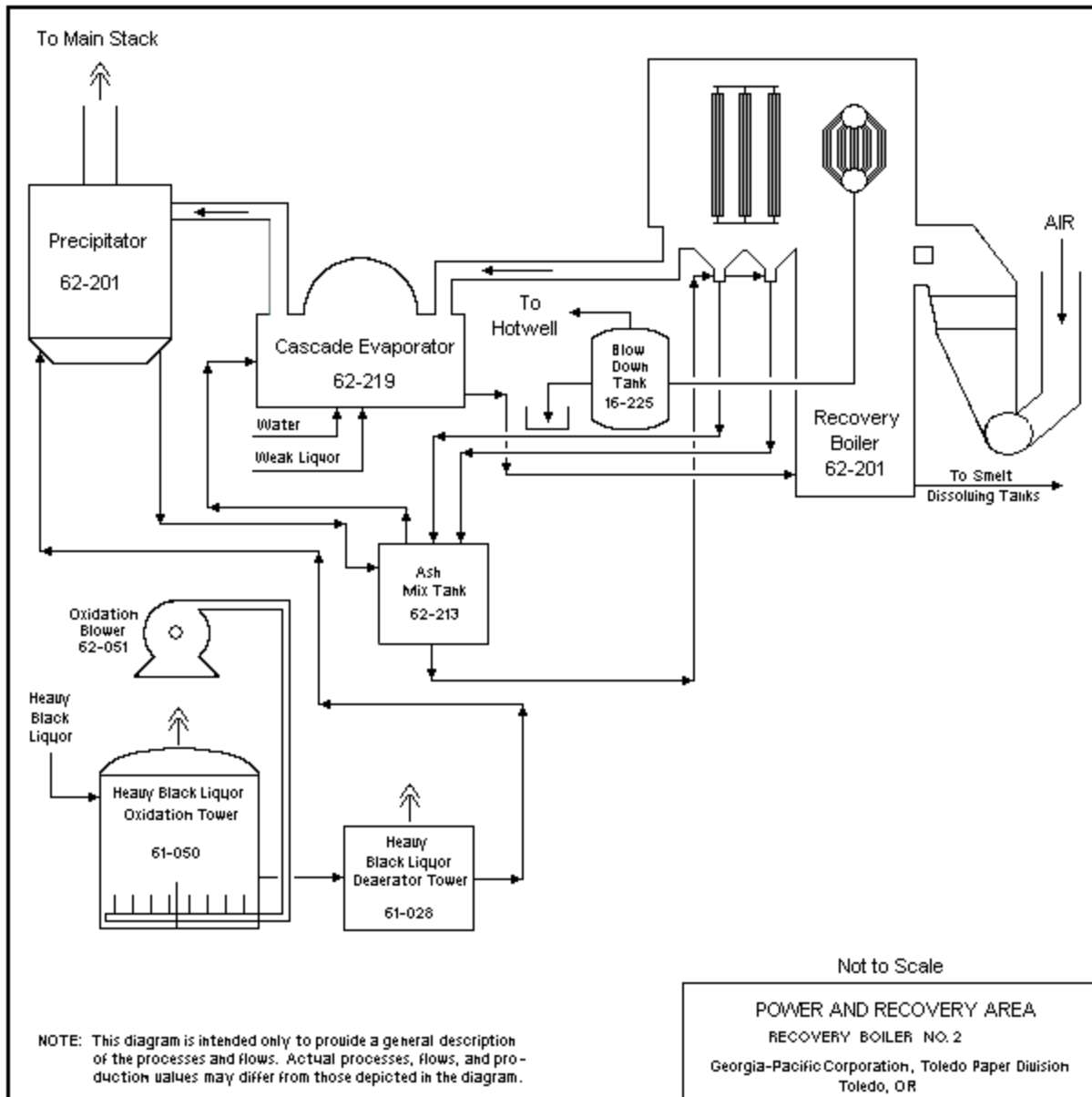

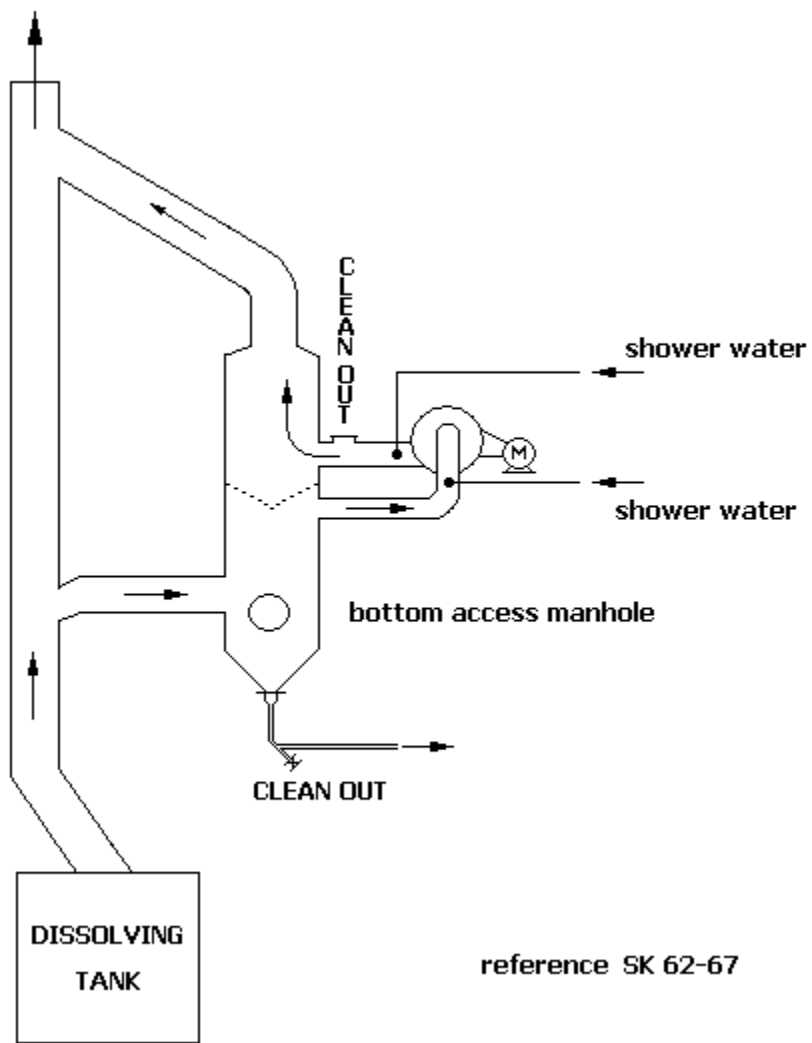

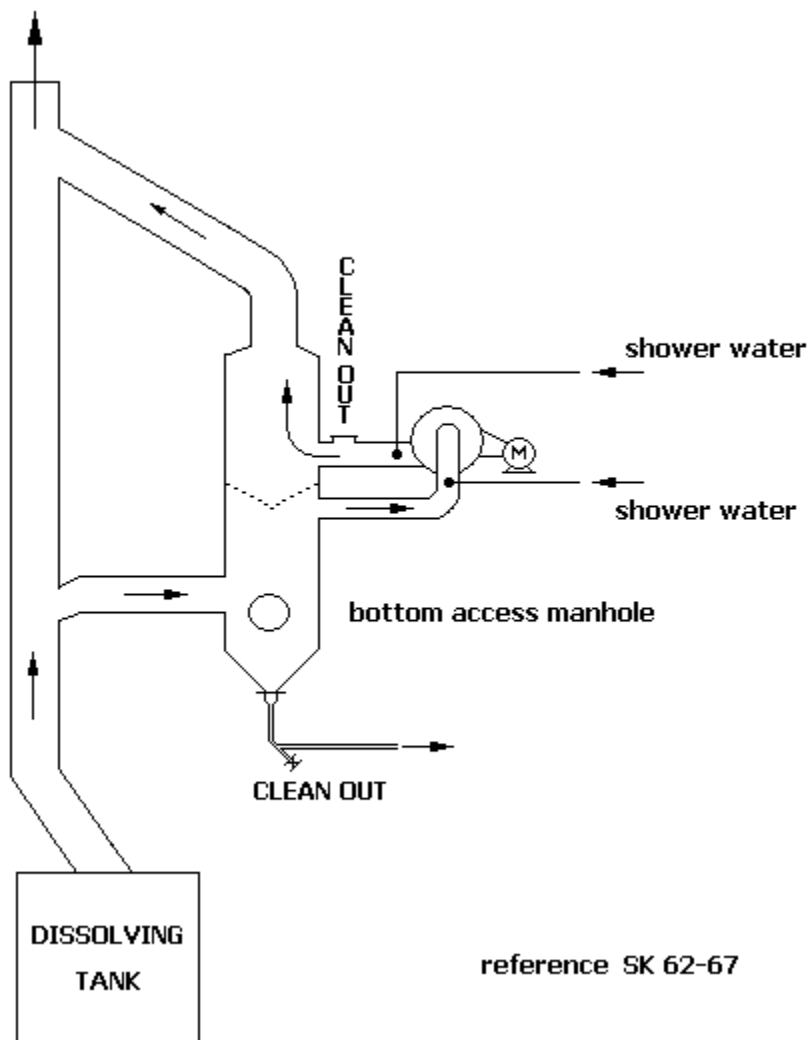

reference SK 62-67

