



## **AGENDA**

CITY COMMISSION OF THE CITY OF WARRENTON  
REGULAR MEETING  
April 27, 2021– 6:00 P.M.  
Warrenton City Commission Chambers – 225 South Main Avenue  
Warrenton, OR 97146

---

Public Meetings will be conducted in the Commission Chambers with a limited seating arrangement. To adhere to social distancing recommendations, meetings will now also be audio and video live streamed. Go to <https://www.ci.warrenton.or.us/administration/page/live-stream-public-meetings> for connection instructions.

1. **CALL TO ORDER**

2. **PLEDGE OF ALLEGIANCE**

3. **CONSENT CALENDAR**

- A. City Commission Work Session Minutes – 4.13.21
- B. City Commission Meeting Minutes – 4.13.21
- C. Warrenton Marinas Advisory Committee Minutes – 3.22.21
- D. Police Department Monthly Statistics – March 2021

Items on the Consent Calendar have previously been discussed and/or are considered routine. Approval of the Consent Calendar requires a motion, a second, and no discussion, unless requested by a member of the City Commission.

4. **COMMISSIONER REPORTS**

**Proclamation – Building Safety Month – May 2021**

**Proclamation – Municipal Clerks Week – May 2 – May 8, 2021**

5. **PUBLIC COMMENT**

At this time, anyone wishing to address the City Commission concerning items of interest may do so. The person addressing the Commission must complete a Public Comment Card and submit it to the City Recorder prior to the meeting. All remarks will be addressed to the whole City Commission and limited to 3 minutes per person. Public Comments may also be

submitted by email to the City Recorder, at [cityrecorder@ci.warrenton.or.us](mailto:cityrecorder@ci.warrenton.or.us), no later than 5:00 p.m. the day of the meeting. The Commission reserves the right to delay any action, if required, until such time as they are fully informed on a matter.

6. **PUBLIC HEARINGS**

- A. Amendment to Warrenton Municipal Code (WMC) Title 16 Development Code; Homestay Lodging and Vacation Rental Dwellings and Amendments to WMC Title 8.24 Homestay Lodging Standards
- B. Amendment to Warrenton Municipal Code (WMC) Title 16 Development Code; Update to Marijuana Businesses

7. **BUSINESS ITEMS**

- A. Consideration of Public Improvement Contract – New Sewer Laterals on Dolphin Ave; Big River Construction
- B. Consideration of Public Improvement Contract – Alder Creek Tide Gate Structure; Bergerson Construction

8. **DISCUSSION ITEMS**

- A. Update on DLCD Grant

9. **GOOD OF THE ORDER**

10. **EXECUTIVE SESSION**

11. **ADJOURNMENT**

Warrenton City Hall is accessible to the disabled. An interpreter for the hearing impaired may be requested under the terms of ORS 192.630 by contacting Dawne Shaw, City Recorder, at 503-861-0823 at least 48 hours in advance of the meeting so appropriate assistance can be provided.

MINUTES  
 Warrenton City Commission  
 Work Session – April 13, 2021  
 5:00 p.m.  
 Warrenton City Hall - Commission Chambers  
 225 S. Main  
 Warrenton, OR 97146

Mayor Balensifer called the work session to order at 5:09 p.m.

City Commissioners Present: Mayor Henry Balensifer (via Zoom), Tom Dyer, Rick Newton, Gerald Poe, and Mark Baldwin

Staff Present: City Manager Linda Engbretson, Public Works Director Collin Stelzig, Public Works Operations Manager Kyle Sharpsteen, Police Chief Mathew Workman, Fire Chief Brian Alsbury, Finance Director April Clark, Deputy City Recorder Rebecca Sprengeler, and City Recorder Dawne Shaw

City Manager Linda Engbretson noted staff have put together the draft Capital Improvement Program (CIP) for 2022 – 2027. This is a living document with anticipated projects for the next six years. She asked for feedback and assistance in prioritizing the projects.

Discussion began about General Fund departments on page 2. Mayor Balensifer noted the Quincy Robinson Trust Board funded projects are funded by an outside entity. The funds cannot be moved around. Mayor Balensifer asked about money earmarked for the Hammond Waterline project. Public Works Director Collin Stelzig clarified that after discussion with Congresswoman Bonomici's office, Public Works is asking for \$1 million for the earmark and using existing loan and grant money from the state. Discussion followed.

Mayor Balensifer requested the Hammond fishing pier plan be added to the CIP; He has been in communication with ODFW (Oregon Department of Fish and Wildlife). The Director is very excited about this project and wants to push it forward putting a bulkhead or pierhead in Seafarer's Park. This would help reclaim lost parking and land, as well as provide handicap accessible fishing and crabbing. Putting it in the CIP allows for a plan that can be referenced in potential, future partnership with the state. The state has already provided rough estimates. Brief discussion continued.

Ms. Engbretson moved the conversation to the Building Department. There is an additional vehicle for the Building Official in the CIP. Brief discussion followed.

Mayor Balensifer directed the conversation to the Tansy Point anodes on page 3. There was discussion on the corrosion of the anodes. The City is not planning to replace the anodes this year.

Mayor Balensifer moved to Storm Sewer and asked about the SRTS (Safe Routes to School) grant. Mr. Stelzig said it will come to the City Commission tonight. Mayor Balensifer noted previous discussion about cost difficulties for sidewalk improvements on Main Avenue due to storm runoff. Mr. Stelzig responded, noting the Otak analysis. An extra storm pump is not needed for Main because of this project.

Mayor Balensifer asked about the tide gate replacement program. Mr. Stelzig said the Commission will have a contract at the next meeting for about \$50,000 for two tide gates at Alder Creek this year. Public Works is hoping to spend money on the 4<sup>th</sup> Street tide gate next year. There are not funds to be proactive about this, therefore it is in the CIP. Mr. Stelzig noted the tide gates and culverts cannot be replaced unless they are replaced with "fish friendly" tide gates. Replacement with a large fish passage will have to be done in the next 10-12 years. Discussion continued on erosion and increased flooding in the Alder Creek area. Discussion followed on the condition and repair process of the tide gates. Mayor Balensifer noted other areas of increased flooding during king tides: Enterprise in Hammond and residential areas near 7<sup>th</sup>. He asked if there is potential for replacement of these tide gates and put in pumps. Mr. Stelzig noted repairs done on the Enterprise tide gate several years ago. There is a project to increase the size of the Hammond storm water line this year to 36 inches. Public Works is also looking to do similar improvement at other areas in the near future. Mr. Stelzig noted a proposed pump station at Vera Slough. The Port is applying for a grant to do research for this. Mayor Balensifer noted he feels Vera Slough is not a good case for this as it was originally an environmental development mitigation project. Mr. Stelzig said there is a proposed pump station in Hammond that has not come to the CIP yet. Mayor Balensifer noted concerns with the tide gates in Hammond flushing sediment into the Marina docks. There was discussion on alternative options for water discharge. Mayor Balensifer asked about the O&M and Alder Monitoring on page 92. Mr. Stelzig said this is in the Stormwater Master Plan. It is local monitoring of rain elevation, drainages, ground waters, etc. Having this data available will be helpful in future tide gate replacement.

Mayor Balensifer asked how long garbage trucks last. Mr. Stelzig noted the City has 3 trucks and is on a 9-year rotation. It was noted how clean the trucks are kept.

Mayor Balensifer asked about police vehicle replacement. He is excited the City is looking at getting the F-150. He has received several comments from constituents about the black vehicles and was curious if there is possibility to start buying in a color other than black. Chief Workman responded that he does not oppose changing the color. He does not prefer to do multi-colored vehicles. OSP (Oregon State Police) is changing to silver. He noted Seaside does a package for their graphics, which is costly; WPD (Warrenton Police Department) does simplistic graphics, locally. He stated he is open to changing and noted he would like to hear from the community on what they would like to see for colors. Discussion continued. The general consensus was to look at alternate colors for the F-150 and to survey the public.

Mayor Balensifer also asked about future plans for evidence storage. Chief Workman noted he is always looking. Options need to be discussed with CIS (Citycounty Insurance Services).

Evidence cannot go offsite for security reasons. Discussion continued about other options for evidence storage. An upper level was mentioned. Concerns about ADA requirements were noted.

Ms. Engbretson gave an overview of the Marinas projects in the CIP. All the projects are funded and have anticipated completion within this next fiscal year. Commissioner Newton discussed liability concerns about a ladder to get on and off the pier. Ms. Engbretson noted it is a question for CIS. Brief discussion continued. Mayor Balensifer asked why there are not more Marina projects outlined in the CIP. Ms. Engbretson noted that historically there has not been much in the CIP for the Marinas. There has been discussion with staff on adding more projects moving forward.

There being no further business, Mayor Balensifer adjourned the work session at 5:59 p.m.

Respectfully prepared and submitted by Rebecca Sprengeler, Deputy City Recorder.

APPROVED:

Henry A. Balensifer III, Mayor

ATTEST:

Dawne Shaw, CMC, City Recorder

MINUTES  
Warrenton City Commission  
April 13, 2021  
6:00 p.m.  
Warrenton City Hall - Commission Chambers  
225 S. Main  
Warrenton, OR 97146

Mayor Pro Tem Dyer called the meeting to order at 6:00 p.m. and led the public in the Pledge of Allegiance.

Commissioners Present: Mayor Pro Tem Tom Dyer, Gerald Poe, Mark Baldwin, and Rick Newton

Excused: Mayor Henry Balensifer

Staff Present: City Manager Linda Engbretson, City Recorder Dawne Shaw, Deputy City Recorder Rebecca Sprengeler, Police Chief Mathew Workman, Public Works Director Collin Stelzig, Public Works Operations Manager Kyle Sharpsteen, Community Development Director Scott Hess, Fire Chief Brian Alsbury, Finance Director April Clark, and Police Detective Tyler Johnston

CONSENT CALENDAR

- A. City Commission Work Session Minutes – 3.23.21
- B. City Commission Meeting Minutes – 3.23.21

City Recorder Dawne Shaw noted a wording change to the 3.23.21 regular meeting minutes.

**Commissioner Poe made the motion to accept the minutes. Motion was seconded and passed unanimously.**

**Newton – aye; Dyer – aye; Poe – aye; Baldwin – aye**

COMMISSIONER REPORTS

Commissioner Newton noted he has enjoyed working with Community Development Director Scott Hess and gave an update on the Pacific Safety Coordination Council (PSCC). He noted the future of the K-9 program. He gave an update on the new jail. He attended the Spruce Up Warrenton Eater Egg Hunt and the Parks Board meeting. He noted two new county liaisons at PSCC to work with people on mental health and mentioned the CAHOOTS bill. Commissioner Newton is now the Vice Chair of PSCC.

Mayor Pro Tem Dyer commented that his brother has been helping with the ballfields and noted the City has been very helpful. He gave kudos to Public Works.

PUBLIC COMMENT – None

PUBLIC HEARING – None

BUSINESS ITEMS

City Manager Linda Engbretson discussed the Police Association Collective Bargaining Agreement. She noted the cost-of-living adjustment (COLA) increases. Negotiations will re-open beginning July 1, 2022.

**Commissioner Poe made the motion to approve the agreement between the City of Warrenton and the Warrenton Public Safety Association and authorize the Mayor and the City Manager to sign the agreement. Motion was seconded and passed unanimously.**

**Newton – aye; Dyer – aye; Poe – aye; Baldwin – aye**

Police Chief Mathew Workman presented a contract for one 2021 F-150 Police Responder 4x4 vehicle. He noted he has been hoping to get a pick-up for a long time. It is needed for bicycles and homeless camp cleanup that current vehicles are not well suited for. He noted this is a performance rated vehicle. The delivery will not take place until the fall because of production delays. Brief discussion followed.

**Commissioner Newton made the motion to allow for the purchase of the F-150. Motion was seconded and passed unanimously.**

**Newton – aye; Dyer – aye; Poe – aye; Baldwin – aye**

Public Works Director Collin Stelzig discussed the Raw Waterline replacement contract with Murraysmith, in the amount of \$87,594.00. He noted this contract is for the design and to bring it to bid. The final design is estimated to be completed in October. Mr. Stelzig made comments about the next phase. Commissioner Newton noted a correction to the wording of the motion. There was brief discussion about project management.

**Commissioner Baldwin made the motion to award the contract to Murraysmith for the Raw Waterline replacement design, with a not-to-exceed price of \$87,594.00. Motion was seconded and passed unanimously.**

**Newton – aye; Dyer – aye; Poe – aye; Baldwin – aye**

Mr. Stelzig presented a grant agreement between the City of Warrenton and the Oregon Department of Transportation's (ODOT) Safe Routes to School Program (SRTS) for the Warrenton Grade School-Main Avenue Safe Pedestrian Walkway Project. He stated they are very excited about getting this grant and the hope is to continue with the grants. He noted one change on page 12. Exhibit A should show a completion date of 2022. The corrected contract has

MINUTES

Warrenton City Commission

Regular Meeting – 4.13.21

Page: 2

not been received yet. It will be submitted for signatures once received. Discussion followed on working with ODOT.

Ms. Engbretson noted several upcoming City projects and gave kudos to Public Works for all their hard work on getting these grants and projects approved. Mr. Stelzig gave kudos to Public Works Analyst Trisha Hayrynen; she has done a fantastic job on this grant.

**Commissioner Newton made the motion to approve the Mayor's signature for the grant agreement between the City of Warrenton and Oregon Department of Transportation's SRTS Program for the Warrenton Grade School to Main Avenue safe pedestrian walkway project. Motion was seconded and passed unanimously.**

**Newton – aye; Dyer – aye; Poe – aye; Baldwin – aye**

DISCUSSION ITEMS – None

GOOD OF THE ORDER

Commissioner Newton participated in Library Day. The Friends of the Warrenton Library has three new members. He attended the CERT (Community Emergency Response Team) meeting and noted improvements. Commissioner Newton noted concerns about the Department of Labor's decision to push 15 families out of houses at Tongue Point. He mentioned his disappointment with changes to SB330. There is an upcoming RDI (Rural Development Initiatives) grant class. Regarding CERT, he noted during the 2007 storm, people would not go to the shelters due to their pets. The Red Cross is working to address this. Commissioner Newton received a letter of from the Ford Family for exceptional community building. He thanked Mayor Balensifer for this.

Mayor Pro Tem Dyer stated he is thankful for a community that is so supportive.

There being no further business, Mayor Pro Tem Dyer adjourned the regular meeting at 6:24 p.m.

Respectfully prepared and submitted by Rebecca Sprengeler, Deputy City Recorder.

APPROVED:

\_\_\_\_\_  
Henry A. Balensifer III, Mayor

ATTEST:

\_\_\_\_\_  
Dawne Shaw, CMC, City Recorder

MINUTES  
Marina Advisory Board  
March 22, 2021  
Warrenton City Hall – Commission Chambers  
225 S Main  
Warrenton, OR 97146

Marina Advisory Board Members Present: Chairperson Pam Ackley, Kevin Dunn, Malcolm Cotte, Lylla Gaebel, Mike Balensifer.

Staff Present: City Manager Linda Engbretson, Harbormaster Jane Sweet, Marina Office Assistant Jessica McDonald

Welcome and thank you message from City Manager Linda Engbretson to all board members for the first Marina Advisory Board Meeting.

Board Member Introductions

Chairperson Pam Ackley – Former City Commissioner, Hammond moorage holder and Marinas/community activist.

Lylla Gaebel – Former Commissioner and community supporter

Malcom Cotte – Warrenton business owner of Fishstix and years of experience in seafood retail

Kevin Dunn – Commercial fishermen and fisheries activist

Mike Balensifer – Gillnet fishermen, river pilot and community supporter

BUSINESS ITEMS

Staff handed out packets to board members containing:

- A) Marina's Budget Overview
- B) List of projects, capital improvements and equipment that the marina needs
- C) Overview of the Marina's rates and comparable

DISCUSSION

The Warrenton Commercial Pier Capital Improvements project repair will cost approx. 1.3 million but the City is hoping to save on that cost because that quote includes a high contingency and the City may save by completing the project in one phase not spreading it out in multiple phases. Warrenton's Urban Renewal is funding 1 million of the cost to repair the pier and Warrenton Marina has about \$400,000 saved for Capital Improvements. Board members were asked if the City can save between \$300,000-\$400,000 on this project what Capital Improvements should be a priority for the Warrenton Marina. Jane Sweet and board members discussed the importance of replacing E Dock's pilings and improvements to parking and lighting were also discussed.

Chairperson Ackley reviewed Hammond Task Force recommendations and highlighted the potential for a recreational fishing pier in the Hammond Marina that Major Henry Balensifer is working on. The board discussed pet waste cleanup stations and the board recommended staff get additional stations. The board recommended making dredge spoil area accessible for additional trailer parking and this would be a step towards the multi-use community center that was in the Hammond Task Force Recommendations.

Rates in the Marinas were discussed, board members began addressing issues with rates and recommendations. Both Marinas face many issues when getting grants, fuel tax or outside funding because of that being a Port. Oregon's Marine Board is only interested in offering funding for transient sport boat docks or temporary tie ups. City Manager Linda Engbretson and Harbormaster Jane Sweet are going to be meeting with Business Oregon to explore loan options for an additional funding source.

Jane Sweet recommended the Warrenton Pier and E dock Piling Replacement to be top priorities moving into budget planning. The Warrenton Marina's parking lots were discussed as a priority; they need to be resurfaced and stripped in most of the parking and dry storage areas. Board

members asked for an estimate on what it would cost to improve the parking areas. Improvements to parking and dry storage would potentially increase revenues.

Hammond Marina has lost the use of the area south of the gazebo in Seafarers Park for overflow camping, this will reduce the Hammond Marinas revenues between \$12,000-\$20,000 for the upcoming year.

Board recommended getting water, sewer and electric near Sturgeon Paul's to allow for a year around camp host to help with restrooms and garbage in the Marina. Chairperson Ackley suggested planting trees in front of Paul's dry storage area to enrich the area, possible donations or planting event.

Board went through rates and made the following recommendations:

1. Camping increase to \$50
2. Labor equal to cost of employee with benefits x2
3. Dry Storage increase to \$95
4. Late fee increase to \$10 +1.5%
5. Hoist increase to \$100
6. Electrical meter read fee increase to \$15
7. Additional parking pass for annual moorage holders \$100
8. Key replacement increase to \$25
9. Unauthorized living aboard vessel \$200

All board members stressed the importance of dock improvements when rates are increasing.

Next meeting set for April 19<sup>th</sup>, 2021 at 2pm in Commission Chambers at City Hall to continue discussing changes to rates and finalize board's rate recommendations.



**WARRENTON POLICE DEPARTMENT**  
**MARCH 2021 STATISTICS**  
 APRIL 27, 2021



March Statistics (% changes are compared to 2019)							
Category	2021	2020	%Chg	2019	%Chg	2018	%Chg
Calls for Service	772	592	30%	760	2%	763	1%
Incident Reports	195	149	31%	196	-1%	167	17%
Arrests/Citations	181	166	9%	200	-10%	84	115%
Traffic Stops/ Events	142	156	-9%	234	-39%	188	-24%
DUII's	6	2	200%	6	0%	3	100%
Traffic Accidents	9	12	-25%	8	13%	18	-50%
Property Crimes	96	82	17%	78	23%	58	66%
Person Crimes	80	56	43%	67	19%	62	29%
Drug/Narcotics Calls	2	3	-33%	8	-75%	8	-75%
Animal Calls	22	6	267%	20	10%	23	-4%
Officer O.T.	63.25	215.7	-71%	86.45	-27%	64.4	-2%
Reserve Hours	0	0	0%	26.5	-100%	13	-100%

Category	Jan	Feb	Mar	Apr	May	Jun	Jul	Aug	Sep
Calls for Service	682	682	772						
Incident Reports	218	218	195						
Arrests/Citations	214	196	181						
Traffic Stops/ Events	107	107	142						
DUII's	1	1	6						
Traffic Accidents	17	17	9						
Property Crimes	111	111	96						
Person Crimes	109	78	80						
Drug/Narcotics Calls	9	10	2						
Animal Calls	19	17	22						
Officer O.T.	19.5	72.25	63.25						
Reserve Hours	0	0	0						

Oct	Nov	Dec	2021 YTD	2021 Estimate	2020	2021v 2020	2019	2021v. 2019	2018	2021v. 2018
			2136	8544	7955	7%	9270	-8%	9819	-13%
			631	2524	2442	3%	2469	2%	2608	-3%
			591	2364	1891	25%	2095	13%	1731	37%
			356	1424	2000	-29%	2489	-43%	2627	-46%
			8	32	27	19%	36	-11%	33	-3%
			43	172	228	-25%	246	-30%	275	-37%
			318	1272	1191	7%	1230	3%	1094	16%
			267	1068	830	29%	863	24%	849	26%
			21	84	58	45%	86	-2%	117	-28%
			58	232	207	12%	289	-20%	271	-14%
			155	620	2075.4	-70%	2194.5	-72%	1731.7	-64%
			0	0	12.5	-100%	259.5	-100%	359.5	-100%

Homeless Incidents	2021	2020
Code 40 (Normal)	22	26
Code 41 (Aggressive)	1	1

Elk Incidents	2021
Interaction:	1
Traffic Accidents:	0
Traffic Complaints:	1
<b>Total:</b>	<b>2</b>

The following is a graphic representation of statistics for **March 2021** using our **CityProject** membership (formerly [CrimeReports.com](https://www.crimereports.com)). The "Dots" represent a location of a call and if you would zoom in on the map you would see an icon for the type of call and some basic time/date details. Some dots represent multiple calls at one location. If you go to the website, you can zoom in on each incident for more details.

- |  |  |  |  |
|--|--|--|--|
| <input checked="" type="checkbox"/> Assault                    | <input checked="" type="checkbox"/> Property & Theft           | <input checked="" type="checkbox"/> Disorder/Disturbance | <input checked="" type="checkbox"/> 911 or Other       |
| <input checked="" type="checkbox"/> Assault                    | <input checked="" type="checkbox"/> Property Crime             | <input checked="" type="checkbox"/> Disorder             | <input checked="" type="checkbox"/> Community Events   |
| <input checked="" type="checkbox"/> Assault with Deadly Weapon | <input checked="" type="checkbox"/> Breaking & Entering        | <input checked="" type="checkbox"/> Disorder             | <input checked="" type="checkbox"/> Community Policing |
| <input checked="" type="checkbox"/> Sexual Offense             | <input checked="" type="checkbox"/> Property Crime Commercial  | <input checked="" type="checkbox"/> Drugs                | <input checked="" type="checkbox"/> Proactive Policing |
| <input checked="" type="checkbox"/> Sexual Assault             | <input checked="" type="checkbox"/> Property Crime Residential | <input checked="" type="checkbox"/> Drugs                | <input checked="" type="checkbox"/> Emergency          |
| <input checked="" type="checkbox"/> Sexual Offense             | <input checked="" type="checkbox"/> Other Property Crime       | <input checked="" type="checkbox"/> Liquor               | <input checked="" type="checkbox"/> Emergency          |
| <input checked="" type="checkbox"/> Other Sexual Offense       | <input checked="" type="checkbox"/> Theft                      | <input checked="" type="checkbox"/> Liquor               | <input checked="" type="checkbox"/> Fire               |
| <input checked="" type="checkbox"/> Other Violent Offense      | <input checked="" type="checkbox"/> Theft from Vehicle         | <input checked="" type="checkbox"/> Quality of Life      | <input checked="" type="checkbox"/> Fire               |
| <input checked="" type="checkbox"/> Homicide                   | <input checked="" type="checkbox"/> Theft of Vehicle           | <input checked="" type="checkbox"/> Quality of Life      | <input checked="" type="checkbox"/> Police Calls       |
| <input checked="" type="checkbox"/> Kidnapping                 | <input checked="" type="checkbox"/> Other Theft                |  |  |
| <input checked="" type="checkbox"/> Robbery                    |  |  |  |



## ***Proclamation***

### ***Building Safety Month — May 2021***

**Whereas**, the City of Warrenton is committed to recognizing that our growth and strength depends on the safety and economic value of the homes, buildings and infrastructure that serve our citizens, both in everyday life and in times of disaster, and;

**Whereas**, our confidence in the resilience of these buildings that make up our community is achieved through the devotion of vigilant guardians - building safety and fire prevention officials, architects, engineers, builders, tradespeople, design professionals, laborers, plumbers and others in the construction industry - who work year-round to ensure the safe construction of buildings, and;

**Whereas**, these guardians are dedicated members of the International Code Council, a nonprofit that brings together local, state and federal officials that are experts in the built environment to create and implement the highest-quality codes to protect us in the buildings where we live, learn, work, play, and;

**Whereas**, our nation benefits economically and technologically from using the International Codes that are developed by a national, voluntary consensus codes and standards developing organization, our government is able to avoid the high cost and complexity of developing and maintaining these codes, which are the most widely adopted building safety and fire prevention codes in the world;

**Whereas**, these modern building codes include safeguards to protect the public from hazards such as hurricanes, snowstorms, tornadoes, wildland fires, floods and earthquakes, and;

**Whereas**, Building Safety Month is sponsored by the International Code Council to remind the public about the critical role of our communities' largely unknown protectors of public safety—our local code officials—who assure us of safe, sustainable, energy efficient and livable buildings that are essential to America's prosperity, and;

**Whereas**, "Prevent, Prepare, Protect. Building Codes Save," the theme for Building Safety Month 2021, encourages all Americans to raise awareness about the importance of safe and resilient construction; fire prevention; disaster mitigation, energy conservation; water safety; training the next generation; and new technologies in the construction industry.

**Whereas**, each year, in observance of Building Safety Month, people all over the world are asked to consider the commitment to improve building safety, resilience and economic investment at home and in the community, and to acknowledge the essential service provided to all of us by local and state building departments, fire prevention bureaus and federal agencies in protecting lives and property.

**NOW, THEREFORE**, I, Henry A. Balensifer III, Mayor of the City of Warrenton, do hereby proclaim the month of May 2021 as Building Safety Month in the City of Warrenton and I encourage our citizens to join with their communities in participation in Building Safety Month activities.

**IN WITNESS WHEREOF**, I have here unto set my hand and caused to be affixed the Seal of the City of Warrenton, Oregon to be affixed on this 27<sup>th</sup> day of April, 2021.

---

Henry A. Balensifer III, Mayor

Attest:

---

Dawne Shaw, City Recorder

## ***Proclamation***

### ***52nd ANNUAL PROFESSIONAL MUNICIPAL CLERKS WEEK***

***May 2 - May 8, 2021***

**Whereas**, The Office of the Professional Municipal Clerk, a time honored and vital part of local government exists throughout the world, and;

**Whereas**, The Office of the Professional Municipal Clerk is the oldest among public servants, and;

**Whereas**, The Office of the Professional Municipal Clerk provides the professional link between the citizens, the local governing bodies and agencies of government at other levels, and;

**Whereas**, Professional Municipal Clerks have pledged to be ever mindful of their neutrality and impartiality, rendering equal service to all, and;

**Whereas**, The Professional Municipal Clerk serves as the information center on functions of local government and community, and;

**Whereas**, Professional Municipal Clerks continually strive to improve the administration of the affairs of the Office of the Professional Municipal Clerk through participation in education programs, seminars, workshops and the annual meetings of their state, provincial, county and international professional organizations, and;

**Whereas**, It is most appropriate that we recognize the accomplishments of the Office of the Professional Municipal Clerk.

**Now, Therefore**, I, Henry A. Balensifer III, Mayor of the City of Warrenton, do hereby declare the week of May 2 through May 8, 2021, as **Professional Municipal Clerks Week**, and further extend appreciation to our Professional Municipal Clerks - City Recorder, Dawne Shaw and Deputy City Recorder, Rebecca Sprengeler, and to all Professional Municipal Clerks and Recorders for the vital services they perform and their exemplary dedication to the communities they represent.

**IN WITNESS WHEREOF**, I have here unto set my hand and caused to be affixed the Seal of the City of Warrenton, Oregon to be affixed on this 27<sup>th</sup> day of April, 2021.

---

Henry A. Balensifer III, Mayor

Attest:

---

Dawne Shaw, City Recorder



P. O. BOX 250 ■ WARRENTON, OR 97146 - 0250 ■ OFFICE: 503.861.2233 ■ FAX: 503.861.2351

---

April 27, 2021

To: Warrenton Planning Commission

From: Scott Hess, Community Development Director

Re: Amendment to Warrenton Municipal Code (WMC) Title 16 Development Code, Division 2 Land Use Districts to include Homestay Lodging and Vacation Rental Dwellings (File: DCR 21-1 – Ordinance 1248) – Amendments to WMC Title 8.24 Homestay Lodging Standards (Ordinance 1250)

**Summary:** These proposed development code amendments insert Homestay Lodging and Vacation Rental Dwellings as permitted or conditional uses into Title 16, Division 2 Land Use Districts, as referenced by Warrenton Municipal Code (WMC) 8.24.020 Homestay Lodging. Currently, WMC Chapter 8 describes the Homestay Lodging Safety Regulations, and indicates that Homestay Lodging is permitted in certain residential zones per Title 16, Division 2. However, Title 16 is silent on Homestay Lodging and Vacation Rental Dwellings. These code amendments will correct that missing reference.

Further, this code amendment recommends changes to WMC 16.180.040 Accessory Dwelling Standards to amend provision C to allow the ADU to be rented so long as the main home is owner occupied. This provides consistency with the current WMC Chapter 8 Definition of Homestay Lodging and Vacation Rental Dwelling. Staff believes that the owner-occupied provision for Homestay Lodging ADU rentals will assist in maintaining properties in a compatible way with existing neighborhoods.

The Planning Commission held a public hearing on the proposed code amendments at the March 11, 2021 Planning Commission meeting. Staff did not receive any public comments or written responses for this item.

**Proposed Amendments: Definitions**

Staff recommends that Warrenton Municipal Code 16.12.010 Definitions be amended to include Homestay Lodging and Vacation Rental Dwelling as defined by WMC 8.24.020 Homestay Lodging. The definitions which are consistent with Warrenton Municipal Code Chapter 8 are proposed as follows:

- Homestay Lodging. A short-term rental in an owner-occupied, single-family detached dwelling unit using up to five bedrooms, including bedrooms in accessory dwellings.
- Vacation Rental Dwelling. A single-family dwelling or accessory dwelling that is nonowner occupied and is rented for terms of less than 30 days.

#### **Proposed Amendments: Homestay Lodging**

Staff recommends that Homestay Lodging be listed as a **Permitted Use** in the following zones with the language to read:

“Homestay Lodging subject to the standards in Chapter 8.24”

Division 2 Land Use Districts, Permitted Uses affected:

- Low Density Residential (R-40) District, 16.24.020 “add as provision P”
- Intermediate Density Residential (R-10) District, 16.28.020 “add as provision Q”
- Medium Density Residential (R-M) District, 16.32.020 “add as provision R”
- High Density Residential (R-H) District, 16.36.020 “add as provision R”
- General Commercial (C-1) District, 16.40.020 A & B “add as provision A,21 and B,24”  
*Move existing provision A,21 and B,24 “Similar uses as those stated above” to the bottom of the list*
- Commercial Mixed Use (C-MU) District, 16.44.020 A “add as provision 7”

Staff recommends that Vacation Rental Dwellings be listed as **Permitted Use** in the following zones with language to read:

“Vacation Rental Dwelling subject to the Safety Regulations in Chapter 8.24.030”

Division 2 Land Use Districts, Permitted Uses affected:

- General Commercial (C-1) District, 16.40.020 A&B “add as provision A,22 and B,25”  
*Move existing provision A,21 and B,24 “Similar uses as those stated above” to the bottom of the list*

Staff recommends that Vacation Rental Dwellings be listed as **Conditional Use** in the following zones with language to read:

“Vacation Rental Dwelling subject to the Safety Regulations in Chapter 8.24.030”

- Commercial Mixed Use (C-MU) District, 16.44.030 “add as provision H” *Move existing provision H “Similar uses as those listed in this section” to the bottom of the list*

- Recreational-Commercial (R-C) District, 16.56.030 “add as provision M” *Move existing provision M “Similar uses as those listed in this section” to the bottom of the list*

Staff recommends that the limitation on renting an Accessory Dwelling Standards 16.180.040 be amended as follows:

Current Statute:

C. Rental Unit Prohibited. Accessory dwellings are never appropriate for use as a rental unit or other income-producing unit. Accessory dwellings shall not be used as servants’ quarters or as lodging (temporary or permanent) for housekeepers, gardeners, etc. Use of an accessory dwelling for purposes other than what is expressly permitted in this section is strictly prohibited and shall be subject to the enforcement and penalty provisions of Chapter 16.16.

Recommended Amended Language:

C. Rental Unit. *Accessory dwellings may be rented long term as a permitted use. Accessory dwellings may be rented as part of a permitted Homestay Lodging use so long as the main structure of the property is owner-occupied. Use of an accessory dwelling for purposes other than what is expressly permitted in this section is strictly prohibited and shall be subject to the enforcement and penalty provisions of Chapter 16.16.*

---

### **Ordinance 1250 – Title 8 Homestay Lodging Safety Regulations Amendments**

Additional Research and Recommendations: The Planning Commission asked staff to consider additional amendments regarding parking, rental provisions in ADUs, and requiring a consistent contact person for code enforcement.

The City’s Homestay Safety Regulations are a component of Title 8, Health and Safety. The Planning Commission’s responsibility is over Title 16, Development Code, but as a recommending body of the City, staff requested that the PC consider recommendations for action to the City Commission who hears and amends all other Titles of the Municipal Code including Title 8. Keeping the Homestay provisions all within Title 8 will retain consistency and simplicity as opposed to developing a new chapter in Title 16.

Staff reviewed Homestay provisions from Gearhart, Astoria, and Cannon Beach and presented model language to the Planning Commission. Planning Commission considered the following additions to be made in Title 8.24.030 Safety Regulations.

Contact Person and Parking:

**Proposed amendments: Safety Regulations**

Staff recommends the following provision be amended regarding Parking, and an additional provision be added to the list of Safety Regulations for Homestay Lodging Permits.

- Amend number 12. Parking:
  - Provide one off-street parking space per guest bedroom. The approved off-street parking space must remain available for renters. A parking diagram of the approved parking spaces must be provided to renters and be available in a prominent location within the dwelling. Parking stalls shall meet the minimum standards of Section 16.128.030.
  
- Add provision 17. 24-Hour representative:
  - 24-hour Representative: The vacation rental owner and designated representative's name, physical address, email address and phone number must be provided to the City upon permit application and renewal. The information shall be kept current at all times. The owner or representative shall be available by phone (24 hours a day, seven days a week) to ensure a response to complaints regarding emergencies and the condition, operation, or conduct of the occupants. A 24-hour representative must be able to physically respond to the vacation rental site within 30 minutes, and if requested they must respond. If there is a change in the designated representative the property owner must submit to the City the name of the new representative.

Rental Provisions:

Staff is providing for the City Commission's review a document titled: "Guidance on Implementing the Accessory Dwelling Units (ADU) Requirement under Oregon State Bill 1050, Updated to include HB 2001 (2019)."

Staff reviewed Warrenton City's current ADU requirements against the document, and believes that the City has adequately addressed the rental component of ADUs. Standard long-term rentals are regulated differently than Homestay Lodging. The additional right of a homeowner to operate a Homestay Lodging as an owner-occupied short-term rental provides the City with the ability to further regulate items such as parking and safety regulations that help mitigate the negative impacts these uses can have within residential zones.

**Public Process, Procedures & Public Notice:** The Community Development Director has the authority to initiate a text amendment according to WMC 16.208.070.D, General Provisions.

This proposal is being reviewed pursuant to WMC 16.208.060, Type IV Procedure (Legislative and Map Amendments). Also applicable are the statewide planning goals, and the Comprehensive Plan. Draft Findings for the Comprehensive Plan and Statewide Planning Goals have been prepared for the Planning Commission's consideration.

Notice of the Planning Commission public hearing was sent to DLCD on February 4, 2020, letters were not mailed as this is a city-wide code clean-up that does not include any individually affected property owners, and notice was published in *The Daily Astorian* on February 27, 2021 as required prior to the March 11, 2021 Planning Commission meeting. No written comments have been received as of the writing of this staff report.

The Planning Commission recommended approval of these Development Code amendments at their March 11, 2021 meeting. The City Commission will not consider the Planning Commission's recommendation, conduct a public hearing, and make a final decision on the proposed amendment.

**Recommendation:** Staff recommends the City Commission hold a public hearing for the first reading of Ordinance 1248, and Ordinance 1250. Staff recommends approval of the Ordinance Amendments as drafted. The City Commission may take the following action: Approve as presented, Approve with amendments, or Deny. A recommended motion is below:

*"I motion to approve DCR 21-1, Ordinance 1248, to amend Warrenton Municipal Code (WMC) Title 16 Development Code, Division 2 Land Use Districts to include Homestay Lodging and Vacation Rental Dwellings, and recommend amendments to WMC 16.180.040 Accessory Dwelling Standards, provision C to allow an ADU to be rented so long as the main home is owner occupied, as presented in the Staff Report and Draft Findings."*

*"I motion to approve Ordinance 1250, to amend Warrenton Municipal Code (WMC) Title 8 Health and Safety, Chapter 24 Homestay Lodging, to update parking requirements and add the provision for a 24-hour representative, as presented in the Staff Report and Ordinance."*

**Attachments:**

- Findings, DCR 21-1 - Ordinance 1248
- Ordinance 1250
- Guidance on Implementing the Accessory Dwelling Units (ADU) Requirement under Oregon State Bill 1050, Updated to include HB 2001 (2019)

Approved by City Manager

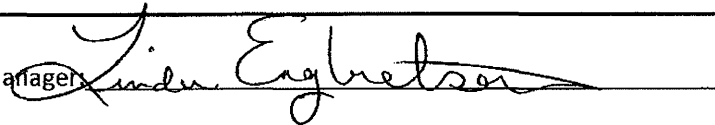

All supporting documentation, i.e., maps, exhibits, etc., must be attached to this memorandum.



## DRAFT Findings, DCR 21-1 - Ordinance 1248

### Comprehensive Plan, Article 10 Procedures

#### SECTION 10.100 FINDINGS

##### Section 10.200 Goals

*Establish a comprehensive planning process which benefits the public as a whole by ensuring the opportunity for local citizens to be involved during all phases of the process, requiring an adequate factual basis for decisions and actions, achieving a desirable level of coordination and consistency with other governmental bodies, and providing a suitable balance between stability and change. (Comprehensive Plan Section 10.200, Procedures, Goals)*

This goal is implemented, in part, through the various types of decision-making procedures described in the Development Code. The amendments to insert Homestay Lodging and Vacation Rental Dwellings as permitted or conditional uses into Title 16, Division 2 Land Use Districts, as referenced by Warrenton Municipal Code (WMC) 8.24.020 Homestay Lodging does not conflict with this policy because it does not reduce or curtail opportunities for citizen involvement in the planning process; nor does the amendment compromise the requirement for an adequate factual basis for decisions and actions; nor does the amendment change the balance between stability and change.

#### SECTION 10.300 POLICIES

##### Section 10.310 Plan Review and Update

*Effective review and updating of the Comprehensive Plan will be carried out through extensive involvement of the Planning Commission. (Comprehensive Plan Section 10.310, Procedures, Policy 1)*

Policy 1 assures that the Planning Commission is involved in comprehensive plan amendments. The proposed amendment does not reduce the Planning Commission's role; nor does it change the way the City develops and reviews comprehensive plan amendments. Comprehensive plan amendments are handled under a Type IV procedure. This amendment affects only Type III decisions. Based on this, the City Commission finds the amendment consistent with policy 1.

*The City will undertake a major review of its Comprehensive Plan in accordance with the State mandated periodic review schedule. The City will make other revisions to the Comprehensive Plan as necessary to address local needs and concerns. (Comprehensive Plan Section 10.310, Procedures, Policy 2)*

The amendment does not alter the City's ability to consider Comprehensive Plan amendments at any time. Note that the State-mandated periodic review schedule described in policy 2 is no longer in effect. Comprehensive Plan amendments are handled under a Type IV procedure. This amendment affects only Type I (permitted use) and Type III (conditional use) decisions. Based on this, the City Commission finds the amendment consistent with this policy.

*All Comprehensive Plan amendments shall comply with the Statewide Planning Goals and will be supported by adequate evidence indicating the desirability of the proposed revisions. The desirability of changes in the intent or boundaries of land and water use areas, as shown on the respective maps, will be determined in part by (a) the expected impact on the ability of the Plan to help satisfy land and water use needs; (b) the improvements to transportation facilities and community facilities and services, if any, necessary to accommodate the change; and (c) the physical development limitation and other natural feature characteristics of the areas involved. (Comprehensive Plan Section 10.310, Procedures, Policy 3)*

Policy 3 requires that the amendment complies with the applicable statewide planning goals. These are addressed below in these findings.

Policy 3 also requires evidence indicating the desirability of the proposed revisions. The amendment will clarify which zones Homestay Lodging and Vacation Rental Dwellings are permitted in Warrenton City. This amendment will allow the Staff and Planning Commission to fully consider any detrimental effects these businesses may have on Warrenton property owners, and will allow a process to effectively condition approvals to mitigate concerns.

Housing on the North Coast is both limited in supply and expensive. These code changes will restrict the ability of stand along single-family homes in residentially zoned areas to be made into Short Term Vacation Rentals, thereby helping to preserve housing stock. The allowance of Homestay Lodging permits for owner-occupied single-family home owners will provide a small increase in beneficial Transient Room Tax for the City of Warrenton, and will also provide an ability to generate revenue and offset housing costs for home owners.

Policy 3 also addresses map amendments. This amendment is to the text of the zoning ordinance, and has no impact on amendments to the zoning map or comprehensive plan map.

For these reasons, the City Commission finds the amendment consistent with policy 3.

*Amendments to the Comprehensive Plan text or map may be initiated by the City Commission, Planning Commission, Community Development Director, any City resident*

*or any person or organization owning real property in the City. The person proposing the amendments will be responsible for providing justification for the revisions, and will also be responsible for providing a form of notice and for the text of any exception language, should such be necessary to meet Statewide Planning Goals. (Comprehensive Plan Section 10.310, Procedures, Policy 4)*

This amendment was initiated by the Community Development Director at the direction of the City Commission. The justification for the revision is that it provides clarity to a missing code reference in Title 8. The amendment further clarifies where Short Term Rentals of various kinds can be approved in the City. Having a clear understanding of these rentals provides assurance that the City is preserving vital housing stock as owner occupied or long-term rentals. The language in policy 4 referring to exception language is not relevant to this amendment. Based on this, the City Commission finds the amendment consistent with policy 4.

*The Planning Commission and the City Commission shall hold public hearings on proposed amendments to the Comprehensive Plan or map. Notice of public hearings will be given in accordance with Development Code requirements. (Comprehensive Plan Section 10.310, Procedures, Policy 5)*

The amendment does not alter the notice and hearing requirements in policy 4. The adoption procedure for DCR 21-1 followed the Development Code's applicable Type IV requirements. The amendment affects only Type I (permitted uses) and Type III (conditional use permit) decisions. Based on this, the City Commission finds the amendment consistent with policy 5.

*For purposes of reviewing and updating the Comprehensive Plan, the Planning Commission will be the officially recognized committee for citizen involvement. It will be appointed in an open and public manner and its membership shall be representative of a broad range of geographical, cultural and economic elements of the population in the Warrenton area. Adequate resources will be allocated for its activities and other citizen involvement efforts. (Comprehensive Plan Section 10.310, Procedures, Policy 6)*

The amendment does not change the Planning Commission's role as the committee for citizen involvement in Comprehensive Plan reviews and updates; nor does the amendment alter the method for appointing Planning Commissioners. The City provides adequate financial resources for citizen involvement efforts through its budget process; the amendment does not change this. For these reasons, the City Commission finds the amendment consistent with policy 6.

*The Planning Commission and City staff will provide the general public with an opportunity to be involved in inventory work, plan revisions and plan implementation. Efforts will be undertaken to respond to citizen suggestions and make technical information and minutes of meetings available to the general public. (Comprehensive Plan Section 10.310, Procedures, Policy 7)*

The amendment does not reduce opportunities for the public to be involved in inventory work, comprehensive plan revisions, and plan implementation. The City makes agendas, staff reports, and Planning Commission minutes available on its website, and at City Hall. The amendment does not alter the availability of technical information and meeting minutes. Based on this, the City Commission finds that the amendment does not conflict with policy 7.

*When reviewing and updating the Comprehensive Plan, the City will attempt to (a) give ample consideration to the comments and concerns of other governmental bodies; (b) achieve consistency with their policies to the extent appropriate; and (c) avoid unnecessary overlapping responsibilities. Affected special districts and appropriate local, regional, state and federal agencies will be notified by mail of public hearings on Comprehensive Plan amendments. (Comprehensive Plan Section 10.310, Procedures, Policy 8)*

This policy addresses Comprehensive Plan reviews and updates. Reviews are work session items. Updates are considered under a Type IV procedure. The amendment addresses Type I (permitted uses) and Type III (conditional use permit) decisions. The policy is not applicable to the proposed amendment.

#### **Section 10.320 Plan Implementation**

*Implementation will occur in a manner which makes possible meaningful participation by local citizens and interested governmental bodies; consistency between the Plan and implementation measures intended to fulfill Plan objectives; and periodic review and update of these controls. (Comprehensive Plan Section 10.320, Plan Implementation, Policy 1)*

The amendment does not detract from the policy of ensuring meaningful participation in the implementation of the Comprehensive Plan. The amendment does not alter any other implementation measures related to citizen participation.

The amendment does not create an inconsistency between the Development Code and the Comprehensive Plan. As shown by these findings, the amendment does not conflict with applicable Comprehensive Plan policies.

The amendment does not interfere with the City's effort to review and update the Comprehensive Plan and Development Code. These updates are considered under a Type IV procedure; the amendment modifies the Development Code's Type I (permitted uses) and Type III (conditional use permit) decisions.

For these reasons, the City Commission finds the amendment consistent with Plan Implementation policy 1.

*Major actions undertaken to implement the Comprehensive Plan shall take place in a well-publicized, open atmosphere. The Planning Commission, general public and interested governmental bodies will be given an opportunity to comment on these actions before they are carried out. (Comprehensive Plan Section 10.320, Plan Implementation, Policy 2)*

The Comprehensive Plan is implemented through the Development Code and the Zoning Map, so *major actions to implement the comprehensive plan* include development code amendments, such as this one. This amendment and the hearings before the Planning Commission have been well-publicized by posting in The Daily Astorian, and on the City's website. Additionally, the amendment has been posted on the Oregon Department of Land Conservation and Development's website. The general public and interested governmental bodies had the opportunity to comment on the amendment. The Planning Commission's recommendation was received by the City Commission at a public hearing on April 27, 2021. The City Commission finds that the amendment's adoption process was consistent with the procedural requirements of Plan Implementation policy 2, as implemented through the City's Development Code. The City Commission further finds that the amendment is consistent with Policy 2 because it does not alter the requirements of policy 2: the amendment affects only Type I (permitted uses) and Type III (conditional use permit) matters, not Development Code or Zoning Map amendments, which are considered under Type IV procedures.

*Provisions of the zoning ordinance, subdivision and partitioning regulations and other land and water use controls used to implement the Plan shall be consistent with the Plan. This does not mean, however, that these provisions have to be specifically authorized by the Plan or cannot be more detailed than those in the Plan. (Comprehensive Plan Section 10.320, Plan Implementation, Policy 3)*

The consistency requirement in policy 3 is not violated by the amendment because the decision-making process exists within the development code, and nowhere else in the City's planning documents. For this reason, the City Commission finds the amendment consistent with Plan Implementation policy 3.

*Land and water use controls used to implement the Plan will be periodically reviewed and updated. Before changes in the regulations are adopted, there will be at least one public hearing on the proposal and adequate public notice of every hearing. (Comprehensive Plan Section 10.320, Plan Implementation, Policy 4)*

The *land and water use controls* that implement the Comprehensive Plan are the Development Code and the Zoning Map. The Planning Commission considered this Development Code amendment at a public hearing on March 11, 2021. The hearing was advertised in The Daily Astorian on February 27, 2021, and on the City's website. The amendment does not alter the hearing or public notice requirements for Development Code or Zoning Map amendments. As noted elsewhere in these findings, the amendment has no impact on Development Code or Zoning Map amendments, which are heard under a Type IV procedure, because the

amendment affects the Type I (permitted uses) and Type III (conditional use permit) land use decisions only. Based on this, the City Commission finds the amendment consistent with the requirements of Plan Implementation policy 4.

#### **Statewide Planning Goal 1, Citizen Involvement**

Goal 1 is: *To develop a citizen involvement program that ensures the opportunity for citizens to be involved in all phases of the planning process.* The development code amendment was reviewed in accordance with the acknowledged provisions for citizen involvement in Warrenton's municipal code, which implement goal 1. The amendment does not restrict opportunities for citizen involvement. The Development Code's requirements for advertising and hearings are unchanged. Opportunities for citizens to appeal land use decisions are not restricted or narrowed by the amendment. Based on this, the City Commission finds that the amendment is consistent with Statewide Planning Goal 1.

#### **Statewide Planning Goal 2, Land Use Planning**

Goal 2 requires that local governments *"establish a land use planning process and policy framework as a basis for all decisions and actions related to use of land and to assure an adequate factual base for such decisions and actions."* The amendment fits into the City's land use planning processes and policy framework. The amendment clarifies in what zoning districts Homestay Lodging and Vacation Rental Dwellings are permitted in Title 16, Division 2. The amendment does not alter the basic framework for planning and decision-making in Warrenton. The amendment takes into account the Buildable Lands Inventory and Housing Needs Assessment to encourage owner-occupied and long-term rental housing. The need for housing for residents is balanced by the option of Homestay Lodging which provides a potential revenue source for home owners who have available rooms within their existing homes or Accessory Dwellings to rent. Based on this, the City Commission finds the amendment consistent with Statewide Planning Goal 2.

#### **Statewide Planning Goal 3, Agricultural Lands**

Not applicable

#### **Statewide Planning Goal 4, Forest Lands**

Not applicable

#### **Statewide Planning Goal 5, Natural Resources, Scenic and Historic Areas, and Open Spaces**

The basic aim of Goal 5 is *"To protect natural resources and conserve scenic and historic areas and open spaces."* The City's goal 5 implementation measures in its Comprehensive Plan and Development Code are unaffected by the proposed amendment. Goal 5 protection measures

remain in force in those areas affected by these amendments. The amendment does not add any new resources to the City's Goal 5 inventories, or take any resources out of these inventories, or alter prior decisions concerning those goal 5 resources. Based on this, the City Commission finds the amendment consistent with Statewide Planning Goal 5.

#### **Statewide Planning Goal 6, Air, Water and Land Resources**

Goal 6 is *"to maintain and improve the quality of the air, water and land resources of the state."* It deals mainly with control of "waste and process discharges from future development." The amendment does not affect any of the City's goal 6 implementation measures. These implementation measures, in the Development Code and the Comprehensive Plan, remain in effect. Based on this, the City Commission Finds that the amendments are consistent with Statewide Planning Goal 6.

#### **Statewide Planning Goal 7, Areas Subject to Natural Hazards**

Goal 7 is to *"to protect people and property from natural hazards."* The City's goal 7 implementation measures are not changed by the amendment. The Flood Hazard Overlay Zone and the Soil Hazard Overlay zone are two of the City's principal goal 7 implementation tools. These are unchanged by the amendment. Those areas subject to goal 7 are still subject to the City's goal 7 implementation measures. Based on this, the City Commission finds the amendments do not conflict with Statewide Planning Goal 7.

#### **Statewide Planning Goal 8, Recreational Needs**

Goal 8 is *"to satisfy the recreational needs of the citizens of the state and visitors and, where appropriate, to provide for the siting of necessary recreational facilities including destination resorts."* The City's goal 8 needs are met by lands that are zoned primarily for recreational purposes. The amendment does not change this. The amendment does not alter the City's approach to meeting its goal 8 obligations, or any goal 8 implementation measures. None of the City's Goal 8 Comprehensive Plan policies are changed by the amendment. Based on this, the City Commission finds that the amendment is consistent with Statewide Planning Goal 8.

#### **Statewide Planning Goal 9, Economic Development**

Goal 9 is *"to provide adequate opportunities throughout the state for a variety of economic activities vital to the health, welfare, and prosperity of Oregon's citizens."* The amendment has no impact on the City's ability to meet its goal 9 obligations. The amendment does not reduce the City's inventory of buildable commercial or industrial lands. The amendment identifies in which zoning districts Homestay Lodging and Vacation Rental Dwellings are permitted or conditional uses. The proposal allows for the collection of Transient Room Tax, and will provide an avenue to legalize Homestay Lodging rentals that exist within the City. Based on this, the City Commission finds the amendment consistent with Statewide Planning Goal 9.

### **Statewide Planning Goal 10, Housing**

Goal 10 is *“to provide for the housing needs of citizens of the state.”* The goal requires cities to assess future need for various housing types and to plan and zone sufficient buildable land to meet those projected needs. The amendment has limited impact on land available for housing in Warrenton; and it does not change the substantive or procedural requirements for approval of new residential development; nor does it alter the mix of housing types allowed in the City. Costs to construct housing on the north coast are very high. This includes new single-family and accessory dwellings. The city continues to find unpermitted vacation rental activity, and is attempting to assist in legalizing those properties that meet code, and clarifying code requirements to eliminate those vacation rentals that are not permitted. The City will continue to monitor the impacts on housing in the area with the amendment to this code, and may consider a future cap on short term rental properties in order to maintain housing supply. Allowing Vacation Rental Dwellings in existing single-family homes in commercial zones has a smaller impact on housing than in residential zones, as those structures are permitted to change over to commercial uses now as well as under the code amendments. Short term rentals of any type are not a housing type, but rather an economic development and lodging use. Based on this, the City Commission finds the amendments consistent with Statewide Planning Goal 10.

### **Statewide Planning Goal 11, Public Facilities and Services**

Goal 11 is *“to plan and develop a timely, orderly and efficient arrangement of public facilities and services to serve as a framework for urban and rural development.”* The amendment does not change any of the City’s goal 11 implementation measures. The supply of developable lands, and the capacity of public facilities needed to serve those lands, are unchanged by the amendment. The amendment has no impact on City policies regarding the expansion and financing of public facilities. Based on this, the City Commission finds the amendment consistent with Statewide Planning Goal 11.

### **Statewide Planning Goal 12, Transportation**

Goal 12 is *“to provide and encourage a safe, convenient and economic transportation system.”* The City’s goal 12 implementation measures are unaffected by the amendment. Warrenton’s existing transportation infrastructure and the City’s plans for future expansion of transportation facilities are unchanged by the amendment. Current and likely future transportation demand is not affected by the amendments. Based on this, the City Commission finds the development code amendment consistent with Statewide Planning Goal 12.

### **Statewide Planning Goal 13, Energy**

Goal 13 is simply *“to conserve energy”*. The City’s goal 13 implementation measures are unchanged by the amendment. Based on this, the City Commission finds that the amendment is consistent with Statewide Planning Goal 13.

#### **Statewide Goal 14, Urbanization**

Goal 14 is *“to provide for an orderly and efficient transition from rural to urban land use, to accommodate urban population and urban employment inside urban growth boundaries, to ensure efficient use of land, and to provide for livable communities.”* The amendment does not conflict with this goal: it corrects missing code references withing permitted uses and conditional uses. The amendment does not alter the UGB. None of the City’s goal 14 implementation measures are affected by the amendment. Based on this, the City Commission finds the amendments consistent with Statewide Planning Goal 14.

#### **Statewide Planning Goal 15, Willamette River Greenway**

Not applicable

#### **Statewide Planning Goal 16, Estuarine Resources**

Goal 16 is *“to recognize and protect the unique environmental, economic, and social values of each estuary and associated wetlands; and to protect, maintain, where appropriate develop, and where appropriate restore the long-term environmental, economic, and social values, diversity and benefits of Oregon’s estuaries.”* The City’s primary goal 16 implementation measures are the estuarine resources element of its comprehensive plan; the development code’s Aquatic Natural, Aquatic Conservation, and Aquatic Development zones; and the development code’s Columbia River Estuary Shoreland and Aquatic Area Development Standards. These implementation measures are unaffected by the amendment. Based on this, the City Commission finds the amendment consistent with Statewide Planning Goal 16.

#### **Statewide Planning Goal 17, Coastal Shorelands**

Goal 17 aims *“to conserve, protect, where appropriate, develop and where appropriate restore the resources and benefits of all coastal shorelands, recognizing their value for protection and maintenance of water quality, fish and wildlife habitat, water-dependent uses, economic resources and recreation and aesthetics.”* The City implements goal 17 primarily through the Coastal Shorelands element of its comprehensive plan; and through the development code’s Coastal Lake and Freshwater Wetlands Zone, and Water-Dependent Industrial Shorelands Zone. The amendment does not change any of these implementation measures. Based on this, the City Commission finds that the amendment is consistent with Statewide Planning Goal 17.

#### **Statewide Planning Goal 18, Beaches and Dunes**

Goal 18 is: *“To conserve, protect, where appropriate develop, and where appropriate restore the resources and benefits of coastal beach and dune areas; and to reduce the hazard to human life and property from natural or man-induced actions associated with these areas.”* The City’s basic implementation measures for goal 18 are the Comprehensive plan’s beaches and dunes element, and the development code’s Beach and Dune Overlay District. The amendment does not change any of these implementation measures, or the City’s overall goal 18 planning strategy. Based on this, the City Commission finds that the amendment is consistent with Statewide Planning Goal 18.

**Statewide Planning Goal 19, Ocean Resources**

Not applicable

**Ordinance 1248**  
**Introduced by All Commissioners**

**AN ORDINANCE AMENDING WARRENTON MUNICIPAL CODE TITLE 16,  
DEVELOPMENT CODE, DIVISION 1, CHAPTER 16.12 DEFINITIONS; DIVISION 2,  
LAND USE DISTRICTS, CHAPTERS: 16.24, 16.28, 16.32, 16.36, 16.40, 16.44, 16.56; AND  
DIVISION 3, CHAPTER 16.180**

**WHEREAS**, the City Commission finds it appropriate to amend the Development Code's reference to Homestay Lodging and Vacation Rental Dwellings to meet the City's needs; and

**WHEREAS**, the City of Warrenton is best served by land use decisions that are clear in their intent within the Development Code; and

**WHEREAS**, the City Commission conducted a public hearing on this amendment on April 27, 2021, to receive public testimony and to consider the Planning Commission's recommendation;

**NOW, THEREFORE**, the City of Warrenton ordains as follows:

**Section 1.** Amend Warrenton Municipal Code Division 1, Introduction, Chapter 16.12 Definitions to insert the following definitions as written:

[new language; ~~deleted language~~]

**Homestay Lodging.** A short-term rental in an owner-occupied, single-family detached dwelling unit using up to five bedrooms, including bedrooms in accessory dwellings.

**Vacation Rental Dwelling.** A single-family dwelling or accessory dwelling that is nonowner occupied and is rented for terms of less than 30 days.

**Section 2.** Amend Warrenton Municipal Code Division 2, Land Use Districts (various chapters) to read as follows:

[new language; ~~deleted language~~]

16.24.020 Permitted Uses.

P. Homestay Lodging subject to the standards in Chapter 8.24.

16.28.020 Permitted Uses.

Q. Homestay Lodging subject to the standards in Chapter 8.24.

16.32.020 Permitted Uses.

R. Homestay Lodging subject to the standards in Chapter 8.24.

16.36.020 Permitted Uses.

R. Homestay Lodging subject to the standards in Chapter 8.24.

16.40.020 Permitted Uses.

A. Only the following uses and their accessory uses are permitted along Highway 101, SE Marlin, SE Ensign Drive, SE Discovery Lane, and SE Dolphin Avenues and shall comply with the above noted sections as well as Chapter 16.132:

21. Homestay Lodging subject to the standards in Chapter 8.24.

22. Vacation Rental Dwelling subject to the Safety Regulations in Chapter 8.24.030.

~~21-23.~~ Similar uses as those stated above.

B. For all other C-1 zoned areas within the City limits of Warrenton, the following uses and their accessory uses are permitted and shall comply with the above noted sections:

24. Homestay Lodging subject to the standards in Chapter 8.24.

25. Vacation Rental Dwelling subject to the Safety Regulations in Chapter 8.24.030.

~~24-26.~~ Similar uses as those stated in this section. (*retain ordinance references*)

16.44.020 Permitted Use

A. Residential.

6. Homestay Lodging subject to the standards in Chapter 8.24.

~~6-7.~~ Similar uses as those listed in this section.

16.44.030 Conditional Uses.

H. Vacation Rental Dwelling subject to the Safety Regulations in Chapter 8.24.030.

~~H-I.~~ Similar uses as those listed in this section. (*retain ordinance references*)

16.56.030 Conditional Uses.

M. Vacation Rental Dwelling subject to the Safety Regulations in Chapter 8.24.030.

~~M-N.~~ Similar uses as those listed in this section.

**Section 3.** Amend Warrenton Municipal Code Division 3, Design Standards, Chapter 16.180 Accessory Structure, Accessory Dwelling, Garage, and Carport Design Standards, Section 16.180.040 to read as follows:

[new language; ~~deleted language~~]

An accessory dwelling is a small, secondary housing unit located on a legal lot with an established single-family residence. Accessory dwellings are typically the size of a studio apartment. The additional unit can be a detached cottage, a unit attached to a garage, or in a portion of an existing house. Accessory dwellings provide cost-effective and independent living spaces for family members, such as in-laws, retired parents, etc. Accessory dwellings can also

provide semi-independent living spaces for physically or mentally disabled family members requiring partial supervision or assistance with activities of daily living. ~~Accessory dwellings are never suited for rental dwellings and use of an accessory dwelling as a rental or income-producing unit is strictly prohibited and is subject to enforcement and penalties as prescribed by this Code.~~ Accessory dwellings may be rented long term as a permitted use. Accessory dwellings may be rented as part of a permitted Homestay Lodging use so long as the main structure of the property is owner-occupied. The housing density standard of residential zones does not apply to accessory dwellings, due to the small size and low occupancy level of the use. The following standards are intended to control the size and number of accessory dwellings on individual lots, so as to promote compatibility with adjacent land uses. Accessory structures shall comply with the following standards:

C. ~~Rental Unit Prohibited.~~ ~~Accessory dwellings are never appropriate for use as a rental unit or other income producing unit.~~ Accessory dwellings may be rented long term as a permitted use. Accessory dwellings may be rented as part of a permitted Homestay Lodging use so long as the main structure of the property is owner-occupied. Accessory dwellings shall not be used as servants' quarters or as lodging (temporary or permanent) for housekeepers, gardeners, etc. Use of an accessory dwelling for purposes other than what is expressly permitted in this section is strictly prohibited and shall be subject to the enforcement and penalty provisions of Chapter 16.16.

**Section 4.** This Ordinance shall take full force and effect 30 days upon its adoption by the Commission of the City of Warrenton.

**First Reading: April 27, 2021**

**Second Reading: May 11, 2021**

**ADOPTED by the City Commission of the City of Warrenton, Oregon this May 11, 2021.**

Approved

---

Henry A. Balensifer III, Mayor

Attest

---

Dawne Shaw, City Recorder

**Ordinance 1250**  
**Introduced by All Commissioners**

**AN ORDINANCE AMENDING WARRENTON MUNICIPAL CODE TITLE 8, HEALTH  
AND SAFETY, CHAPTER 24 HOMESTAY LODGING SAFETY STADARDS**

**WHEREAS**, the City Commission finds it appropriate to amend the Warrenton Municipal Code to update Safety Standard for Homestay Lodging and Vacation Rentals to meet the City's needs; and

**WHEREAS**, the City of Warrenton is best served by land use decisions that mitigate detrimental impacts to surrounding property owners; and

**WHEREAS**, the City Commission conducted a public hearing on this amendment on April 27, 2021, to receive public testimony and to consider the Planning Commission's recommendation;

**NOW, THEREFORE**, the City of Warrenton ordains as follows:

**Section 1.** Amend Warrenton Municipal Code Section 8.24.030, to read as follows:

[new language; deleted language]

8.24.030 Safety regulations.

12. Provide one off-street parking space per guest bedroom. The approved off-street parking space must remain available for renters. A parking diagram of the approved parking spaces must be provided to renters and be available in a prominent location within the dwelling. Parking stalls shall meet the minimum standards of Section 16.128.030.

17. 24-hour Representative: The vacation rental owner and designated representative's name, physical address, email address and phone number must be provided to the City upon permit application and renewal. The information shall be kept current at all times. The owner or representative shall be available by phone (24 hours a day, seven days a week) to ensure a response to complaints regarding emergencies and the condition, operation, or conduct of the occupants. A 24-hour representative must be able to physically respond to the vacation rental site within 30 minutes, and if requested they must respond. If there is a change in the designated representative the property owner must submit to the City the name of the new representative.

**Section 2.** This Ordinance shall take full force and effect 30 days upon its adoption by the Commission of the City of Warrenton.

**First Reading: April 27, 2021**

**Second Reading: May 11, 2021**

**ADOPTED by the City Commission of the City of Warrenton, Oregon this May 11, 2021.**

Approved

---

Henry A. Balensifer III, Mayor

Attest

---

Dawne Shaw, City Recorder

**GUIDANCE ON IMPLEMENTING  
THE ACCESSORY DWELLING UNITS (ADU) REQUIREMENT  
UNDER OREGON SENATE BILL 1051  
UPDATED TO INCLUDE HB 2001 (2019)**



*M. Klepinger's backyard detached ADU, Richmond neighborhood, Portland, OR.  
(Photo courtesy of Ellen Bassett and [accessorydwellings.org](http://accessorydwellings.org).)*

**OREGON DEPARTMENT OF LAND CONSERVATION AND DEVELOPMENT**

**MARCH 2018, updated SEPTEMBER 2019**



## Introduction

As housing prices in Oregon go up, outpacing employment and wage growth, the availability of affordable housing is decreasing in cities throughout the state. While Oregon's population continues to expand, the supply of housing, already impacted by less building during the recession, has not kept up. To address the lack of housing supply, House Speaker Tina Kotek introduced House Bill (HB) 2007 during the 2017 legislative session to, as she stated, "remove barriers to development." Through the legislative process, legislators placed much of the content of HB 2007 into Senate Bill (SB) 1051, which then passed, and was signed into law by Governor Brown on August 15, 2017 (codified in amendments to Oregon Revised Statute 197.312). In addition, a scrivener's error<sup>1</sup> was corrected through the passage of HB 4031 in 2018.

Among the provisions of SB 1051 and HB 4031 is the requirement that cities and counties of a certain population allow accessory dwelling units (ADUs) as described below:

- a) *A city with a population greater than 2,500 or a county with a population greater than 15,000 shall allow in areas within the urban growth boundary that are zoned for detached single-family dwellings the development of at least one accessory dwelling unit for each detached single-family dwelling, subject to reasonable local regulations relating to siting and design.*
- b) *As used in this subsection, "accessory dwelling unit" means an interior, attached or detached residential structure that is used in connection with or that is accessory to a single-family dwelling.*

This requirement became effective on July 1, 2018 and subject cities and counties must now accept applications for ADUs inside urban growth boundaries (UGBs).

On August 8, 2019, Governor Brown signed HB 2001, which established that off-street parking and owner-occupancy requirements are not "reasonable local regulations relating to siting and design." This means that, even if a local development code requires off-street parking and owner-occupancy, as of January 1, 2020, local jurisdictions may not mandate off-street parking spaces for ADUs nor require a property owner to live in either a primary or

---

<sup>1</sup> The scrivener's error in SB 1051 removed the words "within the urban growth boundary." HB 4031 added the words into statute and thus limited the siting of ADUs to within UGBs. As a result, land within a city with a population greater than 2,500 but that is not within a UGB is not required by this law to be zoned to allow accessory dwelling units. For counties with a population greater than 15,000, only those unincorporated areas within a UGB are required by this law to be zoned to allow accessory dwelling units.

accessory dwelling. The law provides an exception for ADUs that are used as vacation rentals, which may be mandated to provide off-street parking or have owner-occupancy requirements.

Some local governments in Oregon already have ADU regulations that meet the requirements of SB 1051 and HB 2001, however, many do not. Still others have regulations that, given the overall legislative direction to encourage the construction of ADUs to meet the housing needs of Oregon's cities, are not "reasonable." The Oregon Department of Land Conservation and Development (DLCD) is issuing this guidance and model code language to help local governments comply with the legislation. The model code language is included at the end of this document.

**Guidance by Topic**

The purpose of the following guidance is to help cities and counties implement the ADU requirement in a manner that meets the letter and spirit of the law: to create more housing in Oregon by removing barriers to development.

*Number of Units*

The law requires subject cities and counties to allow "at least one accessory dwelling unit for each detached single-family dwelling." While local governments must allow one ADU where required, DLCD encourages them to consider allowing two units. For example, a city or county could allow one detached ADU and allow another as an attached or interior unit (such as a basement conversion). Because ADUs blend in well with single-family neighborhoods, allowing two units can help increase housing supply while not having a significant visual impact. Vancouver, BC is a successful example of such an approach.

*Siting Standards*

In order to simplify standards and not create barriers to development of ADUs, DLCD recommends applying the same or less restrictive development standards to ADUs as those for other accessory buildings. Typically that would mean that an ADU could be developed on any legal lot or parcel as long as it met the required setbacks and lot coverage limits; local governments should not mandate a minimum lot size for ADUs. So that lot coverage requirements do not preclude ADUs from being built on smaller lots, local governments should review their lot coverage standards to make sure they don't create a barrier to development. Additionally, some jurisdictions allow greater lot coverage for two ADUs. To address storm water concerns, consider limits to impermeable surfaces rather than simply coverage by structures.

Any legal nonconforming structure (such as a house or outbuilding

that doesn't meet current setback requirements) should be allowed to contain, or be converted to, an ADU as long as the development does not increase the nonconformity and it meets building and fire code.

#### *Design Standards*

Any design standards required of ADUs must be clear and objective (ORS 197.307[4]). Clear and objective standards do not contain words like "compatible" or "character." With the exception of ADUs that are in historic districts and must follow the historic district regulations, DLCD does not recommend any special design standards for ADUs. Requirements that ADUs match the materials, roof pitch, windows, etc. of the primary dwelling can create additional barriers to development and sometimes backfire if the design and materials of the proposed ADU would have been of superior quality to those of the primary dwelling, had they been allowed. Other standards, such as those that regulate where entrances can be located or require porches and covered entrances, can impose logistical and financial barriers to ADU construction.

#### *Public Utilities*

Development codes that require ADUs to have separate sewer and water connections create barriers to building ADUs. In some cases, a property owner may want to provide separate connections, but in other cases doing so may be prohibitively expensive.

#### *System Development Charges (SDCs)*

Local governments should consider revising their SDC ordinances to match the true impact of ADUs in order to remove barriers to their development. In fact, HB 2001, passed by the Oregon Legislature in 2019, requires local governments to consider ways to increase the affordability of middle housing types through ordinances and policies, including waiving or deferring system development charges. ADUs are not a middle housing type, but if a local government is reviewing its SDCs for middle housing, that would be a good time to review ADU SDCs as well. ADUs are generally able to house fewer people than average single-family dwellings, so their fiscal impact would be expected to be less than a single-family dwelling. Accordingly, it makes sense that they should be charged lower SDCs than primary detached single-family dwellings. Waiving SDCs for ADUs has been used by some jurisdictions to stimulate the production of more housing units.

This page intentionally left blank.

## Accessory Dwellings (model code)

**Note:** ORS 197.312 requires that at least one accessory dwelling be allowed per detached single-family dwelling in every zone within an urban growth boundary that allows detached single-family dwellings. The statute does not allow local jurisdictions to include off-street parking nor owner-occupancy requirements. Accessory dwellings are an economical way to provide additional housing choices, particularly in communities with high land prices or a lack of investment in affordable housing. They provide an opportunity to increase housing supply in developed neighborhoods and can blend in well with single-family detached dwellings. Requirements that accessory dwellings have separate connections to and pay system development charges for water and sewer services can pose barriers to development. Concerns about neighborhood compatibility and other factors should be considered and balanced against the need to address Oregon's housing shortage by removing barriers to development.

The model development code language below provides recommended language for accessory dwellings. The italicized sections in brackets indicate options to be selected or suggested numerical standards that communities can adjust to meet their needs. Local housing providers should be consulted when drafting standards for accessory dwellings, and the following standards should be tailored to fit the needs of your community.

Accessory dwellings, where allowed, are subject to review and approval through a Type I procedure[, pursuant to Section \_\_\_\_\_,] and shall conform to all of the following standards:

- [**A. One Unit.** *A maximum of one Accessory Dwelling is allowed per legal single-family dwelling. The unit may be a detached building, in a portion of a detached accessory building (e.g., above a garage or workshop), or a unit attached or interior to the primary dwelling (e.g., an addition or the conversion of an existing floor).*  
/  
**A. Two Units.** *A maximum of two Accessory Dwellings are allowed per legal single-family dwelling. One unit must be a detached Accessory Dwelling, or in a portion of a detached accessory building (e.g., above a garage or workshop), and one unit must be attached or interior to the primary dwelling (e.g., an addition or the conversion of an existing floor).]*

### **B. Floor Area.**

1. A detached Accessory Dwelling shall not exceed [800-900] square feet of floor area, or [75-85] percent of the primary dwelling's floor area, whichever is smaller.
2. An attached or interior Accessory Dwelling shall not exceed [800-900] square feet of floor area, or [75-85] percent of the primary dwelling's floor area, whichever is smaller. However, Accessory Dwellings that result from the conversion of a level or floor (e.g., basement, attic, or second story) of the primary dwelling may occupy the entire level or floor, even if the floor area of the Accessory Dwelling would be more than [800-900] square feet.

**C. Other Development Standards.** Accessory Dwellings shall meet all other development standards (e.g., height, setbacks, lot coverage, etc.) for buildings in the zoning district, except that:

1. Conversion of an existing legal non-conforming structure to an Accessory Dwelling is allowed, provided that the conversion does not increase the non-conformity;

2. No off-street parking is required for an Accessory Dwelling;
3. Properties with two Accessory Dwellings are allowed [10-20%] greater lot coverage than that allowed by the zone in which they are located; and
4. Accessory dwellings are not included in density calculations.

---

**Definition** (This should be included in the “definitions” section of the zoning ordinance. It matches the definition for Accessory Dwelling found in ORS 197.312)

**Accessory Dwelling** – An interior, attached, or detached residential structure that is used in connection with, or that is accessory to, a single-family dwelling.



P.O. BOX 250 ■ WARRENTON, OR 97146-0250 ■ OFFICE: 503.861.2233 ■ FAX: 503.861.2351

---

April 27, 2021

To: Warrenton City Commission

From: Scott Hess, Community Development Director

Re: Amendment to Warrenton Municipal Code (WMC) Title 16 Development Code to update Marijuana businesses in General Commercial (C-1) and General Industrial (I-1) to Conditional Uses as opposed to Permitted Uses. (File DCR-21-2 – Ordinance 1249)

**Summary:** These proposed development code amendments make two changes to Title 16, Division 2: first it moves Medical marijuana dispensaries and recreational marijuana retail outlets in General Commercial (C-1) from Permitted Use to Conditional Use, second it moves Recreational marijuana production, recreational marijuana processing, or recreational marijuana wholesale activities in General Industrial (I-1) from Permitted Use to Conditional Use. The Code language referenced in Ordinance 1249 also cleans up two small existing typos, but does not substantively amend the additional development standards that marijuana businesses are required to abide by. These changes are being requested in order to provide additional review and opportunity to mitigate impacts these businesses may have on their surrounding uses.

The Planning Commission held a public hearing on the proposed code amendments at the March 11, 2021 Planning Commission meeting. Staff worked with legal counsel on an appropriate notice methodology, and determined that a direct mailing to all property owners of C-1 and I-1 land, east of the 101, provided notice to all affected property owners. Those mailers went out on February 18, 2021. Staff received one written response from the Moore family that has been included in this item.

**Proposed Amendments: General Commercial (C-1)**

The current Code reads as follows:

16.40.020 Permitted Uses.

19. Medical marijuana dispensaries and recreational marijuana retail outlets licensed by the State of Oregon and subject to Section 16.040.060.I.

Staff recommends amending the language to place this use in Conditional Uses, and also to correct a small type in the referenced Code to Other Applicable Standards. The revised language is below:

16.40.030 Conditional Uses.

7. Medical marijuana dispensaries and recreational marijuana retail outlets licensed by the State of Oregon and subject to Section 16.40.060.I.

No changes are recommended for the “Other Applicable Standards” section below:

16.40.060 Other Applicable Standards.

- I. State licensed medical marijuana dispensaries and recreational marijuana retail outlets shall be located only east of Highway 101 and at least 1,000 feet from any public or private school, church, public park, or child care center, and operate exclusively as a single building occupant or with other licensed medical marijuana dispensaries or recreational marijuana retail outlets. (Ord. 1196-A § 2, 2015)

**Proposed Amendments: General Industrial (I-1)**

The current Code reads as follows:

16.60.020 Permitted Uses.

- T. Recreational marijuana production, recreational marijuana processing, or recreational marijuana wholesale activities, subject to Section 16.60.040.N.

Staff recommends amending the language to place use in Conditional Uses. The revised language is below:

16.60.030 Conditional Uses.

- D. Recreational marijuana production, recreational marijuana processing, or recreational marijuana wholesale activities, subject to Section 16.60.040.N.

To correct a small type, staff recommends updating the Development Standards section. This proposed change does not substantively change the intent of the code, but rather makes it easier to read and understand.

The current Code reads as follows:

16.60.040 Development Standards.

- N. Recreational marijuana production, recreational marijuana processing, and recreational marijuana wholesale activities shall be located only east of Highway 101 and at least 1,000 feet from any public or private school, church, public park

or child care center, and shall exclusively as a single building occupant or with other licensed medical marijuana dispensaries or recreational marijuana retail outlets. (Ord. 1196-A § 4, 2015)

Staff recommends amending the language to correct a typo as follows:

16.60.040 Development Standards.

N. Recreational marijuana production, recreational marijuana processing, and recreational marijuana wholesale activities shall be located only east of Highway 101 and at least 1,000 feet from any public or private school, church, public park or child care center, and shall operate exclusively as a single building occupant or with other licensed medical marijuana dispensaries or recreational marijuana retail outlets. (Ord. 1196-A § 4, 2015)

**Public Process, Procedures & Public Notice:** The Community Development Director has the authority to initiate a text amendment according to WMC 16.208.070.D, General Provisions.

This proposal is being reviewed pursuant to WMC 16.208.060, Type IV Procedure (Legislative and Map Amendments). Also applicable are the statewide planning goals, and the Comprehensive Plan. Findings for the Comprehensive Plan and Statewide Planning Goals are included in this staff report.

Notice of the Planning Commission public hearing was sent to DLCD on February 4, 2020, letters were mailed to affected property owners on February 19, 2021, and notice was published in *The Daily Astorian* on February 27, 2021 as required prior to the March 11, 2021 Planning Commission meeting. As noted above, one written comment was received as of the date of this staff report, and was included for the Planning Commission's consideration.

The Planning Commission recommended approval of these Development Code amendments at their March 11, 2021 meeting. The City Commission will now consider the Planning Commission's recommendation, conduct a public hearing, and make a final decision on the proposed amendment.

**Recommendation:** Staff recommends the City Commission hold a public hearing for the first reading of Ordinance 1249. Staff recommends approval of the Ordinance Amendments as drafted. The City Commission may take the following action: Approve as presented, Approve with amendments, or Deny. A recommended motion is below:

*"I motion to approve DCR 21-2, Ordinance 1249, to amend Warrenton Municipal Code Title 16 Development Code updating Marijuana businesses in General Commercial (C-1) and General Industrial (I-1) to Conditional Uses as opposed to Permitted Uses as presented in the Staff Report and Draft Findings."*

**Attachments:**

- Findings, DCR 21-2 - Ordinance 1249
- Draft Ordinance 1249 – First Reading
- Gary and Barbara Moore letter dated 3-1-2021

Approved by City Manager.

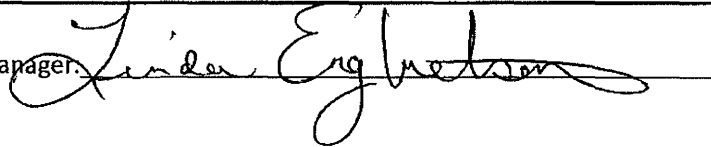
A handwritten signature in black ink, reading "Zander Engelson", written over a horizontal line.

All supporting documentation, i.e., maps, exhibits, etc., must be attached to this memorandum.



## Findings, DCR 21-2 - Ordinance 1249

### Comprehensive Plan, Article 10 Procedures

#### SECTION 10.100 FINDINGS

##### Section 10.200 Goals

*Establish a comprehensive planning process which benefits the public as a whole by ensuring the opportunity for local citizens to be involved during all phases of the process, requiring an adequate factual basis for decisions and actions, achieving a desirable level of coordination and consistency with other governmental bodies, and providing a suitable balance between stability and change. (Comprehensive Plan Section 10.200, Procedures, Goals)*

This goal is implemented, in part, through the various types of decision-making procedures described in the Development Code. The amendment to move Marijuana Businesses from Permitted Uses to Conditional Uses does not conflict with this policy because it does not reduce or curtail opportunities for citizen involvement in the planning process; nor does the amendment compromise the requirement for an adequate factual basis for decisions and actions; nor does the amendment change the balance between stability and change. In many ways it improves the public's ability to engage with the decision-making process by requiring the notice of Type III Conditional Uses.

#### SECTION 10.300 POLICIES

##### Section 10.310 Plan Review and Update

*Effective review and updating of the Comprehensive Plan will be carried out through extensive involvement of the Planning Commission. (Comprehensive Plan Section 10.310, Procedures, Policy 1)*

Policy 1 assures that the Planning Commission is involved in comprehensive plan amendments. The proposed amendment does not reduce the Planning Commission's role; nor does it change the way the City develops and reviews comprehensive plan amendments. Comprehensive plan amendments are handled under a Type IV procedure. This amendment affects only Type III decisions. Based on this, the City Commission finds the amendment consistent with policy 1.

*The City will undertake a major review of its Comprehensive Plan in accordance with the State mandated periodic review schedule. The City will make other revisions to the Comprehensive Plan as necessary to address local needs and concerns. (Comprehensive Plan Section 10.310, Procedures, Policy 2)*

The amendment does not alter the City's ability to consider Comprehensive Plan amendments at any time. Note that the State-mandated periodic review schedule described in policy 2 is no longer in effect. Comprehensive Plan amendments are handled under a Type IV procedure. This amendment affects only Type III decisions. Based on this, the City Commission finds the amendment consistent with this policy.

*All Comprehensive Plan amendments shall comply with the Statewide Planning Goals and will be supported by adequate evidence indicating the desirability of the proposed revisions. The desirability of changes in the intent or boundaries of land and water use areas, as shown on the respective maps, will be determined in part by (a) the expected impact on the ability of the Plan to help satisfy land and water use needs; (b) the improvements to transportation facilities and community facilities and services, if any, necessary to accommodate the change; and (c) the physical development limitation and other natural feature characteristics of the areas involved. (Comprehensive Plan Section 10.310, Procedures, Policy 3)*

Policy 3 requires that the amendment complies with the applicable statewide planning goals. These are addressed below in these findings.

Policy 3 also requires evidence indicating the desirability of the proposed revisions. The amendment will require all marijuana businesses to go through a Conditional Use Permit procedure. This amendment will allow the Planning Commission to fully consider any detrimental effects these businesses may have on Warrenton property owners, and will allow a process to effectively condition approvals to mitigate concerns.

Policy 3 also addresses map amendments. This amendment is to the text of the zoning ordinance, and has no impact on amendments to the zoning map or comprehensive plan map.

For these reasons, the City Commission finds the amendment consistent with policy 3.

*Amendments to the Comprehensive Plan text or map may be initiated by the City Commission, Planning Commission, Community Development Director, any City resident or any person or organization owning real property in the City. The person proposing the amendments will be responsible for providing justification for the revisions, and will also be responsible for providing a form of notice and for the text of any exception language, should such be necessary to meet Statewide Planning Goals. (Comprehensive Plan Section 10.310, Procedures, Policy 4)*

This amendment was initiated by the Community Development Director at the direction of the Planning Commission. The justification for the revision is that it provides more opportunity to mitigate detrimental impacts from marijuana businesses. The language in policy 4 referring to exception language is not relevant to this amendment. Based on this, the City Commission finds the amendment consistent with policy 4.

*The Planning Commission and the City Commission shall hold public hearings on proposed amendments to the Comprehensive Plan or map. Notice of public hearings will be given in accordance with Development Code requirements. (Comprehensive Plan Section 10.310, Procedures, Policy 5)*

The amendment does not alter the notice and hearing requirements in policy 4. The adoption procedure for DCR 21-2 followed the Development Code's applicable Type IV requirements. The amendment affects only Type III conditional use permit decisions. Based on this, the City Commission finds the amendment consistent with policy 5.

*For purposes of reviewing and updating the Comprehensive Plan, the Planning Commission will be the officially recognized committee for citizen involvement. It will be appointed in an open and public manner and its membership shall be representative of a broad range of geographical, cultural and economic elements of the population in the Warrenton area. Adequate resources will be allocated for its activities and other citizen involvement efforts. (Comprehensive Plan Section 10.310, Procedures, Policy 6)*

The amendment does not change the Planning Commission's role as the committee for citizen involvement in Comprehensive Plan reviews and updates; nor does the amendment alter the method for appointing Planning Commissioners. The City provides adequate financial resources for citizen involvement efforts through its budget process; the amendment does not change this. For these reasons, the City Commission finds the amendment consistent with policy 6.

*The Planning Commission and City staff will provide the general public with an opportunity to be involved in inventory work, plan revisions and plan implementation. Efforts will be undertaken to respond to citizen suggestions and make technical information and minutes of meetings available to the general public. (Comprehensive Plan Section 10.310, Procedures, Policy 7)*

The amendment does not reduce opportunities for the public to be involved in inventory work, comprehensive plan revisions, and plan implementation. The City makes agendas, staff reports, and Planning Commission minutes available on its website, and at City Hall. The amendment does not alter the availability of technical information and meeting minutes. Based on this, the City Commission finds that the amendment does not conflict with policy 7.

*When reviewing and updating the Comprehensive Plan, the City will attempt to (a) give ample consideration to the comments and concerns of other governmental bodies; (b) achieve consistency with their policies to the extent appropriate; and (c) avoid*

*unnecessary overlapping responsibilities. Affected special districts and appropriate local, regional, state and federal agencies will be notified by mail of public hearings on Comprehensive Plan amendments. (Comprehensive Plan Section 10.310, Procedures, Policy 8)*

This policy addresses Comprehensive Plan reviews and updates. Reviews are work session items. Updates are considered under a Type IV procedure. The amendment addresses Type III conditional use permit decisions. The policy is not applicable to the proposed amendment.

### **Section 10.320 Plan Implementation**

*Implementation will occur in a manner which makes possible meaningful participation by local citizens and interested governmental bodies; consistency between the Plan and implementation measures intended to fulfill Plan objectives; and periodic review and update of these controls. (Comprehensive Plan Section 10.320, Plan Implementation, Policy 1)*

The amendment does not detract from the policy of ensuring meaningful participation in the implementation of the Comprehensive Plan. The amendment does not alter any other implementation measures related to citizen participation.

The amendment does not create an inconsistency between the Development Code and the Comprehensive Plan. As shown by these findings, the amendment does not conflict with applicable Comprehensive Plan policies.

The amendment does not interfere with the City's effort to review and update the Comprehensive Plan and Development Code. These updates are considered under a Type IV procedure; the amendment modifies the Development Code's Type III conditional use permit decisions.

For these reasons, the City Commission finds the amendment consistent with Plan Implementation policy 1.

*Major actions undertaken to implement the Comprehensive Plan shall take place in a well-publicized, open atmosphere. The Planning Commission, general public and interested governmental bodies will be given an opportunity to comment on these actions before they are carried out. (Comprehensive Plan Section 10.320, Plan Implementation, Policy 2)*

The Comprehensive Plan is implemented through the Development Code and the Zoning Map, so *major actions to implement the comprehensive plan* include development code amendments, such as this one. This amendment and the hearings before the Planning Commission have been well-publicized by notices mailed directly to affected property owners, posting in The Daily Astorian, and on the City's website. Additionally, the amendment has been

posted on the Oregon Department of Land Conservation and Development's website. The general public and interested governmental bodies had the opportunity to comment on the amendment. The Planning Commission's recommendation was received by the City Commission at a public hearing on April 27, 2021. The City Commission finds that the amendment's adoption process was consistent with the procedural requirements of Plan Implementation policy 2, as implemented through the City's Development Code. The City Commission further finds that the amendment is consistent with Policy 2 because it does not alter the requirements of policy 2: the amendment affects only Type III matters, not Development Code or Zoning Map amendments, which are considered under Type IV procedures.

*Provisions of the zoning ordinance, subdivision and partitioning regulations and other land and water use controls used to implement the Plan shall be consistent with the Plan. This does not mean, however, that these provisions have to be specifically authorized by the Plan or cannot be more detailed than those in the Plan.*

(Comprehensive Plan Section 10.320, Plan Implementation, Policy 3)

The consistency requirement in policy 3 is not violated by the amendment because the Type III conditional use permit decision-making process exists within the development code, and nowhere else in the City's planning documents. For this reason, the City Commission finds the amendment consistent with Plan Implementation policy 3.

*Land and water use controls used to implement the Plan will be periodically reviewed and updated. Before changes in the regulations are adopted, there will be at least one public hearing on the proposal and adequate public notice of every hearing.*

(Comprehensive Plan Section 10.320, Plan Implementation, Policy 4)

The *land and water use controls* that implement the Comprehensive Plan are the Development Code and the Zoning Map. The Planning Commission considered this Development Code amendment at a public hearing on March 11, 2021. The hearing was noticed via mail to affected property owners, advertised in The Daily Astorian on February 27, 2021, and on the City's website. The amendment does not alter the hearing or public notice requirements for Development Code or Zoning Map amendments. As noted elsewhere in these findings, the amendment has no impact on Development Code or Zoning Map amendments, which are heard under a Type IV procedure, because the amendment affects the Type III land use decisions for conditional uses only. Based on this, the City Commission finds the amendment consistent with the requirements of Plan Implementation policy 4.

#### **Statewide Planning Goal 1, Citizen Involvement**

Goal 1 is: *To develop a citizen involvement program that ensures the opportunity for citizens to be involved in all phases of the planning process.* The development code amendment was reviewed in accordance with the acknowledged provisions for citizen involvement in Warrenton's municipal code, which implement goal 1. The amendment does not restrict

opportunities for citizen involvement. The Development Code's requirements for advertising and hearings are unchanged. Opportunities for citizens to appeal land use decisions are not restricted or narrowed by the amendment. Based on this, the City Commission finds that the amendment is consistent with Statewide Planning Goal 1.

#### **Statewide Planning Goal 2, Land Use Planning**

Goal 2 requires that local governments "*establish a land use planning process and policy framework as a basis for all decisions and actions related to use of land and to assure an adequate factual base for such decisions and actions.*" The amendment fits into the City's land use planning processes and policy framework. The amendment clarifies marijuana uses as Conditional Uses within the C-1 and I-1 Zoning Districts. The amendment does not alter the basic framework for planning and decision-making in Warrenton. Based on this, the City Commission finds the amendment consistent with Statewide Planning Goal 2.

#### **Statewide Planning Goal 3, Agricultural Lands**

Not applicable

#### **Statewide Planning Goal 4, Forest Lands**

Not applicable

#### **Statewide Planning Goal 5, Natural Resources, Scenic and Historic Areas, and Open Spaces**

The basic aim of Goal 5 is "*To protect natural resources and conserve scenic and historic areas and open spaces.*" The City's goal 5 implementation measures in its Comprehensive Plan and Development Code are unaffected by the proposed amendment. Goal 5 protection measures remain in force in those areas affected by these amendments. The amendment does not add any new resources to the City's Goal 5 inventories, or take any resources out of these inventories, or alter prior decisions concerning those goal 5 resources. Based on this, the City Commission finds the amendment consistent with Statewide Planning Goal 5.

#### **Statewide Planning Goal 6, Air, Water and Land Resources**

Goal 6 is "*to maintain and improve the quality of the air, water and land resources of the state.*" It deals mainly with control of "waste and process discharges from future development." The amendment does not affect any of the City's goal 6 implementation measures. These implementation measures, in the Development Code and the Comprehensive Plan, remain in effect. Based on this, the City Commission Finds that the amendments are consistent with Statewide Planning Goal 6.

#### **Statewide Planning Goal 7, Areas Subject to Natural Hazards**

Goal 7 is to *"to protect people and property from natural hazards."* The City's goal 7 implementation measures are not changed by the amendment. The Flood Hazard Overlay Zone and the Soil Hazard Overlay zone are two of the City's principal goal 7 implementation tools. These are unchanged by the amendment. Those areas subject to goal 7 are still subject to the City's goal 7 implementation measures. Based on this, the City Commission finds the amendments do not conflict with Statewide Planning Goal 7.

#### **Statewide Planning Goal 8, Recreational Needs**

Goal 8 is *"to satisfy the recreational needs of the citizens of the state and visitors and, where appropriate, to provide for the siting of necessary recreational facilities including destination resorts."* The City's goal 8 needs are met by lands that are zoned primarily for recreational purposes. The amendment does not change this. The amendment does not alter the City's approach to meeting its goal 8 obligations, or any goal 8 implementation measures. None of the City's Goal 8 Comprehensive Plan policies are changed by the amendment. Based on this, the City Commission finds that the amendment is consistent with Statewide Planning Goal 8.

#### **Statewide Planning Goal 9, Economic Development**

Goal 9 is *"to provide adequate opportunities throughout the state for a variety of economic activities vital to the health, welfare, and prosperity of Oregon's citizens."* The amendment has no impact on the City's ability to meet its goal 9 obligations. The amendment does not reduce the City's inventory of buildable commercial or industrial lands. The amendment makes a minor change to the process for reviewing new commercial or industrial development, but does not strip an applicant's ability to apply for a marijuana business, it simply provides an opportunity for Planning Commission to mitigate any detrimental impacts through the Conditional Use process. Based on this, the City Commission finds the amendment consistent with Statewide Planning Goal 9.

#### **Statewide Planning Goal 10, Housing**

Goal 10 is *"to provide for the housing needs of citizens of the state."* The goal requires cities to assess future need for various housing types and to plan and zone sufficient buildable land to meet those projected needs. The amendment has no impact on land available for housing in Warrenton; nor does it change the substantive or procedural requirements for approval of new residential development; nor does it alter the mix of housing types allowed in the City. Based on this, the City Commission finds the amendments consistent with Statewide Planning Goal 10.

#### **Statewide Planning Goal 11, Public Facilities and Services**

Goal 11 is *"to plan and develop a timely, orderly and efficient arrangement of public facilities and services to serve as a framework for urban and rural development."* The amendment does not change any of the City's goal 11 implementation measures. The supply of developable

lands, and the capacity of public facilities needed to serve those lands, are unchanged by the amendment. The amendment has no impact on City policies regarding the expansion and financing of public facilities. Based on this, the City Commission finds the amendment consistent with Statewide Planning Goal 11.

#### **Statewide Planning Goal 12, Transportation**

Goal 12 is *"to provide and encourage a safe, convenient and economic transportation system."* The City's goal 12 implementation measures are unaffected by the amendment. Warrenton's existing transportation infrastructure and the City's plans for future expansion of transportation facilities are unchanged by the amendment. Current and likely future transportation demand is not affected by the amendments. Based on this, the City Commission finds the development code amendment consistent with Statewide Planning Goal 12.

#### **Statewide Planning Goal 13, Energy**

Goal 13 is simply *"to conserve energy"*. The City's goal 13 implementation measures are unchanged by the amendment. Based on this, the City Commission finds that the amendment is consistent with Statewide Planning Goal 13.

#### **Statewide Goal 14, Urbanization**

Goal 14 is *"to provide for an orderly and efficient transition from rural to urban land use, to accommodate urban population and urban employment inside urban growth boundaries, to ensure efficient use of land, and to provide for livable communities."* The amendment does not conflict with this goal: it moves an existing permitted use to a conditional use. The amendment does not alter the UGB. None of the City's goal 14 implementation measures are affected by the amendment. Based on this, the City Commission finds the amendments consistent with Statewide Planning Goal 14.

#### **Statewide Planning Goal 15, Willamette River Greenway**

Not applicable

#### **Statewide Planning Goal 16, Estuarine Resources**

Goal 16 is *"to recognize and protect the unique environmental, economic, and social values of each estuary and associated wetlands; and to protect, maintain, where appropriate develop, and where appropriate restore the long-term environmental, economic, and social values, diversity and benefits of Oregon's estuaries."* The City's primary goal 16 implementation measures are the estuarine resources element of its comprehensive plan; the development code's Aquatic Natural, Aquatic Conservation, and Aquatic Development zones; and the development code's Columbia River Estuary Shoreland and Aquatic Area Development

Standards. These implementation measures are unaffected by the amendment. Based on this, the City Commission finds the amendment consistent with Statewide Planning Goal 16.

#### **Statewide Planning Goal 17, Coastal Shorelands**

Goal 17 aims *“to conserve, protect, where appropriate, develop and where appropriate restore the resources and benefits of all coastal shorelands, recognizing their value for protection and maintenance of water quality, fish and wildlife habitat, water-dependent uses, economic resources and recreation and aesthetics.”* The City implements goal 17 primarily through the Coastal Shorelands element of its comprehensive plan; and through the development code’s Coastal Lake and Freshwater Wetlands Zone, and Water-Dependent Industrial Shorelands Zone. The amendment does not change any of these implementation measures. Based on this, the City Commission finds that the amendment is consistent with Statewide Planning Goal 17.

#### **Statewide Planning Goal 18, Beaches and Dunes**

Goal 18 is: *“To conserve, protect, where appropriate develop, and where appropriate restore the resources and benefits of coastal beach and dune areas; and to reduce the hazard to human life and property from natural or man-induced actions associated with these areas.”* The City’s basic implementation measures for goal 18 are the Comprehensive plan’s beaches and dunes element, and the development code’s Beach and Dune Overlay District. The amendment does not change any of these implementation measures, or the City’s overall goal 18 planning strategy. Based on this, the City Commission finds that the amendment is consistent with Statewide Planning Goal 18.

#### **Statewide Planning Goal 19, Ocean Resources**

Not applicable

Ordinance 1249  
Introduced by All Commissioners

AN ORDINANCE AMENDING WARRENTON MUNICIPAL CODE TITLE 16,  
DEVELOPMENT CODE, DIVISION 2, LAND USE DISTRICTS, CHAPTER 16.40,  
GENERAL COMMERCIAL (C-1), AND CHAPTER 16.60, GENERAL  
INDUSTRIAL (I-1)

WHEREAS, the City Commission finds it appropriate to amend the Development Code's procedural requirements for Marijuana Businesses to assure that the land use decision making process continues to meet the City's needs; and

WHEREAS, the City of Warrenton is best served by land use decisions that mitigate detrimental impacts to surrounding property owners; and

WHEREAS, the City Commission conducted a public hearing on this amendment on April 27, 2021, to receive public testimony and to consider the Planning Commission's recommendation;

NOW, THEREFORE, the City of Warrenton ordains as follows:

**Section 1.** Amend Warrenton Municipal Code Section 16.40, to read as follows:

[new language; deleted language]

16.40.020 Permitted Uses.

~~19. Medical marijuana dispensaries and recreational marijuana retail outlets licensed by the State of Oregon and subject to Section 16.040.060.I.~~

16.40.030 Conditional Uses.

7. Medical marijuana dispensaries and recreational marijuana retail outlets licensed by the State of Oregon and subject to Section 16.40.060.I.

**Section 2.** Amend Warrenton Municipal Code Section 16.60, to read as follows:

[new language; deleted language]

16.60.020 Permitted Uses.

~~F. Recreational marijuana production, recreational marijuana processing, or recreational marijuana wholesale activities, subject to Section 16.60.040.N.~~

16.60.030 Conditional Uses.

D. Recreational marijuana production, recreational marijuana processing, or recreational marijuana wholesale activities, subject to Section 16.60.040.N.

16.60.040 Development Standards.

N. Recreational marijuana production, recreational marijuana processing, and recreational marijuana wholesale activities shall be located only east of Highway 101 and at least 1,000 feet from any public or private school, church, public park or child care center, and shall operate exclusively as a single building occupant or with other licensed medical marijuana dispensaries or recreational marijuana retail outlets. (Ord. 1196-A § 4, 2015)

**Section 3.** This Ordinance shall take full force and effect 30 days upon its adoption by the Commission of the City of Warrenton.

**First Reading: April 27, 2021**

**Second Reading: May 11, 2021**

**ADOPTED by the City Commission of the City of Warrenton, Oregon this May 11, 2021.**

Approved

---

Henry A. Balensifer III, Mayor

Attest

---

Dawne Shaw, City Recorder

3-1-2021

Scott Hess

Community Development Director

City of Warrenton

POB 250

Warrenton, OR 97146

RE: Measure 56- Ordinance No. 1249

Dear Mr. Hess.

My wife and I are property owners at 2187 SE Dolphin Rd., Warrenton, OR. My family has owned this property since 1978. We respectfully object to the proposed amendment to Warrenton Municipal Code 16.40 and 16.60.

The proposed amendment would add marijuana businesses in Commercial and Industrial Zones as Conditional Uses. The nature of the businesses is not defined. In the prior attempt to modify the Warrenton Municipal Code (Measure 56 notice - ordinance 1246) the purpose had been to allow marijuana production, processing and wholesale sales activities. Also an adjacent dispensary and/or retail outlet would have been looming.

If you refer to my 11-28-20 letter you will find information reflecting that residential dwellings decrease in value by an average of 8.4% after a marijuana dispensary was built nearby. As I mentioned before, if that number is accurate, our property would lose approximately \$40,000 in fair market value when the marijuana business opens. To us, that is and will remain, unacceptable.

As we pointed out 11-28-20, marijuana operation and not odor-free. There is a similar marijuana related operation close to where our second home is on the outskirts of Corvallis. Odor from that processing facility can be smelled from more than a mile and a half. Our Corvallis address is less than a half mile from the processing plant and it's sickening to go outside when the wind is blowing toward us from the processing facility.

Lastly, I mentioned 11-28-20 that authorizing a marijuana facility in the proposed location would necessarily prevent additional businesses to build within 1,000' if they were classified as private schools, churches, public parks or child care centers. While it appears the new Warrenton Middle School is located more than 1,000' from the proposed location for this marijuana endeavor, will the Warrenton Planning Commission be responsible to tell school children in the area what the obnoxious odor is they smell in the air?

As I ended my 11-28-20 letter to the planning commission, I asked if you would like a marijuana facility build close to your own residence. Again...I doubt that you would and we ask you for the same consideration.

Sincerely,

Gary K. Moore



Barbara Holt-Moore



#### AGENDA MEMORANDUM

TO: The Warrenton City Commission  
FROM: Richard Stelzig, Public Works Director  
DATE: April 27<sup>th</sup>, 2021  
SUBJ: Public Improvement Contract – Big River Construction

#### SUMMARY

Warrenton Middle School is installing a new sewer main on SE Dolphin Avenue. Per City ordinance, the properties adjacent to this new sewer main will be required to connect to this new sewer main and pay the associated fees.

Construction of this sewer main and other public improvements are currently ongoing and patching of the new trench lines will take place in the next couple weeks. The City has decided to install four new sewer laterals to provide service to existing homes and a business on SE Dolphin Avenue prior to asphalt patching of the roadway. Public Works sought out quotes for this project and Big River Construction was the only responsive bidder, with a total project cost of \$40,954.00. Attached to this memo is a Public Improvement Contract and a quote submitted by Big River Construction. Big River Construction is currently completing site work for the Warrenton Middle School and NW Natural.

#### RECOMMENDATION/SUGGESTED MOTION

Staff recommends the following motions;

“I move to approve awarding the public improvement contract for the new sewer laterals on Dolphin Avenue to Big River Construction, for the amount of \$40,954.00.”

#### ALTERNATIVE

- 1) Other action as deemed appropriate by the City Commission
- 2) None recommended

FISCAL IMPACT

Funds for this project will be taken out of the sewer construction and materials line of the adopted budget.

Approved by City Manager: Jinda Engleton

All supporting documentation, i.e., maps, exhibits, etc., must be attached to this memorandum.

**CITY OF WARRENTON  
PUBLIC IMPROVEMENT CONTRACT**

**1. GENERAL:**

This contract, made and entered into this \_\_\_ day of \_\_\_\_\_, 2021, by and between the City of Warrenton, a municipal corporation of the State of Oregon, hereinafter called "CITY", and Big River Construction, 35064 Hwy. 101 Business, Astoria, OR 97103 hereinafter called "CONTRACTOR", duly authorized to do business in Oregon.

**WITNESSETH**

That the said CONTRACTOR and the said CITY, for consideration hereinafter named agree as follows:

**2. DESCRIPTION OF WORK:**

The CONTRACTOR agrees to perform the work of:

**SE Dolphin Rd Installation of Four Sewer Laterals**

And do all things required of it as per his bid, all in accordance with the described bid, a copy of which is hereto attached and made a part of this contract.

**3. COMPLETION OF CONTRACT:**

The CONTRACTOR agrees that the work under this contract shall be performed within 10 calendar days of Notice to Proceed. If conditions beyond the control of the CONTRACTOR prevents completion of the project within the time set, CONTRACTOR may request a reasonable extension of time in accordance with APWA General Requirements

**4. CONTRACT PRICE:**

The contract price for this project is \$40,954.00. Payment will be made in accordance with ORS 279C.560 including progress payments at the end of each month. Retainage will be withheld in accordance with ORS 279C.550 - .570.

Requests for payments will be submitted to City of Warrenton Accounts Payable, P.O. Box 250, Warrenton, OR 97146 or [ap@ci.warrenton.or.us](mailto:ap@ci.warrenton.or.us).

**5. CONTRACT DOCUMENTS:**

The CONTRACTOR and the CITY agree that the plans, specifications (including the APWA Oregon Chapter 1990 Standard Specifications for Public Works Construction with 1996 revisions), general conditions, supplementary conditions, call for bids, special provisions to the engineering specifications, instructions to bidders, all addenda and all modifications thereto and bid are, by this reference, incorporated into this contract and are fully a part of this contract.

**6. CHANGES IN WORK:**

With the consent of the CONTRACTOR's surety, the CITY may change the plans, specification, character of the work, or quantity of work, provided the total value of all such changes, both additive and deductive, does not exceed the following:

- A. An increase or decrease of more than 25 percent of the total cost of the work calculated from the original proposal quantities and the unit contract prices; or,
- B. An increase or decrease of more than 25 percent in the quantity of any one major contract item.

For condition "B" above, a major item is defined as any item that amounts to 10 percent or more of the total contract price. If it is necessary to exceed this limitation, the change shall be by written supplemental agreement between the CONTRACTOR and CITY.

Any change shall be in writing and state the dollar value, method of payment, and any adjustments in contract time, and shall provide for the signatures of the CONTRACTOR and CITY.

Changes in plans and specifications, requested in writing by the CONTRACTOR, which do not materially affect the work, may be granted by the Engineer. Payment will be made in accordance with Section 60.4.00 of this contract.

**7. COMPLIANCE:**

The CONTRACTOR specifically agrees to comply with all laws, ordinances, and regulations applicable to municipal contracts and to make prompt payment of all amounts that may be due from said CONTRACTOR in the way of taxes or lawful deductions and to make prompt payment of all labor and materials, and

save the CITY harmless from any damages or claims whatsoever in the performance of this contract.

The CONTRACTOR further agrees to comply with all laws, ordinances, rules, orders and regulations relating to the performance of the work, the protection of adjacent property, and the maintenance of passageways, guard fences, or other protective facilities.

CONTRACTOR agrees to take every precaution against injuries to persons or damage to property.

The CONTRACTOR agrees that the work will be done to the satisfaction and approval of the Engineer of Record of the City of Warrenton.

CONTRACTOR agrees to store his apparatus, materials, supplies and equipment in such orderly fashion at the site of the work as will not unduly interfere with the progress of their work or the work of any other employees or persons.

CONTRACTOR agrees to hold the CITY free and harmless from all liability to persons and property for failure to leave the premises in a safe condition and to make payment to all persons employed by them in such project.

**8. ADDITIONAL CONTRACTOR RESPONSIBILITIES:**

CONTRACTOR is responsible for obtaining and paying for all necessary permits.

CONTRACTOR shall verify existing conditions and locations of all utilities and shall notify the Engineer of any discrepancies that may affect the work.

CONTRACTOR is responsible for contacting the utilities to have the lines relocated or repaired as necessary.

**9. CONTRACTOR IS INDEPENDENT CONTRACTOR:**

- A. CONTRACTOR'S services shall be provided under the general supervision of City's project director or his designee, but CONTRACTOR shall be an independent CONTRACTOR for all purposes and shall be entitled to no compensation other than the compensation provided for under Section 4 of this Contract.
- B. CONTRACTOR acknowledges that for all purposes related to this contract, CONTRACTOR is and shall be deemed to be an independent CONTRACTOR and not an employee of the CITY, shall not be entitled to

benefits of any kind to which an employee of the CITY is entitled and shall be solely responsible for all payments and taxes required by law; and furthermore in the event that CONTRACTOR is found by a court of law or an administrative agency to be an employee of the CITY for any purpose, CITY shall be entitled to offset compensation due, or, to demand repayment of any amounts paid to CONTRACTOR under the terms of the contract, to the full extent of any benefits or other remuneration CONTRACTOR receives (from CITY or third party) as result of said finding and to the full extent of any payments that CITY is required to make (to CONTRACTOR or a third party) as a result of said finding.

- C. The undersigned CONTRACTOR hereby represents that no employee of the City of Warrenton, or any partnership or corporation in which a City of Warrenton employee has an interest, has or will receive any remuneration of any description from the CONTRACTOR, either directly or indirectly, in connection with the letting or performance of this contract, except as specifically declared in writing.

**10. SUBCONTRACTS – RELATIONS WITH SUBCONTRACTORS, ASSIGNMENTS AND DELEGATION:**

- A. CONTRACTOR shall be fully responsible for the acts or omissions of any subcontractors and of any persons employed by them, and neither the approval by CITY of any subcontractor nor anything contained herein shall be deemed to create any contractual relation between subcontractor and CITY.
- B. CONTRACTOR's relations with subcontractors shall comply with ORS 279C.580. In accordance with that statute:
  - 1. CONTRACTOR shall include in each subcontract for property or services entered into by the CONTRACTOR and a first-tier subcontractor, including a material supplier, for the purpose of performing a construction contract:
    - (a) A payment clause that obligates the CONTRACTOR to pay the first-tier subcontractor for satisfactory performance under its subcontract within 10 days out of such amounts as are paid to the CONTRACTOR by the contracting agency under the contract; and
    - (b) An interest penalty clause that obligates the CONTRACTOR, if payment is not made within 30 days after receipt of payment from the contracting agency, to pay to the first-tier subcontractor an interest penalty on amounts due in the case of each payment not made in

accordance with the payment clause included in the subcontract under paragraph (a) of this subsection. A CONTRACTOR or first-tier sub-contractor may not be obligated to pay an interest penalty if the only reason that the CONTRACTOR or first-tier subcontractor did not make payment when payment was due is that the CONTRACTOR or first-tier sub-contractor did not receive payment from the contracting agency or CONTRACTOR when payment was due. The interest penalty shall be: (A) For the period beginning on the day after the required payment date and ending on the date on which payment of the amount due is made; and (B) Computed at the rate specified on ORS 279C.515(2).

2. CONTRACTOR shall include in each of the CONTRACTOR's subcontracts, for the purpose of performance of such contract condition, a provision requiring the first-tier subcontractor to include a payment clause and an interest penalty clause conforming to the standards of subsection (1) of this section in each of the first-tier subcontractor's subcontracts and to require each of the first-tier subcontractor's subcontractors to include such clauses in their subcontracts with each lower-tier subcontractor or supplier.

The above required clauses are required by ORS 279.C.580 (3) and (4) and all the provisions of ORS 179C.580 are applicable.

- C. CONTRACTOR certifies that all subcontractors performing work described in ORS 701.005(3) or ORS 671.520(1) will be registered with the Construction Contractors Board or by the State Landscape Contractors Board before the subcontractors commence work under this contract.
- D. Assignment or Transfer Restricted. The CONTRACTOR shall not assign, sell, dispose of, or transfer rights nor delegate duties under the contract, either in whole or in part, without the CITY's prior written consent. Unless otherwise agreed by the CITY in writing, such consent shall not relieve the CONTRACTOR of any obligations under the contract. Any assignee or transferee shall be considered the agent of the CONTRACTOR and be bound to abide by all provisions of the contract. If the CITY consents in writing to an assignment, sale, disposal or transfer of the CONTRACTOR's rights or delegation of the CONTRACTOR's duties, the CONTRACTOR and its surety, if any, shall remain liable to the CITY for complete performance of the contract as if no such assignment, sale, disposal, transfer or delegation had occurred unless the CITY otherwise agrees in writing.
- E. CONTRACTOR certifies that CONTRACTOR has not discriminated and will not discriminate against minority, women or small business enterprises in obtaining any required subcontracts.

## 11. EARLY TERMINATION:

- A. This contract may be terminated without cause by mutual written consent of the parties. In addition, the parties may agree to terminate the contract:
1. If work under the contract is suspended by an order of a public agency for any reason considered to be in the public interest other than by a labor dispute or by reason of any third-party judicial proceeding relating to the work other than a suite or action filed in regard to a labor dispute; or
  2. If the circumstances or conditions are such that it is impracticable within a reasonable time to proceed with a substantial portion of the Contract.
- B. Payment. When a Contract, or any divisible portion thereof, is terminated pursuant to this section, the CITY shall pay the CONTRACTOR a reasonable amount of compensation for preparatory work completed and for costs and expenses arising out of termination. The CITY shall also pay for all work completed, based on the contract price. Unless the work completed is subject to unit or itemized pricing under the Contract, payment shall be calculated based on percent of contract completed. No claim for loss of anticipated profits will be allowed.
- C. Responsibility for Completed Work. Termination of the contract or a divisible portion thereof pursuant to this section shall not relieve either the CONTRACTOR or its surety of liability for claims arising out of the work performed.
- D. Termination under any provision of this paragraph shall not affect any right, obligation or liability of CONTRACTOR or CITY which accrued prior to such termination.
- E. If work is suspended under circumstances described in A (1) but the contract is not terminated; the CONTRACTOR is entitled to a reasonable extension of time to complete the contract, and reasonable compensation for all costs resulting from the suspension plus reasonable allowance for overhead with respect to such costs.

## 12. CANCELLATION FOR CAUSE:

CITY may cancel all or any part of this Contract if CONTRACTOR breaches any of the terms herein or in the event of any of the following: Insolvency of CONTRACTOR; voluntary or involuntary petition in bankruptcy by or against CONTRACTOR; appointment of a receiver or trustee for CONTRACTOR, or any assignment for benefit of creditors of CONTRACTOR. Damages for breach shall be those allowed by Oregon law, reasonable and necessary attorney's fees, and other costs of litigation at trial and upon appeal. CONTRACTOR may likewise cancel all or any part of this contract if CITY breaches any of the terms herein and be therefore entitle to equivalent damages as expressed above for CITY.

**13. NONWAIVER:**

The failure of the CITY to insist upon or enforce strict performance by CONTRACTOR of any of the terms of this Contract or to exercise any rights hereunder shall not be construed as a waiver or relinquishment to any extent of its right to assert or rely upon such terms or rights on any future occasion.

**14. REMEDIES:**

Consequences for CONTRACTOR's failure to perform the scope of work identified in the invitation to bid or the CONTRACTOR's failure to meet established performance standards may include, but are not limited to:

- (A) Reducing or withholding payment;
- (B) Requiring the CONTRACTOR to perform, at the CONTRACTOR's expense, additional work necessary to perform the identified scope of work or meet the established performance standards; or
- (C) Declaring a default, terminating the public contract, and seeking damages and other relief available under the terms of the public contract or other applicable law.

**15. SUIT OR ACTION:**

In the event suit or action is instituted to enforce any of the terms of this agreement, the prevailing party shall be entitled to recover from the other party such sum as the Court may adjudge reasonable as attorney's fees at trial or on appeal of such suit or action, in addition to all other sums provided by law.

**16. CONFLICT BETWEEN TERMS:**

It is further expressly agreed by and between the parties hereto that should there be any conflict between the terms of this instrument and the bid of the CONTRACTOR, this instruments shall control and nothing herein shall be considered as an acceptance of the said terms of said bid conflicting herewith.

**17. INDEMNIFICATION:**

CONTRACTOR agrees to indemnify and hold harmless the City of Warrenton, its officers, employees, and agents against and from any and all loss, claims, actions, suits, including costs and attorney fees and expenses for or on account of injury, bodily or otherwise to, or death of persons, damage to or destruction of property belonging to CITY, CONTRACTOR, or others, resulting from or arising out of CONTRACTOR's negligence in relation to work performed under this Contract.

**18. WORKMEN'S COMPENSATION:**

The CONTRACTOR, its subcontractors, if any, and all employers working under this Contract, in the State of Oregon, shall comply with ORS 656.017, and provide the required Worker's Compensation coverage, unless such employers are exempt under ORS 656.126. CONTRACTOR shall ensure that each of its subcontractors complies with these requirements. (ORS 279C.530 (2)).

**LABORERS AND MATERIALMENT, CONTRIBUTIONS TO INDUSTRIAL ACCIDENT FUND, LIENS AND WITHHOLDING TAXES:**

CONTRACTOR shall make payment promptly, as due, to all persons supplying CONTRACTOR labor or material for the prosecution of the work provided for this contract.

CONTRACTOR shall pay all contributions or amounts due the Industrial Accident Fund from CONTRACTOR or any subcontractor incurred in the performance of the contract.

CONTRACTOR shall not permit any lien or claim to be filed or prosecuted against the state, county, school district, municipality, municipal corporation or subdivision thereof, on account of any labor or material furnished.

CONTRACTOR shall pay to the Department of Revenue all sums withheld from employees pursuant to ORS 316.167.

**19. PAYMENT OF CLAIMS BY PUBLIC OFFICERS; PAYMENT TO PERSONS FURNISHING LABOR AND MATERIALS; AND COMPLAINTS:**

- A. If the CONTRACTOR fails, neglects or refuses to make prompt payment of any claim for labor or services furnished to the CONTRACTOR or a subcontractor by any person in connection with the public contract as such claim becomes due, the proper officer or officers representing the municipality may pay such claim to the person furnishing the labor or

services and charge the amount of the payment against funds due or to become due the CONTRACTOR by reason of such contract.

- B. If the CONTRACTOR or a first-tier subcontractor fails, neglects or refuses to make payment to a person furnishing labor or material in connection with the public contract for a public improvement within 30 days after receipt of payment from the public contracting agency or a CONTRACTOR, the CONTRACTOR, or first-tier subcontractor shall owe the person the amount due plus interest charges that begin at the end of the 10-day period within which payment is due under ORS 279C.580(4) and end upon final payment, unless payment is subject to a good faith dispute as defined in 279C.580. The rate of interest on the amount due is nine percent per annum. The amount of interest may not be waived.
- C. If the CONTRACTOR or a subcontractor fails, neglects, or refuses to make payment to a person furnishing labor or materials in connection with the public contract, the person may file a complaint with the Construction Contractors Board, unless payment is subject to a good faith dispute as defined in ORS 279.580.
- D. The payment of a claim in the manner authorized in this section shall not relieve the CONTRACTOR or the CONTRACTOR's surety from obligation with respect to any unpaid claims.

## **20. HOURS OF LABOR:**

No person shall be employed for more than 10 hours in any one day, or 40 hours in any one week, except in cases of necessity, emergency, or when the public policy absolutely requires it, and in such cases, except in cases of contracts for personal service as defined in ORS 279C.100, the employee shall be paid at least time and a half pay:

- A. For all overtime in excess of eight hours in any one day or 40 hours in any one week when the work week is four consecutive days, Monday through Friday; or
- B. For all overtime in excess of 10 hours in any one day or 40 hours in any one week when the work week is five consecutive days, Monday through Friday; and
- C. For all work performed on Saturday and on any legal holiday specified in ORS 279C.540.
- D. CONTRACTOR must give notice to employees who work on a public contract in writing, either at the time of hire or before commencement of

work on the contract, or by posting a notice in a location frequented by employees of the number of hours per day and days per week that the employees may be required to work.

- E. CONTRACTOR will comply with the requirements of ORS 279.C545 regarding time limitation on a claim for overtime by posting a circular as described in that statute.

**21. PAYMENT OF MEDICAL CARE:**

Contractor shall promptly, as due, make payment to any person, co-partnership, association or corporation, furnishing medical, surgical and hospital care or other needed care and attention, incident to sickness or injury to the employees of such CONTRACTOR, of all sums which the CONTRACTOR agrees to pay for such services and all moneys and sums which the CONTRACTOR collected or deducted from the wages of employees pursuant to any law, contract or agreement for the purpose of providing or paying for such services.

**22. DRUG TESTING PROGRAM:**

CONTRACTOR shall demonstrate, to the satisfaction of the Public Works Director that an employee drug-testing program is in place. CONTRACTOR may attach hereto a written description of his drug testing program, or a copy of the adopted drug-testing program, to comply with this condition.

**23. PREVAILING WAGE:**

- A. Prevailing Wage Rate: The CONTRACTOR is required to pay prevailing wage rates in conformance to ORS 279C.800 thru 279C.845. A current copy (title page only) of Prevailing Wage Rates for Public Works contracts in Oregon is included in Section \_\_\_\_ of the specifications. The website address where these publications are available is: <http://www.oregon.gov/BOLI/WHD/PWR/pwrdb2.shtml>. All subcontracts shall contain a provision that workers shall be paid not less than the prevailing wage rate.
- B. Workers must be paid not less than the minimum hourly rate of wage in accordance with ORS 279C.808 and 279C.840. This provision must also be included in every subcontract.
- C. Statutory Public Works Bond. CONTRACTOR shall have a Public Works bond on file with the Construction Contractors Board before starting work on the project, unless exempt under the terms of ORS 279C.836. CONTRACTOR shall include a provision in every subcontract requiring the subcontractor to have a public works bond on file with the

Construction Contractors Board before starting work on the project, unless exempt under the terms of ORS 279C.836.

- D. Certified Payroll Reports. CONTRACTOR or CONTRACTOR's surety and every subcontractor or subcontractor's surety shall file certified payroll reports with the CITY in conformance with ORS 279C.845. The CITY and, when appropriate, CONTRACTOR, is required to withhold 25% of amounts earned by CONTRACTOR, or subcontractor, if certified payroll reports are not submitted as required, pursuant to ORS 279C.845(7) and (8).

#### **24. INSURANCE:**

Prior to starting work hereunder, CONTRACTOR, at CONTRACTOR's cost, shall secure and continue to carry during the term of this contract, with an insurance company acceptable to CITY, the following insurance.

- A. **Commercial General Liability.** Contractor shall obtain, at contractor's expense and keep in effect during the term of this contract, Commercial General Liability Insurance covering bodily injury and property damage with limits of not less than \$1,000,000 per occurrence and the annual aggregate of not less than \$2,000,000. Coverage shall include contractors, subcontractors and anyone directly or indirectly employed by either. This insurance will include personal and advertising injury liability, products and completed operations. Coverage may be written in combination with Automobile Liability Insurance (with separate limits). Coverage will be written on an occurrence basis. If written in conjunction with Automobile Liability the combined single limit per occurrence will not be less than \$1,000,000 for each job site or location. Each annual aggregate limited will not be less than \$2,000,000.
- B. **Automobile Liability.** Contract shall obtain, at Contractor's expense and keep in effect during the term of the resulting Contract, Commercial Business Automobile Liability Insurance covering all owned, non-owned, or hired vehicles. This coverage may be written in combination with the Commercial General Liability Insurance (with separate limits). Combined single limit per occurrence will not be less than \$1,000,000.
- C. **Additional Insured.** The liability insurance coverage shall include City and its officers and employees as Additional Insured but only with respect to Contractor's activities to be performed under this Contract. Coverage will be primary and non-contributory with any other insurance and self-insurance. Prior to starting work under this Contract, Contract shall furnish a certificate to City from each insurance company providing insurance showing that the City is an additional insured, the required coverage is in force, stating policy

numbers, dates of expiration and limits of liability, and further stating that such coverage is primary and not contributory.

- D. **Notice of Cancellation or Change.** There will be no cancellation, material change, potential exhaustion or aggregate limits or non-renewal of insurance coverage(s) without thirty (30) days written notice from Contractor or its insurer(s) to City. Any failure to comply with the reporting provision of this clause will constitute a material breach of this Contract and will be grounds for immediate termination of this Agreement.

**25. PERFORMANCE AND PAYMENT BOND:**

The CONTRACTOR further agrees to furnish a performance bond and a payment bond in approved forms each in the amount of 100% for the full performance and payment of the terms of this contract.

**26. CERTIFICATION OF COMPLIANCE WITH TAX LAWS:**

As required by ORS 305.385(6), CONTRACTOR certifies under penalty of perjury that the CONTRACTOR, to the best of CONTRACTORS's knowledge, is not in violation of any of the tax laws described in ORS 305.380.(4)

**27. CITY BUSINESS LICENSE:**

Prior to starting work CONTRACTOR shall pay the CITY business license tax and provide the Public Works Department with a copy of business license receipt. CONTRACTOR shall, likewise, require all subcontractors to pay the CITY business license tax and provide a copy of the receipt to the Public Works Department prior to commencement of work.

**28. BUILDING PERMIT & INSPECTIONS:**

Prior to starting work, CONTRACTOR shall purchase a valid building permit, when required, and call for inspections in a timely manner. Penalties will be deducted from retainage and a Final Inspection must be completed prior to CONTRACTOR receiving final payment.

**29. NO THIRD-PARTY BENEFICIARIES:**

This contract gives no rights or benefits to anyone other than the CITY and CONTRACTOR and has no third-party beneficiaries.

IN WITNESS WHEREOF, the parties hereto have executed this contract the day and year first written above.

CITY of Warrenton, a municipal  
corporation of the State of Oregon

BY: \_\_\_\_\_  
Mayor Date

ATTEST:

BY: \_\_\_\_\_  
City Recorder Date

\_\_\_\_\_  
Contractor:

PUBLIC IMPROVEMENT CONTRACT  
CITY OF WARRENTON  
UPDATED: June 2012  
joycecowfile2(P)/forms/public improvement contract



35064 Hwy. 101 Business | Astoria, OR 97103  
 Phone: 503-338-3878 | Fax: 503-325-3119  
 OR CCB # 147632 | WA L&I # BIGRIE\*955DW  
 www.bigrivercompanies.com

Contact: Ryan Lampi  
 Email: rlampi@bigrivercompanies.com

Quote To: Collin Stelzig Job Name: Dolphin SS Lateral Stubs  
 City of Warrenton  
 Email: rstelzig@ci.warrenton.or.us Date Quoted: 3/22/21  
 Date of Plans:

Prevailing Wage Rates  
 SS Laterals Stubbed w/in 4' of property line

ITEM	DESCRIPTION	UNIT	AMOUNT
	MOBIZATION & GENERAL CONDITIONS	LS	
	4" PVC SANITARY SEWER LATERALS	EA	
	TRENCH PREP & PATCHING	LS	
	FLAGGING	LS	
<b>GRAND TOTAL</b>			<b>\$40,954.00</b>

**NOTES:**

- Exclusions:
- Inspection/testing fees/bonds
- Engineering/survey/construction staking
- Permits and/or connection fees
- Hazardous material removal/abatement
- Extra depth of pipe bedding/pipe foundation stabilization
- Abandonment or removal of underground structures(including but not limited to: wells, septic or piping)
- Cast-in-place concrete
- Striping & signage
- Bid is based on preliminary plans
- Dewatering/unsuitable subgrades



#### AGENDA MEMORANDUM

TO: The Warrenton City Commission  
 FROM: Richard Stelzig, Public Works Director  
 DATE: April 27th, 2021  
 SUBJ: Public Improvement Contract – Bergerson Construction

#### SUMMARY

The City requested quotes to provide temporary aluminum tide gates at two of the tide gates (tide gates #4.2 and #4.4) located at Alder Creek. These temporary tide gates may be in place for up to a year while existing gates are repaired and will be expected to operate and be durable like a permanent tide gate. Bergerson Construction was the lowest responsive bidder for a total of \$41,450.00. Items in their scope of work include tide gate removal and installation of temporary tide gates. Work will be anticipated to take place in late May or early June of 2021.

#### RECOMMENDATION/SUGGESTED MOTION

Staff recommends the following motions;

“I move to approve awarding the public improvement contract for the Alder Creek Tide Gate Structure, Tidegates #4.2 and #4.4 Repair, to Bergerson Construction, for the amount of \$41,450.00”

#### ALTERNATIVE

- 1) Other action as deemed appropriate by the City Commission
- 2) None recommended

#### FISCAL IMPACT

Funds for this project will be taken out of the sewer construction and materials line of the adopted budget.

Approved by City Manager:

All supporting documentation, i.e., maps, exhibits, etc., must be attached to this memorandum.

**CITY OF WARRENTON  
PUBLIC IMPROVEMENT CONTRACT**

**1. GENERAL:**

This contract, made and entered into this \_\_\_ day of \_\_\_\_\_, 2021, by and between the City of Warrenton, a municipal corporation of the State of Oregon, hereinafter called "CITY", and Bergerson Construction, PO Box 387, Astoria, OR 97103 hereinafter called "CONTRACTOR", duly authorized to do business in Oregon.

**WITNESSETH**

That the said CONTRACTOR and the said CITY, for consideration hereinafter named agree as follows:

**2. DESCRIPTION OF WORK:**

The CONTRACTOR agrees to perform the work of:

**Alder Creek Tide Gate Structure, Tidegates #4.2 and #4.4**

And do all things required of it as per his bid, all in accordance with the described bid, a copy of which is hereto attached and made a part of this contract.

**3. COMPLETION OF CONTRACT:**

The CONTRACTOR agrees that the work under this contract shall be performed within 10 calendar days of Notice to Proceed. If conditions beyond the control of the CONTRACTOR prevents completion of the project within the time set, CONTRACTOR may request a reasonable extension of time in accordance with APWA General Requirements

**4. CONTRACT PRICE:**

The contract price for this project is \$41,450.00. Payment will be made in accordance with ORS 279C.560 including progress payments at the end of each month. Retainage will be withheld in accordance with ORS 279C.550 - .570.

Requests for payments will be submitted to City of Warrenton Accounts Payable, P.O. Box 250, Warrenton, OR 97146 or [ap@ci.warrenton.or.us](mailto:ap@ci.warrenton.or.us).

**5. CONTRACT DOCUMENTS:**

The CONTRACTOR and the CITY agree that the plans, specifications (including the APWA Oregon Chapter 1990 Standard Specifications for Public Works Construction with 1996 revisions), general conditions, supplementary conditions, call for bids, special provisions to the engineering specifications, instructions to bidders, all addenda and all modifications thereto and bid are, by this reference, incorporated into this contract and are fully a part of this contract.

**6. CHANGES IN WORK:**

With the consent of the CONTRACTOR's surety, the CITY may change the plans, specification, character of the work, or quantity of work, provided the total value of all such changes, both additive and deductive, does not exceed the following:

- A. An increase or decrease of more than 25 percent of the total cost of the work calculated from the original proposal quantities and the unit contract prices; or,
- B. An increase or decrease of more than 25 percent in the quantity of any one major contract item.

For condition "B" above, a major item is defined as any item that amounts to 10 percent or more of the total contract price. If it is necessary to exceed this limitation, the change shall be by written supplemental agreement between the CONTRACTOR and CITY.

Any change shall be in writing and state the dollar value, method of payment, and any adjustments in contract time, and shall provide for the signatures of the CONTRACTOR and CITY.

Changes in plans and specifications, requested in writing by the CONTRACTOR, which do not materially affect the work, may be granted by the Engineer. Payment will be made in accordance with Section 60.4.00 of this contract.

**7. COMPLIANCE:**

The CONTRACTOR specifically agrees to comply with all laws, ordinances, and regulations applicable to municipal contracts and to make prompt payment of all amounts that may be due from said CONTRACTOR in the way of taxes or lawful deductions and to make prompt payment of all labor and materials, and

save the CITY harmless from any damages or claims whatsoever in the performance of this contract.

The CONTRACTOR further agrees to comply with all laws, ordinances, rules, orders, and regulations relating to the performance of the work, the protection of adjacent property, and the maintenance of passageways, guard fences, or other protective facilities.

CONTRACTOR agrees to take every precaution against injuries to persons or damage to property.

The CONTRACTOR agrees that the work will be done to the satisfaction and approval of the Engineer of Record of the City of Warrenton.

CONTRACTOR agrees to store his apparatus, materials, supplies, and equipment in such orderly fashion at the site of the work as will not unduly interfere with the progress of their work or the work of any other employees or persons.

CONTRACTOR agrees to hold the CITY free and harmless from all liability to persons and property for failure to leave the premises in a safe condition and to make payment to all persons employed by them in such project.

**8. ADDITIONAL CONTRACTOR RESPONSIBILITIES:**

CONTRACTOR is responsible for obtaining and paying for all necessary permits.

CONTRACTOR shall verify existing conditions and locations of all utilities and shall notify the Engineer of any discrepancies that may affect the work.

CONTRACTOR is responsible for contacting the utilities to have the lines relocated or repaired, as necessary.

**9. CONTRACTOR IS INDEPENDENT CONTRACTOR:**

- A. CONTRACTOR'S services shall be provided under the general supervision of City's project director or his designee, but CONTRACTOR shall be an independent CONTRACTOR for all purposes and shall be entitled to no compensation other than the compensation provided for under Section 4 of this Contract.
- B. CONTRACTOR acknowledges that for all purposes related to this contract, CONTRACTOR is and shall be deemed to be an independent CONTRACTOR and not an employee of the CITY, shall not be entitled to

benefits of any kind to which an employee of the CITY is entitled and shall be solely responsible for all payments and taxes required by law; and furthermore in the event that CONTRACTOR is found by a court of law or an administrative agency to be an employee of the CITY for any purpose, CITY shall be entitled to offset compensation due, or, to demand repayment of any amounts paid to CONTRACTOR under the terms of the contract, to the full extent of any benefits or other remuneration CONTRACTOR receives (from CITY or third party) as result of said finding and to the full extent of any payments that CITY is required to make (to CONTRACTOR or a third party) as a result of said finding.

- C. The undersigned CONTRACTOR hereby represents that no employee of the City of Warrenton, or any partnership or corporation in which a City of Warrenton employee has an interest, has or will receive any remuneration of any description from the CONTRACTOR, either directly or indirectly, in connection with the letting or performance of this contract, except as specifically declared in writing.

**10. SUBCONTRACTS – RELATIONS WITH SUBCONTRACTORS, ASSIGNMENTS AND DELEGATION:**

- A. CONTRACTOR shall be fully responsible for the acts or omissions of any subcontractors and of any persons employed by them, and neither the approval by CITY of any subcontractor nor anything contained herein shall be deemed to create any contractual relation between subcontractor and CITY.
- B. CONTRACTOR's relations with subcontractors shall comply with ORS 279C.580. In accordance with that statute:
  - 1. CONTRACTOR shall include in each subcontract for property or services entered into by the CONTRACTOR and a first-tier subcontractor, including a material supplier, for the purpose of performing a construction contract:
    - (a) A payment clause that obligates the CONTRACTOR to pay the first-tier subcontractor for satisfactory performance under its subcontract within 10 days out of such amounts as are paid to the CONTRACTOR by the contracting agency under the contract; and
    - (b) An interest penalty clause that obligates the CONTRACTOR, if payment is not made within 30 days after receipt of payment from the contracting agency, to pay to the first-tier subcontractor an interest penalty on amounts due in the case of each payment not made in

accordance with the payment clause included in the subcontract under paragraph (a) of this subsection. A CONTRACTOR or first-tier sub-contractor may not be obligated to pay an interest penalty if the only reason that the CONTRACTOR or first-tier subcontractor did not make payment when payment was due is that the CONTRACTOR or first-tier sub-contractor did not receive payment from the contracting agency or CONTRACTOR when payment was due. The interest penalty shall be: (A) For the period beginning on the day after the required payment date and ending on the date on which payment of the amount due is made; and (B) Computed at the rate specified on ORS 279C.515(2).

2. CONTRACTOR shall include in each of the CONTRACTOR's subcontracts, for the purpose of performance of such contract condition, a provision requiring the first-tier subcontractor to include a payment clause and an interest penalty clause conforming to the standards of subsection (1) of this section in each of the first-tier subcontractor's subcontracts and to require each of the first-tier subcontractor's subcontractors to include such clauses in their subcontracts with each lower-tier subcontractor or supplier.

The above required clauses are required by ORS 279.C.580 (3) and (4) and all the provisions of ORS 179C.580 are applicable.

- C. CONTRACTOR certifies that all subcontractors performing work described in ORS 701.005(3) or ORS 671.520(1) will be registered with the Construction Contractors Board or by the State Landscape Contractors Board before the subcontractors commence work under this contract.
- D. Assignment or Transfer Restricted. The CONTRACTOR shall not assign, sell, dispose of, or transfer rights nor delegate duties under the contract, either in whole or in part, without the CITY's prior written consent. Unless otherwise agreed by the CITY in writing, such consent shall not relieve the CONTRACTOR of any obligations under the contract. Any assignee or transferee shall be considered the agent of the CONTRACTOR and be bound to abide by all provisions of the contract. If the CITY consents in writing to an assignment, sale, disposal or transfer of the CONTRACTOR's rights or delegation of the CONTRACTOR's duties, the CONTRACTOR and its surety, if any, shall remain liable to the CITY for complete performance of the contract as if no such assignment, sale, disposal, transfer or delegation had occurred unless the CITY otherwise agrees in writing.
- E. CONTRACTOR certifies that CONTRACTOR has not discriminated and will not discriminate against minority, women or small business enterprises in obtaining any required subcontracts.

**11. EARLY TERMINATION:**

- A. This contract may be terminated without cause by mutual written consent of the parties. In addition, the parties may agree to terminate the contract:
  - 1. If work under the contract is suspended by an order of a public agency for any reason considered to be in the public interest other than by a labor dispute or by reason of any third-party judicial proceeding relating to the work other than a suite or action filed in regard to a labor dispute; or
  - 2. If the circumstances or conditions are such that it is impracticable within a reasonable time to proceed with a substantial portion of the Contract.
- B. Payment. When a Contract, or any divisible portion thereof, is terminated pursuant to this section, the CITY shall pay the CONTRACTOR a reasonable amount of compensation for preparatory work completed and for costs and expenses arising out of termination. The CITY shall also pay for all work completed, based on the contract price. Unless the work completed is subject to unit or itemized pricing under the Contract, payment shall be calculated based on percent of contract completed. No claim for loss of anticipated profits will be allowed.
- C. Responsibility for Completed Work. Termination of the contract or a divisible portion thereof pursuant to this section shall not relieve either the CONTRACTOR or its surety of liability for claims arising out of the work performed.
- D. Termination under any provision of this paragraph shall not affect any right, obligation or liability of CONTRACTOR or CITY which accrued prior to such termination.
- E. If work is suspended under circumstances described in A (1) but the contract is not terminated; the CONTRACTOR is entitled to a reasonable extension of time to complete the contract, and reasonable compensation for all costs resulting from the suspension plus reasonable allowance for overhead with respect to such costs.

**12. CANCELLATION FOR CAUSE:**

CITY may cancel all or any part of this Contract if CONTRACTOR breaches any of the terms herein or in the event of any of the following: Insolvency of CONTRACTOR; voluntary or involuntary petition in bankruptcy by or against CONTRACTOR; appointment of a receiver or trustee for CONTRACTOR, or any assignment for benefit of creditors of CONTRACTOR. Damages for breach shall be those allowed by Oregon law, reasonable and necessary attorney's fees, and other costs of litigation at trial and upon appeal. CONTRACTOR may likewise cancel all or any part of this contract if CITY breaches any of the terms herein and be therefore entitle to equivalent damages as expressed above for CITY.

**13. NONWAIVER:**

The failure of the CITY to insist upon or enforce strict performance by CONTRACTOR of any of the terms of this Contract or to exercise any rights hereunder shall not be construed as a waiver or relinquishment to any extent of its right to assert or rely upon such terms or rights on any future occasion.

**14. REMEDIES:**

Consequences for CONTRACTOR's failure to perform the scope of work identified in the invitation to bid or the CONTRACTOR's failure to meet established performance standards may include, but are not limited to:

- (A) Reducing or withholding payment;
- (B) Requiring the CONTRACTOR to perform, at the CONTRACTOR's expense, additional work necessary to perform the identified scope of work or meet the established performance standards; or
- (C) Declaring a default, terminating the public contract, and seeking damages and other relief available under the terms of the public contract or other applicable law.

**15. SUIT OR ACTION:**

In the event suit or action is instituted to enforce any of the terms of this agreement, the prevailing party shall be entitled to recover from the other party such sum as the Court may adjudge reasonable as attorney's fees at trial or on appeal of such suit or action, in addition to all other sums provided by law.

**16. CONFLICT BETWEEN TERMS:**

It is further expressly agreed by and between the parties hereto that should there be any conflict between the terms of this instrument and the bid of the CONTRACTOR, this instruments shall control and nothing herein shall be considered as an acceptance of the said terms of said bid conflicting herewith.

**17. INDEMNIFICATION:**

CONTRACTOR agrees to indemnify and hold harmless the City of Warrenton, its officers, employees, and agents against and from any and all loss, claims, actions, suits, including costs and attorney fees and expenses for or on account of injury, bodily or otherwise to, or death of persons, damage to or destruction of property belonging to CITY, CONTRACTOR, or others, resulting from or arising out of CONTRACTOR's negligence in relation to work performed under this Contract.

**18. WORKMEN'S COMPENSATION:**

The CONTRACTOR, its subcontractors, if any, and all employers working under this Contract, in the State of Oregon, shall comply with ORS 656.017, and provide the required Worker's Compensation coverage, unless such employers are exempt under ORS 656.126. CONTRACTOR shall ensure that each of its subcontractors complies with these requirements. (ORS 279C.530 (2)).

**LABORERS AND MATERIALMENT, CONTRIBUTIONS TO INDUSTRIAL ACCIDENT FUND, LIENS AND WITHHOLDING TAXES:**

CONTRACTOR shall make payment promptly, as due, to all persons supplying CONTRACTOR labor or material for the prosecution of the work provided for this contract.

CONTRACTOR shall pay all contributions or amounts due the Industrial Accident Fund from CONTRACTOR or any subcontractor incurred in the performance of the contract.

CONTRACTOR shall not permit any lien or claim to be filed or prosecuted against the state, county, school district, municipality, municipal corporation or subdivision thereof, on account of any labor or material furnished.

CONTRACTOR shall pay to the Department of Revenue all sums withheld from employees pursuant to ORS 316.167.

**19. PAYMENT OF CLAIMS BY PUBLIC OFFICERS; PAYMENT TO PERSONS FURNISHING LABOR AND MATERIALS; AND COMPLAINTS:**

- A. If the CONTRACTOR fails, neglects, or refuses to make prompt payment of any claim for labor or services furnished to the CONTRACTOR or a subcontractor by any person in connection with the public contract as such claim becomes due, the proper officer or officers representing the municipality may pay such claim to the person furnishing the labor or

services and charge the amount of the payment against funds due or to become due the CONTRACTOR by reason of such contract.

- B. If the CONTRACTOR or a first-tier subcontractor fails, neglects or refuses to make payment to a person furnishing labor or material in connection with the public contract for a public improvement within 30 days after receipt of payment from the public contracting agency or a CONTRACTOR, the CONTRACTOR, or first-tier subcontractor shall owe the person the amount due plus interest charges that begin at the end of the 10-day period within which payment is due under ORS 279C.580(4) and end upon final payment, unless payment is subject to a good faith dispute as defined in 279C.580. The rate of interest on the amount due is nine percent per annum. The amount of interest may not be waived.
- C. If the CONTRACTOR or a subcontractor fails, neglects, or refuses to make payment to a person furnishing labor or materials in connection with the public contract, the person may file a complaint with the Construction Contractors Board, unless payment is subject to a good faith dispute as defined in ORS 279.580.
- D. The payment of a claim in the manner authorized in this section shall not relieve the CONTRACTOR or the CONTRACTOR's surety from obligation with respect to any unpaid claims.

## **20. HOURS OF LABOR:**

No person shall be employed for more than 10 hours in any one day, or 40 hours in any one week, except in cases of necessity, emergency, or when the public policy absolutely requires it, and in such cases, except in cases of contracts for personal service as defined in ORS 279C.100, the employee shall be paid at least time and a half pay:

- A. For all overtime in excess of eight hours in any one day or 40 hours in any one week when the work week is four consecutive days, Monday through Friday; or
- B. For all overtime in excess of 10 hours in any one day or 40 hours in any one week when the work week is five consecutive days, Monday through Friday; and
- C. For all work performed on Saturday and on any legal holiday specified in ORS 279C.540.
- D. CONTRACTOR must give notice to employees who work on a public contract in writing, either at the time of hire or before commencement of

work on the contract, or by posting a notice in a location frequented by employees of the number of hours per day and days per week that the employees may be required to work.

- E. CONTRACTOR will comply with the requirements of ORS 279.C545 regarding time limitation on a claim for overtime by posting a circular as described in that statute.

**21. PAYMENT OF MEDICAL CARE:**

Contractor shall promptly, as due, make payment to any person, co-partnership, association or corporation, furnishing medical, surgical and hospital care or other needed care and attention, incident to sickness or injury to the employees of such CONTRACTOR, of all sums which the CONTRACTOR agrees to pay for such services and all moneys and sums which the CONTRACTOR collected or deducted from the wages of employees pursuant to any law, contract or agreement for the purpose of providing or paying for such services.

**22. DRUG TESTING PROGRAM:**

CONTRACTOR shall demonstrate, to the satisfaction of the Public Works Director that an employee drug-testing program is in place. CONTRACTOR may attach hereto a written description of his drug testing program, or a copy of the adopted drug-testing program, to comply with this condition.

**23. PREVAILING WAGE:**

- A. Prevailing Wage Rate: The CONTRACTOR is required to pay prevailing wage rates in conformance to ORS 279C.800 thru 279C.845. A current copy (title page only) of Prevailing Wage Rates for Public Works contracts in Oregon is included in Section \_\_\_\_ of the specifications. The website address where these publications are available is: <http://www.oregon.gov/BOLI/WHD/PWR/pwrdb2.shtml>. All subcontracts shall contain a provision that workers shall be paid not less than the prevailing wage rate.
- B. Workers must be paid not less than the minimum hourly rate of wage in accordance with ORS 279C.808 and 279C.840. This provision must also be included in every subcontract.
- C. Statutory Public Works Bond. CONTRACTOR shall have a Public Works bond on file with the Construction Contractors Board before starting work on the project, unless exempt under the terms of ORS 279C.836. CONTRACTOR shall include a provision in every subcontract requiring the subcontractor to have a public works bond on file with the

Construction Contractors Board before starting work on the project, unless exempt under the terms of ORS 279C.836.

- D. Certified Payroll Reports. CONTRACTOR or CONTRACTOR's surety and every subcontractor or subcontractor's surety shall file certified payroll reports with the CITY in conformance with ORS 279C.845. The CITY and, when appropriate, CONTRACTOR, is required to withhold 25% of amounts earned by CONTRACTOR, or subcontractor, if certified payroll reports are not submitted as required, pursuant to ORS 279C.845(7) and (8).

#### **24. INSURANCE:**

Prior to starting work hereunder, CONTRACTOR, at CONTRACTOR's cost, shall secure and continue to carry during the term of this contract, with an insurance company acceptable to CITY, the following insurance.

- A. **Commercial General Liability.** Contractor shall obtain, at contractor's expense and keep in effect during the term of this contract, Commercial General Liability Insurance covering bodily injury and property damage with limits of not less than \$1,000,000 per occurrence and the annual aggregate of not less than \$2,000,000. Coverage shall include contractors, subcontractors and anyone directly or indirectly employed by either. This insurance will include personal and advertising injury liability, products and completed operations. Coverage may be written in combination with Automobile Liability Insurance (with separate limits). Coverage will be written on an occurrence basis. If written in conjunction with Automobile Liability the combined single limit per occurrence will not be less than \$1,000,000 for each job site or location. Each annual aggregate limited will not be less than \$2,000,000.
- B. **Automobile Liability.** Contract shall obtain, at Contractor's expense and keep in effect during the term of the resulting Contract, Commercial Business Automobile Liability Insurance covering all owned, non-owned, or hired vehicles. This coverage may be written in combination with the Commercial General Liability Insurance (with separate limits). Combined single limit per occurrence will not be less than \$1,000,000.
- C. **Additional Insured.** The liability insurance coverage shall include City and its officers and employees as Additional Insured but only with respect to Contractor's activities to be performed under this Contract. Coverage will be primary and non-contributory with any other insurance and self-insurance. Prior to starting work under this Contract, Contract shall furnish a certificate to City from each insurance company providing insurance showing that the City is an additional insured, the required coverage is in force, stating policy

numbers, dates of expiration and limits of liability, and further stating that such coverage is primary and not contributory.

- D. **Notice of Cancellation or Change.** There will be no cancellation, material change, potential exhaustion or aggregate limits or non-renewal of insurance coverage(s) without thirty (30) days written notice from Contractor or its insurer(s) to City. Any failure to comply with the reporting provision of this clause will constitute a material breach of this Contract and will be grounds for immediate termination of this Agreement.

**25. PERFORMANCE AND PAYMENT BOND:**

The CONTRACTOR further agrees to furnish a performance bond and a payment bond in approved forms each in the amount of 100% for the full performance and payment of the terms of this contract.

**26. CERTIFICATION OF COMPLIANCE WITH TAX LAWS:**

As required by ORS 305.385(6), CONTRACTOR certifies under penalty of perjury that the CONTRACTOR, to the best of CONTRACTORS's knowledge, is not in violation of any of the tax laws described in ORS 305.380.(4)

**27. CITY BUSINESS LICENSE:**

Prior to starting work CONTRACTOR shall pay the CITY business license tax and provide the Public Works Department with a copy of business license receipt. CONTRACTOR shall, likewise, require all subcontractors to pay the CITY business license tax and provide a copy of the receipt to the Public Works Department prior to commencement of work.

**28. BUILDING PERMIT & INSPECTIONS:**

Prior to starting work, CONTRACTOR shall purchase a valid building permit, when required, and call for inspections in a timely manner. Penalties will be deducted from retainage and a Final Inspection must be completed prior to CONTRACTOR receiving final payment.

**29. NO THIRD-PARTY BENEFICIARIES:**

This contract gives no rights or benefits to anyone other than the CITY and CONTRACTOR and has no third-party beneficiaries.

IN WITNESS WHEREOF, the parties hereto have executed this contract the day and year first written above.

CITY of Warrenton, a municipal  
corporation of the State of Oregon

BY: \_\_\_\_\_  
Mayor Date

ATTEST:

BY: \_\_\_\_\_  
City Recorder Date

\_\_\_\_\_  
Contractor:

PUBLIC IMPROVEMENT CONTRACT  
CITY OF WARRENTON  
UPDATED: June 2012  
joycecowfile2'(P)/forms/public improvement contract

P.O. Box 387  
Astoria, OR 97103  
Office 503-325-7130  
Fax 503-325-0174  
24 Hour Service



TIN # 93-0600594  
OR CCB# 63328  
WA CC01 BERGEC1210H  
info@bergeron-const.com  
www.bergeron-const.com

April 1, 2021

City of Warrenton  
Attn: Richard Stelzig  
45 SW 2<sup>nd</sup> St.  
Warrenton, OR 97146  
[rstelzig@ci.warrenton.or.us](mailto:rstelzig@ci.warrenton.or.us)

Project: **City of Warrenton – Alder Creek Tide Gate Structure**  
RE: **Tide Gate 4.2 and 4.4 Replacement**

Bergerson Construction is pleased to provide this **Proposal** for materials, equipment, labor and required insurance for the following scope of work on the above-referenced project.

**Tide Gate Repairs**

---

- 1. Mobilization & Demobilization (1 LS) \$ 2,450**
  - a. Includes mobilizing and demobilizing boom truck, work skiff, shop van and misc. tools and equipment required for existing Tide Gate Removal and installation of Temporary Tide Gates.
  
- 2. Tide Gate 4.2 Replacement (1 LS) \$19,500**
  - a. Includes removal of existing 64"x64" Cast Iron Tide Gate, Hinge Assembly with Pins and delivery of existing Tide Gate to City of Warrenton Public Works.
  - b. Includes furnish and installation of Temporary 64" x 64" Aluminum Tide Gate with similar arm and hinge assembly. Temporary Aluminum Tide Gates are to be installed utilizing the existing Pin Sleeves on the existing cast iron Gate Seal or to be supported by an Anchor Plate and Hinge assembly epoxy anchored into the concrete above the existing Cast Iron Gate Seal on the head wall. See conceptual detail drawings attached for additional information.
  - c. Some of the existing Cast Iron Gate Seal is water worn beyond repair, preventing the gates from completely sealing off back flow water through the gate. Other than minor mechanical grinding, no repairs to the existing seal is included in the pricing above. Owner will need to visually inspect seal at minus tide once gate has been removed and provide direction further direction if additional repairs are deemed necessary. All repairs to existing gate seal will be at additional cost.
  
- 3. Tide Gate 4.4 Replacement (1 LS) \$19,500**
  - a. Includes removal of existing 64"x64" Cast Iron Tide Gate, Hinge Assembly with Pins and delivery of existing Tide Gate to City of Warrenton Public Works.
  - b. Includes furnish and installation of Temporary 64" x 64" Aluminum Tide Gate with similar arm and hinge assembly. Temporary Aluminum Tide Gates are to be installed utilizing the existing Pin Sleeves on the existing cast iron Gate Seal or to be supported by an Anchor Plate and Hinge assembly epoxy anchored into the concrete above the existing Cast Iron Gate Seal on the head wall. See conceptual detail drawings attached for additional information.
  - c. Some of the existing Cast Iron Gate Seal is water worn beyond repair, preventing the gates from completely sealing off back flow water through the gate. Other than

minor mechanical grinding, no repairs to the existing seal is included in the pricing above. Owner will need to visually inspect seal at minus tide once gate has been removed and provide direction further direction if additional repairs are deemed necessary. All repairs to existing gate seal will be at additional cost.

**Total**           \$ 41,450.00

**Project Notes / Schedule / Work Plan**

1. Work is anticipated to take place late May or Early June 2021 when Lower Low Water occurs during daylight hours.
2. An Estimated duration of 3 days on site is anticipated.
3. Temporary Tide Gates have an approx. 30-to-40-day Lead Time from NTP.
4. Tide gates will be replaced during low water utilizing a Boom Truck staged on top of the existing dike and a work skiff placed in the water to provide work access to hardware connections. Tide Gates will be removed and temporary tide gates installed during one tide cycle. The tide gate box culvert will not be left open during any tide cycle.
5. See attached conceptual details of the temporary Aluminum Tide Gates proposed for the project.

**EXCLUSIONS:**

- |                                |   |
|--------------------------------|---|
| 1. Engineering                 | 6. Special Inspection & Testing         |
| 2. Bond (add 1.3% if required) | 7. Permanent Materials Unless Specified |
| 3. Permits                     | 8. Diving Services                      |
| 4. Engineering                 | 9. Tide Gate Seal & Seat Repairs        |
| 5. Excavation & Backfill       | 10. Weekend / Night Work                |

Thank you for the opportunity to provide this construction proposal. Please feel free to contact me personally with any questions, or if I am not available please contact Greg Morrill at 503-325-7130.

Respectfully,

Adam Neahring  
Project Manager/Estimator

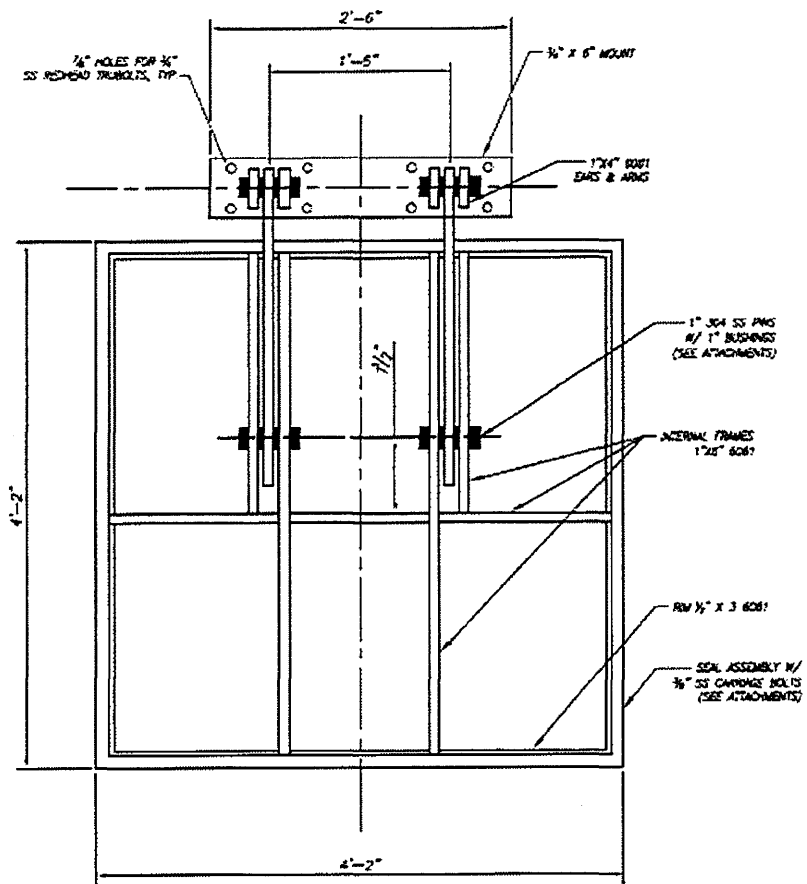

TIDEGATE ELEVATION  
 1 1/2" = 1'-0"

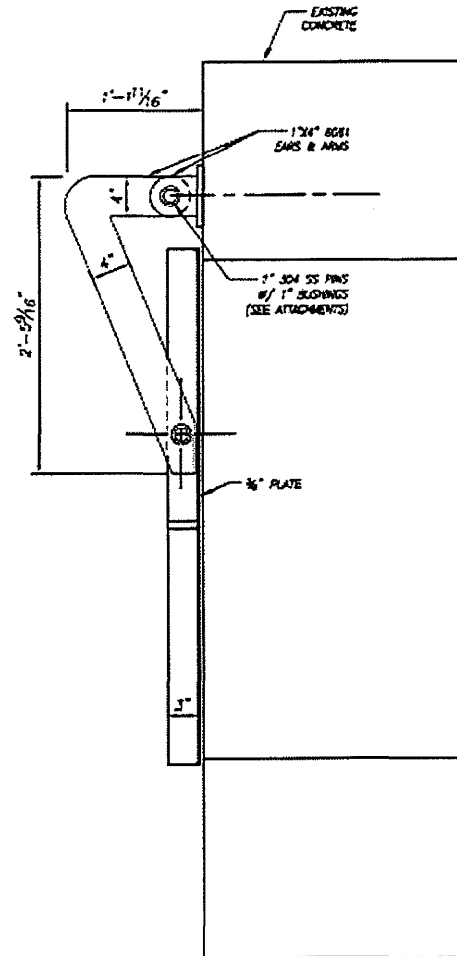

TIDEGATE SECTION  
 1 1/2" = 1'-0"

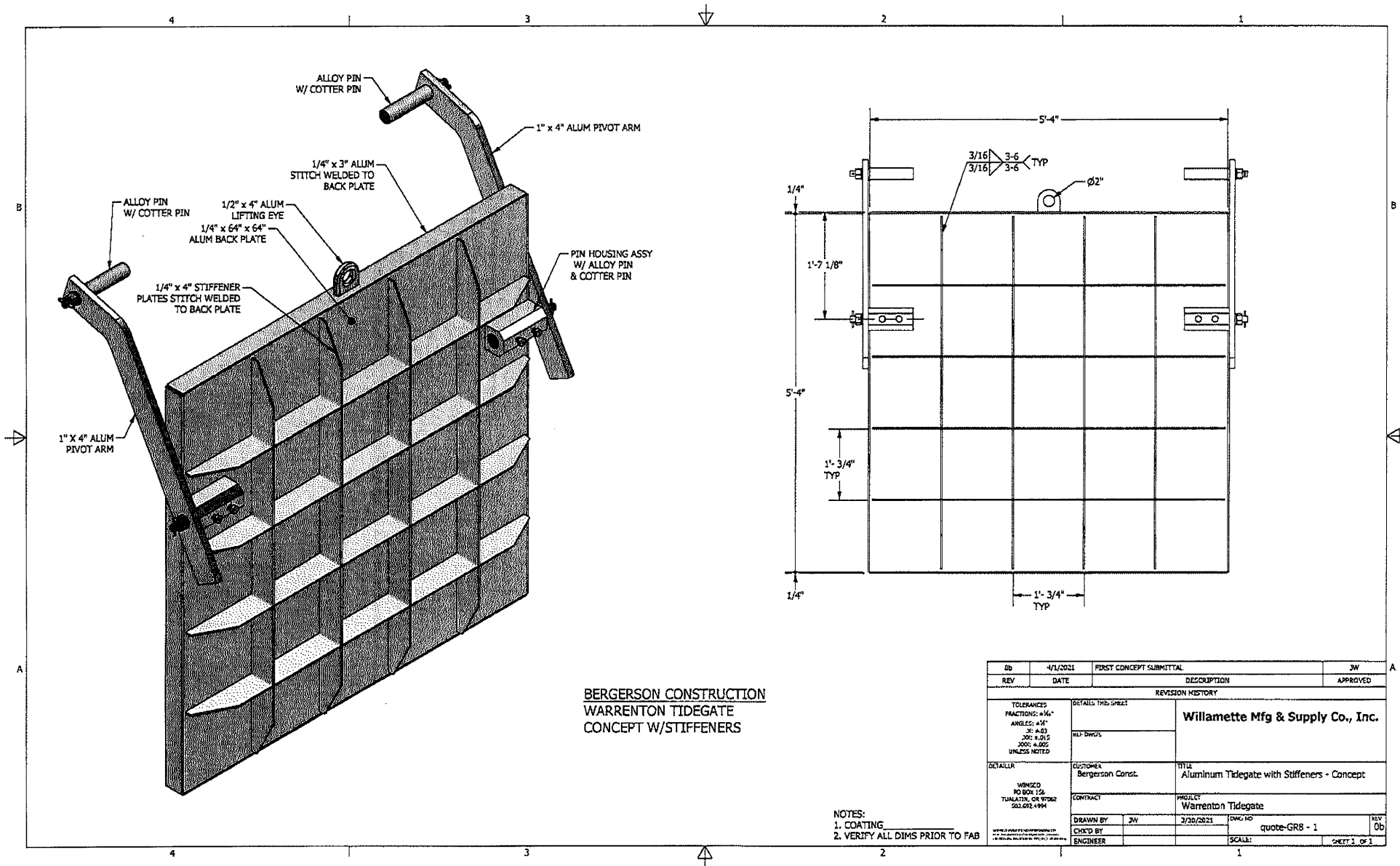

**BERGERSON CONSTRUCTION  
WARRENTON TIDEGATE  
CONCEPT W/STIFFENERS**

- NOTES:**  
 1. COATING  
 2. VERIFY ALL DIMS PRIOR TO FAB

Ob	4/1/2021	FIRST CONCEPT SUBMITTAL	JW
REV	DATE	DESCRIPTION	APPROVED
REVISION HISTORY			
TOLERANCES: FRACTIONS: +1/16" ANGLES: ±1° DIM: ±0.015 200: ±0.002 UNLESS NOTED		DETAILS THIS SHEET	<b>Willamette Mfg &amp; Supply Co., Inc.</b>
DETAILS		REF DWGS	
WANGSD PO BOX 156 TUALATIN, OR 97062 503.692.4998		CUSTOMER Bergerson Const.	TITLE Aluminum Tidegate with Stiffeners - Concept
		CONTRACT	PROJECT Warrenton Tidegate
		DRAWN BY JW	DATE 3/10/2021
		CHK'D BY	DWG NO quote-GR8 - 1
		ENGINEER	SCALE 1" = 1'-0"
			REV Ob
			SHEET 1 OF 1



# AGENDA MEMORANDUM

TO: The Warrenton City Commission  
 FROM: Collin Stelzig, P.E., Public Works Director  
 DATE: April 27, 2021  
 SUBJ: Spring Clean-up Options

## SUMMARY

With the exception of last year, the City has sponsored the popular annual Spring Clean-up for over 30 years. The City opted to add a disposal fee in 2003 to offset some of the increasing costs of the clean-up.

Public Works proposes amending the Sections 1, 3 and 4 of Spring Clean-Up Collection Policy adopted by Resolution 2072 in 2003 and amended to include the additional fees for items that impose extra cost on March 9, 2006. A copy of the proposed Resolution 2598 is attached.

Public Works is recommending a nominal increase in fees to accommodate Recology's fee increases for disposal services and modifying event scheduling to accommodate Astoria Transfer Station availability. A chart of the rate comparisons is below.

Spring Clean-up Rate Comparison				
Spring Clean-Up Fee Items	Proposed	2006 Fees	Recology Minimum Rate	Minimum Savings Per Customer**
Spring Clean-up Load Fee*	\$5.00	\$3.00	\$25.00	\$20.00
Additional Fees				
Tire Charge No Rim Each	\$3.00	\$2.00	\$4.59	\$1.59
Tire Charge On Rim Each	\$6.00	\$4.00	\$9.18	\$3.18
Appliance	\$10.00	\$8.00	\$11.48	\$1.48
Refrigerator/Freezer	\$35.00	\$20.00	\$51.66	\$16.66

\*Truck and Trailer =Two Loads

\*\*Recology minimum rate is based upon tonnage

**RECOMMENDATION/SUGGESTED MOTION**

Public Works recommends the City Commission conduct the first reading of Resolution 2598 amending the Spring Clean-Up Collection Policy.

**ALTERNATIVE**

- 1) Other action as deemed appropriate by the City Commission
- 2) None recommended

**FISCAL IMPACT**

The City Commission budgeted \$12,000.00 for Spring Clean-Up.

<p>Approved by City Manager: _____</p> <p>All supporting documentation, i.e., maps, exhibits, etc., must be attached to this memorandum.</p>
--

**RESOLUTION No. 2598**

**AMENDING RATES AND SCHEDULES TO THE SPRING CLEAN-UP COLLECTION  
POLICY AND REPEALING RESOLUTION 2072**

**WHEREAS**, the City of Warrenton has found that Spring Clean-Up Day is a benefit of the citizens of Warrenton, and;

**WHEREAS**, the success of Spring Clean-Up Day has continued to be a popular event with widespread participation, and;

**WHEREAS**, the City Commission has found it necessary to adopt a formal Spring Clean-Up Day collection policy as a means of controlling the cost to Warrenton's rate payers.

**NOW THEREFORE, THE CITY OF WARRENTON RESOLVES AS FOLLOWS:**

**SECTION 1:** Spring Clean-Up Day will be a one-day event held on a weekend day.

**SECTION 2:** Participants will be required to show that they are a City of Warrenton garbage ratepayers in the City of Warrenton by showing a current City utility bill in the name of the participant.

**SECTION 3:** The City will collect \$5.00 per vehicle and/or trailer load to offset the costs of Spring Clean-Up Day to the ratepayers of Warrenton.

**SECTION 4:** The City retains the ability to collect additional fees for items that impose extra cost on the City as a result of their disposal and sets new rates for the following items.

Tires Off Rim	\$ 3.00	Tires On Rim	\$ 6.00
Refrigerator/Freezers	\$ 35.00	Large Appliances	\$ 8.00

**SECTION 5:** The City maintains the right to reject any materials deemed inappropriate or hazardous.

FIRST READING: April 27, 2021

SECOND READING: May 11, 2021

ADOPTED by the City Commission of the City of Warrenton this 11<sup>th</sup> day of May, 2021.

APPROVED

---

Henry A. Balensifer III, Mayor

ATTEST

---

Dawne Shaw, City Recorder