

Water System Notes:

- SPECIFICATIONS FOR ALL MATERIALS AND CONSTRUCTION SHALL BE IN CONFORMANCE WITH THE 2015 ODOT/APWA SPECIFICATIONS FOR CONSTRUCTION.
- ALL REFERENCES TO AWWA SPECIFICATIONS SHALL MEAN THEIR LATEST REVISION.
- WHERE EXISTING SERVICE MUST BE INTERRUPTED, THE CONTRACTOR SHALL NOTIFY THE CITY AND ALL CUSTOMERS AFFECTED AS TO THE DATE AND DURATION OF THE INTERRUPTION. NOTIFICATION MUST BE DONE 72 HOURS IN ADVANCE OF INTERRUPTION. THE CONTRACTOR SHALL SCHEDULE CONSTRUCTION TO PROVIDE MINIMUM INTERRUPTION OF SERVICE.
- WATER LINE SHALL BE PVC PIPE AND SHALL CONFORM TO AWWA C900 PRESSURE CLASS 235 DR18 WITH GASKETS MEETING ASTM F477 AND JOINTS IN COMPLIANCE WITH ASTM D3139.
- WATER LINES SHALL HAVE COVER OF MINIMUM 36 INCHES BELOW FINISH GRADE.
- ALL POTABLE WATER MAINS SHALL MAINTAIN A SEPARATION OF 10 FEET LATERALLY AND/OR 18 INCHES VERTICALLY ABOVE NON-POTABLE PIPELINES. DEVIATION REQUIRES CITY APPROVAL.
- GATE VALVES SHALL BE RESILIENT WEDGE PER LATEST REVISION OF AWWA C-515.
- CONTRACTOR SHALL POTHOLE ALL EXISTING UTILITIES INCLUDING BUT NOT LIMITED TO WATER LINES, WATER SERVICES, SEWER LATERALS, STORM SEWERS, GAS, POWER, TELEPHONE, CABLE, ETC. PRIOR TO CONSTRUCTING NEW WATER MAIN TO ALLOW VERTICAL ADJUSTMENTS OF NEW WATER MAIN AS NECESSARY.
- ALL TEES, BENDS, HYDRANTS AND BLOW-OFF LOCATIONS SHALL, UNLESS OTHERWISE NOTE, HAVE A POURED-IN-PLACE CONCRETE THRUST BLOCK. THRUST BLOCKS SHALL BE A MINIMUM OF 2,500 PSI CONCRETE.
- PIPE BEDDING AND BACKFILL MATERIAL SHALL CONFORM TO AASHTO T-180 AND BE COMPACTED TO A MINIMUM OF 95% MDD WITHIN STREET SURFACES AND 90% MDD OUTSIDE OF STREET SURFACES, PER TYPICAL TRENCH DETAIL.
- PAVEMENT RESTORATION SHALL BE HMA PER THE TYPICAL TRENCH DETAIL, THIS SHEET.
- BACTERIOLOGICAL SAMPLES SHALL BE TAKEN BY THE CONTRACTOR IN PRESENCE OF CITY STAFF AND TESTED BY A THIRD PARTY TESTING COMPANY.
- NO CONNECTIONS WILL BE ALLOWED TO BE MADE TO AN EXISTING WATERLINE UNTIL AFTER SUCCESSFUL FLUSHING, BACTERIOLOGICAL, AND PRESSURE TESTING THE NEW WATER MAIN. CONTRACTOR WILL BE REQUIRED TO PROVIDE TEMPORARY CAPS, BLOCKING AND A BACKFLOW PREVENTION DEVICE TO FILL, FLUSH AND TEST THE NEW WATER MAIN.
- DISINFECTION AND HYDROSTATIC TESTING SHALL CONFORM WITH THE CITY OF MOLALLA STANDARD 3.03 - WATERLINE TESTING.
- MARKING TAPE SHALL BE INSTALLED 12 INCHES OVER ALL WATER LINES INCLUDING SERVICE LINES. MARKER TAPE SHALL BE BLUE, 3 INCHES WIDE AND READ "CAUTION BURIED WATERLINE BELOW".
- DETECTABLE TRACER WIRE SHALL BE ATTACHED TO ALL WATERLINES. TRACER WIRE SHALL BE ATTACHED TO TOP OF PIPE WITH 2 WRAPS OF DUCT TAPE EVERY 10 FEET. TRACER WIRE SHALL BE #14 AWG HIGH CARBON 1055 GRADE STEEL, HDPE INSULATION, RATED FOR DIRECT BURIAL.
- RECORD DRAWINGS ARE REQUIRED. THE CONTRACTOR SHALL SUPPLY REDLINES OF RECORD AND SUBMIT TO THE CITY AND PACIFIC FIBRE AT COMPLETION OF PROJECT.

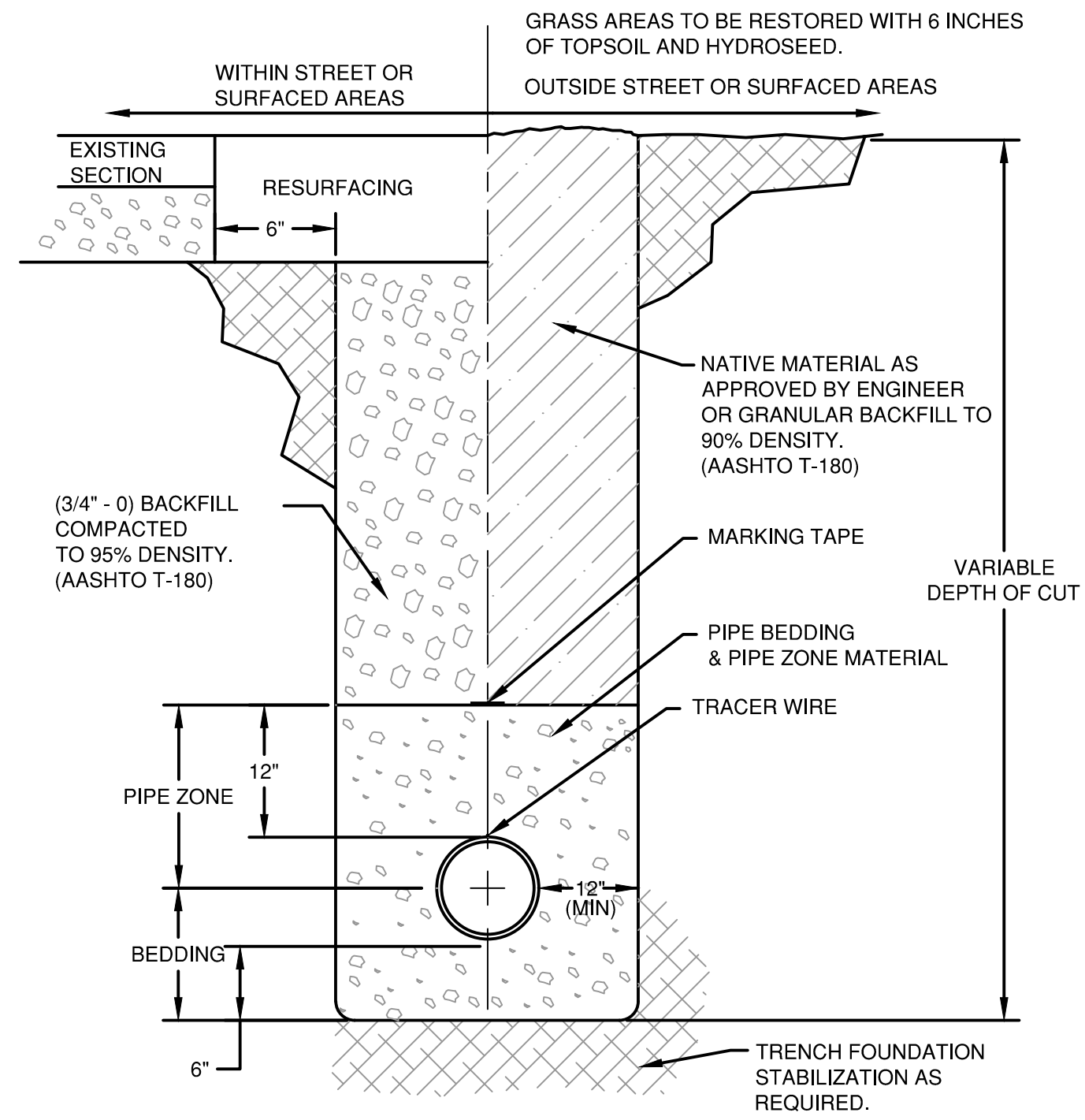

- NOTES:
- ALL CUTS IN PAVEMENT SHALL BE SAW CUT.
 - ALL CUT EDGES SHALL BE SAND SEALED.
 - RESURFACING TO BE MIN. 3" HMA ASPHALT OR MATCH EXISTING WHICHEVER IS GREATER.
 - THIS TRENCH BACKFILL REQUIREMENT APPLIES TO ALL UNDERGROUND CONDUITS.
 - GRANULAR BACKFILL SHALL EXTEND 2 FT. BEYOND EDGE OF STREET OR SURFACED AREA.
 - BACKFILL SHALL BE PLACED AND COMPACTED IN A MAX. OF 6" LIFTS IN PAVEMENT AND A MAXIMUM OF 12" LIFTS OUTSIDE PAVEMENT.

TYPICAL TRENCH DETAIL

N.T.S.

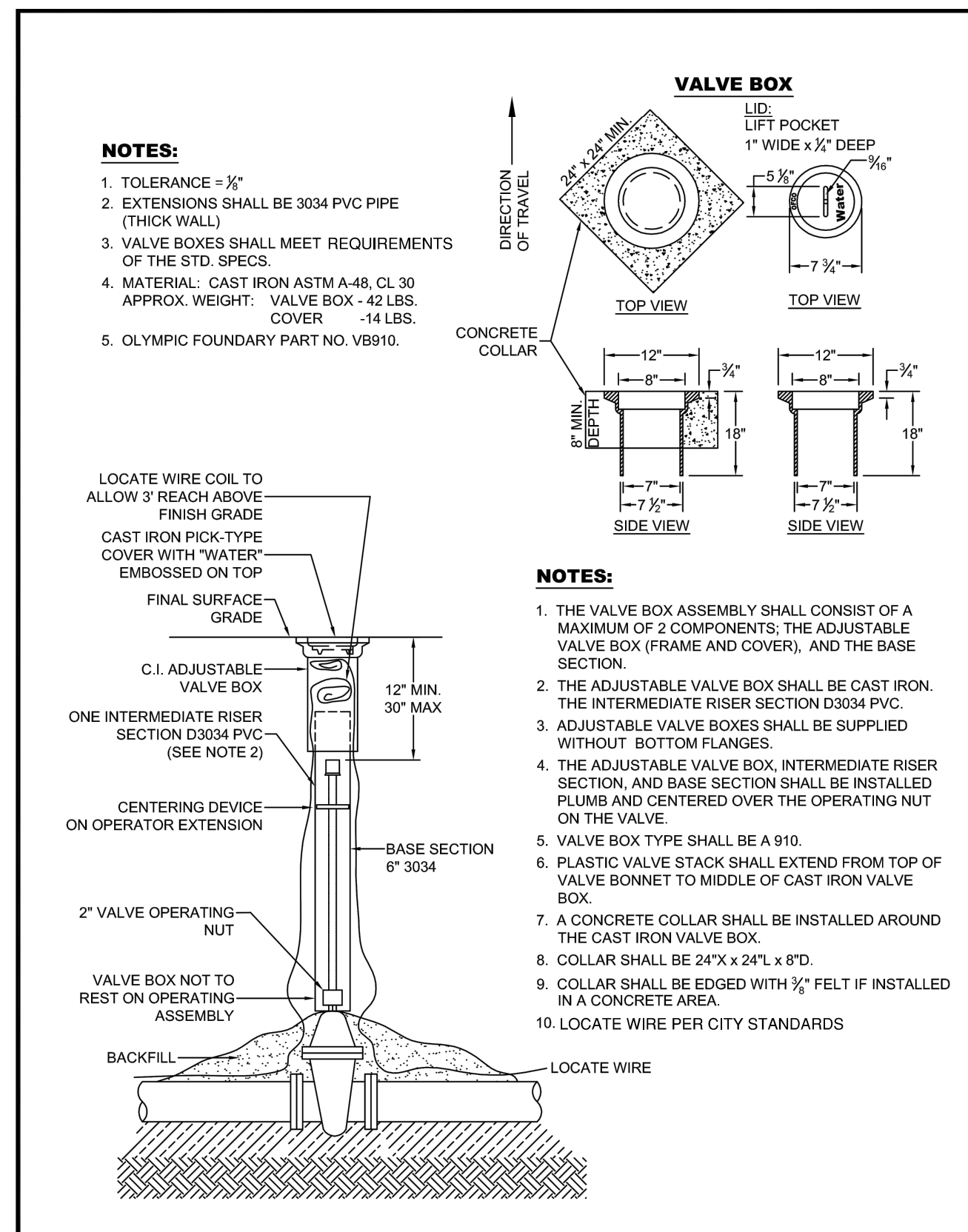

VALVE BOX DETAIL

N.T.S.

(HORIZONTAL)
BEARING AREA OF THRUST BLOCKS IN SQUARE FEET

FITTING SIZE	TEE, WYE DEAD END OR HYDRANT	STRADDLE BLOCK	90° BEND OR PLUGGED CROSS	TEE PLUGGED ON RUN		45° BEND	22-1/2° BEND	11-1/4° BEND
				A-1	A-2			
4	1.0	1.6	1.4	1.9	1.4	1.0	---	---
6	2.1	3.7	3.0	4.3	3.0	1.6	1.0	---
8	3.8	6.5	5.3	7.6	5.4	2.9	1.5	1.0
10	5.9	10.2	8.4	11.8	8.4	4.6	2.4	1.2
12	8.5	14.7	12.0	17.0	12.0	6.6	3.4	1.7
14	11.5	---	16.3	23.0	16.3	8.9	4.6	2.3
16	15.0	26.1	21.3	30.0	21.3	11.6	6.0	3.0
18	19.0	---	27.0	38.0	27.0	14.6	7.6	3.8
20	23.5	40.8	33.3	47.0	33.3	18.1	9.4	4.7
24	34.0	58.8	48.0	68.0	48.0	26.2	13.6	6.8

NOTE:
ABOVE BEARING AREAS BASED ON TEST PRESSURE OF 150 PSI AND AN ALLOWABLE SOIL BEARING STRESS OF 2,000 POUNDS PER SQUARE FOOT. TO COMPUTE BEARING AREAS FOR DIFFERENT TEST PRESSURES AND SOIL BEARING STRESSES, USE THE FOLLOWING EQUATION:
BEARING AREA = (TEST PRESSURE/150) X (2,000/SOIL BEARING STRESS) X (TABLE VALUE)

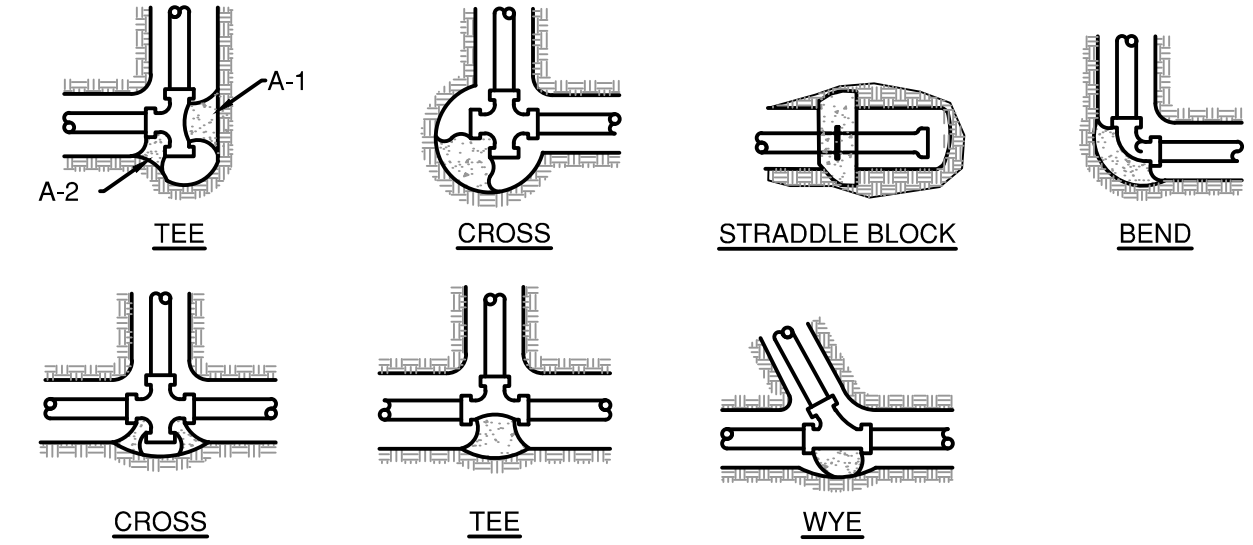

- NOTES:
- CONCRETE BLOCKING TO BE POURED AGAINST UNDISTURBED EARTH.
 - ALL CONCRETE TO BE CLASS 3000 MINIMUM.
 - INSTALL ISOLATION MATERIAL BETWEEN PIPE AND/OR FITTINGS BEFORE POURING CONCRETE BLOCKING.
 - CONCRETE SHALL BE KEPT CLEAR OF ALL JOINTS AND ACCESSORIES.
 - THIS DETAIL ALSO APPLIES TO VERTICAL UP BENDS, EXCEPT BEARING AREA SHALL BE THE BOTTOM OF THE TRENCH.

THRUST BLOCKING DETAIL

N.T.S.

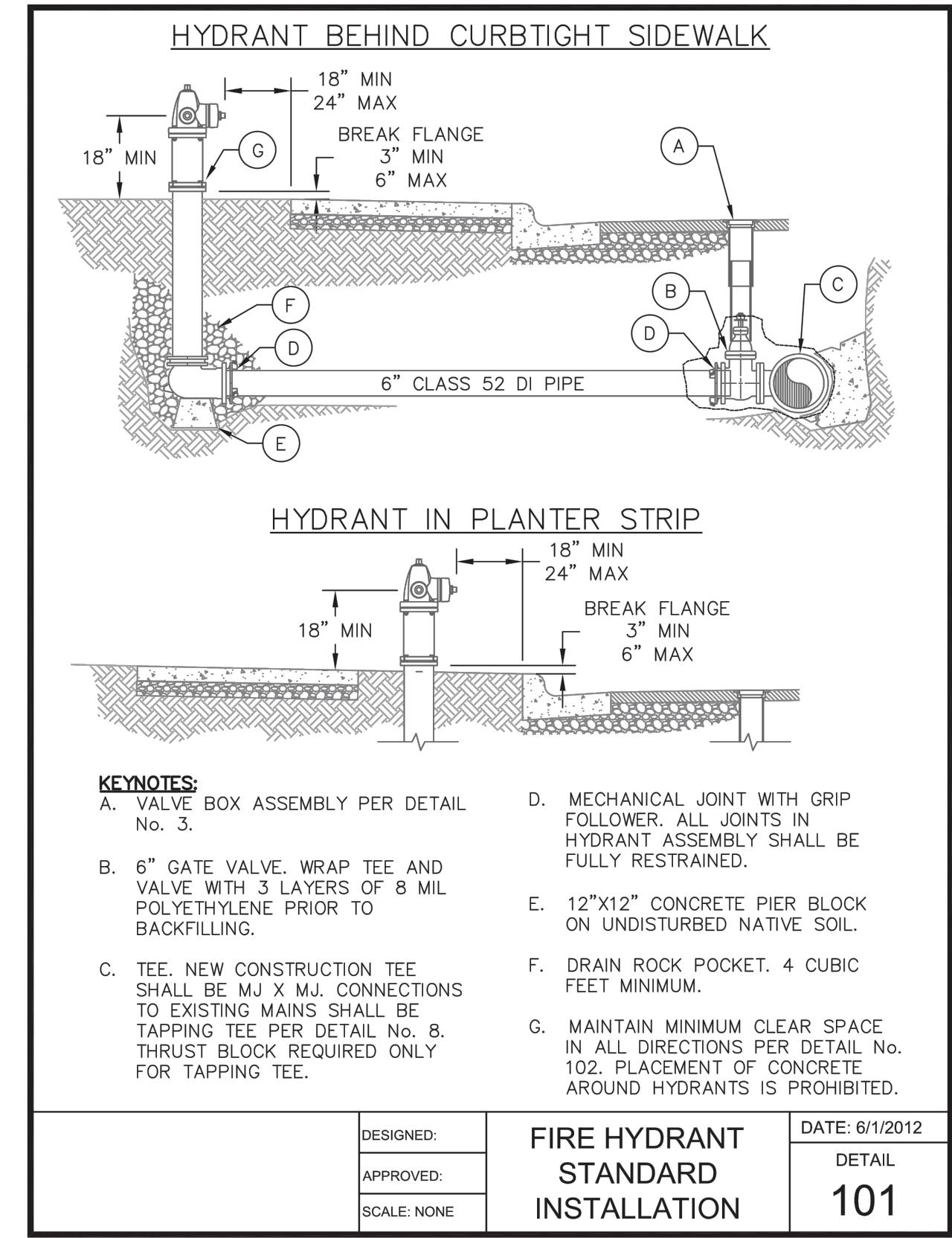

- KEYNOTES:
- VALVE BOX ASSEMBLY PER DETAIL No. 3.
 - 6" GATE VALVE, WRAP TEE AND VALVE WITH 3 LAYERS OF 8 MIL POLYETHYLENE PRIOR TO BACKFILLING.
 - NEW CONSTRUCTION TEE SHALL BE MJ X MJ. CONNECTIONS TO EXISTING MAINS SHALL BE TAPPING TEE PER DETAIL No. 8. THRUST BLOCK REQUIRED ONLY FOR TAPPING TEE.
 - MECHANICAL JOINT WITH GRIP FOLLOWER. ALL JOINTS IN HYDRANT ASSEMBLY SHALL BE FULLY RESTRAINED.
 - 12"x12" CONCRETE PIER BLOCK ON UNDISTURBED NATIVE SOIL.
 - DRAIN ROCK POCKET. 4 CUBIC FEET MINIMUM.
 - MAINTAIN MINIMUM CLEAR SPACE IN ALL DIRECTIONS PER DETAIL No. 102. PLACEMENT OF CONCRETE AROUND HYDRANTS IS PROHIBITED.

DESIGNED:	FIRE HYDRANT STANDARD INSTALLATION	DATE: 6/1/2012
APPROVED:		DETAIL
SCALE: NONE		101

DRAWING: T:\CIVIL\30\PROJECTS\08120104\CONTRACT DRAWINGS\DETAILS.DWG, LAYOUT TAB: D1, PLOT DATE: 3/17/2015 11:57:14 PM, DRAWING SAVE DATE: 3/17/2015 1:47:38 PM, PLOTTED BY: JOLIMA PROFILE: GIBBS & OLSON, STANDARD 2014, PLOT DEVICE: GIBBS & OLSON - DWG TO PDF.PC3, PLOT STYLE: TABLE: GIBBS-OLSON STANDARD MONOCHROME.ctb, PAPER SIZE: GIBBS & OLSON - PLANISHEET D SIZE (34.00 X 22.00 INCHES)

Notes and Details

Pacific Fiber Products
Fire Line Extension
Molalla, Oregon

Horizontal Scale: ---
Vertical Scale: ---
Datum: ---
Survey Book: ---
Project Phase: ---

Project Milestone: ---

Revision Date:
March 31, 2015



3/31/2015
GIBBS & OLSON
www.gibbs-olson.com

Project Manager: JJJ
Designed by: JJJ
CAD by: KR
Checked by: JJJ
Approved by: ---

Project Number:
0812.0104

Drawing Number:
D1

Sheet Number:
4 of 4