

Motor Race Vehicle and Facility Sound Measurement and Procedure Manual

NPCS - 35



REVISION RECORD

INSTRUCTIONS FOR USE: All revisions of this manual will be numbered to assure each manual holder that he has received all revisions. The date, a description of the revision, and the initials of the person inserting the revision shall be listed.

<u>Rev. No.</u>	<u>Date</u>	<u>Description of Revision</u>	<u>Initial</u>
1.	<u>1-8-'83</u>	<u>Delete muffler lengths on non-drag</u>	<u>HH</u>
2.	_____	_____	_____
3.	_____	_____	_____
4.	_____	_____	_____
5.	_____	_____	_____
6.	_____	_____	_____
7.	_____	_____	_____
8.	_____	_____	_____
9.	_____	_____	_____
10.	_____	_____	_____
11.	_____	_____	_____
12.	_____	_____	_____
	_____	_____	_____
	_____	_____	_____
15.	_____	_____	_____

Tables of Contents

	Paragraph
Chapter 1	Introduction
	Policy 1.1
	Authority 1.2
	Noise Regulations for Motor Sports Vehicles and Facilities
	Penalties
	General Vehicle Inspection Procedure 1.5
Chapter 2	Training
	Sound Measurement Equipment
	Noise Control Racing Rules and Procedure Manual
	Race Vehicles and Facilities 2.3
Chapter 3	Muffler Systems
	General 3.1
	Top Fuel Burning Drag Vehicles 3.2
	"Properly Installed" Mufflers 3.3
	"Well Maintained Muffler" Systems 3.4
	Reverse Flow (Baffle) Mufflers 3.4.1
	Perforated Straight Core Mufflers (Glass-packs) 3.4.2
	Annular Swirl Flow (Auger Type) Mufflers 3.4.3
	Stacked 360° Diffuser Discs Mufflers 3.4.4
	Turbocharger 3.4.5
	Go-Kart Mufflers 3.4.6
	Original Manufacturer Muffler on a Motorcycle 3.4.7
	Underwater Exhausted Outboard Boat Motors 3.4.8
	Other Approved Muffling Devices 3.4.9

Other Not Approved Devices

Form NPCS-35-1

Chapter 4 Instrumentation

General	4.1
Sound Level Meter	
Sound Level Meter Calibration	4.2
Field Calibration	4.3.1
Annual Calibration	4.3.2
Accessories	
Sound Measurement Precautions	
Wind	4.5.1
Precipitation	4.5.2
Background Sound Levels	4.5.3
Equipment Setup and Use	
Calibration	4.6.1
Battery	4.6.2
"A" Weighting	4.6.3
"Fast" and "Slow"	4.6.4
Microphone Height	4.6.5
Microphone Orientation	4.6.6
Personnel Location	4.6.7
Range Setting	4.6.8

Chapter 5 Sound Measurement Sites and Procedures

General	5.1
Moving Vehicle Sound Measurement Procedure	5.2
Microphone Height	5.2.1
Blockage of the Sound Path	5.2.2
Reflective Surfaces	5.2.3
50 Ft. Trackside Measurement Point	5.2.4
Alternate 100 Ft. Trackside Measurement Point	5.2.5
Choosing Loudest Moving Vehicle Measurement Point	5.2.6

Stationary Vehicle Sound Measurement Procedure

Test Site	5.3.1
Microphone Location	5.3.2
Vehicle Operation	5.3.3

Sound Measurements

Preliminary Steps	5.4.1
Moving Vehicle Measurements	5.4.2
Stationary Vehicle Measurements	5.4.3
Recording Sound Level Measurements	5.4.4

Form NPC-35-1

Chapter 6 Noise Impact Boundaries

General

List of Figures

Figure		Page
3 - 1	Reverse Flow, Baffled Muffler	7
3 - 2	Perforated Straight Core with Sound Absorbing Medium Muffler	8
3 - 3	Annular Swirl Flow (Auger-Type) Muffler	8
3 - 4	Stacked 360° Diffuser Disc Muffler	9
3 - 5	Go-Kart Muffler Requirements	9
5 - 1	Acceptable Microphone Heights for Moving Vehicle Testing	20
5 - 2	General Layout of Ideal Moving Vehicle Sound Measurement Site	21
5 - 3	Stationary Vehicle Microphone Location	22
5 - 4	Example of Form NPC-35-1	23

CHAPTER 1

INTRODUCTION

1.1 Policy.

1.1.1 The Environmental Quality Commission (EQC), through the Department of Environmental Quality (DEQ) shall establish a noise measurement program to implement the laws and regulations applying to Motor Sports Vehicles and Facilities.

1.1.2 The person owning or controlling the motor sports facility shall be responsible for compliance with the Oregon Noise Control Regulations for Motor Sports Vehicles and Facilities (OAR 340-35-040).

1.1.3 This manual contains procedures to be followed in complying with the Motor Sports Vehicles and Facilities Noise Control Regulations. Guidance is provided in the "Notes" and "Comments".

Authority. The statutory and administrative law governing authority which provide guidance and direction for this manual are contained in:

- a) Oregon Revised Statutes, Chapter 467
- b) Oregon Administrative Rules for Noise Control
 - i) OAR 340-35-005 Policy
 - ii) OAR 340-35-010 Exceptions
 - iii) OAR 340-35-015 Definitions
 - iv) OAR 340-35-040 Noise Control Regulations for Motor Sports Vehicles and Facilities
 - v) OAR 340-35-100 Variances

Noise Regulations for Motor Sports Vehicles and Facilities. The DEQ Noise Control Regulations for Motor Sports Vehicles and Facilities contain two basic requirements for racing vehicles:

- 1) Vehicles shall be equipped with a "properly installed and well maintained muffling" system; and
- 2) Vehicles shall not exceed the maximum allowable noise emission limits for that vehicle.

Facilities located over two miles from the nearest "noise sensitive property" (residences) and/or any Top Fuel Burning Drag race vehicles are exempt from the above requirements due to lack of available control technology.

Penalties. The motor sports facility and racing vehicle owner is subject to penalties set forth by the Environmental Quality Commission in OAR 340-12-052, Noise Control Schedule of Civil Penalties, for violation of the Noise Control Regulations for Motor Sports Vehicles and Facilities. Penalties may be as great as \$500 for each violation.

1.5 General Vehicle Inspection Procedure. As stated in the policy section, the facility owner is required to inspect the race vehicles for compliance with the noise regulations. The following general procedures shall be followed when inspecting race vehicles:

1. Prior to a racing event (normally during the technical inspection of the vehicle), the facility owner shall inspect the muffler system to determine if the vehicle has a "properly installed and well maintained muffling" system (see Chapter 3).
2. If the vehicle has failed to meet the muffler requirements during the above inspection, then the race vehicle does not comply with the regulations and must therefore install a "properly installed and well maintained muffling" system.
3. If the vehicle meets the muffler requirements, then the vehicle (except for a drag race vehicle) shall be sound measured to determine if it meets the maximum allowable noise emission limits.

Vehicles other than motorcycles shall be noise tested while moving around the course (preferably during practice sessions). Open course motorcycles shall be tested while stationary (normally during technical inspection after the muffler inspection). Closed course motorcycles shall be tested while either stationary or moving at the option of the facility owner. (See Chapter 4 and 5).

4. If the vehicle has failed to meet the maximum allowable noise emission limits, then the vehicle does not comply with the regulations and the muffling system must be improved to comply with the emission standards.
5. All vehicles who fail to meet either the muffler requirements or the maximum allowable noise emission limits shall be recorded on Form NPC3-35-1.

CHAPTER 2

TRAINING

Sound Measurement Equipment. Prior to a race event, the person(s) designated to inspect racing vehicles for compliance with the noise control regulations shall become familiar with the sound measurement equipment (this person will be referred to in this procedure manual as the Noise Control Steward or NCS). The Noise Control Steward shall have read the manufacturer's instruction manual for the sound equipment. The NCS also shall have sufficient hands-on experience to feel comfortable operating the equipment.

Noise Control Racing Rules and Procedure Manual. The Noise Control Steward shall have a good working knowledge of the Department of Environmental Quality Noise Control Standards for Motor Sports Vehicles and Facilities (OAR 340-35-040) and its companion document the Sound Measurement Procedure Manual (NPCS-35).

Race Vehicle and Facility. The Noise Control Steward shall have a good working knowledge of the racing vehicles and facility being monitored. This includes:

- a) Knowing the driving characteristics of the race vehicles,
- b) Knowing the layout of the track, and
- c) Knowing the requirements for approved racing muffler systems.

This information will be useful in locating the proper measurement sites and for inspecting vehicles.

CHAPTER 3

MUFFLER SYSTEMS

General. The DEQ regulation requires all types of race vehicles (except Top Fuel Burning Drag vehicles) to be equipped with a "properly installed and well maintained muffling" system. During the vehicle inspection prior to the racing event, the vehicle's muffling system shall be visually inspected by the Noise Control Steward. If the muffling system fails to meet the DEQ muffler requirements, then the vehicle shall not operate at the race facility until the muffling system complies. This chapter describes the procedures for visual inspection of the vehicle's muffling system.

Top Fuel Burning Drag Vehicles. Drag vehicles operating on more than 50% alcohol fuel or on nitromethane are defined as Top Fuel Burning Drag vehicles and are commonly known as Funny cars and Top Fuel cars. Due to the lack of muffler technology needed to quiet this vehicle class, they are not required to have a muffler system under this rule.

"Properly Installed" Mufflers. A properly installed muffling system is:

- a) Correctly installed per manufacturer's instructions,
- b) Fully functional,
- c) Has no leaks or holes in the walls of the exhaust tubing and muffler body, and
- d) Has no defect or modifications to reduce its sound reduction capabilities.

"Well Maintained Muffler" Systems. The DEQ noise regulations specifically state what constitutes a "well maintained muffler" system. If "properly installed" and "well maintained," the following systems meet the requirements of the rule. Note that each and every exhaust outlet must have a muffler located upstream from the outlet.

- 3.4.1 Reverse Flow (Baffle) Mufflers. See Figure 3-1 for examples of reverse flow mufflers. The reverse flow devices incorporate a multitube and baffled design. The exhaust gases do not flow straight through these devices, but take a multipath, back and forth route through the device.
- 3.4.2 Perforated Straight Core with Sound Absorbing Medium. See Figure 3-2 for examples of the perforated straight core with sound absorbing medium mufflers. In order for a straight core device to comply with the requirements, it must meet all the following criteria:
 - a) The central core tube shall be perforated,
 - b) The core shall be fully surrounded from beginning to end with an absorbing medium (e.g., fiberglass, steel wool, etc.).
 - c) The muffler shall not be installed on a rotary engine, and
 - d) The muffler shall meet the following length requirements when used on any drag racing vehicle:

- (i) For any engine exceeding 1600 cc (96.7 cu. in.) displacement, the muffler shall be at least 20 inches (50.8 cm) in inner core length; or
For any non-motorcycle engine equal to or less than 1600 cc (96.7 cu. in.), the muffler shall be at least 12 inches (30.5 cm) in inner core length; or
- (iii) For any four-cycle motorcycle engine, the muffler shall be at least six inches (15.24 cm) in inner core length; or
For any two-cycle motorcycle engine, the muffler shall be at least eight inches (20.32 cm) in inner core length.

Note: The "inner core length" means the length of the main body of the muffler, not including the exhaust tubing leading to and from the main body of the muffler (see Figure 3-2).

- 3.4.3 Annular Swirl Flow (Auger-Type) Mufflers. See Figure 3.3 for an auger type muffler. The exhaust gases in the annular swirl flow muffler follows a circular path down the length of the muffler. The inner design is like an auger. In order for these devices to comply with the noise requirements, they shall meet the following length requirements when used on any drag race vehicles:
 - a) For any engine exceeding 1600 cc (96.7 cu. in.), the muffler swirl chamber shall be at least 16 inches (40.64 cm) in length; or
 - b) For any engine equal to or less than 1600 cc (96.7 cu. in.), the muffler swirl chamber shall be at least 10 inches (25.4 cm) in length.
- 3.4.4 Stacked 360° Diffuser Disc Mufflers. See Figure 3-4 for an example of a Diffuser Disc muffler. This type of muffler works by causing the exhaust gases to bend 90° and then flow through the stacked 360° diffuser discs.
- 3.4.5 Turbocharger. A turbocharger is an exhaust gas driven supercharger. Turbochargers meet the requirements for a "well maintained muffler" system. However, superchargers mechanically driven by the engine are not defined as a "well maintained muffler" system and thus do not meet DEQ muffler requirements.
- 3.4.6 Go-Kart Mufflers. Go-Karts must be equipped with a muffler as specified by the International Karting Federation. See Figure 3-5 for the specifications on go-kart mufflers.
- 3.4.7 Original Manufacturers Muffler on a Motorcycle. The original muffling equipment installed on a motorcycle and designated for use on the motorcycle by the manufacturer, meets the DEQ muffler requirements. The original motorcycle mufflers are generally of reverse flow, baffle and perforated straight core designs.
- 3.4.8 Underwater Exhausted Outboard Boat Motors. Watercraft with motors whose exhaust exits beneath the water

surface during operation are defined as a "well maintained" muffler and meet the DEQ muffler requirements.

- 3.4.9 Other Approved Muffling Devices. Any other muffling device demonstrated effective and approved by the Motor Sports Advisory Committee and the Department of Environmental Quality will then be designated a "well maintained muffler" system.

Other Not Approved Devices. Other devices not meeting the criteria outlined in Section 3.1 to 3.4.9 for a "properly installed and well maintained muffling" system are illegal and shall not be used on vehicles operating at any Motor Sports Facility; except where specific exemption, exception and/or variances apply.

Form NPC-35-1. Form NPC-35-1 contains a condensed version of the information outlined in this chapter. Also, the form contains space for a description of the muffling system and whether it passed or failed the "properly installed" and "well maintained muffling" system requirements.

Fig. 3 - 1 Reverse Flow, Baffled Mufflers

Typical Baffled Muffler

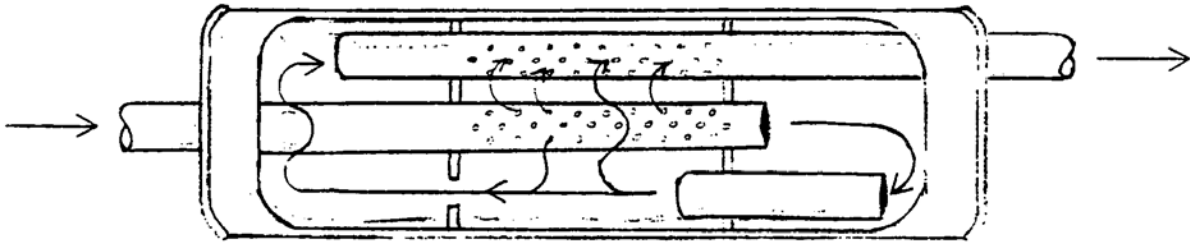

Other Baffled Muffler Designs

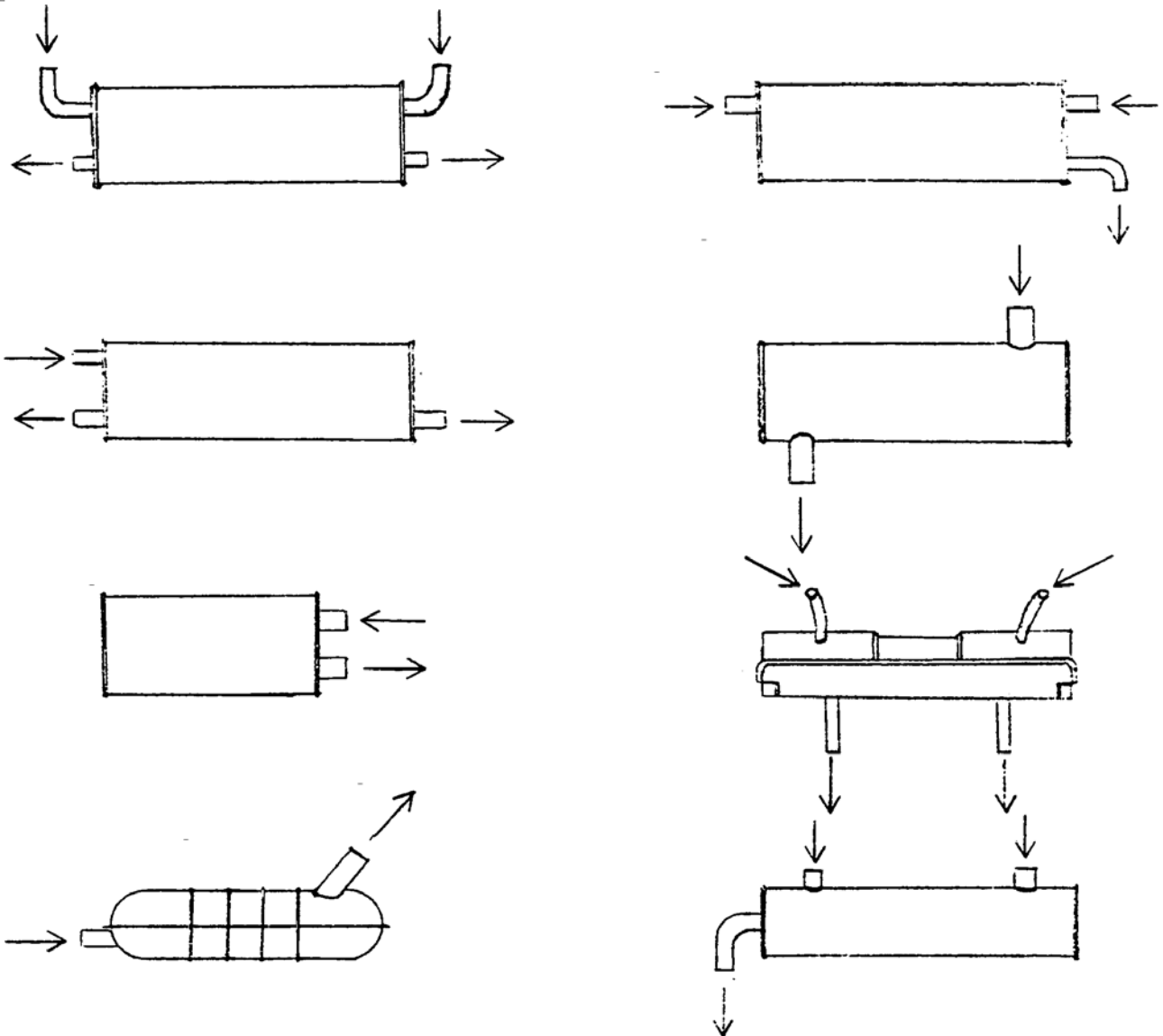
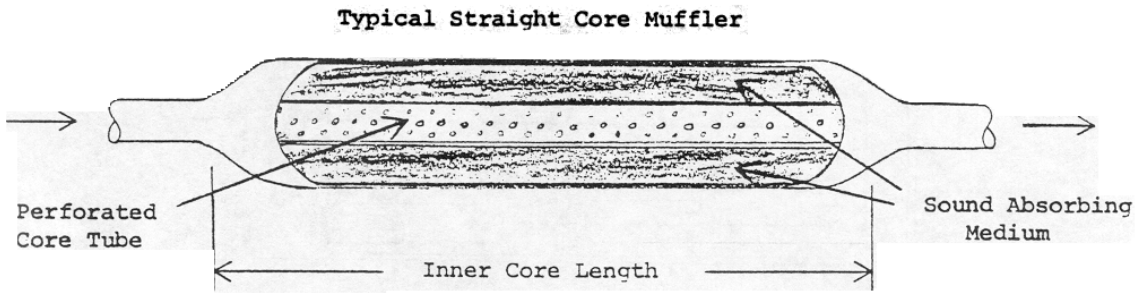

Fig. 3 - 2 Perforated Straight Core Muffler



Another Type of Straight Core Muffler

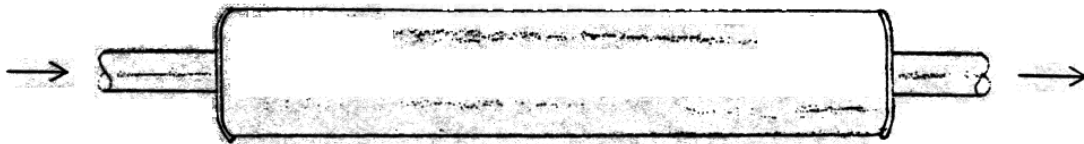

Fig. 3 - 3 Annular Swirl Flow (Auger-Type) Muffler

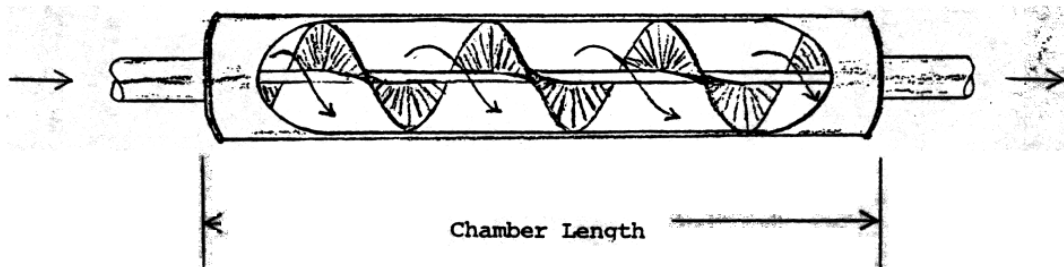

Fig. 3 - 4 Stacked 360° Diffuser Disc Muffler

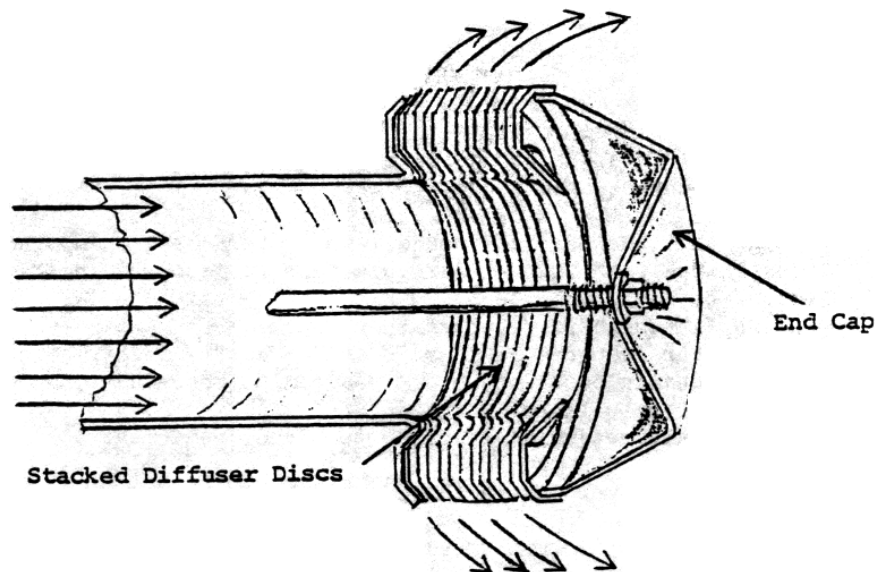
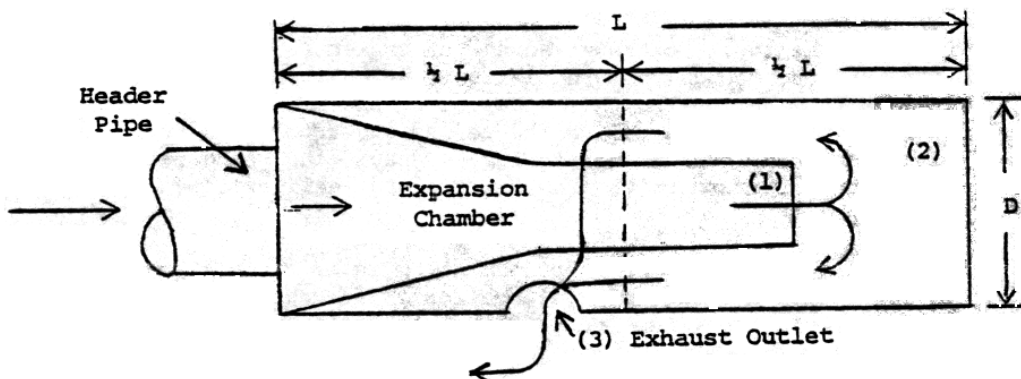

Fig. 3 - 5 Go-Kart Muffler Requirements



All go-kart exhaust systems shall be equipped with a muffler meeting the following specifications:

- a) No minimum or maximum muffler length (L) or diameter (D) is required.
- b) The expansion chamber must outlet (1) into the rear half of the muffler (2), that portion farthest from the header pipe.
- c) The exhaust gas outlet hole to atmosphere (3) may be of any shape, but shall not exceed .7854 sq. inches or the equivalent of a 1-inch diameter circle. Two 1-inch diameter, or smaller, exhaust outlet holes may be used on a single cylinder, 270 cc open class go-kart engine. This applies only to large displacement single cylinder engines in the 270 cc open class. If more than one outlet hole is used on a 270 cc single cylinder engine, no more than two holes may be used, both must be round, and neither hole may exceed 1-inch diameter.
- d) Multiple exhaust gas outlet holes to atmosphere are preferred.
- e) There may be no physical connection between the expansion chamber outlet (1) and the exhaust gas hole to atmosphere (3).
- f) Adjustable pipes are not legal in sprint racing of go-karts.

CHAPTER 4

INSTRUMENTATION

General. This chapter describes the requirements for the sound measurement equipment and its use.

Sound Level Meter. All sound level meters used in monitoring compliance with the noise regulations at motor racing facilities shall be equipped with:

- a) An "A" weighting electronic network,
- b) A meter response similar to ANSI "Fast" and ANSI "Slow".
(Depending on the type of measurement procedure.)
- c) A battery voltage indicator, and
- d) Adequate measuring range to test race vehicles.

Such sound level meters shall also:

- a) Conform to minimum specifications set forth in American National Standard Institute (ANSI) Standards Number S1.4-1971 for type 2 sound level meters, or
- b) Shall be an Oregon Department of Environmental Quality approved sound level meter for use in measuring racing vehicles for the purpose of this rule.

Sound Level Meter Calibration.

4.3.1 Field Calibration. To assure sound measurement accuracy in the field, DEQ recommends that the measurement equipment include an acoustical calibrator which couples to the microphone. Sound meters should be field calibrated before and after, and every two hours during vehicle monitoring. Consult the sound meter's manufacturer's instruction manual for proper calibration procedures.

4.3.2 Annual Calibration. Every year the sound meter and calibrator should receive a laboratory calibration in accordance with manufacturer's specifications. This calibration should be traceable to the National Bureau of Standards.

4.4 Accessories. The following accessories are valuable in gathering sound measurements:

- a) A microphone wind screen (see Section 4.5)
- b) Motor Racing Record Forms (NPCS-35-1)
- c) Clipboard
- d) Tripod to hold the sound level meter
- e) Spare batteries
- f) Screwdriver for sound meter calibration
- g) A tape measure
- h) Ear protectors
- i) A tachometer for stationary noise testing

Sound Measurement Precautions.

Wind. Wind blowing on the microphone can create additional noise in the sound meter. To minimize wind noise, a windscreen on the microphone is recommended whenever measurements are taken. The windscreen should be furnished with the meter by the manufacturer and made of open cell polyurethane foam. This type of windscreen will protect the microphone from wind, dust, accidental shocks, and moisture, while not affecting the sound measurements. Consult the sound meter instruction manual for more details.

Precipitation. Water can damage microphone diaphragms. Hence, the microphone should be protected from moisture at all times. The wind screen will protect the microphone during all but the heaviest rain showers.

- 4.5.3 Background Sound Levels. Sounds from other vehicles or activities can affect sound level measurements made during race vehicle monitoring. To avoid this, it is recommended that the sound level of the race vehicle being measured rise at least 6 dBA before and fall at least 6 dBA after the maximum sound level occurs.

Equipment Set Up and Use.

- 4.6.1 Calibration. The meter should be periodically field calibrated as outlined in section 4.3.1 and following the manufacturer's instruction manual.
- 4.6.2 Battery Check. The batteries in the sound meter and calibrator are to be checked whenever performing field calibrations.
- 4.6.3 "A"-Weighting. The "A"-weighting electronic network on the meter is to be engaged and used during vehicle testing (i.e., not the "B", "C", "D", or flat networks).
- 4.6.4 "Fast" and "Slow". For the moving vehicle test, the fast meter response network is to be engaged and used during testing. For the stationary vehicle test, the slow meter response is to be engaged and used during testing.
- 4.6.5 Microphone Height. The microphone shall be placed on a tripod if an extension cable is used. If a cable is not used, the sound meter with the microphone attached may be hand held or placed on a tripod. Ideally, the microphone should be positioned $4 \pm 1/2$ feet ($1.2 \pm .15$ meters) above the ground or water for the moving test and at the same height as the exhaust outlet for the stationary test. See Chapter 5 for more details.
- 4.6.6 Microphone Orientation. Care should be taken to correctly orient the microphone to the race vehicle. Some microphones are designed to be pointed directly at the noise source, while others are designed to be pointed perpendicular to the sound so that

the sound grazes the microphone diaphragm. Consult the sound meter instruction manual for the proper microphone orientation.

4.6.7 Personnel Location. Care should be exercised to prevent interference with sound measurements caused by personnel in the measuring area. No person should stand between the race vehicle and the sound meter. The person taking sound measurements should stand back from the microphone as much as possible and to one side of the sound path. This will minimize sound reflections off the body. Consult the manufacturer's instruction manual for more details. Bystanders should stand behind the test personnel to minimize body reflections.

4.6.8 Range Setting. Set the meter to the appropriate range to measure the anticipated sound level.

CHAPTER 5

SOUND MEASUREMENT SITES AND PROCEDURES

- 5.1 General. The DEQ noise regulations for motor sports facilities require all race vehicles , except for drag vehicles, to meet specific maximum allowable sound emission limits. Also the noise regulations specify the type of noise test procedures to be followed. The non-motorcycle race vehicle categories are only noise tested while moving about the race course. Open course motorcycles are tested only while stationary. Closed course motorcycles are tested either while moving or while stationary at the option of the Noise Control Steward.

For the moving vehicles noise test, the vehicle is first inspected to determine if it complies with the muffler requirements (See Chapter 3). If the muffler complies, then the vehicle can be allowed to operate on the facility for practice runs prior to the race event. During these practice runs, the Noise Control Steward shall take sound measurements to determine if the vehicle complies with the noise emission limits. If it fails the emission limits, then the vehicle shall not be allowed to operate further on the facility until the emissions are lowered. Section 5.2 describes the moving vehicle sound measurement procedures.

For the stationary vehicle test, the muffler system is first inspected for compliance with the muffler requirements. If it complies, then the vehicle is stationary noise tested, per the test procedures in Section 5.3. If the vehicle fails the muffler requirements and/or the noise emission limits, it shall not be allowed to operate on the race facility until it complies.

- 5.2 Moving Vehicle Sound Measurement Procedure.

- 5.2.1 Microphone Height. Ideally, the sound measurement area for the moving vehicle test should be flat and the microphone positioned $4 \pm 1/2$ feet ($1.2 \pm .15$ meters) above the plane of the ground or water surface. In practice, this is sometimes difficult to achieve. Figure 5-1 shows some acceptable microphone heights. In general, the NCS should maintain at least 3-1/2 feet of line-of-site clearance between the microphone and the vehicle above the surrounding ground terrain.

- 5.2.2 Blockage of the Sound Path. The ideal moving vehicle measurement site is shown in Figure 5-2. The ideal site is flat and is clear of objects within the area between the vehicle path and the microphone position for a distance of 100 feet (30.5 meters) in each direction along the track. Objects located within the measurement area between the vehicle and the microphone can potentially influence the sound level measurements. Any site where an object "significantly" blocks the sound path is not a legitimate test site and shall not be used for monitoring compliance with the noise standards for racing facilities.

At most moving vehicle test sites, there will be something located within the measurement area that may block sound (i.e., Armco safety barriers, hay bales, fences, bleachers, other race vehicles, trees, piles of dirt, etc.). Fortunately, not everything will "significantly" block the sound path. If the following conditions are met, then a moving vehicle test site is not "significantly" blocked and is therefore an acceptable test site:

- 1) In general, there must be good line-of-sight clearance between the microphone and the vehicle exhaust outlets (excluding shielding by the vehicle body) for most of the vehicle's pass by. More precisely, the line-of-sight view of exhaust outlets must be at least 80% open area during the pass by, and
- 2) The area immediately in front of the microphone must be clear of obstruction.

If the Noise Control Steward has any doubts about the site, then choose an alternate measurement site.

Reflective Surfaces. Objects with large flat surfaces (excluding the ground or water surface) which are basically parallel to the track and located behind the microphone or on the other side of the track, can increase the measured sound level. The ideal moving vehicle measurement site has no reflective surfaces located in an area less than 100 feet (30.5 meters) from the microphone and the microphone point (see Figure 5.2). Since an ideal site with no reflective surfaces is not always available, then the next best thing is to not measure at sites where reflective surfaces are less than the following distances away from the microphone or the race vehicle:

- a) 10 feet (3.0 meters) for the 50 ft. (15.24 m) measurement sites, or
- b) 20 feet (6.0 meters) for the 100 ft. (30.5 m) measurement sites.

50 Ft. Trackside Measurement Point. The DEQ noise regulations for racing facilities specifies a moving vehicle sound measurement position (microphone location) at "trackside." "Trackside" is defined as 50 feet (15.24 meters) from the edge race vehicle. For the purpose of this rule, this means the sound measurements shall be made 50 feet (15.24 meters) from the edge of the Driving Groove. The Driving Groove is the path that most race vehicles follow around the race course. In order to determine the driving groove, the Noise Control Steward must draw upon his knowledge of the race vehicles and the race course.

After the driving groove has been located, the NCS shall measure 50 feet (15.24 meters) from the edge and perpendicular to the driving groove. This is the position where sound measurements will be taken.

Note: It is recommended that a mark be placed at the edge of the driving groove, perpendicular to the microphone. This can be used to determine the location of each vehicle with respect to the 50 foot monitoring distance. (See

Section 5.4.2 for more details)

- 5.2.5 Alternate 100 ft. Trackside Measurement Point. If it is determined that a measurement at 50 ft. (15.24 meters) is unsafe or not feasible, then measurements may be taken at 100 ft. (30.5 meters) for the driving groove. If the 100 foot distance is used a 6 dBA correction shall be added to the observed sound reading or 6 dBA may be subtracted from the required maximum sound emission limits specified in the noise regulations. (The sound emission limits list in form NPC3-35-1 were adjusted.)
- 5.2.6 Choosing Loudest Moving Vehicle Measurement Location. Given the general test site constraints outlined in Section 5.2.1 to 5.2.5, many possible measurement locations are typically available at racing facilities. The moving vehicle standards require race vehicles not exceed a specified noise emission level under all operating conditions (acceleration, deceleration, cruising, full out, etc.). The Noise Control Steward shall therefore monitor for compliance with the moving vehicle limits at those measurement sites where the vehicle is producing its maximum noise levels.

Comment: The Noise Control Steward must measure at the noisiest site. A non-complying vehicle may pass or fail depending on the ability of the steward to choose the noisiest site. The owner of a vehicle that passes or fails due to improper measurement procedures will lose confidence in the validity and the need for the rules. In such a case, the Steward will have compromised the track, sanctioning organization, and the vehicle owner.

Generally, race vehicles produce their maximum noise levels when they are accelerating near the highest engine RPM. Determining the point of maximum sound emissions takes a knowledge of the vehicle and the race course. Even then, vehicles may need to be tested at several sites before a final test site is selected. Long, straight sections of the track tend to be noisier than the corners. Also, vehicles may be noisier on one side than the other, depending on the location of the exhaust outlet. Measurements shall be made on the noisiest side of the vehicle.

- 5.3 Stationary Vehicle Sound Measurement Procedure.
- 5.3.1 Test site. The test site should be relatively flat and free of loose or powdered snow, plowed soil, grass of height greater than 6 inches (.15 meters), brush, trees, or other extraneous material. Also the site should be free of large sound reflective surfaces (other than the ground) such as parked vehicles, sign boards, buildings, or hillsides; located within 15 ft. (4.6 meters) radius of the vehicle being tested.

- 5.3.2 Microphone Location. The microphone shall be located with respect to the rear most exhaust outlet on either side of the vehicle as follows:
- a) 20 inches \pm 1/2 in. (0.5 meters \pm .01 m) from the exhaust outlet,
 - b) At a 45-degree angle (\pm 10 degree), from the axis of the outlet,
 - c) At the same height as the exhaust outlet, and
 - d) With its longitudinal axis parallel to the ground.

Figure 5-3 shows the microphone location.

Note: For microphones designed for grazing noise measurement (see Section 4.6.6), point the microphone rearward away from the engine. Further no wire or other means of distance measurement shall be attached to the microphone. This may lead to erroneous readings.

- 5.3.3 Vehicle Operations. The rider shall sit astride of the motorcycle in a normal riding position with both feet on the ground. The engine shall be operated at the normal operating temperatures with gear box in neutral. If no neutral is provided the motorcycle shall be operated either with the rear wheel clear of the ground, or with the drive chain or belt removed. The sound level measurement shall be made with the engine speed stabilized at one of the following values. (The preferred test procedure is listed first; the least preferred test procedure is last):

- a) The engine speed shall be stabilized at 50% (1/2) of the manufacturer's recommend maximum engine speed ("Red Line RPM"), or
- b) If no "Red Line RPM" is published for the vehicle, then stabilize the engine speed at 60% of the engine speed at which maximum horsepower is developed, or
- c) If neither "Red Line RPM" nor maximum horsepower RPM information is available, then calculate the test RPM from the following formulae:

$$\text{RPM} = \frac{306,000}{\text{stroke in mm}} \quad \text{or} \quad \text{RPM} = \frac{12,000}{\text{stroke in inches}}$$

- d) If engine test speed cannot be determined from steps a, b, and c above or if a tachometer is not available, then test the motorcycle at 1/2 of full open throttle.

Comment: During stationary noise testing, the Noise Control Steward should make certain the tachometer is accurately measuring the engine speed. Also do not allow the exhaust to impinge on the microphone.

5.4 Sound Measurements

- 5.4.1 Preliminary Steps. The following steps should be followed before taking sound measurements.
- a) Check battery
 - b) Calibrate sound meter
 - c) Switch meter to "A" weighting scale.
 - d) Set meter to correct a range setting
 - e) Windscreen - on
 - f) No significant blockage of the sound path
 - g) No reflective surfaces
 - h) Test personnel located correctly behind meter
 - i) No significant background noises.
 - j) For moving vehicle sound testing:
 - * Select the loudest measurement site
 - * Determine the Driving Groove
 - * Place the meter at 50 (or 100 ft.) from Driving Groove
 - * Set meter on "Fast" response
 - * Set meter at $4 \pm 1/2$ ft. above terrain
 - * Point microphone correctly
 - * Monitor the loudest side of vehicle
 - k) For stationary vehicle sound testing:
 - * Vehicle at normal temperature and in neutral.
 - * Vehicle operator in normal riding position.
 - * Attach and check tachometer.
 - * Determine the engine test speed.
 - * Monitor the rear most exhaust outlet for each side.
 - * Set the meter to "slow" response
 - * Place microphone 20 inches from exhaust outlet.
 - * Place microphone 45° from the axis of the outlet.
 - * Place microphone at the same height as the outlet.
 - * Place longitudinal axis of the microphone parallel to the ground.
 - * Point the microphone correctly.
 - * Monitor both sides of the vehicle.
 - * Stabilize the engine at the engine test speed.

- 5.4.2 Moving Vehicle Measurements. The measured noise emission level for a moving race vehicle shall be the maximum sound level reading displayed on a meter position 50 or 100 feet (15.2 or 30.5 meters) from the vehicle's driving groove, taken during the vehicle's pass by. To avoid background noise from affecting the sound measurements, the sound level should ideally rise and fall at least 6 dBA from the maximum noise level. Also, the sound meter's "Fast" response should be used.

Ideally, all moving vehicles will follow the driving groove and the sound measurements will be made at the proper measurement distance. However, this may not always be the case. The following comments may be of value to minimize the time it takes for testing vehicles:

- Comment: If the moving vehicle is measured on its noisiest side and under its noisiest operating conditions, then the following statements can be considered valid:
- a) If the vehicle passes less than 50 (or 100) feet from the microphone and does not exceed the noise emission limits, then it does not violate the noise limits at 50 (or 100) feet.
 - b) If the vehicle passes greater than 50 (or 100) feet and exceeds the emission limits, then it does violate the noise limits at 50 (or 100) feet.
 - c) If the vehicle passes less than 50 (or 100) feet and exceeds the emission limits, then the situation is uncertain and the vehicle shall be remeasured.
 - d) If the vehicle passes greater than 50 (or 100) feet and does not exceed the emission limits, then the situation is again uncertain and the vehicle shall be remeasured.

5.4.3 Stationary Vehicle Measurements. The reported noise emission level for the stationary vehicle shall be the highest sound level reading displayed on the meter during steady state operation at the proper engine speed. Sound level readings obtained during acceleration or deceleration of the engine are not included. If there are exhaust outlets on both sides of the vehicle, then readings shall be obtained on both sides and the highest reading reported as the vehicle's emission level. The sound meters "Slow" response should be used for stationary testing. Although the "Fast" response is acceptable. Further, to avoid background noise from affecting the sound measurements, the sound level should ideally rise and fall at least 6 dBA from the maximum noise level.

5.4.4 Recording Sound Level Measurements. Noise data for all race vehicles which exceed the maximum allowable noise emissions shall be recorded on form NPC-35-1. The race facility owner shall keep such recorded noise data for a period of at least one calendar year and, upon request, shall make such data available to the Department. The owner may also submit the data to the Department for storage.

5.5 Form NPC-35-1. Form NPC-35-1 is used to record muffler and sound level data on all race vehicles exceeding the DEQ noise standards. Figure 5-4 shows an example of Form NPC-35-1. Enclosed in this procedure manual is a master form of NPC-35-1 to be photocopied and used to record race data. The following describes form NPC-35-1 and the information to be recorded on it:

- a) The name and location of the racing facility.
- b) The name of the sponsoring organization, if any.
- c) Name of the individual who inspected the vehicles for compliance with the noise standards.
- d) Mark the type of racing event and the appropriate maximum allowable noise emission limits for the event.
- e) Description of the sound level meter (make and model).

- f) Location of the measurement site and distance from race vehicle.
- g) A check list for use in taking sound level measurements is included on the form.
- h) The description of the racing vehicle (type of vehicle, vehicle number, driver's name, etc.).
- i) The maximum measured sound level expressed in dBA (decibels measured on an "A" weighted sound meter). This is at 20 inch, 50 ft., or 100 ft. depending on what type of test was performed as indicated in item d and f above. Also include with the sound level, the test RPM for the 20 inch stationary test.
- j) A list of muffling systems which meet the requirements for a "Well Maintained Muffling System" is included on the form.
- k) Indicate on the form whether the vehicle passed or failed the visual inspection of the muffling system (whether or not the vehicle meets the "properly installed and well maintained muffler" requirements).
- l) Describe the muffler system and given the reason(s) for vehicle passing or failing the visual inspection of the muffling system. (See list of "Well Maintained Muffling Systems" included on the form.)
- m) Indicate any results or actions taken on the vehicle (i.e. not allowed to race, muffler was fixed and retested, etc.).

Note: Form NPCS-35-1 is designed to provide the user with most of the important information contained in the DEQ race noise standards and procedure manual. However, this form could not contain all the information. Consult the standards and the manual if questions arise.

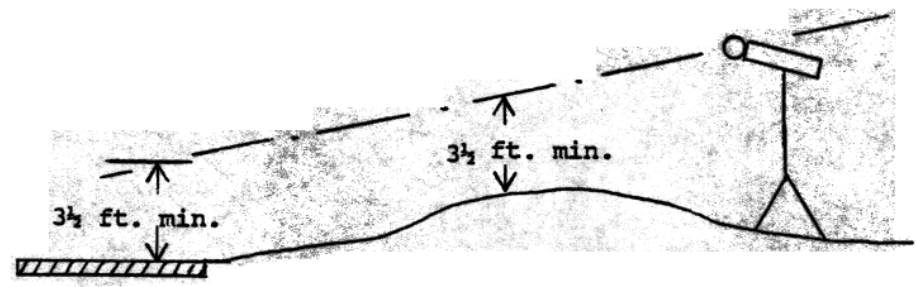
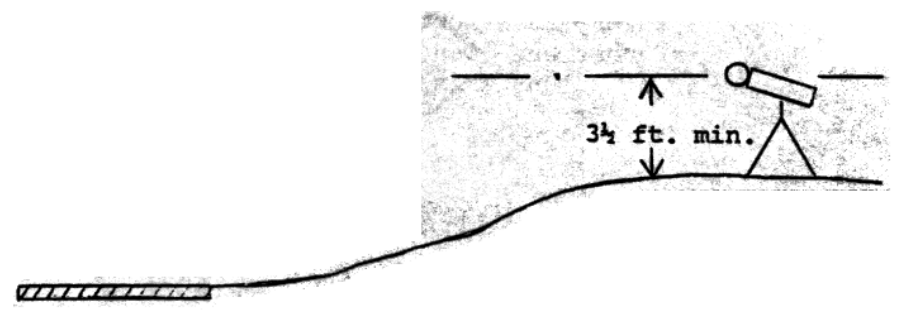
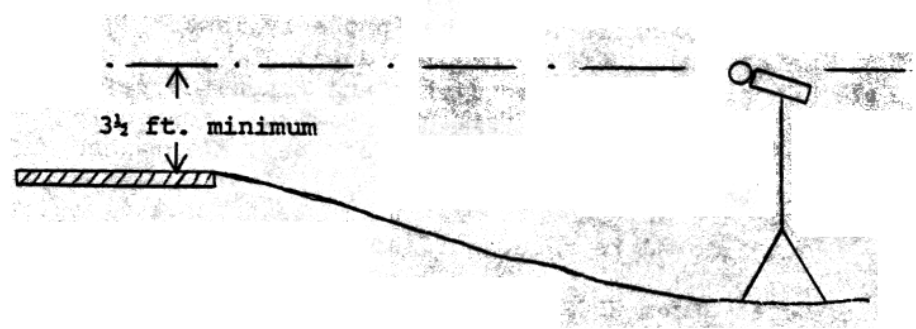
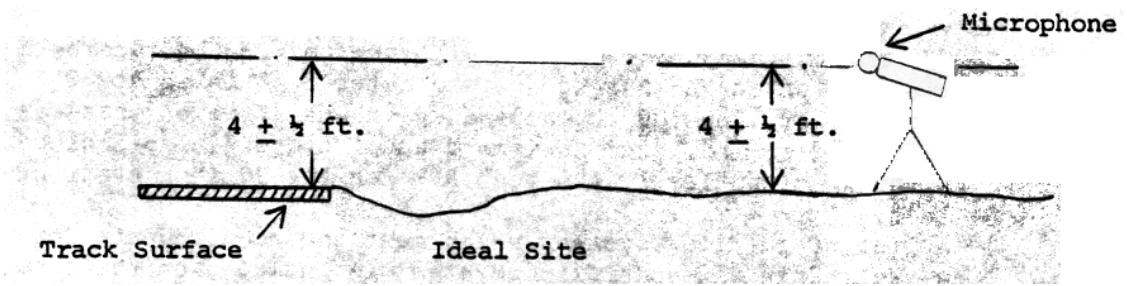

Fig. 5 - 1 Acceptable Microphone Heights

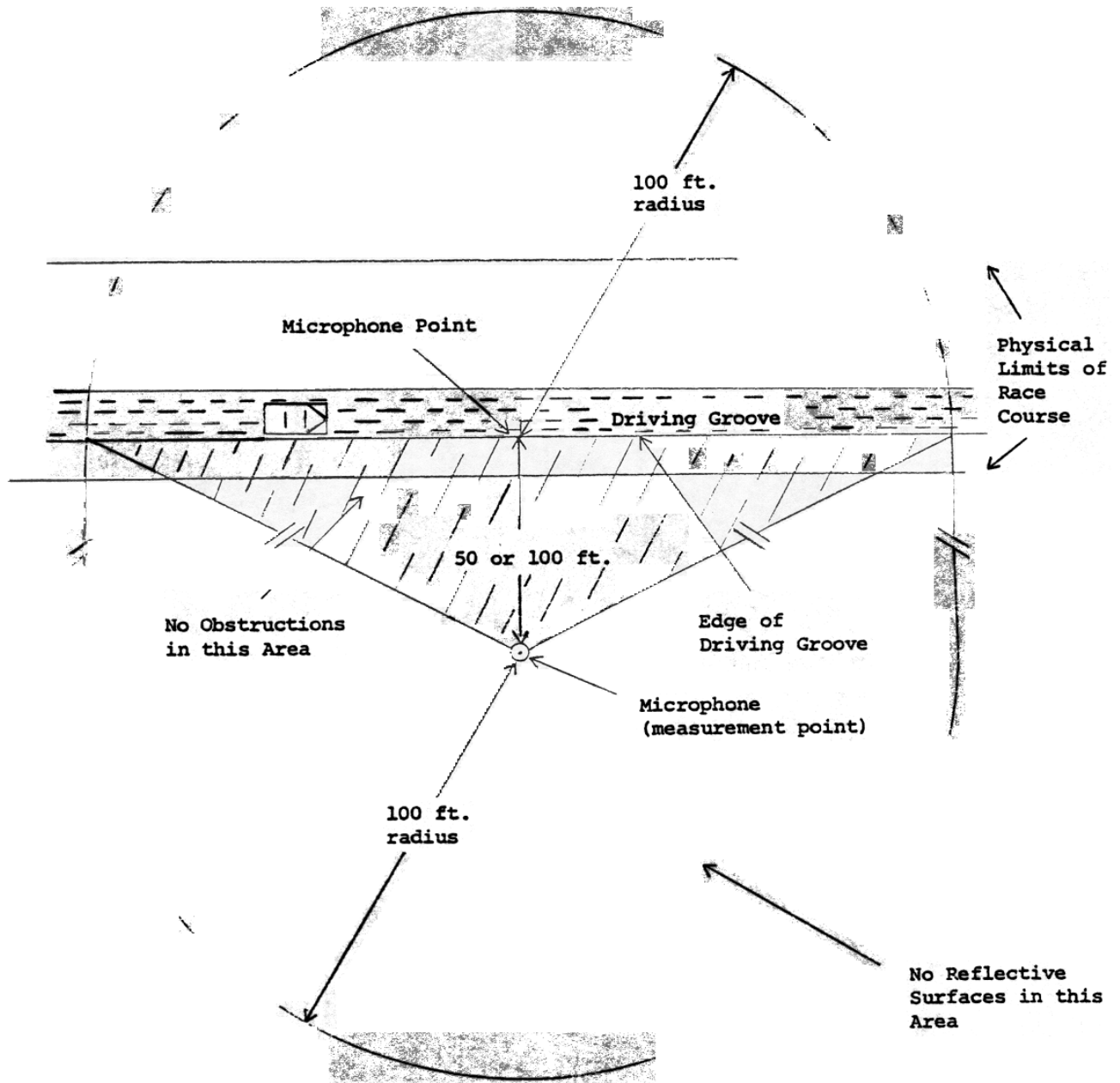
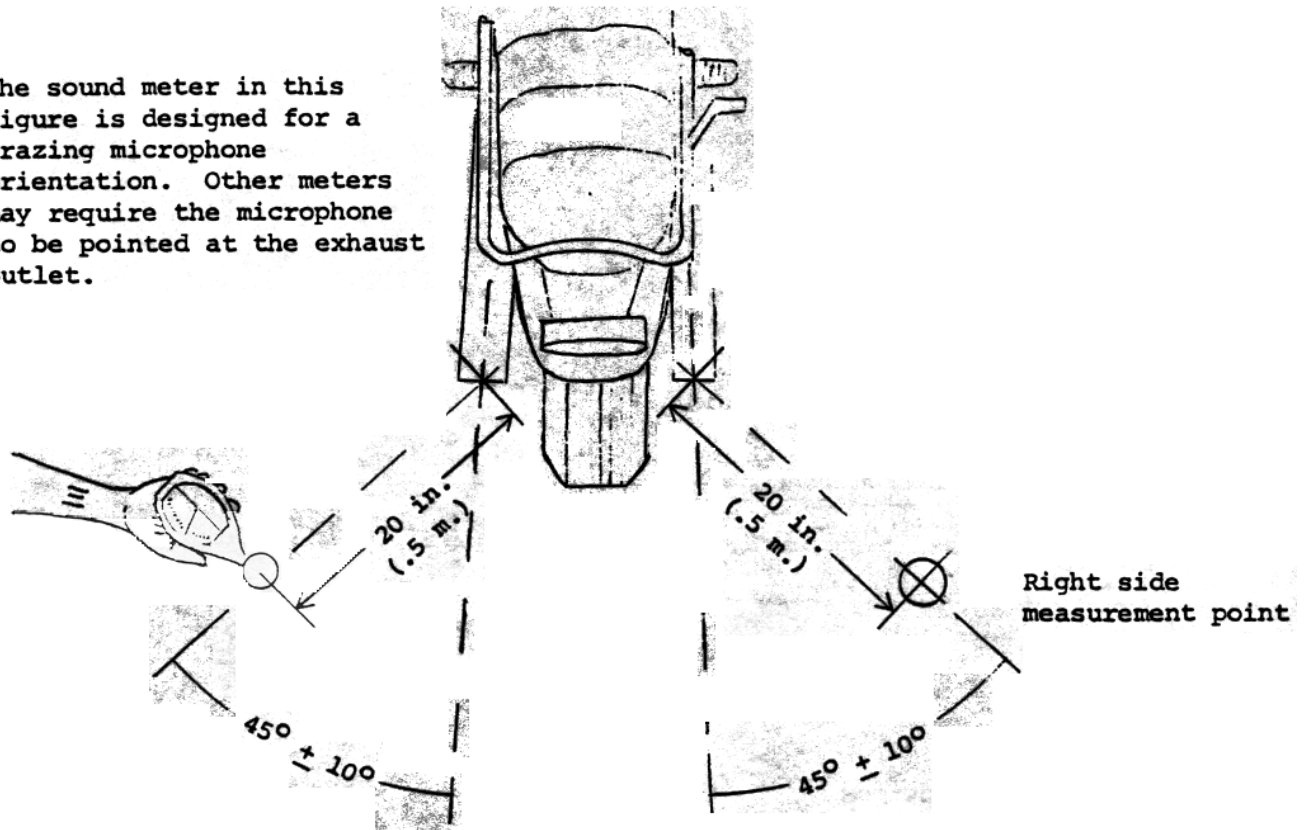

Fig. 5-2 General Layout of Ideal Moving Vehicle Sound Measurement Site (Flat Terrain, No Obstructions to Block the Sound Path, No Reflective Surfaces)

Fig. 5-3 Stationary Test Microphone Location

The sound meter in this figure is designed for a grazing microphone orientation. Other meters may require the microphone to be pointed at the exhaust outlet.



- * Measure from rear most exhaust outlet on each side.
- * For exhaust outlets on both sides, measure both.
- * Report the highest reading at the test RPM.
- * Do not allow exhaust to impinge on the microphone.

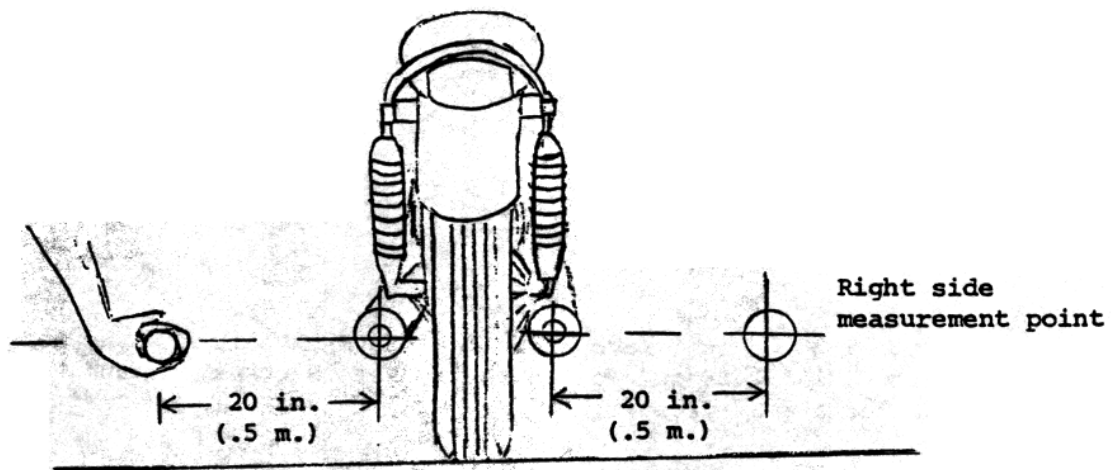

DEPARTMENT ENVIRONMENTAL QUALITY
MOTOR SPORTS RACING RECORD FORM #1

Racing Facility Name and Location: Acme Race Track - Smallville

Sponsoring Organization: 23rd St. Sports Car Club

Mark Type of Race and Max. Allowed Noise Excessions:

<input type="checkbox"/> Drag	105	99
<input type="checkbox"/> Oval	105	99
<input checked="" type="checkbox"/> Sports Car	105	99
<input type="checkbox"/> Closed Course Motorcycle	105	99
<input type="checkbox"/> Open Course Motorcycle	105	99
<input type="checkbox"/> 4-wheel Drive	105	99
<input type="checkbox"/> Water Craft	105	99
<input type="checkbox"/> Autocross	90	84
<input type="checkbox"/> Go-Kart	105	99
<input type="checkbox"/> Other		

Date: Nov. 4 1980 Inspected By: John Doe

Sound Meter Make and Model: Gen Rad 1983

Sound Measurement Positions: North Straight - 50 yds

Sound Measurement (Check List):

- Battery and Meter Calibration - OK
- "1" - Weighing and Windscreen
- "2" - "Feet" - for moving, "Glow" - for stationary
- No Reflections or microphone of Path
- Low Background Noise
- MOVING TEST -
- Wind Loadset 50 ft. and 100 ft. from driving groove
- Microphone height and orientation - OK
- Test Loud side of vehicle
- STATIONARY TEST -
- Microphone at 20 ft. and 40' from outlet
- Test at 50' of mid line or off (see Manual)
- Test both sides at steady state RPM

VEHICLE DESCRIPTION

Smith #19	109
Jones #3	-
Brown #12 (Rotary Engine)	-
Wilson #5 (1700 cc)	111
Roberts #10 (1200 cc)	115
Brown #12 (see above)	97
Mc Kay #2	101

MEASURED NOISE LEVEL (dba & RPM)

VISUAL INSPECTION OF THE MUFFLING SYSTEM

RESULTS AND ACTIONS

Muffler System	Describe Reason(s) for Pass/Fail (see list above)	RESULTS AND ACTIONS
<input checked="" type="checkbox"/> Pass <input type="checkbox"/> Fail	Diffuser Disc Muffler	Took some discs out of muffler; Passed at 102 dba
<input checked="" type="checkbox"/> Pass <input type="checkbox"/> Fail	No Muffler; Straight Pipes	Not allowed on track
<input type="checkbox"/> Pass <input checked="" type="checkbox"/> Fail	Straight core muffler on a Rotary Engine Car	Said he would fix it.
<input checked="" type="checkbox"/> Pass <input type="checkbox"/> Fail	Deaf exhaust, 14-inch glass pipe on each side	Not allowed to race
<input checked="" type="checkbox"/> Pass <input type="checkbox"/> Fail	Stock Mustang Mufflers	Not allowed to race
<input checked="" type="checkbox"/> Pass <input type="checkbox"/> Fail	Stock ballid mufflers	Altho
<input checked="" type="checkbox"/> Pass <input type="checkbox"/> Fail	Stock mufflers	Just inspected and OK if provided.

All non-Top Fuel Burning Drag² vehicles must have "properly installed and well maintained muffling" system. If properly installed, the following systems meet this requirement. Also, all exhaust outlets must be muffled:

1. Reverse Flow, Baffle Muffler
2. Stock Diffuser Disc Muffler
3. Exhaust Turbocharged system
4. Muffler Approved for Go-Karts
5. Original Factory Muffler Installed on a Motorcycle
6. Underseat Exhausted Outboard Boat Motor
7. Auger Type Muffler
 - a. Minimum 16" muffler for greater than 1600 cc engines, or Drag Vehicles Only.
 - b. Minimum 10" muffler for 1600 cc or less engines.
8. Perforated Straight Core, Absorbent Lined Mufflers NOT installed on a Rotary Engine
 - a. Minimum 20" muffler on any engine exceeding 1600 cc,
 - b. Minimum 12" muffler on a non-motorcycle engine 1600 cc or less,
 - c. Minimum 6" muffler on any 1-cylinder motorcycle engine, or
 - d. Minimum 8" muffler on any 2-cylinder motorcycle engine.
9. Any other DEQ approved muffling system.

(1600 cc = 96.7 cu. in.)

(1) Only those race vehicles failing to comply with the "properly installed and well maintained muffler" requirements and/or the maximum allowable noise emission requirements, are required to be recorded on this form.

(2) Top Fuel Burning Drag vehicles are powered by greater than 50% alcohol or by nitromethane and are commonly known as top fuel or funny cars. These vehicles are not required to have a muffler.

(3) An Exhaust Turbocharged system is considered a "well maintained muffling" system.

Fig. 5 - 4

Example of Form
NPCS-35-1

DEPARTMENT OF ENVIRONMENTAL QUALITY
MOTOR SPORTS RACING RECORD FORM 1

Racing Facility Name and Location:

Date: _____ Inspected By: _____
Sound Meter Make and Model: _____

Sponsoring Organization:

Sound Measurement Position: 20 In. 50 Ft. 100 Ft.

Mark Type of Race and Max. Allowed Noise Emissions:

	-dba-	
	20	50
	In.	50
		100
		Ft.
<input type="checkbox"/> Drag	105	99
<input type="checkbox"/> Open Car	105	93
<input type="checkbox"/> Closed Course Motorcycle	105	93
<input type="checkbox"/> Open Course Motorcycle	105	93
<input type="checkbox"/> 4-wheel Drive	105	93
<input type="checkbox"/> Water Craft	105	93
<input type="checkbox"/> Autocross	90	84
<input type="checkbox"/> Co-Start	105	99
<input type="checkbox"/> Other		

Sound Measurement Check Lists:
 Battery and Meter Calibration - OK
 "A" Weighting and Windscreen
 "Fast" - for Moving, "Slow" - for Stationary
 No Reflections or Blockage of Path
 Low Background Noise
 - NOISE TEST -
 Find loudest site and driving groove
 50 or 100 Ft. from driving groove
 Microphone Height and Orientation - OK
 Test Loud Side of Vehicle
 - STATIONARY TEST -
 Microphone at 20 in. and 45° from outlet
 Thermometer Working - OK
 Test at 50% of Red Line or... (see Manual)
 Test Both Sides at Steady State RPM

VEHICLE DESCRIPTION

24

MEASURED NOISE LEVEL (dba & RPM)

Muffler System Pass Fail

Muffler System Pass Fail

Muffler System Pass Fail

Muffler System Pass Fail

Muffler System Pass Fail

Muffler System Pass Fail

Muffler System Pass Fail

Muffler System Pass Fail

RESULTS AND ACTIONS

All non-Top Fuel Burning Drag² vehicles must have a "Properly Installed and Well Maintained Muffling" system. If properly installed, the following systems meet this requirement. Also, all exhaust outlets must be muffled:

- Reverse Flow, Baffle Muffler
 - Stacked Diffuser Disc Muffler
 - Exhaust Turbocharged System
 - Muffler Approved for Co-Starts
 - Original Factory Muffler Installed on a Motorcycle
 - Underseater Exhausted Outboard Boat Motor
 - Auger Type Muffler
 - Minimum 16" muffler for greater than 1600 cc engines, or Drag Vehicles Only
 - Minimum 10" muffler for 1600 cc or less engines.
 - Perforated straight Core, Absorbent Lined Mufflers; Not installed on a Rotary Engine
 - Minimum 20" muffler on any engine exceeding 1600 cc,
 - Minimum 17" muffler on a non-motorcycle engine 1600 cc or less, } Drag Vehicles
 - Minimum 6" muffler on any 4-cycle motorcycle engine, or } Only
 - Minimum 6" muffler on any 2-cycle motorcycle engine.
 - Any other DQD approved muffling system.
- (1600 cc = 96.7 cu. in)

(1) Only those race vehicles falling to comply with the "properly installed and well maintained muffler" requirements and/or the maximum allowable noise emission requirements, are required to be recorded on this form.

(2) Top Fuel Burning Drag vehicles are powered by greater than 50% alcohol or by nitromethane and are commonly known as funny cars. These vehicles are not required to have a muffler.

(3) Considered a "well maintained muffler" system

CHAPTER 6

NOISE IMPACT BOUNDARIES

- 6.1 General. Prior to the construction or operation of any permanent new motor sports facility, the owner shall submit for Department approval the projected daily Noise Impact Boundaries for the facility representing an estimate of maximum projected use. The data and analysis used for determining the boundary shall also be submitted for Department evaluation. The Noise Impact Boundary is a map of the area around the facility with the maximum daily operation Ldn - 55 dBA noise contour drawn on it. The information needed by the Department to evaluate the project are such things as:
- a) Maps giving the physical layout of the facility; the terrain of the land around the facility; the location and type of noise sensitive property nearby; and the local land use zoning.
 - b) Data about the type of events and vehicles using the facility including the days and hours of operation.
 - c) Information about practice sessions.
 - d) Information about recreation use at the facility.
 - e) Information on how the impact contours were predicted.
 - f) Information on the facility's public address system.

The facility owner should coordinate the development of the Noise Impact Boundaries for new facilities with the DEQ Noise Control Section.

NPCS35