

ORDINANCE NO. 843

AN ORDINANCE VACATING A SEGMENT OF SE SANDY AVENUE RIGHT-OF-WAY.

THE TROUTDALE CITY COUNCIL FINDS AS FOLLOWS:

1. Certain portions of rights-of-way historically designated for SE Sandy Avenue have never been developed for infrastructure or other public improvements.
2. Between SE 4th Street and SE 5th Street, Sandy Avenue in its present state is located to the east of the segment in question on a separate, dedicated right-of-way which contains public improvements including roadway and utilities.
3. The City nor any other known stakeholder is currently utilizing this right-of-way segment and has no future intentions to utilize them for future improvements.
4. Approval of the vacation of this right-of-way segment is subject to two decision criteria as outlined in Chapter 6 of the Troutdale Development Code.
5. The Troutdale Planning Commission held a public hearing and reviewed the application on March 15, 2017 and submitted a formal recommendation of approval, based on findings that determined the decision criteria had been met.
6. The City Council held a public hearing and reviewed the application on May 9, 2017 and has determined that the proposed findings are in order.

NOW, THEREFORE, BE IT ORDAINED BY THE COUNCIL OF THE CITY OF TROUTDALE

- Section 1. The findings of fact contained in the Planning Commission's recommendation pertaining to this vacation are hereby adopted and incorporated by reference.
- Section 2. The unimproved right-of-way for SE Sandy Avenue between SE 4th Street and SE 5th Street, as described in Attachment A and shown on the map of Attachment B, be vacated and said tract be conveyed by deed to the owners of adjoining lots. The owners of adjoining lots shall be responsible for paying all associated recording fees.
- Section 3. The Conditions of Approval contained in the Planning Commission recommendation pertaining to this vacation are incorporated by reference.

YEAS: 7
NAYS: 0
ABSTAINED: 0

Casey E Ryan
Casey Ryan, Mayor
5/24/2017
Date

Sarah Skroch
Sarah Skroch, City Recorder
Adopted: May 23, 2017



EXHIBIT "A"

FEBRUARY 21, 2017
ACCOUNT NO.: 17.019VAC

LEGAL DESCRIPTION FOR MR. JAY ELLIS
(STREET VACATION – PORTION OF SE SANDY AVENUE)

A PORTION OF SE SANDY AVENUE (VARIABLE WIDTH) AS DEDICATED ON THE DULY RECORDED PLAT OF "FIRST ADDITION TO TROUTDALE," MULTNOMAH COUNTY PLAT RECORDS, SITUATED IN THE SOUTHWEST ONE-QUARTER OF SECTION 25, TOWNSHIP 1 NORTH, RANGE 3 EAST OF THE WILLAMETTE MERIDIAN, IN THE CITY OF TROUTDALE, COUNTY OF MULTNOMAH AND STATE OF OREGON, BEING MORE PARTICULARLY DESCRIBED AS FOLLOWS:

BEGINNING AT THE NORTHEAST CORNER OF BLOCK 13, "FIRST ADDITION TO TROUTDALE"; THENCE S.00° 19'55"W., ALONG THE EAST LINE THEREOF, A DISTANCE OF 200.00 FEET TO THE SOUTHEAST CORNER OF SAID BLOCK 13; THENCE S.72° 14'50"E., A DISTANCE OF 31.44 FEET TO A POINT IN THE EASTERLY RIGHT-OF-WAY LINE OF SE SANDY AVENUE (30 FEET IN WIDTH); THENCE N.00° 19'55"E., ALONG SAID EAST RIGHT-OF-WAY LINE, A DISTANCE OF 142.65 FEET TO A POINT IN THE WEST RIGHT-OF-WAY LINE OF SE SANDY AVENUE (60 FEET IN WIDTH); THENCE N.06° 10'40"W., ALONG THE NORTHERLY EXTENSION OF SAID WEST RIGHT-OF-WAY LINE, A

DISTANCE OF 67.19 FEET TO A POINT IN THE EASTERLY EXTENSION OF THE NORTH LINE OF SAID BLOCK 13; THENCE N.89° 40'05"W., ALONG SAID EASTERLY EXTENSION, A DISTANCE OF 22.38 FEET TO THE POINT OF BEGINNING. CONTAINING AN AREA OF 5,887 SQUARE FEET, MORE OR LESS.



RENEWAL DATE: 12.31.18

Attachment "B" to
Ordinance #843

EXHIBIT MAP
FOR A PROPOSED STREET VACATION
CITY OF TROUTDALE PLANNING DEPARTMENT
CASE FILE NO. P2016-14 SE SANDY AVE-RIGHT-OF-WAY VACATION
SITUATED IN THE S.W. 1/4 SECTION 25, T.1N. R.3E., W.M.
CITY OF TROUTDALE MULTNOMAH COUNTY, OREGON

MARX ASSOCIATES
18615 E. BURNSIDE STREET
PORTLAND, OR 97233
TEL: 503-667-5550
FAX: 503-666-8666
EMAIL: DALE@MARXASSOCS.NET

DATE: FEBRUARY 20, 2017
ACCOUNT NO. 17019
DRAWING NO. 17019LGL

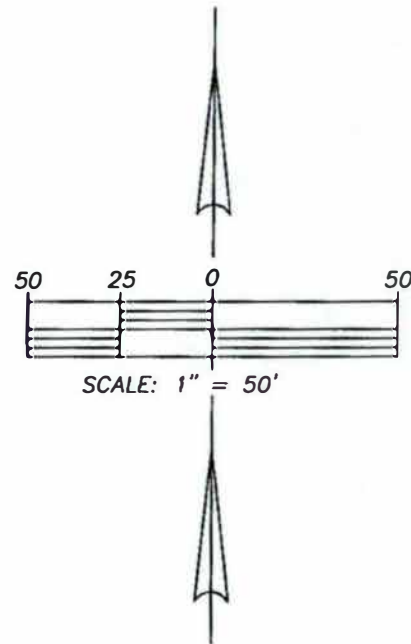
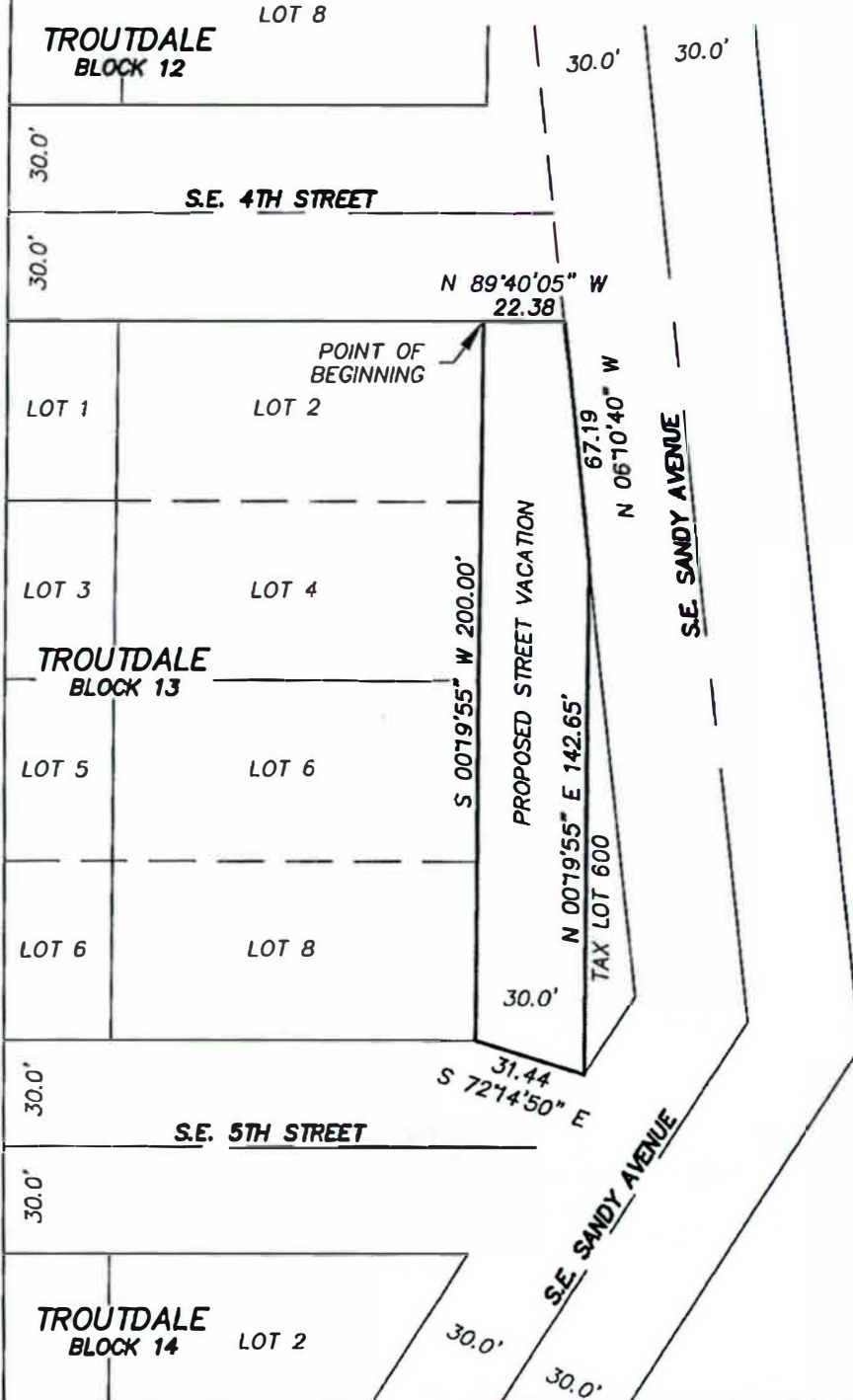

REGISTERED
PROFESSIONAL
LAND SURVEYOR

OREGON
MAY 18, 1986
DALE E. MARX
2196

RENEWAL DATE: 12/31/18